



HAL
open science

THRILLING: AN APPLICATION OF THREAD MILLING PROCESS

Anna Carla Araujo, Jose Luis Silveira

► **To cite this version:**

Anna Carla Araujo, Jose Luis Silveira. THRILLING: AN APPLICATION OF THREAD MILLING PROCESS. IV Congresso Nacional de Engenharia Mecânica, 2006, Recife, Brazil. hal-03212330

HAL Id: hal-03212330

<https://hal.science/hal-03212330>

Submitted on 29 Apr 2021

HAL is a multi-disciplinary open access archive for the deposit and dissemination of scientific research documents, whether they are published or not. The documents may come from teaching and research institutions in France or abroad, or from public or private research centers.

L'archive ouverte pluridisciplinaire **HAL**, est destinée au dépôt et à la diffusion de documents scientifiques de niveau recherche, publiés ou non, émanant des établissements d'enseignement et de recherche français ou étrangers, des laboratoires publics ou privés.



**IV Congresso Nacional de Engenharia Mecânica
22 a 25 de Agosto 2006, Recife-PE**

THRILLING: AN APPLICATION OF THREAD MILLING PROCESS

Anna Carla Araujo

Jose Luis Silveira

anna@ufrj.br

jluis@mecanica.ufrj.br

Programa de Engenharia Mecânica – COPPE / UFRJ

***Abstract.** This paper presents an application of thread milling and drilling models for prediction of forces generated by thrilling tools. The chip thickness and cutting force models are developed considering the unique geometry of the tool. The mechanics of cutting for drilling is applied for the first stage of cut and the thread milling model is applied on a helical path.*

***Keywords:** Thrilling, Thread Milling, Drilling, Mechanistic Model, Force Prediction*

1. INTRODUCTION

The increased use of CNC technology has created the conditions for a future-oriented technology for the production of internal and external threads. Thread milling is a very useful alternative to thread cutting or thread forming in a large number of work cases. It offers some advantages as: high cutting speeds and feeds, multi-functional designs reduce cycle times by combining drilling, chamfering and threading operations into one tool (the same tool for right-hand and left-hand threads), threads with excellent form, finish, and dimensional accuracy, easy machining of difficult materials, Eliminating the possibilities and consequences of tap breakage and reversal of the spindle is not required.

The thrilling tool (Fig. 1) is used for threads in the size range from M4 to 3/4". The tool makes drilling into solid material, chamfering of the thread hole and thread milling in one work process without tool change producing a recess on the bottom of the hole. Mostly used in short-chipping materials.

Mechanistic approach is based on the geometry of the process and relates the forces to the chip load through the specific forces. The specific forces are empirically related to the fundamental machining parameters and the coefficients for a given tool and work piece material combination determined from calibration experiments.

Chandrasekharan (1997) used drilling force signal to determine the coefficients to predict end milling forces. Using the same tool and work piece materials, the specific cutting force is calculated based on the cutting velocities, geometry of cut and the mechanistic coefficients as the mechanistic coefficients are universal for all machining processes.

The thrilling tool is used for both operations: drilling and thread milling. Using the same theory from Chandrasekharan (1997) and as drilling process it is well known, the method confirms the modeling of thread milling operation and also can be used to define the velocities before the machining via drilling measurement and thread milling prediction.



Figure 1. Thrilling Tool

2. PROCESS MOTION

The machining process of thread milling can be divided into seven stages.

1. The first stage involves positioning the tool in the top of the piece.
2. The tool goes down drilling to the depth of the hole on the second stage. (*)
3. The tool comes up for the position of deepest part of the threads.
4. In the same vertical coordinate, the tool goes into the work piece at the prescribed feed rate in a tangential path until reach the final radial depth of cut. In this stage there is also some chip removing. (*)
5. Then, in the fourth stage, the tool is moved up at a given feed rate helically for one complete revolution. The number of threads generated in this one revolution corresponds to the number of threads engaged in the work piece. If generation of the threads for the full depth of the hole is achieved in several steps, the stages 2-3 are repeated until all the threads are generated. (*)
6. Once the threads are generated, the tool moves back to the center of the hole.
7. Finally, the tool is retracted out of the hole.

(*) - Chip removing, machining forces

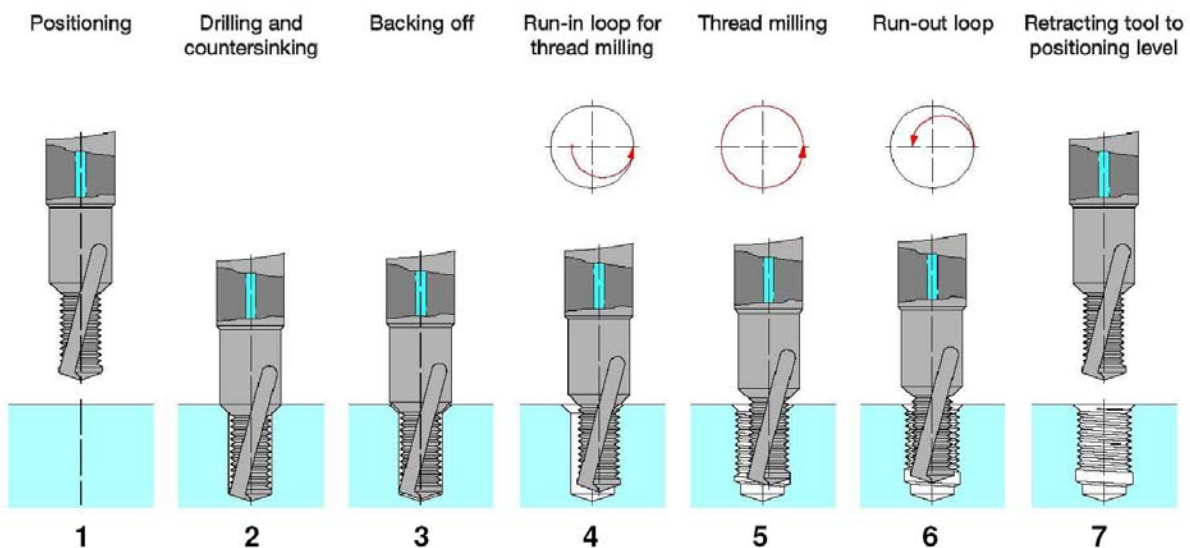

Figure 2. Thrilling Process

As the tool is unique for the process, with the same material and same geometry is important to compare the mechanics of cutting during the different phases comparing parameters found in different operations.

3. TOOL GEOMETRY

The tool geometry is presented in Fig. 3 and 4. Compound of n_f continuous flutes (normally two), each flute has a chisel edge, a drilling cutting edge and a milling cutting edge. The mechanism of thrilling process must be analyzed separately for those three regions.

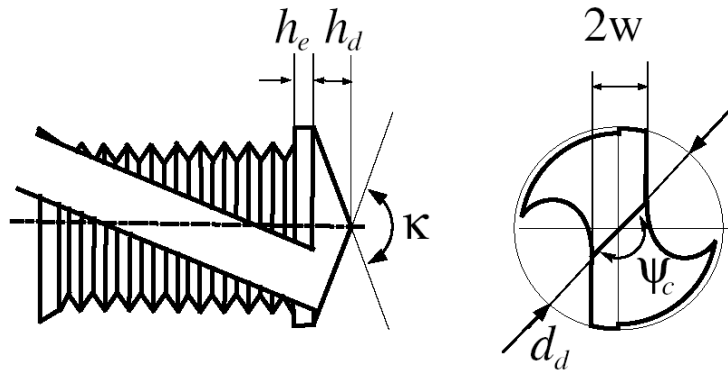

Figure 3. Tool Point Geometry

3.1. Drilling point

The Chisel edge does not cut but only spreads the material sideways by an indentation mechanism. Instead of using the laws of cutting, the mechanism of indentation must be used. It has a width of $2w$ and an edge angle of ψ_c . The drilling cutting edge goes from the external diameter of the chisel edge until the diameter d_d . In the tool front view (Fig. 3) the point angle that locates the chisel edge and the cutting lips is κ . The vertical distance from the bottom of the tool and the end of the drilling cutting edge is h_d . Between the cutting lips and the thread cutting edge there is a vertical edge that separate the drilling part from the thread milling part. This edge will cut as an end milling tool. Its height is h_e

3.2. Thread milling tool part

The upper part of the milling cutting edge is a flute that makes the desired thread form (Fig.4). The thread geometry is characterized by the thread angle ξ and thread pitch p . The helix angle is λ and the rake angle for the thread milling cutting edge is α_h . The maximum diameter of the tool thread is denoted as d_e and the minimum as d_i . Both parts cut together and the programmer should be careful not to machine the previous thread surface when making more then one pitch.

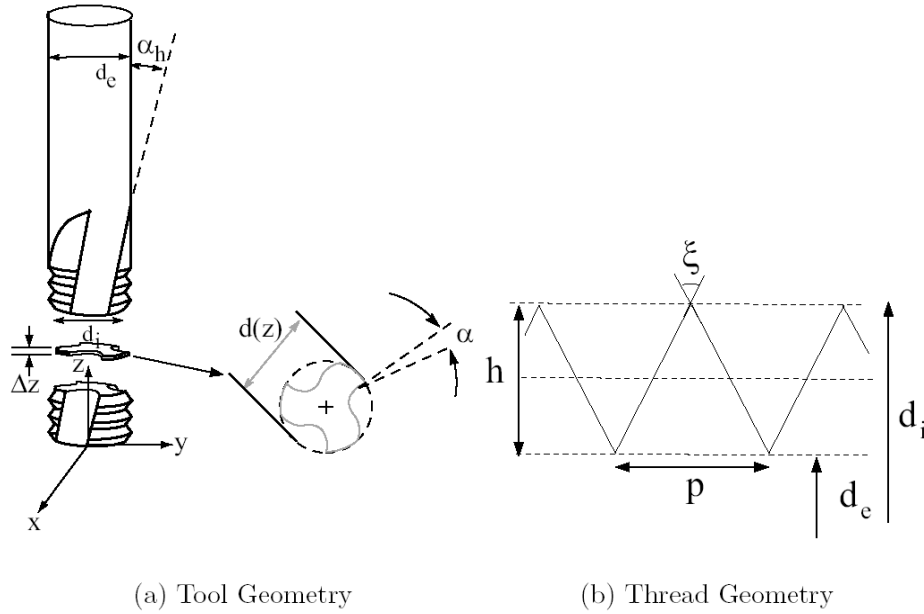

Figure 4. Thread Milling Part

The thread milling part can be analyzed as a stack of disks. Each disk has Δz thickness and a variable diameter $d(z)$ as shown in Fig.4. The variable diameter $d(z)$ can be written as a function of the disk height z measured from the bottom of the tool.

$$d(z) = \begin{cases} d_i + \frac{2(z-h_c-nt(z-h_c)\frac{p}{2})}{\tan(\frac{\xi}{2})}, & \text{if } nt(z-h_c) \text{ is odd;} \\ d_e - \frac{2(z-h_c-nt(z-h_c)\frac{p}{2})}{\tan(\frac{\xi}{2})}, & \text{if } nt(z-h_c) \text{ is even;} \end{cases} \quad (1)$$

$$nt(z) = \text{IntegerPart} \left(\frac{2z}{p} \right) \quad (2)$$

The variation in the disk diameter along the tool causes radial depth of cut to vary for each disk. The angle between the flutes depends on the numbers of flutes N_f and is defined by the tool geometry as

$$\theta_p = \frac{2\pi}{N_f} \quad (3)$$

4. MODEL DEVELOPMENT

A mechanistic oblique-cutting force model is used to develop a three-dimensional force model for the process. The calibration algorithm from Chandrasekharan (1997) is used to extract the oblique butting model coefficients from the drilling stage and it is applied to predict the thread milling forces and prevent from tool breakage and chip welding. This procedure is possible because for the same work piece and tool materials the specific cutting force is the same for any cutting process.

The force signal has a different pattern from the entry of the tool to in the permanent drilling stage and from the end milling part. The interest is to predict the thread milling part based on the

drilling forces. As can be seen in the Figure 5, the first step, when tool is already in the work piece with a pilot hole, is very stable. As the chisel edge it is not acting, the cutting lip is the only part that it is cutting and then the model is very simple to compare with the experimental forces to calculate the specific cutting force.

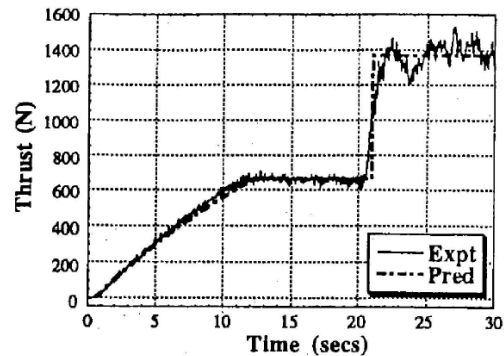

Figure 5. Drilling Force (Chandrasekharan, 1997)

4.1. Extracting Specific Coefficients from Drilling Stage.

The approach used in simulating other processes, in which forces are calculated using the uncut chip area is not completely applied to drilling. Drilling forces are more effectively simulated by dividing the cutting edge into two parts: the part inside an indentation zone, that yield a plastic region of forces produced by the chisel edge due to the material removal by extrusion, and the part that follows the mechanics of cutting.

4.1. Thread milling prediction.

In Araujo (2005), the process has been simplified as a simple linear movement in order to develop and validate the model. In this work, the model is applied in the helical path movement, where the tool goes in x, y and z directions at the same time. Although it is important to consider that the z velocity is very small compared to the cutting velocity and the radius of the curvature of the hole is large compared to the chip thickness. The depth of cut $b(\Omega)$ changes, where Ω is the position of the tool in relation to the center of the hole.

The force calculated by Araujo (2005), F_{tC} , F_{rC} and F_{zC} , are described in the tool axis referential. In x, y and z directions the forces can be written as:

$$\begin{aligned} F_x &= F_{tc} \cos \Omega + F_{rc} \sin \Omega \\ F_y &= F_{rc} \cos \Omega - F_{tc} \sin \Omega \\ F_z &= F_{zc} \end{aligned}$$

(4)

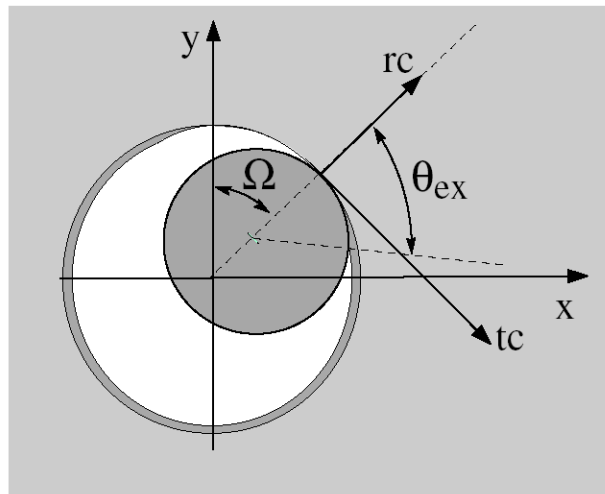

Figure 6. Tool Trajectory

4.2. Chip Modeling.

Trusty concept of the contact interface between the tool and the work piece is used (Araujo, 2003). It is considered two different types of cutting *Type I* and *Type II*. *Type III* (Yang et al, 2005) for low axial and high radial depth of cuts it is not used as in thread milling the associated radial depth of cut is small compared to the tool diameter. In the thread milling geometry e is the radial depth of cut and $b(\Omega)$ is the axial depth of cut. The difference between the initial and final axial depth of cut is normally one pitch.

$$b(2\pi) - b(0) = p \quad (5)$$

The action of one flute is projected in a plane and this plane is unfolded (unrolled). The cutting edge is then a thready line inclined by α_h and it moves from left to right. The entire cutting action can be divided in three phases depending on the length of the cutting edge in contact with the work piece. The limits of each phase are indicated by ψ_n , where the subscript n goes from 1 to 4 depending on the phase. For Type I cutting, the length of the cutting edge increases from 0 to the maximum depth b in phase A, and the rotational angle μ goes from the entry angle, θ_{en} (ψ_1), to δ (ψ_2), which is defined as

$$\delta = \frac{2b(\Omega) \tan \alpha_h}{d_e} \quad (6)$$

In phase B, the cutting edge length in contact with the work piece remains constant and θ goes from δ to the exit angle θ_{ex} (ψ_3). As the tool is going out of the work piece, the cutting edge length gradually decreases (phase C), and the tool is completely out of the work piece when θ is greater than $\psi_4 = \theta_{ex} + \delta$.

The angular position of a point P on the cutting edge is denoted as $\phi(\theta)$ and the points on the cutting edge span from ϕ_i to ϕ_f , which values depend on the phase and the type of cutting. (Araujo, 2005) The total cutting force can be calculated summing the elemental forces on each disk along the tool in contact with the work piece.

For the thread milling process $\theta_{en} = 0$. Because of the thread, the diameter of the cutting edge varies as given in Eq. 1. This variation in the diameter causes changes in the radial depth of cut and consequently the exit angle, which can be written as

$$\theta_{ex} = \cos^{-1} \left(1 - 2 \frac{d(z) - d_i}{d(z)} \right), \quad (7)$$

where $r_o = (d_E - d_c)/2$.

In the presence of run out, each flute rotates at a different radius of rotation R_c . The runout is characterized by the parameters parallel axis offset run out ρ and its locating angle λ . ρ is the distance from the spindle axis to the tool axis and λ is the angle between an arbitrary flute and the direction of the run out. Since each disk element has different diameter, R_c for the cutting edge of n^{th} flute and i^{th} disk element is given as

$$R_c(n) = \sqrt{\rho^2 + \frac{d(z)^2}{4} + \rho d(z) \cos(\lambda + (n-1)\theta_p)}. \quad (8)$$

The chip thickness at time t can be written as:

$$t_c(i, n; t) = \min[m f_t \sin \theta_n(i, n; t) + R_c(n) - R_c(j - m)] \quad \text{for } m = 1..N_f, \quad (9)$$

where f_t is the feed per tooth and the rotation angle of the cutting edge can be written as:

$$\theta_n(i, n; t) = \theta(t) - (n-1)\theta_p - \frac{2z(i) \tan \alpha_n}{d_e}. \quad (10)$$

4.3. Forces and Specific Pressure.

The mechanistic modeling approach is taken for the cutting force model similar to that given in Kline and DeVor (1983). The elemental forces on each disk are expressed as (Araujo, 2005)

$$\begin{aligned} f_{tc}(i, n; t) &= K_t t_c(i, n; t) \cos \theta_n(i, n; t) \Delta z + K_r t_c(i, n; t) \sin \theta_n(i, n; t) \Delta z \\ f_{rc}(i, n; t) &= -K_t t_c(i, n; t) \sin \theta_n(i, n; t) \Delta z + K_r t_c(i, n; t) \cos \theta_n(i, n; t) \Delta z \\ f_{zc}(i, n; t) &= K_z t_c(i, n; t) \Delta z \end{aligned} \quad (11)$$

where K_t , K_r and K_z are the specific cutting energies in the tangential, radial and axial directions, respectively, calculated as a function of the spindle speed, feed rate and the tool-piece material coefficients a_0 , a_1 , a_2 , b_0 , b_1 and b_2 .

$$\begin{aligned} \ln(K_t) &= a_0 + a_1 \ln(f_t) + a_2 \ln(\omega) \\ \ln(K_r) &= b_0 + b_1 \ln(f_t) + b_2 \ln(\omega) \\ \ln(K_z) &= c_0 + c_1 \ln(f_t) + c_2 \ln(\omega). \end{aligned} \quad (12)$$

These directions are located on the cutting edge. The tool referential is located on the tool-piece contact moving with Ω in relation.

$$\begin{aligned}
 F_{tc}(t) &= \sum_{i=1}^{N_z} \sum_{n=1}^{N_f} f_{tc}(i, n; t) \\
 F_{rc}(t) &= \sum_{i=1}^{N_z} \sum_{n=1}^{N_f} f_{rc}(i, n; t) \\
 F_{zc}(t) &= \sum_{i=1}^{N_z} \sum_{n=1}^{N_f} f_{zc}(i, n; t).
 \end{aligned}
 \tag{13}$$

5. RESULTS

The results shown in Figures 7, 8 and 9 were calculated for an Aluminum work piece using the coefficients taken from previous experiments from Araujo (2006). Although, the experimental coefficients should be taken from the drilling stage to be applied into the thread milling stage. In the future work, experiments will be run to validate the procedure.

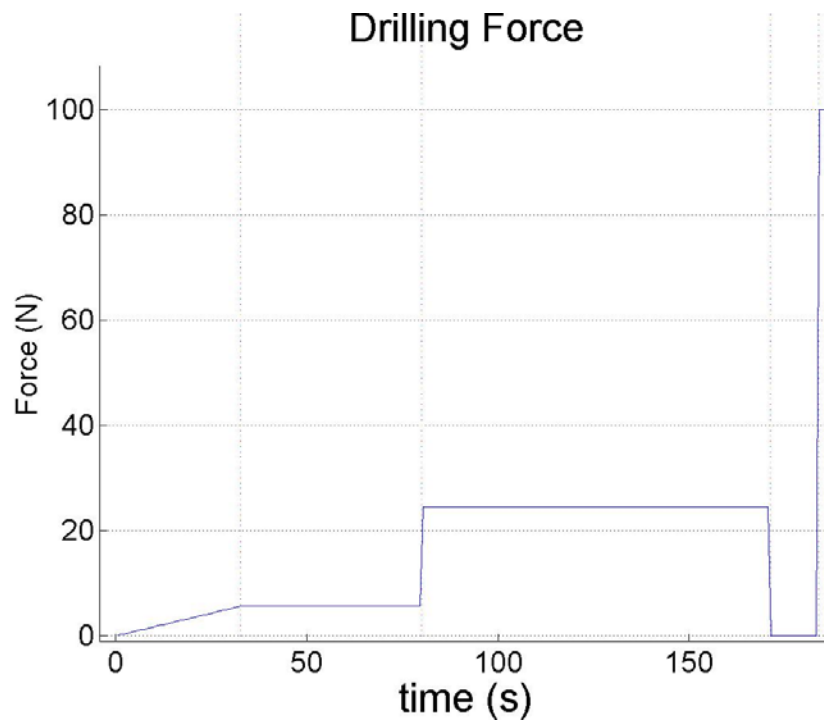

Figure 7. Drilling Force.

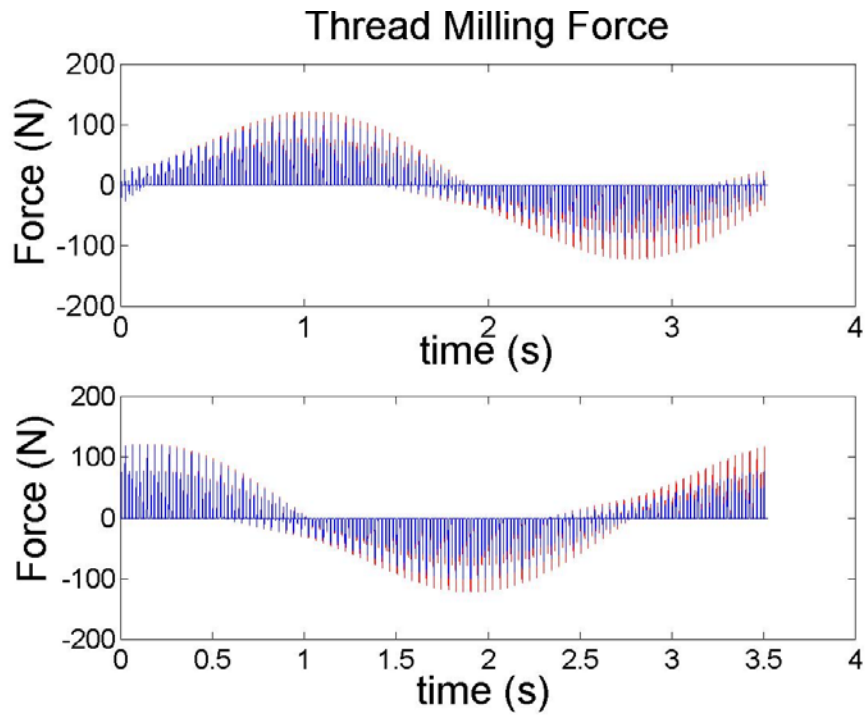

Figure 8. Thread milling force

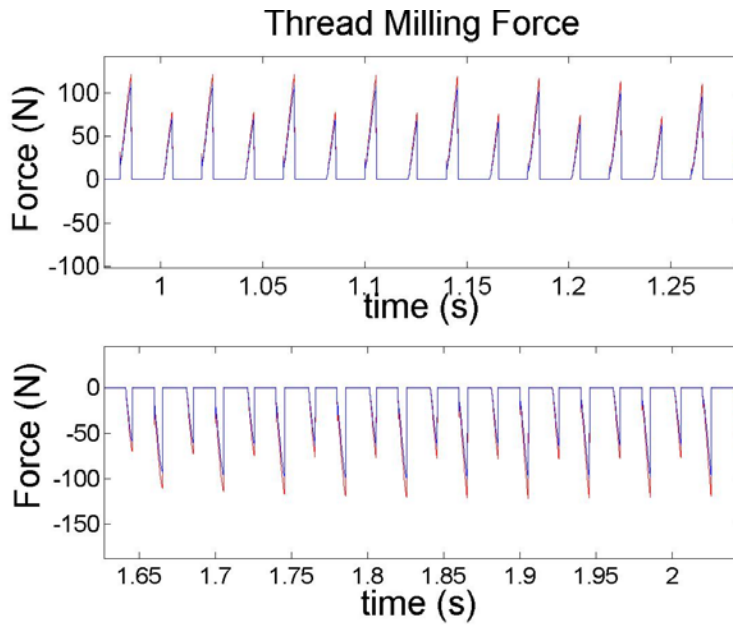

Figure 9. Thread milling force – 10 revolutions

6. CONCLUSIONS

The model for thrilling operations was developed based on the thread milling and drilling model. As the thread milling velocities secure range are not well known, the specific pressures taken from the drilling stage can be used to predict forces on the thread milling stage.

7. ACKNOWLEDGEMENTS

The lead author would like to gratefully acknowledge the fellowship received from CAPES, a Brazilian council for scientific and technological development. All of the authors are grateful for the council and the University of Illinois at Urbana-Champaign in the name of Professor Shiv Kapoor for the support and directions provided during the course of this research.

8. REFERENCES

- A. C. Araujo, J. L. Silveira, M.B.G. Jun, S.G. Kapoor, and R. DeVor, 2006,. "A model for thread milling cutting forces". *Journal of Manufacturing Science and Engineering*, *in press*, 2006.
- A. C. Araujo, J. L. Silveira, and S. G. Kapoor, 2004, "Force prediction in thread milling". *Journal of the Brazillian Society of Mechanical Science and Engineering*, Vol. 26 pp. 82-88.
- Chandrasekharan, S. G. Kapoor, and R. E. DeVor, 1998, "A mechanistic model to predict the cutting force system for arbitrary drill point geometry". *Journal of Manufacturing Science and Engineering*, Vol. 120, pp. 563 - 570.
- Chandrasekharan, S. G. Kapoor, and R. E. DeVor, 1997, "A calibration procedure for fundamental oblique-cutting model coefficients based on a three-dimensional mechanistic drilling force model", *Transactions of NAMRI/SME*, XXV, pp. 255-260.
- Emuge Co. Technical documentation. 2005.
- J. Tlusty and P. MacNeil, 1975, "Dynamics of cutting forces in end milling". *Annals of the CIRP*, Vol. 24, pp. 21-25.
- L Yang, R. E. DeVor, and S. G. Kapoor, 2005, "Analysis of force shape characteristics and detection of depth-of-cut variations in end milling". *Journal of Manufacturing Science and Engineering*, *Trans. of ASME*, Vol 127, pp. 454-462.
- W. Kline and R. DeVor, 1983, "The effects of run-out on cutting geometry and forces in end milling". *International Journal of Machine Tool Design and Research*, Vol. 23, pp. 123-140.