



**HAL**  
open science

## Minimizing task reassignments in the design of reconfigurable manufacturing lines with space restrictions

Abdelkrim R. Yelles-Chaouche, Evgeny Gurevsky, Nadjib Brahimi, Alexandre Dolgui

► **To cite this version:**

Abdelkrim R. Yelles-Chaouche, Evgeny Gurevsky, Nadjib Brahimi, Alexandre Dolgui. Minimizing task reassignments in the design of reconfigurable manufacturing lines with space restrictions. 21st IFAC World Congress, Jul 2020, Berlin, Germany. 10.1016/j.ifacol.2020.12.2785 . hal-03202342

**HAL Id: hal-03202342**

**<https://hal.science/hal-03202342v1>**

Submitted on 29 Sep 2021

**HAL** is a multi-disciplinary open access archive for the deposit and dissemination of scientific research documents, whether they are published or not. The documents may come from teaching and research institutions in France or abroad, or from public or private research centers.

L'archive ouverte pluridisciplinaire **HAL**, est destinée au dépôt et à la diffusion de documents scientifiques de niveau recherche, publiés ou non, émanant des établissements d'enseignement et de recherche français ou étrangers, des laboratoires publics ou privés.



Distributed under a Creative Commons Attribution - NonCommercial - NoDerivatives 4.0 International License

# Minimizing task reassignments in the design of reconfigurable manufacturing lines with space restrictions

Abdelkrim R. Yelles-Chaouche<sup>\*,\*\*,\dagger</sup> Evgeny Gurevsky<sup>\*\*\*,\dagger</sup>  
Nadjib Brahimi<sup>\*\*\*\*</sup> Alexandre Dolgui<sup>\*,\dagger</sup>

<sup>\*</sup> *IMT Atlantique, Nantes, France*

<sup>\*\*</sup> *IRT Jules Verne, Bouguenais, France*

<sup>\*\*\*</sup> *Université de Nantes, France*

<sup>\*\*\*\*</sup> *Rennes School of Business, France*

<sup>\dagger</sup> *LS2N, CNRS, Nantes, France*

**Abstract:** This paper deals with the design of a reconfigurable manufacturing line able to produce multiple products belonging to a same family. The aim is to generate for each product an appropriate line configuration subject to a given set of constraints so as to minimize the number of reassigned tasks when switching from one configuration to another. For this purpose, a mixed-integer linear programming (MILP) model is developed and tested on two categories of instances with 20 and 50 tasks respectively using a commercial solver. The obtained results show the efficiency (in terms of CPU and GAP) of the proposed MILP model to handle the first category of instances. However, it finds its limits to tackle the second category of instances.

Copyright © 2020 The Authors. This is an open access article under the CC BY-NC-ND license (<http://creativecommons.org/licenses/by-nc-nd/4.0>)

**Keywords:** Reconfigurable manufacturing systems (RMS), RMS design, multi-product, MILP.

## 1. INTRODUCTION

Today's industries are facing a harsh and very dynamic environment, mainly due to the global competition and to aware and demanding customers (Koren et al., 2016). As a result, manufacturers seek to design more and more responsive manufacturing systems, since existing ones cannot achieve this. Indeed, although dedicated manufacturing lines (DML) provide high production rates, their rigid structure does not allow them to produce more than one product without a serious and costly changes. By contrast, flexible manufacturing systems (FMS) provide a high degree of flexibility permitting for a wide range of product types to be manufactured. This ability is mainly achieved through the use of computer numerically controlled (CNC) machines. However, such machines are expensive and offer a relatively low production rate and reliability.

In 1999, Koren et al. (1999) introduced the concept of reconfigurable manufacturing systems (RMS). Such systems are designed around a family of products, with the ability to evolve in terms of production capacity and functionality so as to adapt quickly to changing market conditions. Comparing to the previously mentioned manufacturing systems, RMS combine the high productivity of DML and the flexibility of FMS. This is generally made possible thanks to reconfigurable machine tools (RMT). These latter are composed of a set of modules that can be added, moved or removed, offering thus a variety of alternative features.

Much attention has been paid to RMS over the last two decades, where several decision making problems have been arisen (see, for example, recent literature reviews

Bortolini et al. (2018) and Brahimi et al. (2019)). Among these problems, the design of RMS remains one of the major concerns. While taking into account reconfigurable aspects of the system and aiming to optimize its performance, such a problem mainly involves different strategic key decisions including, among others, tasks assignment, equipment selection and system layout. However, most of the authors carry out their studies considering usually a particular product family with a given set of machines already existing on the market. In other words, those studies are context-dependent which make them difficult to be generalized over the RMS concept. Thus, in this paper, we tackle a problem, which not only serves to design a multi-product RMS, but also helps decision makers to conceive their proper set of modular machines/workstations so as to achieve the desired objectives as much as possible.

More precisely, we consider a problem, where exactly the same set of tasks has to be executed for all products. This is due to the fact that they belong to the same family. The tasks are subject to precedence constraints, expressed by a directed acyclic graph (in which each task is represented by a node). However, the latter as well as the processing time of a same task may differ from one product to another.

As concerns the studied line, it is composed of a fixed number of linearly ordered workstations, where tasks are sequentially executed by corresponding equipment. Thus, the load of each workstation is computed as the sum of the processing time of the allocated tasks. This sum cannot exceed the so-called *cycle time*, which expresses the production rate. It is also worth to mention that such a line is flow-oriented and without buffers, meaning that all the products in the line move to their next respective

workstation simultaneously. In other words, the cycle time indicates the time between the release of two consecutive end products.

For a given product, we call a set of workstations with corresponding assigned tasks satisfying all the above-mentioned constraints as a *line configuration*. Since the studied line is designed to handle several products, each requires a particular line configuration, which is not necessarily the same. The products are manufactured sequentially, implying that when a new one has to be produced, the line has to be reconfigured in order to switch from its current configuration to another one, which corresponds to this new product. A reconfiguration is done by reassigning the tasks (with their corresponding modular equipment) between the workstations.

The above described context naturally arises an important optimization problem, which consists in minimizing the number of reassignments when switching from one configuration to another. In Fig. 1, an illustrative example of precedence graphs corresponding to three products with 8 tasks is provided. The processing time of each task is indicated over its corresponding node. The cycle time is set to 40. The optimal configurations are shown in Fig. 2. In this solution, switching from the first product's configuration to the second one requires one modification only, which consists of reassigning the task 1 from the workstation 1 to the workstation 2. Whereas shifting from the configuration 2 to the configuration 3 necessitates four reassignments, and finally, five reassignments are needed to move from the configuration 3 to the configuration 1.

The remainder of this paper is structured as follows. In Section 2, a survey of related work is presented. The MILP model of the above described problem as well as its computational results are respectively elaborated and discussed in Sections 3 and 4. Finally, conclusion, discussion and perspectives are addressed in Section 5.

## 2. RELATED WORK

In view of the current market situation, RMS are considered to be the most suitable solution providing a high degree of flexibility around a part family (Koren and Shpitalni, 2010). However, designing such systems tends to be a very challenging issue, which implies solving complex optimization problems in order to achieve the best RMS performances in terms of investments, productivity and reconfigurability.

For example, in Youssef and ElMaraghy (2007), the authors study the problem of RMS configuration selection while considering some aspects such as the arrangement of machines and equipment selection in order to minimize, among other, the capital cost (which generally includes machine purchasing and operating costs). They also determine alternative configurations to anticipate other demand scenarios. In Dou et al. (2009), the authors study flow-oriented RMS for producing a part family. They use a genetic algorithm (GA) to minimize the capital cost related to a chosen configuration, which is composed of a

set of RMT. An extension of this problem is addressed by Dou et al. (2016), where the authors take additionally into account parts scheduling. A multi-objective mixed-integer programming model and a non-dominated sorting genetic algorithm-II (NSGA-II) are proposed to minimize the capital cost and the total tardiness. A methodology for a multi-product RMS configuration design in a multi-period environment is presented by Saxena and Jain (2012). The objective is to minimize the capital cost of reconfiguration for all periods. Ashraf and Hasan (2018) seek efficient (in sense of Pareto) RMT configurations in a reconfigurable serial product flow line. The objectives, achieved by using an NSGA-II, are the minimization of the cost related to a selected configuration and the maximization of reconfigurability, operational capability and reliability of machines.

In Bensmaine et al. (2014) and Chaube et al. (2010), a multi-product RMS, composed of RMT, is considered. The objective consists in finding a set of efficient configurations of RMT in order to produce a particular product while minimizing the total completion time as well as the manufacturing cost. The former develops a heuristic while the latter uses an NSGA-II. Goyal and Jain (2015) and Goyal et al. (2012) generate a configuration of a single part flow line, composed of RMT, able to perform different tasks by changing their auxiliary modules. The authors introduce two performance measures, which are the machine reconfigurability and the operational capability. The three objectives are to minimize the investment cost and to maximize the aforementioned performance measures. For this purpose, Goyal et al. (2012) apply an NSGA-II, while a multi-objective particle swarm optimization (MOPSO) is used by Goyal and Jain (2015).

The objective in Asghar et al. (2018) is to generate a reconfigurable process plan with optimal machine configurations that are able to cope with different demand scenarios. While in Benderbal et al. (2017a), the authors address the problem of an RMS design under unavailability constraints of machines. They use an NSGA-II to maximize the flexibility index of the system and to minimize the total completion time. Benderbal et al. (2017b) design a single product RMS by selecting from a set of available modular machines the most suitable ones in order to minimize the completion time and the cost of the system, and to maximize the system modularity. This is achieved by using an archived multi-objective simulated annealing (AMOS). Battaïa et al. (2016) propose a MIP formulation as a decision support tool for designing reconfigurable rotary machining systems, which are composed of modules of turrets and spindle heads. The objective is to minimize the total equipment cost.

By contrast to DML, which are designed for a single product/part only, RMS focus on a part family. However, some DML, such as assembly or transfer lines, could be modified to deal with product changes and unpredictable events, which consequently involve more time and costs compared with RMS. Nevertheless, such modifications may be considered as a reconfiguration. Therefore, the papers dealing with such problems are worth to be mentioned. For example, in Battaïa et al. (2019), the authors consider a hybrid flow line, composed of dedicated and reconfigurable machines. In such a line, the products are

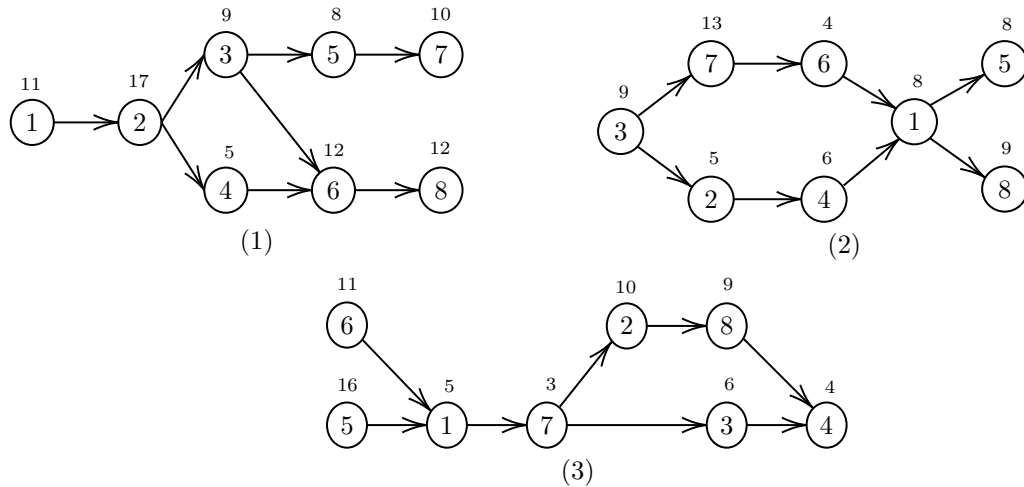

Fig. 1. (1), (2) and (3) are the precedence graphs that correspond to the products 1, 2 and 3.

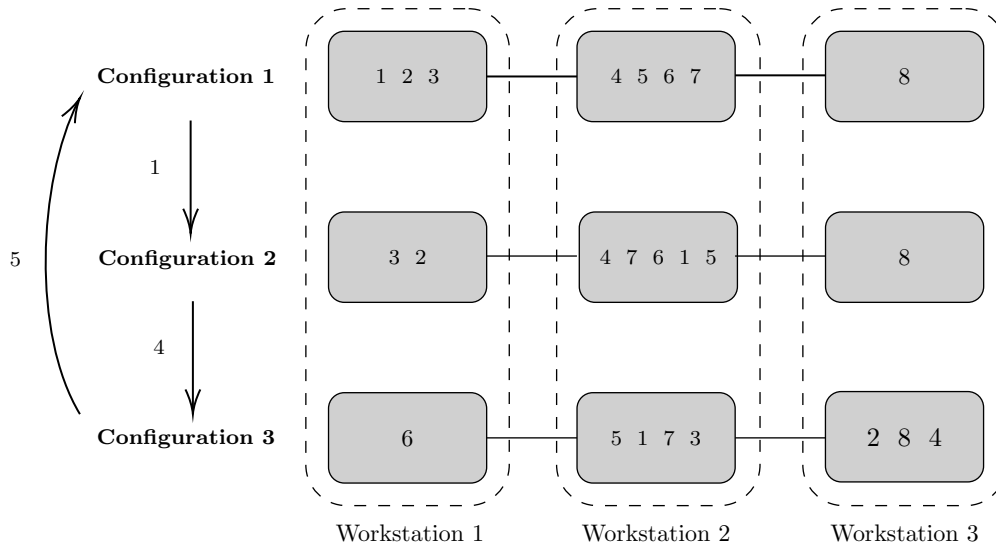

Fig. 2. Optimal product configurations that minimizes the number of reassignments.

manufactured in batches, and the aim is to find the number of reconfigurable machines, as well as their appropriate configurations, which, among others, include module selection and task assignments, while taking into consideration a given set of constraints. The objective function consists at minimizing the equipment cost, which includes the machine, module and operational costs.

Another widely studied problems in the literature concerns assembly lines. Those problems are referred to as assembly line re-balancing problems (ALRBP). They consist in adapting an existing assembly line to external changes by reassigning tasks in order to preserve the line admissibility and achieve a desired performance in terms of production capacity and costs. Such problems are tackled in Gamberini et al. (2006, 2009). The authors consider a manual assembly line, where tasks are performed by operators who need to be retrained during the re-balancing process. The task processing time is stochastic and the objectives are to find a trade-off between the expected completion time and the similarity between an initial and a re-balanced line. To solve this problem, a multi-objective heuristic is proposed by Gamberini et al. (2006), where a TOPSIS

method is used to select an appropriate efficient solution. While in Gamberini et al. (2009), the authors additionally develop three other heuristics and combine them in order to obtain a good approximation of the Pareto front. Sancı and Azizoğlu (2017) tackle the ALRBP, where workstation breakdowns occur and the corresponding tasks need to be reassigned to the other undisturbed workstations. The objectives are to minimize the cycle time and the number of reassigned tasks of the re-balanced assembly line. Finally, the closest problem to the one described in this paper is tackled in Makssoud et al. (2015). The authors consider an ALRBP with the objective to minimize the number of modifications when switching from a given initial assembly line configuration to a new one in order to meet with unexpected product changes. In this paper, we aim at designing an RMS in order to manufacture an already known set of products and minimizing the total number of reassignments when switching between all corresponding product configurations.

### 3. PROBLEM FORMULATION

In this section, a mixed integer linear programming formulation of the studied optimization problem is given. The used notations and variables are introduced below.

#### Notations:

- $V$  is a set of tasks;
- $W$  is a set of available workstations;
- $P$  is a set of products;
- $C$  is the cycle time;
- $t_i^{(p)}$  is a processing time of the task  $i \in V$  for the product  $p \in P$ ;
- $G^{(p)} = (V, A^{(p)})$  is a directed acyclic graph representing the precedence constraints of the product  $p \in P$ . Here,  $A^{(p)}$  is the set of arcs for  $G^{(p)}$ , where an arc  $(i, j) \in A^{(p)}$  means that the task  $j$  has to be assigned either to the same workstation as the task  $i$ , or to succeeding ones.

#### Variables:

- $x_{ik}^{(p)}$  is equal to 1 if the task  $i \in V$  is assigned to the workstation  $k \in W$  in the configuration corresponding to the product  $p \in P$ , 0 otherwise.
- $z_{ik}^{(1,2)}$  (resp.  $z_{ik}^{(2,3)}, \dots, z_{ik}^{(|P|,1)}$ ) is equal to 0 if the task  $i \in V$  is assigned (or not assigned) to the workstation  $k \in W$  in both configurations corresponding to the products 1 and 2 (resp. 2 and 3, ...,  $|P|$  and 1), 1 otherwise.

$$\min \frac{1}{2} \sum_{i \in V} \sum_{k \in W} \left( z_{ik}^{(1,2)} + z_{ik}^{(2,3)} + \dots + z_{ik}^{(|P|,1)} \right) \quad \text{s.t.} \quad (1)$$

$$\left. \begin{aligned} -z_{ik}^{(1,2)} &\leq x_{ik}^{(1)} - x_{ik}^{(2)} \leq z_{ik}^{(1,2)}, \quad \forall i \in V, \quad \forall k \in W \\ -z_{ik}^{(2,3)} &\leq x_{ik}^{(2)} - x_{ik}^{(3)} \leq z_{ik}^{(2,3)}, \quad \forall i \in V, \quad \forall k \in W \\ &\dots \\ -z_{ik}^{(|P|,1)} &\leq x_{ik}^{(|P|)} - x_{ik}^{(1)} \leq z_{ik}^{(|P|,1)}, \quad \forall i \in V, \quad \forall k \in W \end{aligned} \right\} \quad (2)$$

$$\sum_{k \in W} x_{ik}^{(p)} = 1, \quad \forall i \in V, \quad \forall p \in P \quad (3)$$

$$\sum_{i \in V} x_{ik}^{(p)} \geq 1, \quad \forall k \in W, \quad \forall p \in P \quad (4)$$

$$\sum_{k \in W} k \cdot x_{ik}^{(p)} \leq \sum_{k \in W} k \cdot x_{jk}^{(p)}, \quad \forall (i, j) \in A^{(p)}, \quad \forall p \in P \quad (5)$$

$$\sum_{i \in V} t_i^{(p)} \cdot x_{ik}^{(p)} \leq C, \quad \forall k \in W, \quad \forall p \in P \quad (6)$$

$$x_{ik}^{(p)} = 0, \quad \forall i \in V, \quad \forall k \notin Q_i^{(p)}, \quad \forall p \in P \quad (7)$$

$$\begin{aligned} x_{ik}^{(p)} &\in \{0, 1\}, \quad \forall i \in V, \quad \forall k \in W, \quad \forall p \in P \\ z_{ik}^{(1,2)}, z_{ik}^{(2,3)}, \dots, z_{ik}^{(|P|,1)} &\geq 0, \quad \forall i \in V, \quad \forall k \in W \end{aligned}$$

Objective function (1) minimizes the total number of reassignments necessary for switching between configurations corresponding to the products 1 and 2, 2 and 3, etc., up to the last product configuration  $|P|$  and 1. Constraints (2) check if a task is assigned to the same workstation in two successive product configurations. For example,  $z_{ik}^{(1,2)} = 0$  means that the task  $i$  is assigned to the workstation  $k$  in both configurations 1 and 2. Thus, the task  $i$  does not need to be reassigned when switching between these configurations. Otherwise,  $z_{ik}^{(1,2)} = 1$ . Constraints (3) and (4) ensure respectively for all configurations that each task is assigned to exactly one workstation, and each workstation possesses

at least one assigned task. The precedence constraints for each product are expressed by inequalities (5). Constraints (6) provide that the cycle time for each workstation in any configuration is not exceeded. Finally, constraints (7) induce that the task  $i$  can only be allocated to a restricted set of workstations, denoted by the interval  $Q_i^{(p)}$ , where

$$Q_i^{(p)} = \left[ \left\lfloor \frac{t_i^{(p)} + \sum_{j \in \mathcal{P}_i^{(p)}} t_j^{(p)}}{C} \right\rfloor, |W| + 1 - \left\lfloor \frac{t_i^{(p)} + \sum_{j \in \mathcal{S}_i^{(p)}} t_j^{(p)}}{C} \right\rfloor \right].$$

Here,  $\mathcal{P}_i^{(p)}$  (resp.  $\mathcal{S}_i^{(p)}$ ) represents the set of all predecessors (resp. all successors) of the task  $i$  with respect to the precedence graph  $G^{(p)}$  of the product  $p$ .

The proposed MILP model is a generic approach. Nevertheless, it can be adapted and easily modified to cope with real cases from the industry, where each reassignment could be associated with a cost or a time. Moreover, other technological constraints could be added such as inclusion and exclusion constraints.

### 4. COMPUTATIONAL RESULTS

In order to test the previously described MILP model, two categories of instances with respectively 20 and 50 tasks were used for the cases of two and three products ( $|P| = 2$  and  $|P| = 3$ ). These instances are based on those provided by Otto et al. (2013). In this paper, each category is grouped into three series of instances according to the density of their corresponding precedence graphs, known as the order strength ( $OS$ ). The latter is computed as the ratio of the number of arcs in its transitive closure, to the number of arcs in the complete graph (Otto et al., 2013):

$$OS = \frac{2 \cdot |E^{(p)}|}{|V|(|V| - 1)},$$

where  $E^{(p)} = \{(i, j) \mid i \in V, j \in \mathcal{S}_i^{(p)}\}$  is the set of arcs in the transitive closure of  $G^{(p)}$ . For example, the order strength of the precedence graph (1) (shown in Fig. 1) is  $(2 \times 21) / (8 \times 7) = 0.75$ . Similarly, 0.82 and 0.89, correspond to the value of  $OS$  for precedence graphs (2) and (3).

As a result, the first series corresponds to the instances having  $OS \in [0.1, 0.3]$ , the second one concerns those with  $OS \in [0.3, 0.6]$ , and finally the third one is for  $OS \in [0.6, 1.0]$ . Additionally, for each instance, the computation time is limited to 600 seconds,  $C = 1000$  and

$$|W| = \max_{p \in P} \left\{ \left\lceil 1.4 \cdot \frac{\sum_{i \in V} t_i^{(p)}}{C} \right\rceil \right\}$$

The MILP model is solved using CPLEX 12.9, installed on an 1.90GHz Intel(R) Core(TM) i7-8650U computer with 32 GB RAM. The results are expressed in Table 1, where the first column represents the number of products. The second column addresses the category of instances, each divided into three distinct series as illustrated in the third column. The fourth one presents the total number of instances in each series. The number of instances solved to optimality as well as their average CPU time are shown in the fifth and last columns, respectively. While the instances for which no optimal solution was found are

Table 1. Summary of computational results for  $|P| = 2$  and  $|P| = 3$ .

$ P $	$ V $	Series	#Instances	#OPT	Avg. GAP, (%)	Avg. CPU, (s.)
2	20	1	224	224	⊕	6.22
		2	241	241	⊕	4.14
		3	76	76	⊕	0.68
	50	1	224	41	76.10	268.55
		2	184	39	56.61	262.63
		3	118	48	43.75	166.40
3	20	1	223	200	27.47	77.25
		2	240	217	17.26	62.82
		3	75	75	⊕	16.00
	50	1	223	0	89.27	⊖
		2	183	0	72.11	⊖
		3	89	4	49.55	391.00

(⊕) All optimal solutions were found within the maximum CPU time of 600 seconds.

(⊖) No optimal solution was found within the maximum CPU time of 600 seconds.

expressed by their average GAP in the sixth column. The GAP is calculated as

$$\text{GAP} = \frac{(UB - LB)}{UB} \cdot 100\%,$$

where  $UB$  is the value of the objective function for the best found integer feasible solution and  $LB$  is the best lower bound.

Analyzing Table 1, it is interesting to notice the difference between the two categories of instances concerning both cases corresponding to  $|P| = 2$  and  $|P| = 3$ . For  $|P| = 2$ , any instance of the first category ( $|V| = 20$ ) was optimally solved in less than 7 seconds in average, whereas in the second one ( $|V| = 50$ ), only 128 instances among 541 (23.66%) were solved to optimality. The case of  $|P| = 3$  provides similar results, where in the first category ( $|V| = 20$ ) 492 among 538 instances (91.45%) were optimally solved versus only 4 instances out of 495 (0.8%) for the second category. As a result, we notice that the number of optimally solved instances as well as the average GAP and CPU time are affected by the number of products as well as the series, meaning that the smaller the  $OS$  value the higher the average GAP and CPU time, and the lower the number of products, the lower the average GAP and CPU time.

Despite the problem complexity and in view of the obtained results, the proposed MILP model was able to successfully address the instances of the first category in both cases corresponding to  $|P| = 2$  and  $|P| = 3$ . Unfortunately, it finds its limits when solving instances with 50 tasks. It is also worth to highlight that the MILP model was tested on complex instances, where precedence constraints are strongly different from each other, which is not always the case in the industry.

## 5. CONCLUSION AND PERSPECTIVES

This paper tackled the design problem of a multi-product reconfigurable line. Given a set of products belonging to a same family, the objective was to generate optimal configurations for each one of them in order to minimize the number of reassigned tasks when switching from one configuration to another. For this purpose, a MILP formulation was developed and tested on two categories of instances corresponding respectively to 20 and 50 tasks. Numerical results have shown that the used commercial

solver can find optimal solutions in less than 10 minutes for the instances belonging to the first category. Whereas only few of them were optimally solved regarding the second category of instances.

The proposed MILP model was a first attempt to address the studied problem. The obtained results were promising, but not satisfactory especially for medium size (and consequently for large size) instances. Hence, for our future research, we are looking forward to develop a branch and bound method to provide optimal solutions faster, on the one hand, and to implement a heuristic for seeking good quality solutions close to optimum on the other hand.

## ACKNOWLEDGEMENTS

This work was financially supported by the IRT PERFORMANCE program, managed by IRT Jules Verne (French Institute in Research and Technology in Advanced Manufacturing).

## REFERENCES

- Asghar, E., uz Zaman, U.K., Baqai, A.A., and Homri, L. (2018). Optimum machine capabilities for reconfigurable manufacturing systems. *The International Journal of Advanced Manufacturing Technology*, 95(9-12), 4397–4417.
- Ashraf, M. and Hasan, F. (2018). Configuration selection for a reconfigurable manufacturing flow line involving part production with operation constraints. *The International Journal of Advanced Manufacturing Technology*, 98(5-8), 2137–2156.
- Battaïa, O., Dolgui, A., and Guschinsky, N. (2016). Decision support for design of reconfigurable rotary machining systems for family part production. *International Journal of Production Research*, 55(5), 1368–1385.
- Battaïa, O., Dolgui, A., and Guschinsky, N. (2019). Optimal cost design of flow lines with reconfigurable machines for batch production. *International Journal of Production Research (accepted, available online)*.
- Benderbal, H.H., Dahane, M., and Benyoucef, L. (2017a). Flexibility-based multi-objective approach for machines selection in reconfigurable manufacturing system (RMS) design under unavailability constraints. *International Journal of Production Research*, 55(20), 6033–6051.
- Benderbal, H.H., Dahane, M., and Benyoucef, L. (2017b). Modularity assessment in reconfigurable manufacturing

- system (RMS) design: an archived multi-objective simulated annealing-based approach. *The International Journal of Advanced Manufacturing Technology*, 94(1-4), 729–749.
- Bensmaine, A., Benyoucef, L., and Dahane, D. (2014). A new heuristic for integrated process planning and scheduling in reconfigurable manufacturing systems. *International Journal of Production Research*, 52(12), 3583–3594.
- Bortolini, M., Galizia, F., and Mora, C. (2018). Reconfigurable manufacturing systems: Literature review and research trend. *Journal of Manufacturing Systems*, 49, 93–106.
- Brahimi, N., Dolgui, A., Gurevsky, E., and Yelles-Chaouche, A.R. (2019). A literature review of optimization problems for reconfigurable manufacturing systems. In *9th IFAC Conference on Manufacturing Modelling, Management and Control (MIM 2019), Berlin, Germany*, 6 pages.
- Chaube, A., Benyoucef, L., and Tiwari, M.K. (2010). An adapted NSGA-2 algorithm based dynamic process plan generation for a reconfigurable manufacturing system. *Journal of Intelligent Manufacturing*, 23(4), 1141–1155.
- Dou, J., Dai, X., and Meng, Z. (2009). Optimisation for multi-part flow-line configuration of reconfigurable manufacturing system using GA. *International Journal of Production Research*, 48(14), 4071–4100.
- Dou, J., Li, J., and Su, C. (2016). Bi-objective optimization of integrating configuration generation and scheduling for reconfigurable flow lines using NSGA-II. *The International Journal of Advanced Manufacturing Technology*, 86(5-8), 1945–1962.
- Gamberini, R., Gebennini, E., Grassi, A., and Regattieri, A. (2009). A multiple single-pass heuristic algorithm solving the stochastic assembly line rebalancing problem. *International Journal of Production Research*, 47(8), 2141–2164.
- Gamberini, R., Grassi, A., and Rimini, B. (2006). A new multi-objective heuristic algorithm for solving the stochastic assembly line re-balancing problem. *International Journal of Production Economics*, 102(2), 226–243.
- Goyal, K.K. and Jain, P.K. (2015). Design of reconfigurable flow lines using MOPSO and maximum deviation theory. *The International Journal of Advanced Manufacturing Technology*, 84(5-8), 1587–1600.
- Goyal, K.K., Jain, P.K., and Jain, M. (2012). Optimal configuration selection for reconfigurable manufacturing system using NSGA II and TOPSIS. *International Journal of Production Research*, 50(15), 4175–4191.
- Koren, Y., Heisel, U., Jovane, F., Moriwaki, T., Pritschow, G., Ulsoy, G., and Van Brussel, H. (1999). Reconfigurable manufacturing systems. In *Manufacturing Technologies for Machines of the Future*, 627–665. Springer Berlin Heidelberg.
- Koren, Y. and Shpitalni, M. (2010). Design of reconfigurable manufacturing systems. *Journal of Manufacturing Systems*, 29(4), 130–141.
- Koren, Y., Wang, W., and Gu, X. (2016). Value creation through design for scalability of reconfigurable manufacturing systems. *International Journal of Production Research*, 55(5), 1227–1242.
- Makssoud, F., Battaïa, O., Dolgui, A., Mporfu, K., and Olabanji, O. (2015). Re-balancing problem for assembly lines: new mathematical model and exact solution method. *Assembly Automation*, 35(1), 16–21.
- Otto, A., Otto, C., and Scholl, A. (2013). Systematic data generation and test design for solution algorithms on the example of SALBPGen for assembly line balancing. *European Journal of Operational Research*, 228(1), 33–45.
- Sanci, E. and Azizoglu, M. (2017). Rebalancing the assembly lines: exact solution approaches. *International Journal of Production Research*, 55(20), 5991–6010.
- Saxena, L.K. and Jain, P.K. (2012). A model and optimisation approach for reconfigurable manufacturing system configuration design. *International Journal of Production Research*, 50(12), 3359–3381.
- Youssef, A.M.A. and ElMaraghy, H.A. (2007). Optimal configuration selection for reconfigurable manufacturing systems. *International Journal of Flexible Manufacturing Systems*, 19(2), 67–106.