



HAL
open science

Complexity and algorithms for injective edge-coloring in graphs

Florent Foucaud, Hervé Hocquard, Dimitri Lajou

► **To cite this version:**

Florent Foucaud, Hervé Hocquard, Dimitri Lajou. Complexity and algorithms for injective edge-coloring in graphs. *Information Processing Letters*, 2021, 170, pp.106121. 10.1016/j.ipl.2021.106121 . hal-03201544

HAL Id: hal-03201544

<https://hal.science/hal-03201544v1>

Submitted on 19 Apr 2021

HAL is a multi-disciplinary open access archive for the deposit and dissemination of scientific research documents, whether they are published or not. The documents may come from teaching and research institutions in France or abroad, or from public or private research centers.

L'archive ouverte pluridisciplinaire **HAL**, est destinée au dépôt et à la diffusion de documents scientifiques de niveau recherche, publiés ou non, émanant des établissements d'enseignement et de recherche français ou étrangers, des laboratoires publics ou privés.

Complexity and algorithms for injective edge-coloring in graphs*

Florent Foucaud^{†‡§}

Hervé Hocquard[‡]

Dimitri Lajou[‡]

April 16, 2021

Abstract

An injective k -edge-coloring of a graph G is an assignment of colors, i.e. integers in $\{1, \dots, k\}$, to the edges of G such that any two edges each incident with one distinct endpoint of a third edge, receive distinct colors. The problem of determining whether such a k -coloring exists is called INJECTIVE k -EDGE-COLORING. We show that INJECTIVE 3-EDGE-COLORING is NP-complete, even for triangle-free cubic graphs, planar subcubic graphs of arbitrarily large girth, and planar bipartite subcubic graphs of girth 6. INJECTIVE 4-EDGE-COLORING remains NP-complete for cubic graphs. For any $k \geq 45$, we show that INJECTIVE k -EDGE-COLORING remains NP-complete even for graphs of maximum degree at most $5\sqrt{3}k$. In contrast with these negative results, we show that INJECTIVE k -EDGE-COLORING is linear-time solvable on graphs of bounded treewidth. Moreover, we show that all planar bipartite subcubic graphs of girth at least 16 are injectively 3-edge-colorable. In addition, any graph of maximum degree at most $\sqrt{k/2}$ is injectively k -edge-colorable.

1 Introduction

We study the algorithmic complexity of the injective edge-coloring problem. Our aim is to determine restricted graph classes where the problem is NP-hard, while in contrast, designing algorithms for other graph classes. An *injective k -edge-coloring* of a graph $G = (V(G), E(G))$ is an assignment of colors, i.e. integers in $\{1, \dots, k\}$, to the edges of G in such a way that two edges that are each incident with one distinct endpoint of a third edge, receive distinct colors. In other words, for any 3-edge path of G (possibly forming a triangle), the first and last edge of the path receive distinct colors. The *injective chromatic index* of G , denoted $\chi'_i(G)$, is the least integer k for which G admits an injective k -edge-coloring.

This concept was recently introduced in [4], where it is studied for some classes of graphs, and proved to be NP-complete. Bounds on the injective chromatic index of planar graphs, graphs of given maximum degree, and other important graph classes, have been recently determined in [1, 3, 7, 14, 16]. In particular, as mentioned in [7], it follows from [1] that all planar graphs are injectively 30-edge-colorable, while outerplanar graphs are injectively 9-edge-colorable [7]. It is also proved in [14] that subcubic graphs are injectively 7-edge-colorable, while subcubic bipartite graphs [7] and subcubic planar graphs [14] are injectively 6-edge-colorable. Moreover all subcubic planar bipartite graphs are injectively 4-edge-colorable [14].

Note that in [1], this notion is studied as the *induced star arboricity* of a graph, that is, the smallest number of star forests into which the edges of the graph can be partitioned: this is an equivalent way to interpret injective edge-coloring (see [7]). The concept of an injective edge-coloring is the natural edge-version of the notion of an injective vertex-coloring, introduced in [10] and well-studied since then.

Another closely related notion is the one of *strong edge-coloring* of a graph G , introduced in [8] and well-studied since then, especially in view of a celebrated conjecture by Erdős and Nešetřil [6]. In this type of coloring, edges that are the endpoints of a same 3-edge path *or* 2-edge path must receive distinct colors. The *strong chromatic index* $\chi'_s(G)$ of a graph G is the least integer k for which G admits a strong edge-coloring with k colors. It follows from the definitions that for any graph G , $\chi'_i(G) \leq \chi'_s(G)$ holds.

The algorithmic complexity of determining the strong chromatic index of a graph is well-studied, see for example [12] for a classic reference, and [5, 11] for more recent ones. In this paper, we wish to undertake similar types of studies for the injective chromatic index. The problem at hand is formally defined as follows.

*This research was supported by the IFCAM project “Applications of graph homomorphisms” (MA/IFCAM/18/39) and by the ANR project HOSIGRA (ANR-17-CE40-0022).

[†]LIMOS, CNRS UMR 6158, Université Clermont Auvergne, Aubière, France.

[‡]Univ. Bordeaux, CNRS, Bordeaux INP, LaBRI, UMR5800, F-33400 Talence, France

[§]Univ. Orléans, INSA Centre Val de Loire, LIFO EA 4022, F-45067 Orléans, France.

INJECTIVE k -EDGE-COLORING

Instance: A graph G .

Question: Does G admit an injective k -edge-coloring?

INJECTIVE k -EDGE-COLORING was proved NP-complete (for every fixed $k \geq 3$) in [4], with no particular restriction on the inputs. We strengthen this as follows.

Theorem 1 *The two following are NP-Complete:*

1. INJECTIVE 3-EDGE-COLORING, even for triangle-free cubic graphs, and
2. INJECTIVE 4-EDGE-COLORING, even for cubic graphs.

Answering a question from [4] about the complexity of INJECTIVE k -EDGE-COLORING for planar graphs, we also study restricted subclasses of planar graphs.

Theorem 2 *Let $g \geq 3$. INJECTIVE 3-EDGE-COLORING is NP-Complete even for:*

1. planar subcubic graphs with girth at least g ,
2. planar bipartite subcubic graphs of girth 6.

The two items in Theorem 2 cannot be combined, because we can prove the following (note that all planar bipartite subcubic graphs are injectively 4-edge-colorable [14]).

Theorem 3 *Every planar bipartite subcubic graph of girth at least 16 is injectively 3-edge-colorable.*

We also obtain the following positive result ($tw(G)$ denotes the treewidth of G).

Theorem 4 *For every graph G of order n and every positive integer k , there exists a $2^{O(k \cdot tw(G)^2)}n$ -time algorithm that solves INJECTIVE k -EDGE-COLORING.*

It is proved in [1] that $\chi'_i(G) \leq 3 \binom{tw(G)}{2}$, and so using the above algorithm, one can determine the injective chromatic index of a graph of order n in time $2^{O(tw(G)^4)}n$.

Contrasting with our hardness results for planar graphs, Theorem 4 implies that INJECTIVE k -EDGE-COLORING can be solved in polynomial-time on subclasses of planar graphs: K_4 -minor-free graphs (i.e. graphs of treewidth 2), and thus, on outerplanar graphs.

In [4], Cardoso *et al.* use a reduction on graphs having their maximum degree linear in the number of colors. We improve it with the following result.

Theorem 5 *For every integer $k \geq 45$, INJECTIVE k -EDGE-COLORING is NP-Complete even for graphs with maximum degree at most $5\sqrt{3k}$.*

The bound of Theorem 5 is tight up to a constant factor: by a standard maximum degree argument of a conflict graph, every graph with maximum degree at most $\sqrt{k/2}$ is injectively k -edge-colorable. (Indeed, for every edge e of a graph G , there are at most $2(\Delta(G) - 1)^2$ edges which cannot have the same color as e , where $\Delta(G)$ is the maximum degree of G .)

2 Proof of Theorem 1

For these two problems, we reduce from 3-EDGE-COLORING, which is NP-Complete even for cubic graphs [12]. (Recall that a proper edge-coloring is an edge-coloring for which edges that are incident to a same vertex receive different colors.)

3-EDGE-COLORING

Instance: A cubic graph G .

Question: Does G admit a proper 3-edge-coloring?

2.1 Proof of Theorem 1.1

Proof. Let G be the input cubic graph. We will proceed in two steps: first, we create a triangle-free subcubic graph G' which has an injective 3-edge-coloring if and only if G is properly 3-edge-colorable. Then we describe how to make the graph cubic.

We create the graph G' from G by removing all the edges of G . For each edge uv of G , we create a copy of a gadget E_{uv} (see Figure 1(a) for an illustration) and connect it to u and v as follows. We add eight new vertices $w_{uv}, z_{uv}, a_{uv}, b_{uv}, c_{uv}, d_{uv}, e_{uv}$ and f_{uv} . We create the following edges $uw_{uv}, vw_{uv}, w_{uv}z_{uv}, z_{uv}a_{uv}, z_{uv}b_{uv}, a_{uv}c_{uv}, b_{uv}c_{uv}, a_{uv}d_{uv}, b_{uv}e_{uv}, c_{uv}f_{uv}, d_{uv}f_{uv}$ and $e_{uv}f_{uv}$.

Claim 6 E_{uv} is injectively 3-edge-colorable, and for every valid edge-coloring γ of E_{uv} , $\gamma(uw_{uv}) = \gamma(vw_{uv}) = \gamma(w_{uv}z_{uv})$. Moreover, for any choice of the same color for these three edges, we can extend the coloring to an injective 3-edge-coloring of E_{uv} .

Proof. Let us injectively 3-edge-color E_{uv} . W.l.o.g., we can assume that $d_{uv}f_{uv}$ is colored 1, $b_{uv}c_{uv}$ is colored 2 and $a_{uv}z_{uv}$ is colored 3. We deduce that $b_{uv}e_{uv}$ is colored 2, $c_{uv}f_{uv}$ is colored 1, $a_{uv}d_{uv}$ and $a_{uv}c_{uv}$ are colored 3, $b_{uv}z_{uv}$ is colored 2 and $e_{uv}f_{uv}$ is colored 1. Hence uw_{uv}, vw_{uv} and $w_{uv}z_{uv}$ must all be colored 1.

Now, given one same color for these three edges, one can color the rest of the gadget, for example using the previously constructed coloring. \blacksquare

If G has a proper 3-edge-coloring γ , we injectively 3-edge-color G' by assigning to uw_{uv}, vw_{uv} and $w_{uv}z_{uv}$ in G' the color $\gamma(uv)$; then we extend the coloring to each E_{uv} using Claim 6.

Conversely, if G' has an injective 3-edge-coloring, then we color an edge uv of G with the color of the edge uw_{uv} (or vw_{uv}) of G' . This coloring is proper since Claim 6 insures that uw_{uv} and vw_{uv} have the same color. Indeed if ux is an edge adjacent to uv , then uw_{uv} and xw_{ux} have different colors.

We now show how to make the construction cubic. We create the cubic graph G'' as follows. First, take three disjoint copies G_1, G_2 and G_3 of G' . To differentiate the vertices of each copy, we add an exponent to the name of the vertex corresponding to the number of the copy. For example, vertex w_{uv} of G_1 will be noted w_{uv}^1 . For each edge uv of G , connect G_1, G_2 and G_3 via $K_{1,3}$ with vertex classes $\{r_{uv}\}$ and $\{s_{uv}, p_{uv}, q_{uv}\}$ as follows. The vertex s_{uv} (resp. p_{uv} , resp. q_{uv}) is adjacent to d_{uv}^3 (resp. d_{uv}^1 , resp. d_{uv}^2), e_{uv}^2 (resp. e_{uv}^3 , resp. e_{uv}^1) and r_{uv} (see Figure 1(b)). The graph G'' is simply the graph where the edge gadget is represented in Figure 1 and for each $u \in V(G)$, the three copies of u^i for $i \in \{1, 2, 3\}$ are identified.

As G is cubic, G'' is triangle-free and cubic. Note that if G'' admits an injective 3-edge-coloring, then in particular G' also admits an injective 3-edge-coloring and thus by our previous arguments, G is properly 3-edge-colorable.

If G is properly 3-edge-colorable, then we fix such a coloring $\gamma : E(G) \rightarrow \{1, 2, 3\}$. For $i \in \{1, 2, 3\}$, we color the edges incident with w_{uv}^i with the color $\gamma(uv) + i$, where the colors are considered to be taken modulo 3 (considering $0 = 3$). Then it suffices to extend the obtained coloring to each edge gadget (see Figure 1). \square

2.2 Proof of Theorem 1.2

Proof. Let G be the input graph. For each vertex u of G , we replace it by the following vertex gadget S_u (see Figure 2). The gadget S_u is made of a 9-cycle $x_0^u x_1^u \dots x_8^u$ and three other vertices y_i^u ($i \in \{0, 3, 6\}$) that will be connected to the rest of the graph. We add the edges $x_1^u x_8^u, x_2^u x_4^u, x_5^u x_7^u, x_0^u y_0^u, x_3^u y_3^u$ and $x_6^u y_6^u$. For any edge-coloring γ of S_u , we note $C_i^u(\gamma) = \{\gamma(x_i^u x_{i+1}^u), \gamma(x_i^u x_{i-1}^u)\}$ where $i \in \{0, 3, 6\}$ and where the indices are taken modulo 9.

Claim 7 For every injective 4-edge-coloring γ of S_u and for every $i \in \{0, 3, 6\}$, the color $\gamma(x_i^u y_i^u)$ belongs to the set $C_i^u(\gamma)$. Moreover, $C_0^u(\gamma) \cup C_3^u(\gamma) \cup C_6^u(\gamma) = \{1, 2, 3, 4\}$ and there exists a color $a \in \{1, 2, 3, 4\}$ such that for all $i \in \{0, 3, 6\}$, $a \in C_i^u(\gamma)$.

Furthermore, for any choice of color for $x_0^u y_0^u, x_3^u y_3^u, x_6^u y_6^u$ and sets of colors $C_i^u(\gamma)$, $i \in \{0, 3, 6\}$ verifying the previous necessary conditions, there exists an injective 4-edge-coloring γ of S_u matching those choices.

Proof. Let us try to construct an injective 4-edge-coloring γ of S_u . Up to permuting the colors, we assume that $\gamma(x_0^u x_1^u) = 1$, $\gamma(x_0^u x_8^u) = 2$ and $\gamma(x_8^u x_1^u) = 3$. Note that $x_2^u x_4^u$ and $x_5^u x_7^u$ cannot both be colored 4, w.l.o.g. assume that $\gamma(x_2^u x_4^u) \neq 4$. Hence $\gamma(x_2^u x_4^u) = 2$ and $\gamma(x_2^u x_3^u) = 4$. Remark that $\gamma(x_5^u x_6^u) \neq 2$. Moreover $x_5^u x_7^u$ and $x_6^u x_7^u$ can only receive colors 1 or 4 and they must receive different colors. Hence

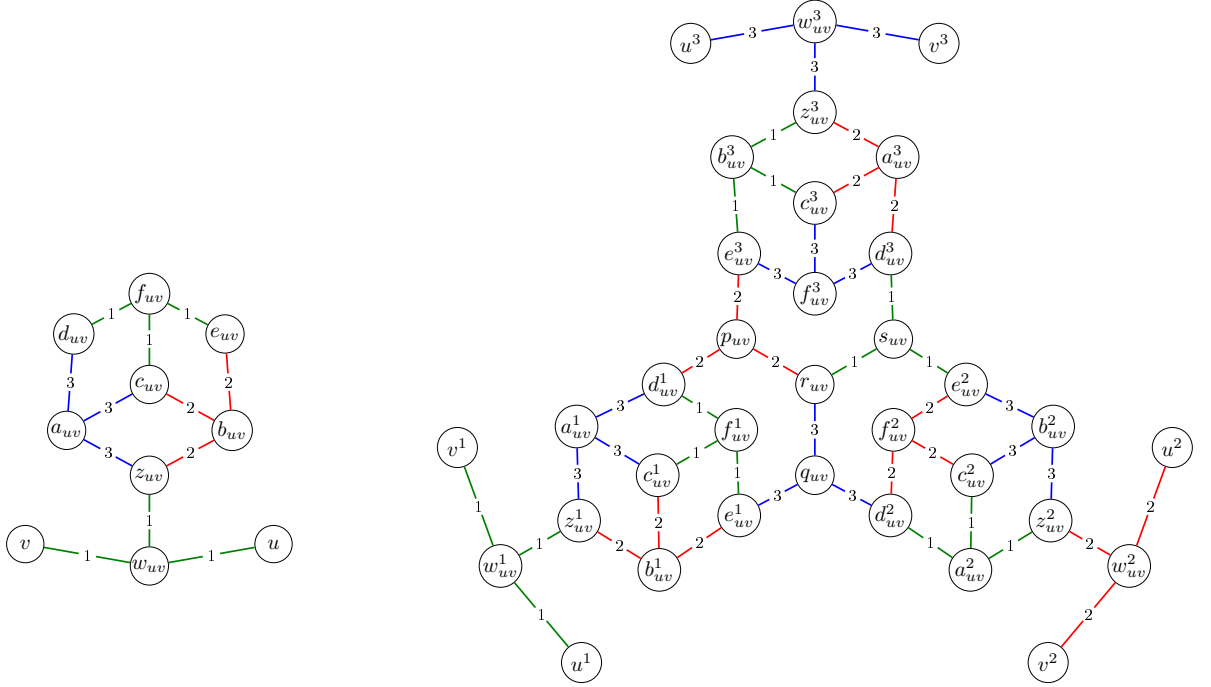

(a) Edge gadget E_{uv} with an injective 3-edge-coloring.

(b) Connecting three copies of E_{uv} in the construction of G'' , along with an injective 3-edge-coloring.

Figure 1: Edge gadgets used in the proof of Theorem 1.1.

$\gamma(x_5^u x_6^u) = 3$, $\gamma(x_3^u x_4^u) = 1$, $\gamma(x_5^u x_7^u) = 4$ and $\gamma(x_6^u x_7^u) = 1$. Now there are two ways to complete the coloring of S_u , either $\gamma(x_1^u x_2^u) = 4$, $\gamma(x_4^u x_5^u) = 3$ and $\gamma(x_7^u x_8^u) = 2$ or, $\gamma(x_1^u x_2^u) = 3$, $\gamma(x_4^u x_5^u) = 2$ and $\gamma(x_7^u x_8^u) = 4$. In both cases all properties of the first part of the claim hold (with $a = 1$).

Finally, note that the second of the two previous coloring options allows us to color $x_i^u y_i^u$, $i \in \{0, 3, 6\}$ with any color among those of $x_i^u x_{i+1}^u$ and $x_i^u x_{i-1}^u$, and to complete the coloring. ■

For every edge uv of G , we construct the following edge gadget E_{uv} (see Figure 2). First, choose y_i^u (resp. y_j^v) of degree 1 among the vertices of S_u (resp. S_v). Create two new adjacent vertices w_{uv} and z_{uv} such that $y_i^u w_{uv} y_j^v z_{uv}$ is a 4-cycle.

Claim 8 For every injective 4-edge-coloring γ of G and every edge gadget E_{uv} connecting y_i^u and y_j^v ($i, j \in \{0, 3, 6\}$), we have $C_i^u(\gamma) = C_j^v(\gamma)$.

Furthermore, any injective 4-edge-coloring γ of S_u and S_v such that $C_i^u(\gamma) = C_j^v(\gamma)$ and $\gamma(x_i^u y_i^u) = \gamma(x_j^v y_j^v)$ can be extended to an injective 4-edge-coloring of $S_u \cup E_{uv} \cup S_v$.

Proof. Suppose, w.l.o.g. by Claim 7, that $x_i^u x_{i+1}^u$ is colored 1, $x_i^u x_{i-1}^u$ is colored 2 and $x_i^u y_i^u$ is colored 1. Now w.l.o.g., $y_i^u w_{uv}$ is colored 3 and $y_i^u z_{uv}$ is colored 4. This implies that $w_{uv} z_{uv}$ is colored 2, $y_j^v w_{uv}$ is colored 3, $y_j^v z_{uv}$ is colored 4, $y_j^v x_j^v$ is colored 1 and $C_j^v(\gamma) = \{1, 2\}$.

The second part of the claim is proved by taking the previous coloring and extending it using the second part of Claim 7. ■

Let G' be the cubic graph constructed from G by the above process. By Claim 8, if uv is an edge connecting y_i^u and y_j^v then for any injective coloring γ of G' , $C_i^u(\gamma) = C_j^v(\gamma) = \{a, b\}$ for some a and b . Hence this set somehow characterizes the edge gadget E_{uv} , we say that E_{uv} is colored by $\{a, b\}$.

Suppose that there exists an injective 4-edge-coloring γ of G' . For each edge uv of G , we color uv depending on the coloring of E_{uv} . When E_{uv} is colored $\{1, 2\}$ or $\{3, 4\}$ (resp. $\{1, 3\}$ or $\{2, 4\}$, resp. $\{1, 4\}$ or $\{2, 3\}$) then we color uv by color 1 (resp. 2, resp. 3). We argue that this edge-coloring, noted γ , is proper. Indeed suppose it is not, then for some vertex u , w.l.o.g., uv and uw are both colored 1. This means that the coloring of G' is such that $C_i^u(\gamma) = C_j^v(\gamma)$ or $C_i^u(\gamma) \cap C_j^v(\gamma) = \emptyset$ for $i \neq j$ and $i, j \in \{0, 3, 6\}$. This contradicts Claim 7. Hence we get a proper 3-edge-coloring of G .

Conversely, suppose that there exists a proper 3-edge-coloring of G . In G' , we color each edge of the form $x_i^u y_i^u$ by 1. If an edge uv of G is colored 1 (resp. 2, resp. 3) then we assign the color $\{1, 2\}$ (resp.

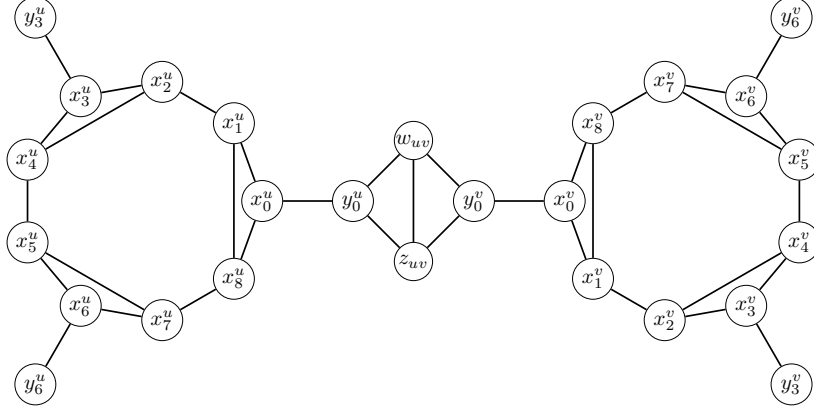

Figure 2: Two vertex gadgets S_u and S_v , corresponding to the vertices u and v of a graph G , connected by an edge gadget corresponding to the edge uv of G .

$\{1, 3\}$, resp. $\{1, 4\}$) to E_{uv} . By Claim 7, this coloring can be extended to an injective 4-edge-coloring of each S_u , $u \in V(G)$. By Claim 8, this injective 4-edge-coloring can be extended to each edge gadget to color the whole graph. \square

3 Proof of Theorem 2

We will reduce from the following problem:

PLANAR 3-VERTEX-COLORING

Instance: A planar graph G with maximum degree 4.

Question: Does G admit a proper 3-vertex-coloring?

This problem was proven to be NP-Complete in [9]. Let G be a planar graph with maximum degree 4.

3.1 Proof of Theorem 2.1

Proof. Recall that we want to construct a graph G' with girth at least g .

For each vertex $u \in V(G)$, we construct a vertex gadget S_u as follows (see Figure 3). First create a cycle $x_1^u x_2^u \dots x_\ell^u$ where $\ell \geq g$ and ℓ is an odd multiple of 3. To each x_i^u add a single pendant neighbor y_i^u of degree 1. To the vertex y_1^u , add two non-adjacent neighbors w^u and z^u . Create four more vertices a_1^u, b_1^u, c_1^u and d_1^u . The vertex w^u is adjacent to a_1^u and b_1^u while z^u is adjacent to c_1^u and d_1^u . Now construct a path $a_1^u a_2^u \dots a_g^u$ of length g and add to each a_i^u for $i \leq g-1$ a pendant vertex of degree 1 called a_i^u . Similarly we create the vertices $b_1^u \dots b_g^u, b_1^u \dots b_{g-1}^u, c_1^u \dots c_g^u, c_1^u \dots c_{g-1}^u$ and $d_1^u \dots d_g^u, d_1^u \dots d_{g-1}^u$. Finally add a vertex α^u (resp. β^u , resp. γ^u , resp. δ^u) adjacent to a_g^u (resp. b_g^u , resp. c_g^u , resp. d_g^u).

Claim 9 For any injective 3-edge-coloring ρ of S_u , $\rho(a_g^u \alpha^u) = \rho(b_g^u \beta^u) = \rho(c_g^u \gamma^u) = \rho(d_g^u \delta^u)$. We call this color $\rho(S_u)$. Moreover, for any choice of a color $\rho(S_u)$, there exists an injective 3-edge-coloring ρ with these properties.

Proof. Suppose that there exists $i \in \{1, \dots, \ell\}$ such that the property $\mathcal{P}(i) := \rho(x_i^u x_{i+1}^u) = \rho(x_i^u y_i^u) \neq \rho(x_i^u x_{i-1}^u)$ holds (the indices are taken modulo ℓ , considering $0 = \ell$). Then $\mathcal{P}(i)$ holds for all $i \in \{1, \dots, \ell\}$. Indeed, take such an i , then $\rho(x_{i+1}^u x_{i+2}^u) = \rho(x_{i+1}^u y_{i+1}^u)$ is the color $\{1, 2, 3\} \setminus \{\rho(x_i^u y_i^u), \rho(x_i^u x_{i-1}^u)\}$. Hence the property holds for $i+1$, by induction it holds for every i . Note that the same can be said for the property $\mathcal{P}'(i) = \rho(x_i^u x_{i-1}^u) = \rho(x_i^u y_i^u) \neq \rho(x_i^u x_{i+1}^u)$. Also note that if $\rho(x_i^u x_{i-1}^u) = \rho(x_i^u x_{i+1}^u) \neq \rho(x_i^u y_i^u)$ then we have $\mathcal{P}(i+1)$ which is a contradiction because we do not have $\mathcal{P}(i)$.

Suppose now that for all i , neither $\mathcal{P}(i)$ nor $\mathcal{P}'(i)$ holds. This means that the edges incident to a vertex x_i^u are either of the same color, or of three distinct colors. If they have the same color, then the edges incident with x_{i+1}^u have three distinct colors, the ones incident to x_{i+2}^u have the same color, and so on. This would imply that the cycle $x_1^u \dots x_\ell^u$ is even, which is a contradiction. Moreover, if the edges incident to x_i^u have three distinct colors, then the edges incident to x_{i+1}^u (or x_{i-1}^u) would all have the same color, and therefore no injective 3-edge-coloring would be possible.

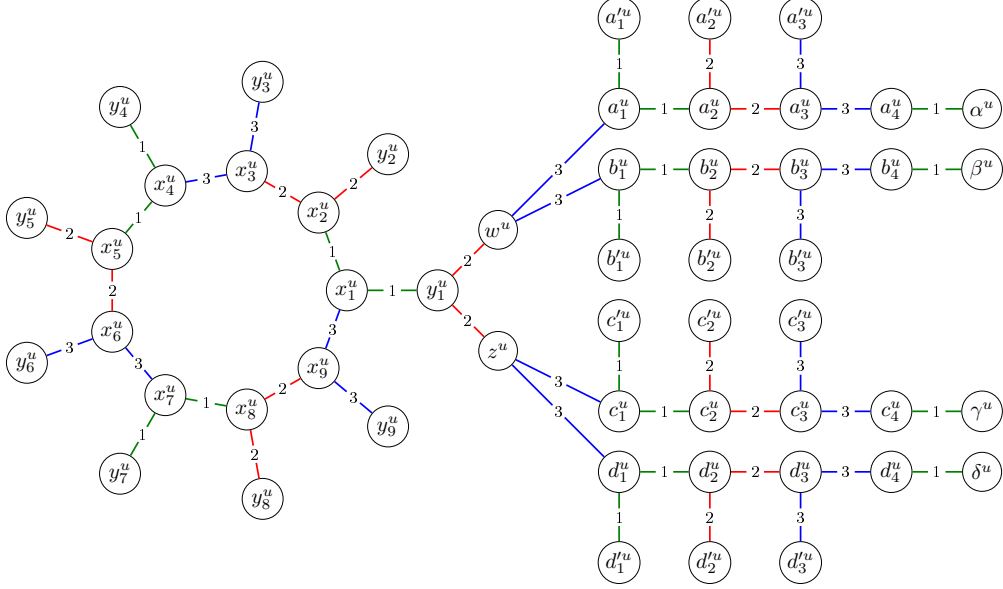

Figure 3: Vertex gadget S_u for planar subcubic graphs with girth at least g (in this example $g = 4$ and $\ell = 9$).

Thus, w.l.o.g. we can suppose that $\rho(x_1^u x_2^u) = \rho(x_1^u y_1^u) = 1$ and $\rho(x_1^u x_\ell^u) = 3$. By extending the coloring to the rest of S_u , we can infer that $\rho(y_1^u w^u) = \rho(y_1^u z^u) = 2$, $\rho(w^u a_1^u) = \rho(w^u b_1^u) = 3$ and $\rho(z^u c_1^u) = \rho(z^u d_1^u) = 3$. By the same reasoning, we can see that all the edges of S_u (ignoring the edges involving one of the vertices x_i^u) have only one possible color which depends only on their distance to y_1^u and in particular $\rho(a_g^u \alpha^u) = \rho(b_g^u \beta^u) = \rho(c_g^u \gamma^u) = \rho(d_g^u \delta^u)$.

Conversely, S_u admits a coloring (see Figure 3 for an example). To choose a coloring of S_u having the desired color $\rho(S_u)$, it suffices to permute the colors in the previous coloring. \blacksquare

To finish the construction, for any edge $uv \in E(G)$, we add an edge e^{uv} to G' between a vertex among $\{\alpha^u, \beta^u, \gamma^u, \delta^u\}$ and a vertex among $\{\alpha^v, \beta^v, \gamma^v, \delta^v\}$ such that the planarity of G' is preserved. This can be done by cyclically ordering the vertices of $\{\alpha^u, \beta^u, \gamma^u, \delta^u\}$ according to a planar embedding of G , and adding the edge e^{uv} between the right pair of vertices.

Note that G' is planar, subcubic with girth at least g .

Suppose that G' admits an injective 3-edge-coloring ρ . Assign to the vertex u of G the color $\rho(S_u)$. Take two adjacent vertices u and v of G . The edge e^{uv} in G' is an edge between two vertices, one of S_u and one of S_v : w.l.o.g. say $e^{uv} = \alpha^u \alpha^v$. This implies that $a_g^u \alpha^u$ and $a_g^v \alpha^v$ receive different colors and thus $\rho(S_u) \neq \rho(S_v)$. Hence this coloring of G is a proper 3-vertex-coloring.

Conversely, suppose that G admits a proper 3-vertex-coloring. Let ρ be a partial edge-coloring of G' with no colored edges. We choose the color $\rho(S_u)$ to be the color of u in G (and we color the appropriate edges of G'). By Claim 9, we can extend ρ to each gadget S_u . Note that by the choice of $\rho(S_u)$, there is no conflict between edges of S_u and S_v when u and v are adjacent in G . It is left to color the edges of the form e^{uv} . By construction, there are only two edges at distance 2 of e^{uv} (and this edge does not belong to a triangle). Hence there is at least one remaining color for e^{uv} . After coloring these edges, ρ is an injective 3-edge-coloring of G' . \square

3.2 Proof of Theorem 2.2

Proof. In order to prove this result, we will modify the previous construction to make it bipartite (the girth condition will be lost).

First we modify S_u (see Figure 4). Create the following gadget H . Start with a complete graph on four vertices x_1, \dots, x_4 . For each edge $x_i x_j$, create a vertex x_{ij} adjacent to both x_i and x_j and remove the edge $x_i x_j$. To each of these vertices of degree 2, add a pendant edge, with y_{ij} the vertex of degree 1 adjacent to x_{ij} .

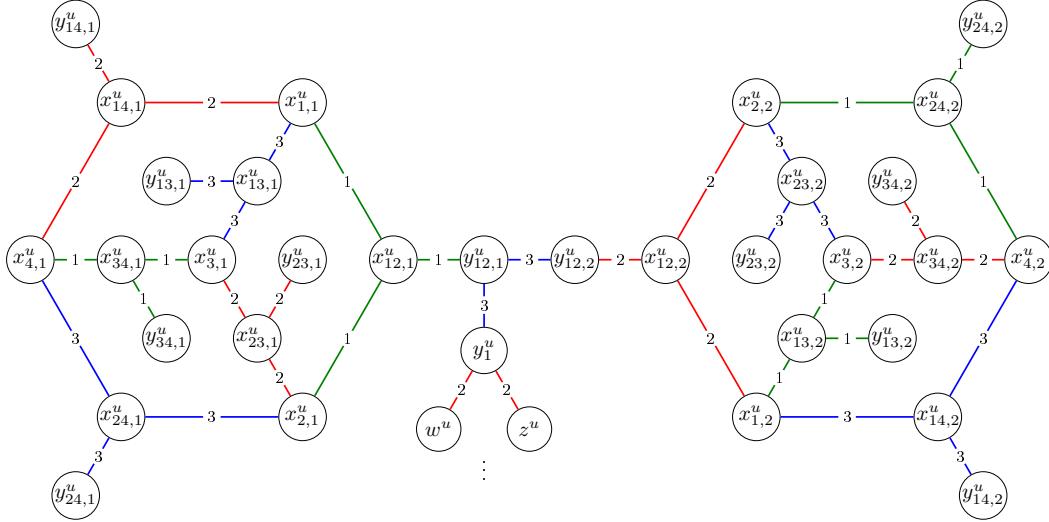

Figure 4: Vertex gadget for planar bipartite subcubic graphs with girth at least 6.

We claim that in every injective 3-edge-coloring γ of H , for any $i \neq j$, the vertex x_{ij} is incident to only one color. Suppose it is not the case, then there must exist an injective 3-edge-coloring γ for which we have one of $x_{12}x_2$ and $x_{12}x_1$ colored differently from $x_{12}y_{12}$, say w.l.o.g. $\gamma(x_{12}x_1) = 1$ and $\gamma(x_{12}y_{12}) = 2$. We deduce that $\gamma(x_2x_{23}) = \gamma(x_2x_{24}) = 3$, $\gamma(x_{14}x_4) = \gamma(x_3x_{13}) = 2$, $\gamma(x_3x_{34}) = 1$, and there is no color available for $x_{23}y_{23}$, a contradiction.

Now, take two disjoint copies of H named H_1^u and H_2^u . Add an edge between the two vertices $y_{12,1}^u$ and $y_{12,2}^u$ and add the edge $y_{12,1}^u y_1^u$ where y_1^u is a new vertex. Now repeat the construction process of S_u , for $g = 6$ for example, as described in the previous section by starting at the step where the vertices w^u and z^u are added. As we observed, the edges incident to vertex $x_{12,1}^u$ of H_1^u (resp. $x_{12,2}^u$ of H_2^u) have the same color in any injective 3-edge-coloring ρ . Hence, $\rho(y_{12,1}^u y_{12,2}^u) = \rho(y_{12,1}^u y_1^u) \neq \rho(x_{12,1}^u y_{12,1}^u)$. Note that this graph also admits an injective 3-edge-coloring (see Figure 4). We are in the same configuration as in the proof of Theorem 2.1. Thus Claim 9 also holds for this gadget S_u . Note that this gadget is bipartite.

The edge gadget does not change, it is still the edge e^{uv} . We need to be careful with the bipartiteness of the constructed graph. To ensure that the constructed graph is bipartite, it suffices that all vertices y_1^u , $u \in V(G)$, belong to the same part of the bipartition. To that end, if there is a path of odd length between y_1^u and y_1^v , then w.l.o.g. this path is $y_1^u a_1^u \dots a_g^u \alpha^u \alpha^v a_g^v \dots a_1^v y_1^v$. If we increase the length of a sequence $a_1^u \dots a_g^u$ in S_u by 3 (and also adding a_g^u , a_{g+1}^u and a_{g+2}^u), then this path now has even length. With this trick, we can ensure the bipartiteness of the constructed graph G' as well as keeping Claim 9 true in this new setting.

Hence, as before, G admits a proper vertex-3-coloring if and only if G' admits an injective 3-edge-coloring.

□

4 Proof of Theorem 3

Proof. Let G be a planar bipartite subcubic graph with girth at least 16. Let A and B be the two parts of the bipartition of G . We construct the graph G_A as follows: for each $u \in A$, we create a vertex u in G_A . For each pair of vertices u, v of A which are at distance 2, we add an edge between u and v in G_A . As G is subcubic, a planar embedding of G also serves as a planar embedding of G_A , where the edges of G_A follow their corresponding path of length 2 in G . Hence, G_A is a planar graph with maximum degree at most 6. Note that, by the girth condition on G , G_A does not have any k -cycle, for all k with $4 \leq k \leq 7$. Then, by the main result from [2], the graph G_A admits a vertex-3-coloring γ .

We now color G as follows: each edge uv of G , where $u \in A$ and $v \in B$, is colored by the color $\gamma(u)$ in G_A . We claim that this is an injective 3-edge-coloring of G . Indeed, take any path $uvwz$ of G . W.l.o.g., assume $u, w \in A$ and $v, z \in B$. By construction, $uw \in E(G_A)$ and thus uv and wz receive different colors.

□

5 Proof of Theorem 4

Proof. We give an fixed-parameter tractable (FPT) algorithm parameterized by the treewidth $tw(G)$ of our input graph G . We use a *nice tree decomposition* (see [13]) of the input graph for our dynamic programming algorithm. Nice tree decompositions are a well-known tool for designing algorithms on graphs of bounded treewidth using dynamic programming. In our notation, the set of vertices of the graph associated to a node v of the tree, its *bag*, is denoted X_v .

A nice tree decomposition of a graph is a tree decomposition, rooted at a node $Root$, with the following types of nodes. A *join node* has exactly two children, with the same bags as their parent join node. An *introduce node* has a unique child and contains exactly one more vertex in its bag than its child's bag. A *forget node* also has a unique child, but the forget node's bag has exactly one less vertex than its child's bag. A *leaf node* is a leaf of the tree and contains no vertices. We call $G_{\leq v}$ the subgraph of G induced by the subtree of the decomposition rooted at v and G_v the subgraph of G induced by X_v . We note $N_H(u)$ for the neighborhood of a vertex u in a subgraph H of G .

We define the following set associated with a node v :

$$\mathcal{T}_v = \{t_1 : X_v \rightarrow \mathcal{P}(\{1, 2, \dots, k\})^2\} \times \{t_2 : E(G_v) \rightarrow \{1, 2, \dots, k\}\},$$

where $\mathcal{P}(X)$ is the power set of X . For $T \in \mathcal{T}_v$ with $T = (t_1, t_2)$, to simplify notation, we note $T[u]$ for $t_1(u)$ when $u \in X_v$ and $T[e] = t_2(e)$ when $e \in E(G_v)$. For a vertex $u \in X_v$, we also note A_u and B_u the two sets such that $T[u] = t_1(u) = (A_u, B_u)$.

The set $\mathcal{V}_{al}(v)$ is the subset of \mathcal{T}_v such that $T \in \mathcal{V}_{al}(v)$ if and only if there exists an injective k -edge-coloring γ of $G_{\leq v}$ such that:

1. for all $u \in X_v$, $A_u = \{\gamma(uw), w \in V(G_{\leq v}) \setminus X_v\}$, i.e. A_u is the set of colors of the edges of $G_{\leq v}$ (not in G_v) incident with u ,
2. for all $u \in X_v$, $B_u = \{\gamma(zw), zw \in E(G_{\leq v}) \setminus E(G_v) \text{ and } z \in N_{G_{\leq v}}(u)\}$, i.e. B_u is the set of colors of the edges of $G_{\leq v}$ (not in G_v) at distance 2 of u (or contained in a triangle containing u),
3. for all $e \in E(G_v)$, $T[e]$ is the color $\gamma(e)$.

In this case we say that γ is *associated with* T . Note that for each injective k -edge-coloring of $G_{\leq v}$, there exists an associated $T \in \mathcal{T}_v$ and hence, $T \in \mathcal{V}_{al}(v)$. The set $\mathcal{V}_{al}(v)$ is thus the set of $T \in \mathcal{T}_v$ associated with an injective k -edge-coloring of $G_{\leq v}$.

Note that $\mathcal{V}_{al}(Root) \neq \emptyset$ if and only if there exists an injective k -edge-coloring of G . We will compute $\mathcal{V}_{al}(Root)$ with a dynamic programming algorithm. Also note that $|\mathcal{T}_v| \leq 2^{O(k \cdot tw(G)^2)}$.

First suppose that v is a leaf node. Then $\mathcal{V}_{al}(v) = \mathcal{T}_v = \{(\emptyset, \emptyset)\}$.

Suppose that v is a forget node where v' is its child node such that $X_v \cup \{a\} = X_{v'}$. Let $T \in \mathcal{T}_v$, $T \in \mathcal{V}_{al}(v)$ if and only if there exists an associated coloring γ of $G_{\leq v}$. This coloring γ is also a coloring of $G_{\leq v'}$ and thus is associated to a $T' \in \mathcal{V}_{al}(v')$. In this case, since T and T' share the same coloring γ , we have the following constraints on T and T' :

- for all $e \in E(G_v)$, $T[e] = T'[e] = \gamma(e)$,
- for all $u \in X_v$ such that $au \in E(G_{v'})$, $A_u = A'_u \cup \{T[au]\}$ and $B_u = B'_u \cup \{T[aw], w \in X_v \cap N_G(a), w \neq u\}$ where $T[u] = (A_u, B_u)$ and $T'[u] = (A'_u, B'_u)$,
- for all $u \in X_v$ such that $au \notin E(G_{v'})$, $A_u = A'_u$ and $B_u = B'_u \cup \{T[aw], w \in X_v \cap N_G(u) \cap N_G(a)\}$ where $T[u] = (A_u, B_u)$ and $T'[u] = (A'_u, B'_u)$.

The last two constraints reflect the fact that A_u and B_u must be updated after the removal of a . The only new colors that can be added to these sets come from edges incident with a . There are multiple cases, depending on whether u and a are adjacent or not, determining which colors of edges need to be added to these sets.

Hence, for all $T \in \mathcal{V}_{al}(v)$, it suffices to check whether there exists a $T' \in \mathcal{V}_{al}(v')$ for which the previous conditions are verified. This can be done in time $2^{O(k \cdot tw(G)^2)}$, as T is uniquely determined by T' in the above constraints.

Suppose that v is an introduce node where v' is its child node such that $X_v = X_{v'} \cup \{a\}$. Let $T \in \mathcal{T}_v$, $T \in \mathcal{V}_{al}(v)$ if and only if there exists an associated coloring γ of $G_{\leq v}$. This coloring γ is also a coloring of $G_{\leq v'}$ and thus is associated to a $T' \in \mathcal{V}_{al}(v')$. In other words T is associated to a coloring γ obtained by extending a coloring γ' associated to some $T' \in \mathcal{V}_{al}(v')$. Thus $T' \in \mathcal{V}_{al}(v')$, we have the following constraints on T and T' , in order to ensure that γ is the extension of γ' :

- for all $e \in E(G_{v'})$, $T[e] = T'[e]$,
- for all $u \in X_{v'}$, $T[u] = T'[u]$,
- for $T[a] = (A_a, B_a)$, $A_a = \emptyset$ and $B_a = \bigcup_{u \in X_v, ua \in E(G_v)} A_u$,
- the coloring of X_v is an injective k -edge-coloring,
- for all $ua \in E(G_v)$, $T[ua] \notin B_u \cup \bigcup_{u' \in X_v, u' \neq u, u'a \in E(G_v)} A_{u'}$.

The first two constraints correspond to the fact that γ is an extension of γ' . As a is a new vertex, $A_a = \emptyset$ and the only colors in B_a can be obtained by edges incident with some vertex $u \in X_v$ itself adjacent to a , hence the third constraint. The last two constraints correspond to the fact that the coloring of the new edges around a cannot be in conflict with edges already colored. The fourth constraint checks that no such conflict arises in X_v and the fifth constraint ensures that for each new edge ua the color $T[ua]$ does not appear around an edge at distance 2 from a or u . For each T' , there are at most $2^{tw(G)}$ possible candidates to be added to $\mathcal{V}_{al}(v)$. Hence $2^{O(k \cdot tw(G)^2)}$ time is sufficient to compute $\mathcal{V}_{al}(v)$ from $\mathcal{V}_{al}(v')$.

Suppose that v is a join node where v_1 and v_2 are its children nodes such that $X_v = X_{v_1} = X_{v_2}$. Let $T \in \mathcal{T}_v$, $T \in \mathcal{V}_{al}(v)$ if and only if there exists an associated coloring γ of $G_{\leq v}$. As both $G_{\leq v_1}$ and $G_{\leq v_2}$ are subgraphs of $G_{\leq v}$, γ is also a coloring of $G_{\leq v_i}$ ($i \in \{1, 2\}$) and thus is associated to a $T_i \in \mathcal{V}_{al}(v_i)$. In this case, since T , T_1 and T_2 share the same coloring γ , we have the following constraints on T , T_1 and T_2 :

- for all $e \in E(G_v)$, $T[e] = T_1[e] = T_2[e]$,
- for all $u \in X_v$, $A_u = A_u^1 \cup A_u^2$ and $B_u = B_u^1 \cup B_u^2$ where $T_i[u] = (A_u^i, B_u^i)$ for $i \in \{1, 2\}$,
- for all $uw \in E(G_v)$, $A_u \cap A_w = \emptyset$.

The last constraint corresponds to the fact that the coloring is an injective k -edge-coloring (*i.e.* with no conflicts between the two subtrees). Given $T_1 \in \mathcal{V}_{al}(v_1)$ and $T_2 \in \mathcal{V}_{al}(v_2)$, T is uniquely determined by the above constraints. Hence it suffices to try all the pairs of T_1, T_2 and when the obtained set T verifies all conditions, we can add it to $\mathcal{V}_{al}(v)$. This can be done in time $(2^{O(k \cdot tw(G)^2)})^2 = 2^{O(k \cdot tw(G)^2)}$. \square

6 Proof of Theorem 5

Proof. We reduce from k -EDGE-COLORING, proven to be NP-Complete even for k -regular graphs in [15].

k -EDGE-COLORING

Instance: A k -regular graph G .

Question: Does G admit a proper k -edge-coloring?

We choose p to be the largest integer such that $k = \binom{p}{2} + r$ (and thus $r < p$) and recall that $k \geq 45$. Moreover we set $\ell = 2p$.

Let G be the input k -regular graph. For $uv \in E(G)$, we define the edge gadget E_{uv} as follows (see Figure 5). First create the following vertices $a^{uv}, b^{uv}, x_1^{uv}, \dots, x_{p-3}^{uv}, c^{uv}, d^{uv}, e^{uv}, y_1^{uv}, \dots, y_r^{uv}, s_1^{uv}, \dots, s_{2\ell}^{uv}$. The vertices s_i^{uv} have degree 1 in E_{uv} and will be connected to the rest of the graph. The vertices $\{x_1^{uv}, \dots, x_{p-3}^{uv}, a^{uv}, b^{uv}, c^{uv}\}$ form a clique; this is also the case for $\{x_1^{uv}, \dots, x_{p-3}^{uv}, a^{uv}, b^{uv}, d^{uv}\}$ and $\{y_1^{uv}, \dots, y_r^{uv}, d^{uv}\}$. The vertex e^{uv} is adjacent to $c^{uv}, d^{uv}, x_1^{uv}, \dots, x_{p-3}^{uv}, s_1^{uv}, \dots, s_{2\ell}^{uv}$. In the case where $r = 0$, *i.e.* $k = \binom{p}{2}$, we delete d^{uv} .

Let u be a vertex of G with v_1, \dots, v_k its neighbors. We construct the vertex gadget S_u from $k \times \ell$ vertices $v_{1,1}, \dots, v_{1,\ell}, v_{2,1}, \dots, v_{k,\ell}$ and successively consider pairs v_i, v_j of neighbors. For each pair, we add an edge between one of $v_{i,1}, \dots, v_{i,\ell}$ of minimum degree and one of $v_{j,1}, \dots, v_{j,\ell}$ with minimum degree. By adding edges one by one in this way, we ensure that the maximum degree of the vertices of S_u is at most $\frac{k}{\ell} + 1$.

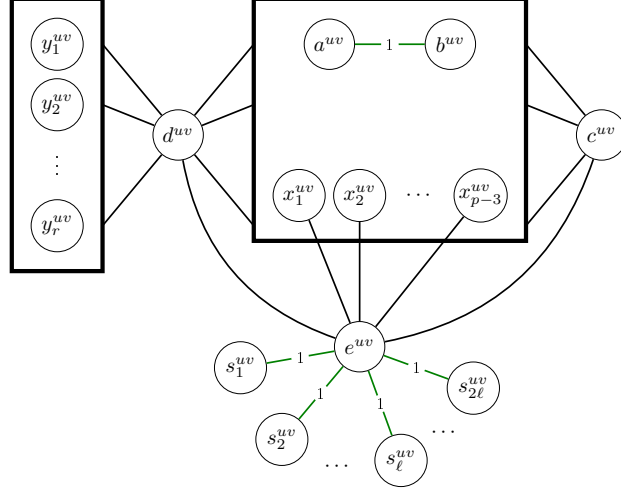

Figure 5: The edge gadget E_{uv} when $r > 0$. The vertices inside each of the two rectangles form a clique. The vertex c^{uv} is adjacent to every vertex inside the largest rectangle. The vertex d^{uv} is adjacent to every vertex inside the two rectangles.

Finally, for each edge uv of G , we identify the 2ℓ vertices $s_1^{uv}, \dots, s_{2\ell}^{uv}$ with the ℓ vertices of S_u corresponding to v (since v is a neighbour of u , by the construction of S_u in the previous paragraph, there are ℓ such vertices in S_u) and with the ℓ vertices of S_v corresponding to u . This creates the graph G' . Note that its maximum degree is $\max(2\ell + p - 1, \frac{k}{\ell} + 2) \leq 5p \leq 5\sqrt{3k}$.

Claim 10 *For any injective k -edge-coloring γ of E_{uv} , we have $\gamma(e^{uv} s_1^{uv}) = \gamma(e^{uv} s_2^{uv}) = \dots = \gamma(e^{uv} s_{2\ell}^{uv})$. Moreover if γ is a partial injective k -edge-coloring of E_{uv} where $\gamma(e^{uv} s_1^{uv}) = \gamma(e^{uv} s_2^{uv}) = \dots = \gamma(e^{uv} s_{2\ell}^{uv})$ and there are no other colored edges, we can extend γ to E_{uv} .*

Proof. First note that the clique $\{x_1^{uv}, \dots, x_{p-3}^{uv}, a^{uv}, b^{uv}, c^{uv}\}$ needs exactly $\binom{p}{2}$ distinct colors. W.l.o.g. $a^{uv}b^{uv}$ is colored 1 and the colors used for this clique are $1, 2, \dots, \binom{p}{2}$. None of these colors can be used to color the r edges of the form $d^{uv}y_j^{uv}$ hence they must be colored with $\binom{p}{2} + 1, \dots, \binom{p}{2} + r$. One can observe that an edge $e^{uv}s_i^{uv}$ cannot have a color among $\binom{p}{2} + 1, \dots, \binom{p}{2} + r$ as it is at distance 2 from the edges of the form $d^{uv}y_j^{uv}$ ($j \in \{1, \dots, r\}$). Moreover this edge cannot receive the same color as one of the edges of the clique $\{x_1^{uv}, \dots, x_{p-3}^{uv}, a^{uv}, b^{uv}, c^{uv}\}$ except for the color 1 on the edge $a^{uv}b^{uv}$. Hence all edges of the form $e^{uv}s_i^{uv}$ have the same color.

Now suppose we have a coloring γ such that these edges $e^{uv}s_i^{uv}$ ($i \in \{1, \dots, 2\ell\}$) are all colored with the same color, say 1. We color $a^{uv}b^{uv}$ with color 1 and use the $\binom{p}{2} + r - 1$ other colors to color the rest of the edges of the clique $\{x_1^{uv}, \dots, x_{p-3}^{uv}, a^{uv}, b^{uv}, c^{uv}\}$ and the edges of the form $d^{uv}y_j^{uv}$ ($j \in \{1, \dots, r\}$). We color $e^{uv}z$ for $z \in \{x_1^{uv}, \dots, x_{p-3}^{uv}, c^{uv}\}$ with the color of $a^{uv}z$.

If $r = 0$, then E_{uv} is colored and γ is an injective k -edge-coloring.

If $r > 0$, we color $d^{uv}e^{uv}$ and $d^{uv}a^{uv}$ with the color of $d^{uv}y_1^{uv}$. We color $d^{uv}z$ for $z \in \{x_1^{uv}, \dots, x_{p-3}^{uv}, b^{uv}\}$ with the color of $c^{uv}z$. It is left to color the edges of the clique $\{y_1^{uv}, \dots, y_r^{uv}\}$, for which we have available the $\binom{p-1}{2}$ colors used to color the clique $\{x_1^{uv}, \dots, x_{p-3}^{uv}, a^{uv}, b^{uv}\}$, which is enough as $r \leq p - 1$. This is an injective k -edge coloring of E_{uv} . \blacksquare

Suppose there is an injective k -edge-coloring γ of G' . For an edge uv of G , we color it with the color $\gamma(e^{uv}s_1^{uv})$. Take two adjacent edges of G : uv_1 and uv_2 . In S_u , there is an edge between $v_{1,i}$ and $v_{2,j}$ for some indices i and j . Thus the edges $e^{uv_1}v_{1,i}$ and $e^{uv_2}v_{2,j}$ receive different colors. By Claim 10, uv_1 and uv_2 receive different colors. Hence G admits a k -edge-coloring.

Suppose there is a k -edge coloring γ of G . For each edge uv , we color $e^{uv}s_i^{uv}$ with the color $\gamma(uv)$. By Claim 10, we can extend this coloring to all E_{uv} . At this point there is no conflict between the colored edges. Indeed the only pairs of edges which are at distance 2 and not in the same edge gadget are of the form $e^{uv}s_i^{uv}$, and since γ is proper, there is no conflict here. It is left to color the edges inside the vertex gadget. Let $e = v_{i,j}v_{i',j'}$ be an uncolored edge. As the maximum degree of the vertices of S_u is at most $\frac{k}{\ell} + 2$, there are at most $(\frac{k}{\ell} + 2)^2$ edges incident to a vertex of S_u that can be in conflict with e . We must also consider the edges incident with e^{uv_i} and e^{uv_j} . For each of the two vertices there is

one forbidden color $\gamma(uv_i)$ which is common to 2ℓ edges incident to e^{uv_i} to which we need to add $p - 1$ colors for the other edges of e^{uv_i} . In the end, there are at most $2p + (\frac{k}{\ell} + 2)^2$ forbidden colors for e . As $2p + (\frac{k}{\ell} + 2)^2 \leq 2p + (\frac{p-1}{4} + 2)^2 = (\frac{p-1}{4})^2 + 3p + 3 \leq k$ when $k \geq 45$ and $p \geq 10$, G' admits an injective k -edge-coloring. \square

7 Conclusion

We proved that INJECTIVE 3-EDGE-COLORING and INJECTIVE 4-EDGE-COLORING are NP-complete on some restricted classes of subcubic graphs. One can ask whether INJECTIVE 5-EDGE-COLORING is NP-complete on subcubic graphs. A conjecture proposed by Ferdjallah *et al.* [7] states that every subcubic graph admits an injective 6-edge-coloring (it is proved for planar graphs in [14]). In fact, we only know of two connected subcubic graphs which require six colors: K_4 and the prism. Perhaps these are the only examples that are not 5-colorable, in which case INJECTIVE 5-EDGE-COLORING would be polynomial-time solvable for this class.

We have also proved that for planar bipartite subcubic graphs, INJECTIVE 3-EDGE-COLORING is polynomial-time solvable when the girth is at least 16 (because the answer is always YES), but NP-Complete when the girth is 6. It would be interesting to determine the values of the girth of planar bipartite subcubic graphs for which INJECTIVE 3-EDGE-COLORING stays NP-Complete, becomes polynomial-time solvable, and always has YES as an answer.

We also do not know whether INJECTIVE 4-EDGE-COLORING is NP-Complete for bipartite subcubic graphs.

8 Acknowledgments

This research was supported by the IFCAM project “Applications of graph homomorphisms” (MA/IFCAM/18/39) and by the ANR project HOSIGRA (ANR-17-CE40-0022).

References

- [1] Maria Axenovich, Philip Dörr, Jonathan Rollin, and Torsten Ueckerdt. Induced and weak induced arboricities. *Discrete Mathematics*, 342(2):511–519, 2019.
- [2] Oleg V. Borodin, Aleksey N. Glebov, André Raspaud, and Mohammad R. Salavatipour. Planar graphs without cycles of length from 4 to 7 are 3-colorable. *Journal of Combinatorial Theory, Series B*, 93(2):303–311, 2005.
- [3] Yuehua Bu and Chentao Qi. Injective edge coloring of sparse graphs. *Discrete Mathematics, Algorithms and Applications*, 10(02):1850022, 2018.
- [4] Domingos M. Cardoso, J. Orestes Cerdeira, J. Pedro Cruz, and Charles Dominic. Injective edge coloring of graphs. *Filomat*, 33:6411–6423, 2019.
- [5] Richard Cole and Lukasz Kowalik. New linear-time algorithms for edge-coloring planar graphs. *Algorithmica*, 50(3):351–368, 2008.
- [6] Paul Erdős. Problems and results in combinatorial analysis and graph theory. In J. Akiyama, Y. Egawa, and H. Enomoto, editors, *Graph Theory and Applications*, volume 38 of *Annals of Discrete Mathematics*, pages 81–92. Elsevier, 1988.
- [7] Baya Ferdjallah, Samia Kerdjoudj, and André Raspaud. Injective edge-coloring of sparse graphs, 2019. Manuscript, arXiv e-print: 1907.09838.
- [8] Jean-Luc Fouquet and Jean-Loup Jolivet. Strong edge-coloring of graphs and applications to multi- k -gons. *Ars Combinatoria*, 16A:141–150, 1983.
- [9] Michael R. Garey, David S. Johnson, and Larry Stockmeyer. Some simplified NP-complete graph problems. *Theoretical Computer Science*, 1(3):237–267, 1976.

- [10] Geňa Hahn, Jan Kratochvíl, Josef Širáň, and Dominique Sotteau. On the injective chromatic number of graphs. *Discrete Mathematics*, 256(1):179–192, 2002.
- [11] Hervé Hocquard, Pascal Ochem, and Petru Valicov. Strong edge-colouring and induced matchings. *Information Processing Letters*, 113(19):836–843, 2013.
- [12] Ian Holyer. The NP-completeness of edge-coloring. *SIAM Journal on Computing*, 10(4):718–720, 1981.
- [13] Ton Kloks. *Treewidth, Computations and Approximations*. Springer, 1994.
- [14] Alexandr V. Kostochka, André Raspaud, and Jingwei Xu. Injective edge coloring of graphs with given maximum degree, 2020. Manuscript, arXiv e-print: 2010.00429.
- [15] Daniel Leven and Zvi Galil. NP completeness of finding the chromatic index of regular graphs. *Journal of Algorithms*, 4(1):35–44, 1983.
- [16] Jun Yue, Shiliang Zhang, and Xia Zhang. Note on the perfect EIC-graphs. *Applied Mathematics and Computation*, 289:481 – 485, 2016.