



HAL
open science

Induced betweenness in order-theoretic trees

Bruno Courcelle

► **To cite this version:**

| Bruno Courcelle. Induced betweenness in order-theoretic trees. 2021. hal-03175157v3

HAL Id: hal-03175157

<https://hal.science/hal-03175157v3>

Preprint submitted on 23 Jul 2021 (v3), last revised 7 Sep 2022 (v5)

HAL is a multi-disciplinary open access archive for the deposit and dissemination of scientific research documents, whether they are published or not. The documents may come from teaching and research institutions in France or abroad, or from public or private research centers.

L'archive ouverte pluridisciplinaire **HAL**, est destinée au dépôt et à la diffusion de documents scientifiques de niveau recherche, publiés ou non, émanant des établissements d'enseignement et de recherche français ou étrangers, des laboratoires publics ou privés.

Induced betweenness in order-theoretic trees

Bruno Courcelle
LaBRI, CNRS, Bordeaux University
courcell@labri.fr

July 23, 2021

Abstract : The ternary relation $B(x, y, z)$ of *betweenness* states that an element y is between the elements x and z , in some sense depending on the considered structure. In a partially ordered set (N, \leq) , $B(x, y, z) :\iff x < y < z \vee z < y < x$, and the corresponding *betweenness structure* is (N, B) . The class of betweenness structures of linear orders is *first-order definable*. That of partial orders is *monadic second-order definable*.

An *order-theoretic tree* is a partial order such that the set of elements larger than any element is linearly ordered and any two elements have an upper-bound. Finite or infinite rooted trees ordered by the ancestor relation are order-theoretic trees. In an order-theoretic tree, $B(x, y, z)$ means that $x < y < z$ or $z < y < x$ or $x < y \leq x \sqcup z$ or $z < y \leq x \sqcup z$, where $x \sqcup z$ is the least upper-bound of incomparable elements x and z . In a previous article, we established that the corresponding class of betweenness structures is monadic second-order definable.

We prove here that the *induced substructures* of the betweenness structures of the countable order-theoretic trees form a monadic second-order definable class, denoted by **IBO**. The proof uses a variant of cographs, the *partitioned probe cographs*, and their known six finite minimal excluded induced subgraphs called the *bounds* of the class. This proof links two apparently unrelated topics: cographs and order-theoretic trees.

However, the class **IBO** has finitely many bounds, *i.e.*, minimal excluded finite induced substructures. Hence it is first-order definable. The proof of finiteness uses well-quasi-orders and does not provide the finite list of bounds. Hence, the associated first-order defining sentence is not known.

Introduction

The ternary relation $B(x, y, z)$ of *betweenness* expresses that y is between x and z in a sense depending on the considered structure, typically a tree, a

graph or a partial order. The corresponding *betweenness structure* is (N, B) where N is the set of nodes, of vertices or of elements. The class of betweenness structures of linear orders is *first-order definable*, *i.e.*, is axiomatized by a single first-order sentence; that of partial orders is *monadic second-order* definable, see [8, 10, 17]. The betweenness structures of certain finite graphs have been studied in [1, 2] and for trees of various kinds, in [4, 6, 7].

An *order-theoretic forest* (an *O-forest* in short) is a partial order $T = (N, \leq)$ such that $\{x \in N \mid x \geq y\}$ is linearly ordered for any y , a notion studied by Fraïssé [13] (under the name of *tree*). It is an *order-theoretic tree* (an *O-tree* in short) if any two elements have an upper-bound. A finite O-tree is a rooted tree ordered by the ancestor relation. The ordered set of rational numbers is an O-tree although no node has an immediate ancestor. Previously, we have used O-trees to define the modular decomposition and the rank-width of a countable graph [4, 9].

The *betweenness structure* of an O-forest $T = (N, \leq)$ is (N, B_T) such that

$$B_T(x, y, z) : \iff x \neq y \neq z \neq x \wedge [(x < y \leq x \sqcup z) \vee (z < y \leq x \sqcup z)]$$

where $x \sqcup z$ denotes the least upper-bound of x and z . If $x \sqcup z$ does not exist, there is no triple (x, y, z) in B_T . An *induced betweenness* is a induced substructure of such (N, B_T) where T can be, equivalently, an O-tree.

In [4, 7] we have axiomatized several types of betweenness structures, in particular those of O-trees by *monadic second-order sentences*. We conjectured that the class **IBO** of *induced* betweenness structures in O-trees is monadic second-order definable too. In the present article, we prove a slight weakening of this conjecture by allowing the defining monadic second-order sentence to use the finiteness set predicate $Fin(X)$, expressing that the set X is finite. However, as we explain below, this class is first-order definable but the proof does not construct the defining sentence.

Our proof of monadic second-order definability uses the fact that the *partitioned probe cographs* have exactly six known bounds [16]. A *bound* is a minimal induced subgraph that is not in a considered *hereditary* class, *i.e.*, a class of graphs closed under taking induced subgraphs (see Pouzet [18]). A *probe cograph* is obtained from a cograph by choosing a subset L of its vertex set and removing the edges whose two ends are in L . In a partitioned probe cograph, we keep track of L by labelling its vertices. A *probe cograph* is obtained from a partitioned probe cograph by forgetting such labels. The path P_5 is a probe cograph. The path P_6 is a bound for probe cographs. We exhibit a few others, without proving that the list is complete.

The class of probe cographs is hereditary. As it is *2-well-quasi-ordered* [11, 18], it has finitely many bounds. They are not completely known but we define an algorithm, based on monadic second-order logic and clique-width *terms* (hence, on decompositions of the graphs as tree-like unions of complete bipartite graphs) that *could* compute them. Unfortunately, this algorithm is intractable.

We link two apparently unrelated notions: betweenness in O-trees and a variant of cographs. To give an intuition about this link, we observe that the

cocomparability graph of an O-tree is a graph without induced P_4 , hence, is a (possibly infinite) cograph (Proposition 3.5).

However, the class **IBO** has finitely many *bounds*, *i.e.*, minimal excluded induced finite substructures, hence is first-order definable. We use a result by Pouzet [18] to prove this fact. This proof uses well-quasi-orders of labelled ternary structures, and does not provide the finite list of bounds. Hence, the associated first-order defining sentence is not known. We have no algorithm, even intractable (as for probe cographs), to determine the bounds of **IBO**. We explain this fact by exhibiting a property of clique-width that does not extend from graphs to ternary structures, as we would need.

Summary: Section 1 reviews partial orders, graphs, clique-width, (usual) trees and logic. Section 2 defines and studies probe cographs. Section 3 defines order-theoretic trees. Section 4 proves the two logical characterizations of **IBO**. Section 5 examines the bounds of the class of probe cographs. Section 6 states and discusses three open problems.

Acknowledgement: I thank Maurice Pouzet for fruitful email exchanges, from which I obtained the FO-definability of the class **IBO**, by a proof based on one of his works.

1 Definitions and notation

All graphs, trees, partial orders and, more generally, relational structures are *countable*, which means finite or countably infinite. We denote by $[k]$ the set $\{1, \dots, k\}$. In some cases, we denote by $A \uplus B$ the union of two sets A and B to stress that they are disjoint.

Partial orders

For a partial order \leq, \subseteq , we denote respectively by $<, \subset$, the corresponding strict partial order. We write $x \perp y$ if x and y are incomparable for the considered order.

Let $P = (V, \leq)$ be a partial order. For $X, Y \subseteq V$, the notation $X < Y$ means that $x < y$ for every $x \in X$ and $y \in Y$. We write $X < y$ instead of $X < \{y\}$ and similarly for $x < Y$. We use a similar notation for \leq and \perp . The least upper-bound of x and y is denoted by $x \sqcup y$ if it exists and is then called their *join*.

If $X \subseteq V$, then we define $N_{<}(X) := \{y \in V \mid y \leq X\}$ and similarly for $N_{<}$. We have $N_{<}(X) \leq X$ and $N_{<}(\emptyset) = V$. We define $L_{>}(X) := \{y \in V \mid y \geq X\}$, and similarly $L_{>}(X)$. We write $L_{\geq}(x)$ (resp. $L_{\geq}(x, y)$) if $X = \{x\}$ (resp. $X = \{x, y\}$) and similarly for $L_{>}$.

An *embedding* of a partial order $P = (N, \leq)$ into another one $P' = (N', \leq')$ is an injective mapping $j : N \rightarrow N'$ such that $j(x) \leq' j(y)$ if and only if $x \leq y$. It is a *join-embedding* if $j(x) \sqcup' j(y) = j(x \sqcup y)$ whenever x and y have a join in P . We write $P \subseteq_j P'$ if $N \subseteq N'$ and the inclusion mapping is a join-embedding. If P and P' are labelled, then the labels are preserved in embeddings.

Graphs

Graphs are undirected and simple, which means without loops and parallel (multiple) edges. We denote respectively by P_n, C_n, K_n a path, a cycle and a clique with n vertices.

The notation $u - v$ designates an edge with ends u and v . As a property, it means also "there is an edge between u and v ". We say then that u and v are *adjacent* or *are neighbours*. The notation $u - v - w - x$ shows the vertices and edges of a path of 4 vertices. The notation $u - v - w - x - u$ shows the vertices and edges of a 4-cycle.

Induced subgraph inclusion is denoted by \subseteq_i and $G[X]$ is the induced subgraph of $G = (V, E)$ with vertex set X . Then, $G - x := G[V - \{x\}]$.

We denote by $G \oplus H$ the union of disjoint graphs G and H . This operation does not modify the possibly existing labels. Then, $G \otimes H$ is $G \oplus H$ augmented with edges between any vertex of G and any vertex of H .

The *diameter* of a connected graph is the maximal *distance* between two vertices, *i.e.*, the minimum number of edges of a path between them.

By a *class* of graphs, we mean a set closed under isomorphism.

Rooted trees

A *tree* is a connected graph without cycles. It is convenient to call *nodes* the vertices of a tree. A *rooted tree* is a triple $T = (N_T, E_T, r)$ such that (N_T, E_T) is a tree and $r \in N$. It can be defined as the partial order (N_T, \leq_T) such that $x \leq_T y$ if and only if y is on the path from the *root* r to x . A *leaf* is a minimal node and L_T denotes the set of leaves. The other nodes are *internal*. We will always handle a rooted tree T as a partial order (N_T, \leq_T) . In Section 3, we will define generalized trees, called *O-trees*, as partial orders, as done by Fraïssé [13].

A node x is a *son* of y if $x <_T y$ and there is no node z such that $x <_T z <_T y$. The *degree* of a node is the number of its sons. A node of degree 0 is thus a leaf.

The *subtree* of a rooted tree T issued from a node u is $T/u := (N_{T \leq}(u), \leq)$ where \leq is the restriction of \leq_T to $N_{T \leq}(u)$.

A *rooted forest* F is the union of pairwise disjoint rooted trees and Rt_F denotes the set of roots of its trees.

A finite rooted tree T can be denoted linearly by \tilde{T} defined as follows:

If T is reduced to r , then $\tilde{T} := r$.

If T has root r and subtrees T_1, \dots, T_p issued from the sons of the root, then $\tilde{T} := r(\tilde{T}_1, \dots, \tilde{T}_p)$.

The order of the sequence T_1, \dots, T_p is irrelevant as trees are only ordered by the ancestor relation. In some cases, we can replace in this notation a node by its label.

Relational structures and logic

A *relational structure* is a tuple $S = (D, R_1, \dots, R_p)$ where D is a set, its *domain* and R_1, \dots, R_p are (finitely many) relations of fixed arity. The *signature* of S is \mathcal{R} defined as the p -tuple of arities of R_1, \dots, R_p . We will consider classes of

structures having a fixed signature \mathcal{R} . If S is a relational structure with domain N and $X \subseteq N$, then $S[X]$ denotes the induced substructure with domain X , and \subseteq_i denotes an induced inclusion of relational structures of same signature.

We will use the following structures : (N, \leq) to describe a partial order, a rooted tree or an order-theoretic tree (defined in Section 3), (V, edg) to describe an undirected graph with set V of vertices where $\text{edg}(x, y)$ means that there is an edge between x and y . Betweenness structures are of the form (N, B) where B is a ternary relation. Vertex or node labellings are formalized by additional unary relations.

The isomorphism of relational structures is denoted by \simeq . The isomorphism class of a structure S is denoted by $[S]_{\simeq}$. A set of structures is called a *class* if it is closed under isomorphism. We say that it is *finite* if the set of its isomorphism classes is finite. A class \mathcal{C} is *hereditary* if it is closed under taking induced substructures.

Properties of structures (and of graphs) will be expressed by *first-order (FO)* or *monadic-second order (MSO)* sentences. A *sentence* is a formula without free variables. For an example, that a graph has no induced subgraph isomorphic to a finite graph H is FO expressible. That a graph is not connected is expressed in its representing structure (V, edg) by the following MSO sentence:

$$\exists X[(\exists x.x \in X) \wedge (\exists y.y \notin X) \wedge (\forall x, y.(x \in X \wedge y \notin X \implies \neg \text{edg}(x, y))].$$

The book [10] contains a detailed study of monadic second-order logic.

We consider classes of finite or countably infinite structures. Such a class is *MSO (or FO)-definable* if it is the class of finite or countably infinite models of an MSO (or FO) sentence. It is *uFO-definable*, if it is FO-definable by a *universal sentence*, *i.e.*, of the form $\forall x, y, z \dots \varphi(x, y, z, \dots)$ where $\varphi(x, y, z, \dots)$ is quantifier-free.

The *finiteness set predicate* $\text{Fin}(X)$ expresses that a set X is finite. The finiteness of a set $X \subseteq N$ is not MSO expressible, unless some linear order on N can be defined by MSO formulas (see Example 1.6 in [7]). This is the case for example if N is the set of nodes of a tree of bounded degree. An MSO_{fin} -sentence is an MSO-sentence where $\text{Fin}(X)$ can be used.

A class of structures \mathcal{C} is *finitary* if a structure S is in \mathcal{C} if and only if its finite induced substructures are all in \mathcal{C} . This implies that it is hereditary, but not conversely: consider the disjoint unions of linear orders whose intervals $[x, y]$ are finite.

Let \mathcal{C} be finitary. Its *bounds*, forming the class $\text{Bnd}(\mathcal{C})$, are the finite structures not in \mathcal{C} whose proper induced substructures are all in \mathcal{C} . Then \mathcal{C} is the class of structures having no induced substructure isomorphic to one in $\text{Bnd}(\mathcal{C})$.

A routine proof can establish the following.

Proposition 1.1 : A class of structures is uFO-definable if and only if it is finitary and has a finite set (or class) of bounds. If it is so, its finite structures can be recognized in polynomial time. \square

These definitions and proposition apply to graphs (defined as above) represented by structures (V, edg) .

A class of graphs may be finitary and have infinitely many bounds : for an example, the induced subgraphs of the cycles C_n , $n \geq 3$. This class is finitary but the disjoint union of any two cycles is a bound.

2 Cographs and related notions

In this section all graphs and trees are finite.

Definition 2.1 : Cographs

(a) A graph is a *cograph* if and only if it can be generated from isolated vertices by the operations \oplus and \otimes , if and only if it has no induced path P_4 . There are many other characterizations [19]. The family of cographs is hereditary. Its only bound is P_4 .

(b) The cycle $a - b - c - d - a$ is defined by the term $(a \oplus c) \otimes (b \oplus d)$. To define it up to isomorphism, that is, without naming the vertices, we will use the term $(\bullet \oplus \bullet) \otimes (\bullet \oplus \bullet)$. We can use the notation $t_1 \oplus t_2 \oplus \dots \oplus t_n$ because the operation \oplus is associative, and similarly for \otimes . We can also use the notation $\oplus(t_1, t_2, \dots, t_n)$ or $\otimes(t_1, t_2, \dots, t_n)$ if we consider t as a rooted tree whose internal vertices are labelled by \oplus or \otimes .

(c) The syntactic tree of a term defining a cograph $G = (V, E)$ is called a $\{\oplus, \otimes\}$ -tree. It is a rooted tree whose set of leaves is V and whose internal nodes are of degree at least 2 and labelled by \oplus or \otimes .

Definition 2.2 : 2-graphs

A *2-graph* is a graph (V, E) equipped with a bipartition $V_1 \uplus V_2$ of its vertex set V . We will say that $x \in V_i$ is an *i-vertex*. The *type* of a finite path $x_1 - x_2 - \dots - x_n$ in a 2-graph is the word $b_1 b_2 \dots b_n$ over $\{1, 2\}$ such that, for each i , x_i is a b_i -vertex. \square

Definitions 2.3 : Probe cographs

(a) A *partitioned probe cograph* (a *pp-cograph* in short) is a 2-graph obtained from a cograph (V, E) by choosing a bipartition $V_1 \uplus V_2$ of V and removing the edges between its 1-vertices.

(b) A *probe cograph* (a *p-cograph* in short) is obtained from a pp-cograph by forgetting the bipartition (and the corresponding labelling of its vertices by 1 or 2).

(c) A bipartition of a graph (or a vertex-labelling by 1 or 2) is *good* if it makes it into a pp-cograph.

(d) Partitioned probe cographs can be defined by terms, similar to those that define cographs, using the operation \oplus and the operation \otimes that we redefine as follows for 2-graphs: $G \otimes H$ is $G \oplus H$ augmented with all edges between an i -vertex of G and a j -vertex of H , provided i and j are not both 1. It is associative. A nullary symbol $\bullet_i(x)$ defines x as an isolated i -vertex. \square

The path $P_4 = a - b - c - d$ with labelling of type 1212 is a pp-cograph defined by the term $\bullet_1(c) \otimes ([\bullet_1(a) \otimes \bullet_2(b)] \oplus \bullet_2(d))$. To define it up to isomorphism, we

can use the term $\bullet_1 \otimes ([\bullet_1 \otimes \bullet_2] \oplus \bullet_2)$. Note that $\bullet_1(x) \otimes \bullet_1(y)$ and $\bullet_1(x) \oplus \bullet_1(y)$ define the same 2-graph. See also Example 2.5(1). \square

We review some results from [11, 16].

Proposition 2.4 : (1) The class of partitioned probe cographs is hereditary. Its bounds are the paths of types 11, 2222, 1222, 2122 or 21212 and the 2-graph Q defined as the path $a - b - c - d - e$ of type 12221 augmented with the edge $b - d$. Its graphs can be recognized in linear time.

(2) The class of probe cographs is hereditary and has finitely many bounds. Its graphs can be recognized in linear time.

An immediate consequence of interest for the present article is that pp-cographs are uFO-definable among 2-graphs. The defining sentence is effectively constructed from the six *known* bounds. Probe cographs are so, but the corresponding uFO sentence is not known, because the complete list of bounds is not either. However, their bounds are definable in monadic second-order (MSO) logic by a known sentence, obtained from the FO sentence that defines the pp-cographs. We will discuss these points in Section 5.

Examples 2.5: (1) The path P_4 is not a cograph. It has good labellings of types 1212 and 1221. Its labellings of type 1222, 2122 and 2222 are not good.

(2) The labelled path $P_5 = a - b - c - d - e$ of type 12121 is a pp-cograph defined by the term $\bullet_1(c) \otimes [(\bullet_1(a) \otimes \bullet_2(b)) \oplus (\bullet_1(e) \otimes \bullet_2(d))]$. No other labelling of it is good, which follows from Proposition 2.4(1).

(3) The path $P_6 = a - b - c - d - e - f$ is not a p-cograph. Assume it has a good labelling. The induced path $a - b - c - d - e$ must have type 12121 and f must have label 2. But then $b - c - d - e - f$ has type 21212, which is not possible by (1). It follows that a p-cograph has no induced P_6 . Hence, a connected p-cograph cannot have diameter 5 or more because otherwise, it would contain an induced path P_6 . Furthermore, P_6 is a bound of p-cographs.

(4) A similar proof using (1) shows that the cycle C_5 is a bound of p-cographs. All other graphs having at most 5 vertices are p-cographs. Proposition 5.5 will present some bounds for p-cographs. \square

3 Order-theoretic trees

Definition 3.1: (a) An *order-theoretic forest* (an *O-forest* in short) is a partial order $J = (N, \leq)$ such that, for each $x \in N$, the set $L_{\geq}(x) := \{y \mid y \geq x\}$ is linearly ordered. An O-forest is an *O-tree* if every two nodes have an upper-bound. An O-tree is a *join-tree* if every two elements x and y have a least upper-bound, denoted by $x \sqcup y$ and also called their *join*. An O-tree may have no largest node. Its largest node if it exists is called the *root*. If $x \sqcup y$ and $y \sqcup z$ are defined, then so is $x \sqcup z$ and it belongs to $\{x \sqcup y, y \sqcup z\}$.

(b) If $u < w$, then we say that w is an *ancestor* of u .

(c) A *line* in an O-forest (N, \leq) is a subset L of N that is linearly ordered and *convex*, i.e., is such that $z \in L$ if $x, y \in L$ and $x < z < y$.

(d) A *leaf* is a minimal node. It has *degree* 0; the set of leaves is denoted by L_J .

(e) A node x has *degree* 1 if there is $y < x$ such that every node $z < x$ is comparable with y . For finite forests, this is equivalent to the definition in Section 1. If we delete some nodes of degree 1 of an O-forest J , we obtain a (possibly empty) O-forest J' such that $J' \subseteq_j J$ because a node of degree 1 is not the join of any two incomparable nodes. \square

Definition 3.2 : *Substitutions of lines in O-forests.*

Let $J = (N, \leq)$ be an O-forest and, for each $x \in N$, let (A_x, \leq_x) be a (possibly empty or singleton) linearly ordered set. These sets are assumed to be pairwise disjoint. We let $J' = J[A_x/x; x \in N] := (N', \leq')$ be the partial order such that :

N' is the union of the sets A_x ,

$u \leq' v$ if and only if either $u \leq_x v$, or $u \in A_x, v \in A_y$ and $x < y$.

It is an O-forest in which each nonempty A_x is a line.

Definitions 3.3 : *The join-completion of an O-forest.*

Let $J = (N, \leq)$ be an O-forest and \mathcal{K} be the set of upwards closed lines $L_{\geq}(x, y) := L_{\geq}(x) \cap L_{\geq}(y)$ for all (possibly equal) nodes x, y . If x and y have a join, then $L_{\geq}(x, y) = L_{\geq}(x \sqcup y)$. If they have no upper-bound, then $L_{\geq}(x, y)$ is empty.

The family \mathcal{K} is countable. We let $h : N \rightarrow \mathcal{K}$ map x to $L_{\geq}(x)$ and $\widehat{J} := (\mathcal{K}, \supseteq)$. We call \widehat{J} the *join-completion* of J because of the following proposition, stated with these hypotheses and notation.

Proposition 3.4 [7] : The partially ordered set $\widehat{J} := (\mathcal{K}, \supseteq)$ is a join-tree and h is a join-embedding $J \rightarrow \widehat{J}$. \square

If we identify $x \in N$ with $h(x) := L_{\geq}(x)$, we have a join-preserving inclusion $J \subseteq_j \widehat{J}$. The join of $h(x)$ and $h(y)$ is $L_{\geq}(x, y)$.

The following side proposition shows that cographs arise naturally from O-forests. We recall that \perp denotes incomparability.

Proposition 3.5: The cocomparability graph $CC(J) := (N, \perp)$ of a finite rooted forest $J = (N, \leq)$ is a cograph.

Proof sketch: First we prove that the cocomparability graph $CC(T) = (N, \perp)$ of a finite rooted tree $T = (N, \leq)$ is a cograph. If $T = a(T_1, \dots, T_n)$ and $n \geq 2$, then $CC(T) = a \oplus (CC(T_1) \otimes \dots \otimes CC(T_n))$. If $n = 1$, we have $CC(T) = a \oplus CC(T_1)$.

If J is a forest that is the disjoint union of rooted trees T_1, \dots, T_p , then $CC(J) = CC(T_1) \otimes \dots \otimes CC(T_p)$. \square

If we define as a cograph any finite or infinite graph without induced path P_4 , then this proposition extends to countable O-forests.

4 Betweenness in order-theoretic trees

We will consider ternary structures $S = (N, B)$. If $n > 2$, the notation $\neq(x_1, x_2, \dots, x_n)$ means that x_1, x_2, \dots, x_n are pairwise distinct, hence it abbreviates an FO formula. If $n > 3$, then $B^+(x_1, x_2, \dots, x_n)$ abbreviates the FO formula

$$B(x_1, x_2, x_3) \wedge B(x_2, x_3, x_4) \wedge \dots \wedge B(x_{n-2}, x_{n-1}, x_n)$$

and $A(x_1, x_2, x_3)$ abbreviates

$$B(x_1, x_2, x_3) \vee B(x_2, x_1, x_3) \vee B(x_1, x_3, x_2).$$

Definitions and background 4.1 : *O-forests and their betweenness relations.*

(a) The *betweenness relation* of an O-forest $J = (N, \leq)$ is the ternary relation $B_J \subseteq N^3$ such that :

$$B_J(x, y, z) : \iff \neq(x, y, z) \wedge ([x < y \leq x \sqcup z] \vee [z < y \leq x \sqcup z]).$$

If $x \sqcup z$ is undefined, then $B_J(x, y, z)$ holds for no triple (x, y, z) . If $x < y < z$, we have $B_J(x, y, z)$.

We denote by **BO** the class of betweenness structures (N, B_J) of O-forests $J = (N, \leq)$.

(b) The following related classes have been considered in [6, 7].

IBO is the class of induced substructures of the structures in **BO**.

QT (for *quasi-trees*) is the class of betweenness structures of join-trees.

IBQT is the class of induced substructures of structures in **QT**.

We have the following proper inclusions :

$$\mathbf{QT} \subset \mathbf{IBQT} \cap \mathbf{BO},$$

$$\mathbf{IBQT} \subset \mathbf{IBO} \text{ and}$$

$$\mathbf{BO} \subset \mathbf{IBO}.$$

The classes **IBQT** and **BO** are incomparable, and for finite structures, we have **QT** = **BO**.

(c) The betweenness relation B of a rooted tree $T = (N, \leq)$, (hence, $(N, B) \in \mathbf{QT}$) satisfies the following properties for all $x, y, z, u \in N$:

- A1 : $B(x, y, z) \Rightarrow \neq(x, y, z)$.
A2 : $B(x, y, z) \Rightarrow B(z, y, x)$.
A3 : $B(x, y, z) \Rightarrow \neg B(x, z, y)$.
A4 : $B(x, y, z) \wedge B(y, z, u) \Rightarrow B^+(x, y, z, u)$.
A5 : $B(x, y, z) \wedge B(x, u, y) \Rightarrow B^+(x, u, y, z)$.
A6 : $B(x, y, z) \wedge B(x, u, z) \Rightarrow y = u \vee B^+(x, u, y, z) \vee B^+(x, y, u, z)$.
A7 : $\neq(x, y, z) \Rightarrow A(x, y, z) \vee \exists w [B(x, w, y) \wedge B(y, w, z) \wedge B(x, w, z)]$.

Conversely, every ternary structure satisfying these properties is in **QT** [4]. Hence, **QT** is FO-definable. This class is not hereditary. Its closure under taking induced substructures, the class **IBQT**, is uFO-definable by Proposition 2.12 of [7] and defined by A1-A6 together with :

$$A8 : \forall u, x, y, z [\neq(u, x, y, z) \wedge B(x, y, z) \wedge \neg A(u, y, z) \Rightarrow B(x, y, u)].$$

The class **BO** is MSO definable [6, 7]. The case of **IBO** was left as a conjecture. We will prove the following two results.

- Theorem 4.2** : (1) The class **IBO** is effectively MSO_{fin}-definable.
(2) This class is uFO-definable.

Assertion (2) is not effective: we do not know the defining sentence. Assertion (1) entails that the class of bounds of **IBO** is MSO-definable (among finite structures). It is finite, but this knowledge is not sufficient to yield an algorithm.

We will consider ternary structures (N, B) that always satisfy the uFO-expressible properties A1-A6. These properties hold in every structure in **IBO** but do not characterize this class (Proposition 3.22 of [7]).

4.1 Preliminary results on IBO

Defintion 4.3 : The *Gaifman graph* of a ternary structure $S = (N, B)$ is the graph $Gf(S)$ whose vertex set is N and that has an edge $u - v$ if and only if u and v belong to some triple in B . We say that S is *connected* if $Gf(S)$ is. If it is not, then S is the disjoint union of the induced structures $S[X]$ for all connected components $X \subseteq N$ of $Gf(S)$.

Lemma 4.4: (1) A structure S is in **IBO** if and only if its connected components are.

(2) If a structure S in **IBO** is connected, then it is an induced betweenness structure of an O-tree.

Proof: (1) The "only if" direction is clear by the definitions. Conversely, assume that each connected component of a ternary structure $S = (N, B)$ is in **IBO**. For each of them $S[X]$, let $U_X := (M_X, \leq_X)$ be a defining O-forest (we have $M_X \supseteq X$). We let \mathbb{N}^R be \mathbb{N} ordered by reversing the natural order. We assume these forests U_X pairwise disjoint and disjoint from \mathbb{N}^R . We let W be the union of \mathbb{N}^R and the U_X 's ordered as follows :

$x \leq_W y$ if and only if

$x \leq y$ in \mathbb{N}^R or $x \leq_X y$ for some component X , or x is in some M_X and $y \in \mathbb{N}$.

Then W is an O-tree and $B = B_W \cap N^3$.

(2) Let $S = (N, B)$ such that $B = B_U \cap N^3$ for some O-forest $U = (M, \leq)$. Let M' be the union of the lines $L_{\geq}(x)$ of U for all $x \in N$. Then $U' := U[M']$ is an O-forest and $B = B_{U'} \cap N^3$. We prove that it is an O-tree if furthermore S is connected. If x and y belong to a triple in B , then they have an upper-bound in M' by the definition of B_U and, furthermore, any $x' \geq x$ and $y' \geq y$ also have an upper-bound in M' . Let $u, v \in M'$. There is a path $x_1 - x_2 - \dots - x_n$ in $Gf(S)$ such that $u \geq x_1$ and $v \geq x_n$. Hence we have z_1, z_2, \dots, z_{n-1} such that z_1 is an upper-bound of u and x_2 , z_2 is an upper-bound of z_1 and x_3 , ..., z_{n-1} is an upper-bound of z_{n-2} and $v \geq x_n$. We have $z_{n-1} \geq u$. Hence, U' is an O-tree. \square

The converse of Assertion (2) may be false: consider a *star* $T = (N, \leq)$ with root¹ r and $S := (N - \{r\}, B)$ where $B := B_T[(N - \{r\})]$. Then, S is in **IBO**, defined from a tree, but not connected as B is empty.

Definition 4.5 : *Marked join-trees and related notions*

(a) A *marked join-tree* is a 4-tuple $T = (M, \leq, M_{\oplus}, M_{\otimes})$ such that (M, \leq) is a join-tree and M_{\oplus}, M_{\otimes} are disjoint subsets of M that contain no leaf. We let $V_T := M - (M_{\oplus} \uplus M_{\otimes})$. Its *size* is $|M|$.

(b) We define the *betweenness relation* $B_T \subseteq V_T^3$ of T as follows:

$$B_T(x, y, z) : \iff \neq (x, y, z) \wedge x \sqcup_T z \notin M_{\oplus} \wedge ([x < y \leq x \sqcup_T z] \vee [z < y \leq x \sqcup_T z]).$$

The join $x \sqcup_T z$ is always defined as T is a join-tree. We have $B_T(x, y, z)$ if $x < y < z$.

We let $S_T := (V_T, B_T)$ be the *betweenness structure* of T . The Gaifman graph of S_T has vertex set V_T .

(c) If we delete from T all nodes of degree 1 belonging to $M_{\oplus} \uplus M_{\otimes}$, we obtain a marked join-tree having the same betweenness structure and that join-embeds into T (cf. Definition 3.1(e)). We call *reduced* such a marked join-tree.

(d) If M_{\oplus} is empty, then $(V_T, B_T) \in \mathbf{IBQT}$.

Lemma 4.6 : Let $T = (M, \leq, M_{\oplus}, M_{\otimes})$ be a marked join-tree.

(1) If $U = (N, \leq, N_{\oplus}, N_{\otimes})$ join-embeds in T , then $B_U = B_T[N \cap V_T]$.

(2) If $X \subseteq V_T$ and $B = B_T[X]$, then there exists U as in (1) such that $B_U = B$.

(3) If T_1, \dots, T_n, \dots is a sequence of marked join-trees such that $T_i \subseteq_j T_{i+1}$ and T is the union of the T_i 's, then B_T is the union of the increasing sequence $B_{T_1} \subseteq_i B_{T_2} \subseteq_i \dots B_{T_n} \subseteq_i \dots$

¹All other nodes are adjacent to the root.

Proof : (1) Since U join-embeds into T , if $x, y \in N \cap V_T$, then $x \sqcup_U y = x \sqcup_T y$ and this join belongs to M_\oplus (resp. M_\otimes) if and only if it belongs to N_\oplus (resp. to N_\otimes). The result follows from the definitions.

(2) Let $T = (M, \leq, M_\oplus, M_\otimes)$ be a marked join-tree and $N \subseteq M$. Let us remove from T all subtrees T/u that contain no node of N . We obtain $U = (N', \leq, N_\oplus, N_\otimes)$, a marked join-tree that join-embeds in T and $V_U = N \cap V_T$. Hence we have $B = B_T[N] = B_U$ by (1).

(3) We have $T_n \subseteq_j T$ for each n . The result follows. \square

Proposition 4.7 : (1) A structure $S = (N, B)$ is in **IBO** if and only if $B = B_T$ for a marked join-tree $T = (M, \leq, M_\oplus, M_\otimes)$ such that $V_T = N$.

(2) If N is finite, then T can be chosen finite of size at most $2|N| - 1$.

Proof: (1) "If" direction. Let $S_T := (V_T, B_T)$ be defined from a marked join-tree $T = (M, \leq, M_\oplus, M_\otimes)$. We will construct an O-tree $U = (W, \leq')$ such that $M - M_\oplus \subseteq W$ and $B_U[V_T] = B_T$.

For each node x in M_\oplus , we let \mathbb{N}_x^R be an isomorphic copy of \mathbb{N} ordered by reversing the natural ordering. Hence \mathbb{N}_x^R has no least element. We choose these copies pairwise disjoint and disjoint with M .

We define $U := T[\mathbb{N}_x^R/x; x \in M_\oplus]$. It is an O-tree by Definition 3.2 (where substitutions are defined).

If $x \sqcup_T z \in M_\oplus$, then x and z have no join in U .

Let $x, y, z \in V_T$ be such that $B_T(x, y, z)$ holds. If $x < y < z$ or $z < y < x$ in T , then the same holds in U and $B_U(x, y, z)$ holds. Otherwise, x and z are incomparable and $x < y \leq x \sqcup_T z > z$ or $x < x \sqcup_T z \geq y > z$. Then, $x \sqcup_T z$ is either in V_T or is labelled by \otimes . In both cases, $x \sqcup_T z$ is the join of x and z in U . Hence, $B_U(x, y, z)$ holds.

Conversely, assume that $x, y, z \in V_T$ and $B_U(x, y, z)$ holds. If $x < y < z$ or $z < y < x$ in U , then the same holds in T and $B_T(x, y, z)$ holds. Otherwise, x and z are incomparable and $x < y \leq x \sqcup_U z > z$ or $x < x \sqcup_U z \geq y > z$. Then x and z have a join m in T . It must be in $V_T \cup M_\otimes$, otherwise, $x \sqcup_U z$ does not exist because it would be the minimal element of \mathbb{N}_m^R . Hence $B_T(x, y, z)$ holds. Hence $S \in \mathbf{IBO}$.

"Only if" direction. Conversely, assume that $S = (N, B)$ in **IBO** is defined from an O-tree $U = (M, \leq)$ such that $N \subseteq M$ and $B = B_U \cap N^3$. We can assume that for every $y \in M$, we have $x \leq y$ for some $x \in N$: if this is not the case, we replace M by the union M' of the upwards closed lines $L_{U \geq}(x)$ for all $x \in N$ and, letting $U' := (M', \leq)$, we have $N \subseteq M'$ and $B = B_{U'} \cap N^3$.

Let $W = (P, \leq)$ be the join-completion of U , cf Definition 3.3. We label by \otimes a node in $M - N$, and by \oplus a node in $P - M$. These latter nodes have been added to U in place of missing joins, according to Proposition 3.4.

Claim : $B = B_W$.

Proof : $B \subseteq B_W$. Let $B(x, y, z)$. If $x < y < z$ or $z < y < x$ in U then the same holds in W and $B_W(x, y, z)$ holds.

Otherwise, x and z are incomparable and $x < y \leq x \sqcup z > z$ or $x < x \sqcup z \geq y > z$ in U . Then $x \sqcup z$ is in N or is labelled by \otimes in W . Hence, $B_W(x, y, z)$ holds. Then $x \sqcup z$ is not labelled by \oplus .

Conversely, assume that $B_W(x, y, z)$ holds. A similar proof establishes that $B(x, y, z)$ holds. \square

If $S = (N, B)$ in **IBO** is defined from an O-forest $U = (M, \leq)$ as opposed to an O-tree, then its connected components are defined by O-trees. For each of them, we have a marked join-tree. We put them together in a marked join-tree with a root labelled by \oplus . (Similar to the proof of Lemma 4.4(2)).

(2) Let $S = (N, B)$ in **IBO** be finite and defined from a marked join-tree $T = (M, \leq, M_\oplus, M_\otimes)$ such that $N = V_T$ and $B = B_T$. By removing the nodes in $M_\oplus \cup M_\otimes$ of degree 1, we obtain a reduced marked join-tree that defines S and has at most $2|N| - 1$ nodes. \square

Remark 4.8 : We observed in Proposition 2.15 of [7] that a finite structure in **IBO** may not be defined from any *finite* O-forest U (cf. Definition 4.1). Marked join-trees remedy this "defect" and yield Proposition 4.7, a key fact for our proof.

Example 4.9 : We consider $S = (N, B)$ in **IBO** defined from the infinite O-tree on the left of Figure 1 where $N = \{0, a, a', b, b', c, c', d, d', e, e'\}$. We have:

- (a) $B(a', a, 0), B(b', b, 0), B(c', c, 0), B(d', d, 0), B(e', e, 0),$
- (b) $B^+(a', a, b, b'), B^+(c', c, d, d'), B^+(a', a, e, e'), B^+(b', b, e, e'),$
 $B^+(c', c, e, e')$ and $B^+(d', d, e, e')$.

We do not have $B^+(a', a, c, c')$ because a and c have no join, as the dotted line represents \mathbb{N}^R .

The right part shows a finite marked join-tree $T = (M, \leq, M_\oplus, M_\otimes)$ where z has been added as join of x and y and the nodes $2, 3, \dots, n, \dots$ of degree 1 above z have been deleted (cf. Definition 3.1 for the degree).

We have $M = N \cup \{1, x, y, z\}, M_\oplus = \{z\}, M_\otimes = \{1, x, y\}$ and $B_T = B$. \square

Proposition 4.10 : The class **IBO** is finitary, that is, S is in **IBO** if and only if each of its finite induced substructures is.

Proof : The "only if" direction is clear as, by its definition, the class **IBO** is hereditary, *i.e.*, closed under taking induced substructures.

"If" direction. First, some observations. If $S = (V_T, B)$ is defined from a marked join-tree $T = (N, \leq, N_\oplus, N_\otimes)$ and $S' \subseteq_i S$, then the restriction T' of T to $\{x \in N \mid x \geq y \text{ for some } y \in V_T\}$ is a marked join-tree that defines S' . By reducing it (Definition 4.5(c)), we get $T'' \subseteq_j T$ that defines S' .

By Proposition 4.7, each finite structure $S = (N, B)$ in **IBO** of size $m = |N|$ is defined by marked join-trees of size at most $2m - 1$. We let $J(S)$ be the finite set of all such join-trees, up to isomorphism.

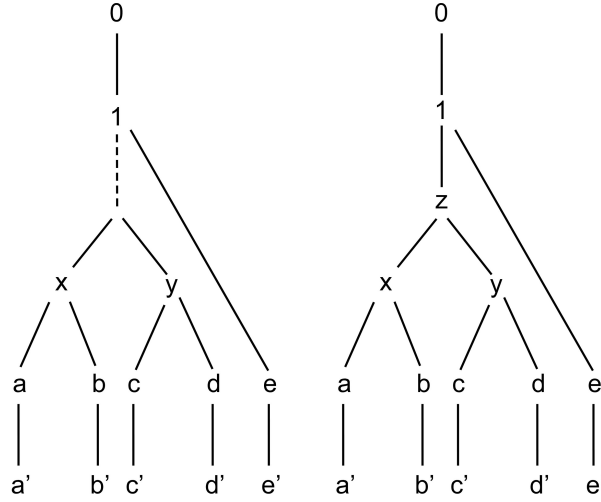

Figure 1: See Example 4.9. In the O-tree to the left, we have $0 > 1 > 2 > 3 > \dots > n > \dots$ above x and y .

For proving the statement, we let $S = (N, B)$ be infinite. It is the union of an increasing sequence $S_1 \subset_i S_2 \subset_i \dots \subset_i S_n \subset_i \dots$ of finite induced substructures that we assume to be in **IBO**.

We will use the following version of Koenig's Lemma. Let $A_1, A_2, \dots, A_n, \dots$ be an infinite sequence of pairwise disjoint finite sets, and A be their union. Let $R \subseteq A \times A$ be such that for every b in $A_n, n > 1$, there is $a \in A_{n-1}$ such that $(a, b) \in R$. Then, there exists an infinite sequence a_1, \dots, a_n, \dots such that $(a_{n-1}, a_n) \in R$ for each $n > 1$.

The finite sets $J(S_n)$ are pairwise disjoint. We define

$$R := \{(T, T') \mid T \in J(S_{n-1}), T' \in J(S_n), n > 1 \text{ and } T \subset_j T'\}.$$

It follows from Lemma 4.6(2) that if $T' \in J(S_n)$ and $n > 1$, we have $(T, T') \in R$ for some $T \in J(S_{n-1})$.

Hence, there is an infinite sequence of marked join-trees

$$T_1 \subset_j T_2 \subset_j \dots \subset_j T_n \subset_j \dots \text{ such that } T_n \in J(S_n) \text{ for each } n.$$

By Lemma 4.6(3), their union is a marked join-tree T such that $T_n \subset_j T$ for each n . We obtain an increasing sequence of finite marked join-trees whose union is a marked join-tree that defines S . Hence $S \in \mathbf{IBO}$. \square

The proof of Theorem 4.2(1) reduces to that of the following proposition.

Proposition 4.11: There is an MSO-sentence that characterizes the finite connected structures in **IBO** among the finite ternary structures.

Proof of Theorem 4.2(1), assuming proved Proposition 4.11 :

Let φ be the MSO sentence such that, for every finite ternary structure $S = (N, B)$:

$S \models \varphi$ if and only if S is connected and in **IBO**.

Consider the MSO_{fin} sentence ψ :

$$\forall X.(\gamma(X) \wedge \text{Fin}(X) \implies \varphi[X]),$$

where $\gamma(X)$ expresses that X is connected in the Gaifman graph $Gf(S)$ and $\varphi[X]$ is the relativization of φ to X .

Relativizing a sentence to a set, here X , is a classical construction in logic, see e.g. [10], Section 5.2.1 for monadic second-order logic. If $S = (N, B)$ is a ternary structure and $X \subseteq N$, then $S \models \varphi[X]$ if and only if $S[X] \models \varphi$.

We prove that $S \models \psi$ if and only if S is in **IBO**.

If S is in **IBO**, then every induced substructure $S[X]$, in particular every finite and connected one satisfies φ , hence $S \models \psi$.

Conversely, assume that $S \models \psi$. Let X be a finite subset of N . If it is connected in $Gf(S)$, then $\varphi[X]$ holds hence $S[X]$ is in **IBO**. Otherwise, it is a disjoint union of connected sets in $Gf(S)$. For each of them, say Y , the validity of ψ implies that $\varphi[Y]$ holds, $S[Y]$ is in **IBO** and so are $S[X]$ by Lemma 4.4(1) and S by Proposition 4.10. \square

4.2 Overview of the proof of Proposition 4.11

For proving Proposition 4.11, we will handle finite objects: graphs, rooted trees, rooted forests and structures (N, B) . All trees and forests will be rooted, so we call them simply trees and forests. We need some more definitions.

Definition 4.12 : *Forests compatible with a ternary relation.*

A rooted forest $T = (N, \leq_T)$ is *compatible with a relation* $B \subseteq N^3$ satisfying Axioms A1-A6 if, for all $x, y, z \in N$:

- (i) if $B(x, y, z)$ holds, then $x <_T y$ or $z <_T y$,
- (ii) if $B(x, y, z)$ and $x <_T y >_T z$ hold, then $y = x \sqcup_T z$.
- (iii) if $x <_T z$, then $B(x, y, z)$ holds if and only if $x <_T y <_T z$. \square

Lemma 4.13 : Let $S = (N, B) \in \mathbf{IBO}$ be finite, connected and defined from a finite reduced marked tree $U = (N \uplus N_\oplus \uplus N_\otimes, \leq_U, N_\oplus, N_\otimes)$.

(1) Then $T := U[N] = (N, \leq_T)$ is a finite forest compatible with B , where \leq_T is the restriction of \leq_U to N .

(2) The order \leq_T is FO-definable in the structure (N, B, R) where R is the set of roots of T . \square

The forest T is not necessarily a tree because the root of U need not be in N . This root cannot be labelled by \oplus , otherwise S is not connected (we exclude the trivial case where N is singleton).

Proof : (1) Let S, T, U as in the statement.

(i) If $B(x, y, z)$ holds, then:

either $x <_U y <_U z$ or $z <_U y <_U x$
or $x \sqcup_U z \wedge [(x <_U y \leq_U x \sqcup_U z) \vee (z <_U y \leq_U x \sqcup_U z)]$,
where in the latter case, $x \sqcup_U z \in N \cup N_\otimes$.

In all cases, we have $x <_U y$ or $z <_U y$, hence $x <_T y$ or $z <_T y$.

(ii) If $B(x, y, z)$ and $x <_T y >_T z$ hold, then the above description of $B(x, y, z)$ shows that $y \leq_U x \sqcup_U z$. As we have $x <_U y >_U z$, we must have $y = x \sqcup_U z$. If y is not $x \sqcup_T z$, we have $m \in N$ such that $x < m$ and $z < m < y$ in T and in U . But then y is not the join of x and z in U and $y = x \sqcup_T z$.

(iii) Clear from the definitions because \leq_T is the restriction of \leq_U to N .

(2) If $R = \{r\}$, then $x \leq_T y$ if and only if $x = y$ or $y = r$ or $B(x, y, r)$ holds. Otherwise, the root of U is in N_\otimes and has degree at least 2. Let x and y be not in R .

Claim : (a) If $r \in R$, we have $x <_T r$ if and only if $B(x, r, r')$ holds for some $r' \in R$.

(b) We have $x <_T y$ if and only if $B(x, y, r)$ holds for some $r \in R$.

Proof: (a) Assume that $x <_T r$. There is $r' \in R$ such that $r \sqcup_U r'$ has label \otimes . Hence $B(x, r, r')$ holds.

Conversely, if $B(x, r, r')$ holds for some $r' \in R$, we have $x <_T r$ or $r' <_T r$ because T is compatible with B . As r and r' are different and are distinct roots of T , they are incomparable and we have $x <_T r$.

(b) If $x <_T y$, we have $x <_T y <_T r$ for some $r \in R$. Hence $B(x, y, r)$ holds since T is compatible with B .

Conversely, if $B(x, y, r)$ holds for some $r \in R$, then, we have $x <_T y$ or $r <_T y$. The latter is not possible as r is a root. \square

Let $\psi(R, x, y)$ be the following FO formula (an FO formula may have free set variables and use atomic formulas $x \in X$):

$$\begin{aligned} x = y \vee [x \neq y \wedge \exists r (R = \{r\} \wedge [y = r \vee B(x, y, r)])] \\ \vee [x \neq y \wedge \exists r, r' \in R (y = r \wedge B(x, y, r'))] \\ \vee [x \neq y \wedge y \notin R \wedge \exists r \in R. B(x, y, r)]. \end{aligned}$$

By the claim, it defines $x \leq_T y$ since R is the set of roots of T .

We let $\varphi(R)$ be the FO formula relative to ternary structures $S = (N, B)$ expressing the following:

" $R \subseteq N$ and the binary relation $x \leq y$ on N defined by $S \models \psi(R, x, y)$ is a partial order and $T := (N, \leq)$ is a forest that is compatible with B and whose set of roots is R ". \square

Proposition 4.14 : Let $S = (N, B)$ satisfy properties A1-A6.

(1) For every $R \subseteq N$ such that $S \models \varphi(R)$, if we let \leq be defined by $\psi(R, x, y)$, then $T := (N, \leq)$ is a forest compatible with B .

(2) Every forest $T := U[N]$ defined from a finite marked tree $U = (N \uplus N_{\oplus} \uplus N_{\otimes}, \leq_U, N_{\oplus}, N_{\otimes})$ such that $B_U = B$ is described by the formulas $\varphi(R)$ and $\psi(R, x, y)$.

Proof : The first assertion follows from the definition of φ . The second one follows from Lemma 4.13(2). \square

All forests T compatible with B of potential interest for checking that S is in **IBO** can be described in terms of their sets of roots R by the existential MSO formulas $\exists R. \varphi(R)$ and $\psi(R, x, y)$.

We will construct MSO formulas to "check" that a "guessed" forest T satisfies additional requirements implying that $T := U[N]$ for some finite marked tree U witnessing that $S \in \mathbf{IBO}$.

In some T that has been "guessed", we will insert (if possible) nodes labelled by \oplus or \otimes so as to make it into the desired marked tree U . We will insert nodes in T in the following cases:

(1) If $a' < a$, $b \perp a$, $B(a', a, b)$ holds and there is no x in T such that $\{a, b\} < x$ and $B(a, x, b)$ holds, then we insert $a \sqcup_U b$ labelled by \otimes such that $a \sqcup_U b < m$ where m is any upper-bound in T of $\{a, b\}$.

(2) If $a' < a$, $b \perp a$ but $B(a', a, b)$ does not hold, then we insert $a \sqcup_U b$ as above labelled by \oplus .

In Case (1) a and b may have a join m in T but we need to insert a "new join" $a \sqcup_U b < m$.

Example 4.15 : The left part of Figure 2 shows a tree T constructed from the following facts relative to $N := \{a', a, b, c', c, d, e', e, 1, 0\}$:

- (a) $B^+(a', a, 1, 0), B(b, 1, 0), B^+(c', c, 1, 0), B(d, 1, 0), B^+(e', e, 1, 0),$
- (b) $B^+(a', a, c, c'), B(a', a, d), B(b, c, c'),$
- (c) $B^+(a', a, 1, e, e'), B^+(b, 1, e, e'), B^+(c', c, 1, e, e')$ and $B^+(d, 1, e, e')$.

Facts (b) indicate the need of joins $a \sqcup c$, $a \sqcup d$, and $b \sqcup c$ labelled by \otimes in the marked tree U to be constructed. These joins are all equal to x in the tree in the middle of Figure 2. The absence of facts $B(a', a, b)$ and $B(c', c, d)$ indicates the need of \oplus -labelled joins y and z , respectively between a, b and x , and between c, d and x . However, no triple in B necessitates that b and d have a \otimes -labelled join. A corresponding marked tree is shown in the middle of Figure 2.

Consider now $N' := \{a', a, b, d, e', e, 1, 0\} \subseteq N$ and $B' := B[N']$. We get a marked tree for B' by deleting c, c' and z from the previous one. However, another one shown to the right, that defines (N', B') where x is labelled by \otimes and z by \oplus . \square

We need more definitions. We let B, T, U and R , be as in Lemma 4.13.

Definitions 4.16 : *Cographs and pp-cographs defined from T and, either U or B .*

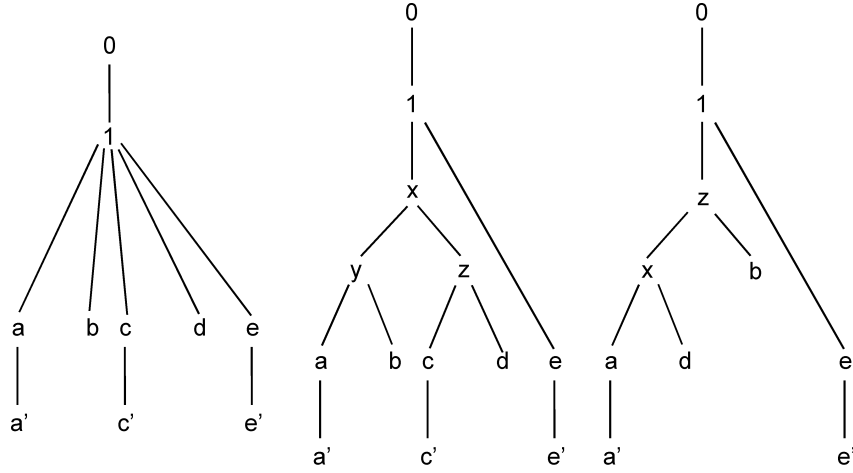

Figure 2: Example 4.15

(a) For each node x of T with sons $y_1, \dots, y_s, s \geq 2$, we define $y_i \sim_x y_j$ if and only if $i = j$ or $y_i \sqcup_U y_j \neq x$ so that this join has label \otimes or \oplus . It is clear that \sim_x is an equivalence relation.

We have $y_i \sim_x y_j$ if and only if $B(y_i, x, y_j)$ does not hold, by (ii) of compatibility, Definition 4.12.

(b) For each class C of the equivalence relation \sim_x , we define $G_{x,C}$ as the 2-graph (C, E, C_1, C_2) such that:

$y \in C_2$ if and only if $y' < y$ for some $y' \in N$,

$y - z$ is an edge if and only if y or z is in C_2 and $y \sqcup_U z$ has label \otimes .

There are no edges between vertices in C_1 . Hence $G_{x,C}$ is a pp-cograph. We obtain a cograph if we add edges $y - z$ such that y and z are in C_1 and $y \sqcup_U z$ has label \otimes .

(c) Let $R = \{r_1, \dots, r_p\}, p \geq 2$. We let G_{root} be the 2-graph (R, E, R_1, R_2) defined as $G_{x,C}$ above, where R replaces C and $y \in R_2$ if and only if $y' < y$ for some $y' \in N$. It is also a pp-cograph. \square

Lemma 4.17 : The edges $y - z$ of $G_{x,C}$ and G_{root} are characterized by the FO formula $(\exists y' < y. B(y', y, z)) \vee (\exists z' < z. B(z', z, y))$.

Proof : Consider $x \in N$ having sons y and z in a class C of \sim_x .

Let $y - z$ be an edge of $G_{x,C}$ such that $y \in C_2$ and $y \sqcup_U z$ has label \otimes . Then $B_U(y', y, z)$ holds for all $y' < y$ and so does $B(y', y, z)$ as $B = B_U$.

Conversely, if $y' < y \wedge B(y', y, z)$ holds, then the join $y \sqcup_U z$ must have label \otimes or be in N . But in the latter case, it must be x as y and z are sons of x . Hence, we have $B(y, x, z)$ but then, we do not have $y \sim_x z$. Hence, $y - z$ is an edge of $G_{x,C}$.

The proof is similar for G_{root} . The join $y \sqcup_U z$ cannot be in N as y, z are distinct roots. \square

It follows that the 2-graphs G_{root} and $G_{x,C}$ can be defined from B and T only, without using U that we are actually looking for. Furthermore, they can be described by FO formulas in the structure (N, B, R) . The formulas $\varphi(R)$ and $\psi(R, x, y)$ are defined before Proposition 4.14.

Proposition 4.18 : Let $S = (N, B)$ and $T = (N, \leq)$ be defined by the formula $\psi(R, x, y)$ from some R satisfying $\varphi(R)$.

(1) There exists a marked tree $U \supseteq T$ such that $B = B_U$ if and only if the 2-graphs G_{root} and $G_{x,C}$ are pp-cographs.

(2) This condition is FO expressible in the structure (N, B, \leq) .

Proof: (1) The "only if" direction follows from the previous constructions.

Conversely, assume that each 2-graph $G_{x,C}$ (determined solely from T and B by Lemma 4.17) as in the statement is a pp-cograph. By adding some edges between its 1-vertices, we can get a cograph $H_{x,C} \supseteq G_{x,C}$. It is defined by an $\{\oplus, \otimes\}$ -tree $t_{x,C}$ (Definition 2.1(c)), a tree whose internal nodes are labelled by \oplus or \otimes and whose set of leaves is C .

Similarly, if T has several roots and G_{root} is a pp-cograph, there is a cograph $H_{root} \supseteq G_{root}$ defined by a $\{\oplus, \otimes\}$ -tree t_{root} whose set of leaves is R .

By inserting in T the internal nodes of $t_{x,C}$ between x and the nodes in C , for all relevant pairs (C, x) , and those of t_{root} above the roots of T , we get a marked tree U such that $U \supseteq T = U[N]$ and $B = B_U$.

This can be formalized as follows. By bottom-up induction, we define marked trees T_x and $T_{x,C}$ for each x in N and equivalence class C of the relation \sim_x . We assume that the trees $t_{x,C}$ and t_{root} are pairwise disjoint.

(a) If x is a leaf, then $T_x := x$. There is no set C to consider.

Otherwise, $T_x := x(\dots, T_{x,C}, \dots)$ where the list covers all equivalence classes C of \sim_x . (We use the linear notation of finite trees defined in Section 1).

(b) If $C = \{y\}$, then $T_{x,C} := T_y$.

Otherwise, we use the $\{\oplus, \otimes\}$ -tree $t_{x,C}$ as follows: $T_{x,C} := t_{x,C}[\dots, T_y/y, \dots]$, denoting the substitution in $t_{x,C}$ of T_y for each $y \in C$ (it is a leaf of $t_{x,C}$).

(c) To complete the construction, we define $U := T_r$ if T is a tree with root $r \in N$.

Otherwise, $U := t_{root}[\dots, T_r/r, \dots]$ denoting the substitution in t_{root} of T_r for each leaf $r \in R$ (it is a leaf of t_{root}).

It is clear that U is a marked tree $(N \uplus N_{\oplus} \uplus N_{\otimes}, \leq_U, N_{\oplus}, N_{\otimes})$ and that $T = U[N]$.

Claim : $B_U = B$.

Proof : Note that \leq_T is the restriction of \leq_U to N .

If x and z are comparable, then $(x, y, z) \in B_U$ if and only if $x <_U y <_U z$ if and only if $x <_T y <_T z$ if and only if $(x, y, z) \in B$ since T is compatible with B .

We now assume $x \perp z$ and $(x, y, z) \in B$.

Let $u := x \sqcup_U z$. By the compatibility of T with B (point (ii)), we have $x <_T y$ or $z <_T y$.

(a) If $u \in N$, then $u = x \sqcup_T z$. Again by compatibility (point (i)), we do not have $u <_T y$. Hence, we have $x <_T y \leq_T u >_T z$ or $z <_T y \leq_T u >_T x$. The same inequalities hold with \leq_U hence $(x, y, z) \in B_U$.

(b) Otherwise, u has label \oplus or \otimes . Let x' be maximal in N such that $x \leq x'$ and z' be similar for z .

(b.1) If x' and z' have no upper-bound in T , they are distinct roots and u is an internal node of G_{root} .

As noted above, we have $x <_T y$ or $z <_T y$. Assume the first, *w.l.o.g.*. Then $x <_T y \leq_T x'$.

If u has label \otimes then $B_U(x, y, z)$ holds by the definition of B_U .

(If u has label \oplus then $B_U(x, y, z)$ does not hold, but the definition of the edges of G_{root} gives that $B_U(x, y, z)$ does not hold.)

(b.2) If x' and z' have a least upper-bound m in T , then, $u <_U m$. We have two cases:

Case 1 : $B(x, m, z)$ holds. We cannot have $y >_T m$, hence, we have $x <_T y \leq_T m >_T z$ or $z <_T y \leq_T m >_T x$. The same inequalities hold with \leq_U , hence $(x, y, z) \in B_U$.

Case 2 : if $B(x, m, z)$ does not hold. Then $x' \sim_m z'$ (we cannot have $B(x', m, z')$) and so x' and z' belong to a same class C of \sim_m . Then we use the same argument as above with $G_{m,C}$ instead of G_{root} .

The proof that $B_U \subseteq B$ is similar. \square

This completes the proof of Assertion (1).

(2) The following facts can be expressed in the structure (N, \leq, B) such that $S = (N, B)$ satisfies A1-A6 and $T = (N, \leq)$ is a forest compatible with B by MSO formulas that are easy to write explicitly:

$\alpha(R, R_1, R_2)$: R is the set of root of T , it is not singleton and (R_1, R_2) is its partition defined in Definition 4.16(c).

$\beta(x, y, z)$: $y < x \wedge z < x \wedge y \sim_x z$, (y and z are sons of x in T) cf. Definition 4.16(a).

$\gamma(x, C, C_1, C_2)$: C is a set of sons of x and an equivalence class of \sim_x , (C_1, C_2) is its partition defined in Definition 4.16(b).

$\eta(R, y, z)$: $y - z$ is an edge of G_{root} .

$\eta'(x, C, y, z)$: $y - z$ is an edge of $G_{x,C}$.

$\pi(R)$: R is not singleton and G_{root} is a pp-cograph (we use α and η).

$\pi'(x, C, y, z)$: $G_{x,C}$ is well-defined and is a pp-cograph (we use γ and η').

It is MSO expressible in (N, B, \leq) by Proposition 2.4(1) whether the 2-graphs G_{root} and $G_{x,C}$ are all pp-cographs. The condition of Assertion (1) is thus MSO expressible in the structure (N, B, \leq) by an MSO sentence μ . \square

Proof of Proposition 4.11: We prove that an MSO-sentence can characterize the finite connected structures in **IBO** among the finite ternary structures. There is an MSO sentence χ expressing that a ternary structure $S = (N, B)$ is connected and satisfies A1-A6. The sentence over $S = (N, B)$ defined as

$\exists R.(\varphi(R) \wedge \mu'(R))$ where μ' translates μ (of Proposition 4.18(2)) by using $\psi(R, x, y)$ to define \leq expresses well that S is in **IBO** by Proposition 4.18(1). Hence, $\chi \wedge \exists R.(\varphi(R) \wedge \mu'(R))$ is the desired sentence. \square

4.3 Well-quasi-orderings and the finiteness of $Bnd(\mathbf{IBQT})$

We recall definitions and a result from [18].

Definitions 4.19 :

(a) If \mathcal{C} is a class of finite structures $S = (N, R_1, \dots, R_p)$, if m is the maximal arity of a relation R_i , we define $\mathcal{U}(\mathcal{C})$ as the class of structures $(N, R_1, \dots, R_p, U_1, \dots, U_{2m-1})$ for all S in \mathcal{C} , where U_1, \dots, U_{2m-1} are unary, hence denote subsets of N .

(b) The class $\mathcal{U}(\mathcal{C})$ is *well-quasi-ordered* (implicitly by induced inclusion) if, for every infinite sequence S_1, S_2, \dots of structures in this class, there are $j < k$ such that S_j is isomorphic to an induced substructure of S_k , denoted by $S_j \subseteq_{i\sim} S_k$. \square

With these hypotheses and notation, Corollary 2.4 of [18] (also Theorem² 13.2.3 of [13]) states the following. (The class $Bnd(\mathcal{C})$ of bounds is defined in Section 1. Its finiteness is up to isomorphism.)

Theorem 4.20 : If $\mathcal{U}(\mathcal{C})$ is well-quasi-ordered, then $Bnd(\mathcal{C})$ is finite.

The structures in $\mathcal{U}(\mathbf{IBO})$ are of the form (N, B, U_1, \dots, U_5) for (N, B) in **IBO**. Let \mathbf{T} be the set of finite structures $T = (N \uplus N_{\oplus} \uplus N_{\otimes}, \leq, N_{\oplus}, N_{\otimes}, U_1, \dots, U_5)$ such that $(N \uplus N_{\oplus} \uplus N_{\otimes}, \leq, N_{\oplus}, N_{\otimes})$ is a marked tree (Definition 4.5(a)), U_1, \dots, U_5 are subsets of N and $|N_{\oplus} \uplus N_{\otimes}| < |N|$.

Proposition 4.7(2) shows that every S in $\mathcal{U}(\mathbf{IBO})$ is defined from a marked tree T belonging to \mathbf{T} . We denote then $S = S(T)$. Precisely, $S(T) = (N, B_{T'}, U_1, \dots, U_5)$ where T' is the marked tree $T = (N \uplus N_{\oplus} \uplus N_{\otimes}, \leq, N_{\oplus}, N_{\otimes})$, cf. Definition 4.5(b).

Fact : If T, T' are in \mathbf{T} and $T \subseteq_{j\sim} T'$, then $S(T) \subseteq_{i\sim} S(T')$.

It is a corollary of Lemma 4.6(1).

Proposition 4.21 : The class of finite structures in $\mathcal{U}(\mathbf{IBO})$ is well-quasi-ordered.

Proof : Let S_1, S_2, \dots be an infinite sequence of finite structures in $\mathcal{U}(\mathbf{IBO})$. For each S_i , we let T_i in \mathbf{T} be such that $S(T_i) = S_i$. By Kruskal's Theorem, $T_i \subseteq_{j\sim} T_k$ for some $i < k$. The above fact yields $S_i \subseteq_{i\sim} S_k$. \square

Theorem 4.2(2) : The class **IBO** has finitely many bounds.

²Fraïssé states the result with $2m$ instead of $2m - 1$ but translates from French the proof by Pouzet.

Proof : The class of finite structures in **IBO** has finitely many bounds by Proposition 4.21 and Theorem 4.20. The result holds by Proposition 4.10. \square

Remark 4.22 : This proof yields a quick proof that $Bnd(\mathbf{IBQT})$ is finite by using the finite marked trees $T = (N \uplus N_{\oplus} \uplus N_{\otimes}, \leq, N_{\oplus}, N_{\otimes})$ such that N_{\oplus} is empty. We know that from Proposition 2.12 of [7] from which $Bnd(\mathbf{IBQT})$ can be effectively constructed, whereas proofs using well-quasi-orderings do not yield effective constructions.

In Section 6, we will explain why computing the bounds of **IBO** is even harder than computing those of probe cographs.

5 Clique-width and the bounds of probe cographs

We discuss some properties of probe cographs. We first review clique-width.

Definition 5.1 : *Clique-width.*

(a) Graphs are built with the help of vertex labels (in addition to the labels of 2-graphs). Each vertex has a *label* in a set L . The nullary symbol $\mathbf{a}(x)$ where $a \in L$, denotes the isolated vertex x labelled by a . The operations are the union \oplus of disjoint graphs, the unary operations $add_{a,b}$ for $a, b \in L$, $b \neq a$, that adds to a graph an edge between each a -labelled vertex and each b -labelled vertex (unless they are already adjacent), the unary operation $relab_{a \rightarrow b}$ that changes every vertex label a into b .

(b) A term over the above defined operations is *well-formed* if no two occurrences of nullary symbols denote the same vertex (so that the graphs defined by two arguments of any operation \oplus are disjoint). We call them the *clique-width terms*. Each term t denotes a vertex labelled graph $\mathbf{val}(t)$ whose vertices are those specified by the nullary symbols of t . Its *width* is the number of labels that occur in t . The *clique-width* of a graph G without labels from L (but possibly with labels from another set like $\{1, 2\}$), denoted by $cwd(G)$, is the least width of a term t that denotes some vertex labelling of G .

(c) Clique-width terms may contain redundancies: for example $add_{a,b}(add_{c,d}(add_{a,b}(G))) = add_{c,d}(add_{a,b}(G))$ and $relab_{a \rightarrow b}(relab_{a \rightarrow c}(G)) = relab_{a \rightarrow c}(G)$ for every graph G . It follows that each graph of clique-width at most k is defined by infinitely many terms written a fixed set L of k labels. However, one can "normalize" these terms so as to avoid these redundancies. This is done in Proposition 2.121 of [10]. Let us call *normal* such a term. Then, each graph of clique-width at most k is defined by finitely many normal terms using the labels in $L := [k]$. Furthermore, the set N_k of normal terms with labels in $[k]$ is recognizable by a finite automaton, see [10]. \square

Proposition 5.2 : The maximal clique-width of a probe cograph is 4.

Proof : The upper-bound, observed in [11], is easy to establish. The bound 4 is reached by the probe cograph defined by the term :

$$[\bullet_1(1) \oplus (\bullet_1(2) \otimes \bullet_2(7)) \oplus (\bullet_1(3) \otimes \bullet_2(8))] \otimes \\ [\bullet_1(4) \oplus (\bullet_1(5) \otimes \bullet_2(9)) \oplus (\bullet_1(6) \otimes \bullet_2(10))]$$

where the vertices 1,...,6 are 1-vertices and the vertices 7 to 10 are 2-vertices. It has clique-width³ 4. \square

Proposition 5.3: Apart from P_6 , the finitely many bounds of probe cographs have diameter at most 4 and clique-width at most 8. They are connected and MSO definable.

Proof : Since the class of probe cographs is closed under disjoint union, their bounds are connected.

We have observed that P_6 of diameter 5 is a bound. Any other graph of diameter at least 5 contains properly an induced path P_6 , hence is not a bound.

If a graph has $G - x$ has clique-width k , then G has clique-width at most $2k$ [14]. Hence, as probe cographs have clique-width at most 4, their bounds have clique-width at most 8.

If \mathcal{C} is a hereditary class of finite graphs, then its bounds form the class:

$$Bnd(\mathcal{C}) := \{G \mid G \notin \mathcal{C} \text{ and } G - x \in \mathcal{C} \text{ for each vertex } x \text{ of } G\}.$$

If \mathcal{C} is defined by an MSO sentence θ , then $Bnd(\mathcal{C})$ is defined by the MSO sentence :

$$\neg\theta \wedge \forall X.(\theta[X] \text{ and " } X \text{ is the set of all vertices minus one"}).$$

By Proposition 2.4(1) the class of pp-cographs is FO-definable. Hence, the class of probe cographs is MSO-definable: an existential set quantification is useful to guess a good labelling of the given graph. The corresponding MSO sentence is known from the knowledge of the bounds of pp-cographs. However, the class of probe cographs is FO-definable by Proposition 2.4(2), but we do not know the corresponding sentence as the bounds of probe cographs are not completely known. \square

Theorem 5.4 : There is an algorithm that can compute the finitely many bounds of the class of probe cographs. An upper-bound to their sizes is computable.

Proof sketch : By Proposition 5.3, we can construct effectively an MSO sentence ξ that defines the class \mathcal{B} of bounds of probe cographs among finite graphs. By Theorem 6.35 of [10] or an algebraic version of it in terms of recognizable sets (Corollary 5.59), one can build a finite automaton \mathcal{A} that recognizes the set of normal terms of width at most 8 that define the graphs in \mathcal{B} . Then

³The verification has been done by using the software TRAG [12] that is accessible on-line. It is based on [15].

$L(\mathcal{A})$ is finite as we know that \mathcal{B}_{\simeq} is. However, several terms in $L(\mathcal{A})$ may define isomorphic graphs. As $L(\mathcal{A})$ is finite, one can list its elements and thus the graphs it defines after removing isomorphic duplicates.

The MSO sentence ξ can be replaced by $\xi \wedge \delta$ where δ is the MSO sentence expressing that a graph is connected and has a diameter at most 4. We obtain in this way a more restrictive set $L(\mathcal{A})$ without missing any graph in \mathcal{B} except P_6 , but we know it.

Pumping lemmas are classical tools of language theory by which one can bound the sizes of the terms of a finite recognizable set, without listing them. However the obtained bound would be ridiculous huge. \square

This decision procedure is actually intractable, because of the complexity of the sentence ξ and the size of the corresponding automaton, that needs to handle clique-width terms with 8 labels.

For the reader interested in determining exactly the bounds of probe cographs, we indicate those we know. We denote by \overline{G} the edge-complement of a graph G . By a *bound*, we mean a bound of probe cographs, hence, a graph in \mathcal{B} .

Proposition 5.5 : The following graphs, all of clique-width 3, are in \mathcal{B} :

- (1) The standard graphs C_5, P_6, C_6 .
- (2) The graphs $\overline{C_6}, D$ and \overline{D} derived from C_6 , see Figure 3.
- (3) Four graphs obtained by substituting K_2 (an edge) to one or two vertices of a path P_4 or P_5 . See Figure 4.
- (4) Two graphs obtained from the *house* H by substituting edges as in (3). See Figure 5.
- (5) Two graphs obtained as in (4) from p-cographs with 5 vertices.

Proof: The proofs are based on the following observations (cf. Example 2.5) :

the only good labellings of P_4 are 1212, 2121 and 1221,

the only good labelling of P_5 is 12121,

the two good labellings of the "house" H with vertices $\{a, b, c, d, e\}$ and top vertex c , cf. Figure 5, label either c and d , or c and b by 1 (and the other vertices by 2),

every good labelling of a graph is good for its induced subgraphs.

- (1) See Examples 2.5 for C_5 and P_6 .

Let $C_6 = a - b - c - d - e - f - a$. Assume for a contradiction that it has a good labelling. By removing a , we get P_5 , hence b and f must be labelled by 1, hence a must be labelled by 2. Similarly, b must be labelled by 2. As P_5 is a p-cograph, C_6 is a bound.

All further proofs work similarly, by producing contradictions from purported good labellings. In all cases, vertex deletions produce p-cographs. Hence, our graphs are bounds.

(2) The graph $\overline{C_6}$ is shown in Figure 3. By removing f , we get H with top vertex c that should be labelled by 1, so that either b or d should be labelled by 1. Hence, f must be labelled by 2, but it is the top vertex of the house $\overline{C_6} - c$. Hence, $\overline{C_6}$ is not a p-cograph. However, it is a bound.

The graph D is obtained from $C_6 = a - b - c - d - e - f - a$ by adding the edge $c - f$. By removing f , we see that a, c and e should be labelled by 1, and b by 2. If we remove c , we get a path P_5 of type 21212 which is not good.

From the graph \overline{D} shown in Figure 3, we get two "houses" by removing either c or f . Both vertices should be labelled by 1, so that none of the others can be labelled by 1.

(3) The path $P_5 = a - b - c - d - e$ has a unique good labelling of type 12121. If we substitute K_2 for either a, c or e , we obtain a bound. We obtain only two non-isomorphic bounds.

The path $P_4 = a - b - c - d$ has three good labellings of types 1212, 2121 and 1221. For each good labelling, at least one vertex in, either $\{a, b\}$, or $\{a, d\}$ or $\{c, d\}$ must be labelled by 1. This gives, up to isomorphism, the two bounds $P_4[K_2/a, K_2/b]$ and $P_4[K_2/a, K_2/d]$ shown in Figure 4.

(4) Every good labelling of the "house" H shown to the left of Figure 5, must label c by 1 and, either b or d , by 1. We obtain the two bounds $H[K_2/c]$ and $H[K_2/b, K_2/d]$ shown in Figure 4.

(5) Among the connected graphs with 5 vertices that are not cographs we have are C_5 and H . Figure 6 shows two others, H_1 and H_2 . Every good labelling of H_1 , labels b or d (or both) by 1. Hence $H_1[K_2/b, K_2/d]$ is not a p-cograph. It is a bound because $H_1[K_2/b]$ and $H_1[K_2/d]$ are p-cographs. Similarly, we get from H_2 , the bound $H_2[K_2/c, K_2/d]$.

The graphs C_5, P_6, C_6 are known to have clique-width 3. That $H, \overline{C_6}, D$ and \overline{D} have clique-width 3 can be checked with [12] or proved directly. All other bounds of (3), (4) and (5) are obtained by substituting K_2 to vertices of graphs of clique-width 3. Hence, they have clique-width 3. \square

We do not know any graph of clique-width 4 or more that is a bound of probe cographs. Hence, for now, we are far from the upper-bound 8 of Proposition 5.3.

6 Open problems

Problem 6.1 : Determine the set of bounds of probe cographs. What can be said about them in addition to what is stated in Proposition 5.3 ?

Monadic second-order logic does not help for effective computations because of the huge sizes of the automata constructed from MSO sentences.

Problem 6.2 : Does there exist a *monadic second-order transduction*, cf. Chapter 7 of [10], that transforms a finite ternary structure assumed to be in **IBO** into a finite marked tree defining it?

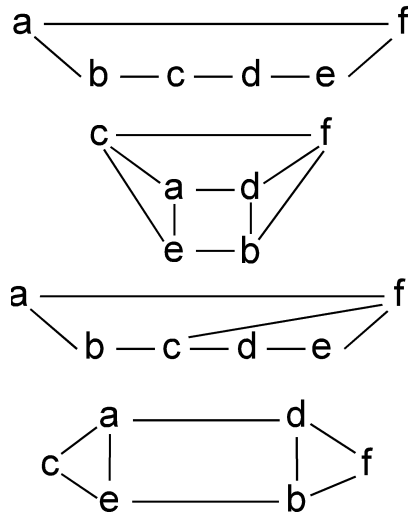

Figure 3: The bounds C_6 , $\overline{C_6}$, D and \overline{D} of Proposition 5.5(3).

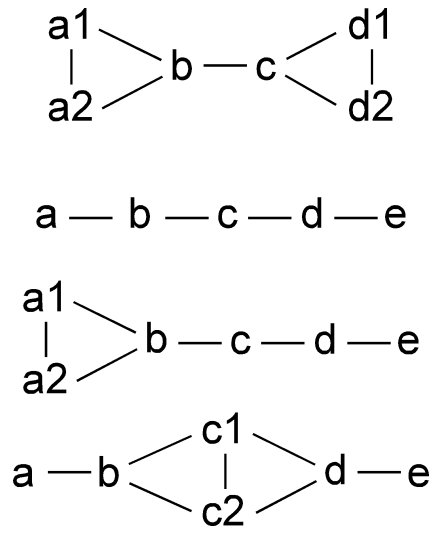

Figure 4: The bounds of Proposition 5.5(3).

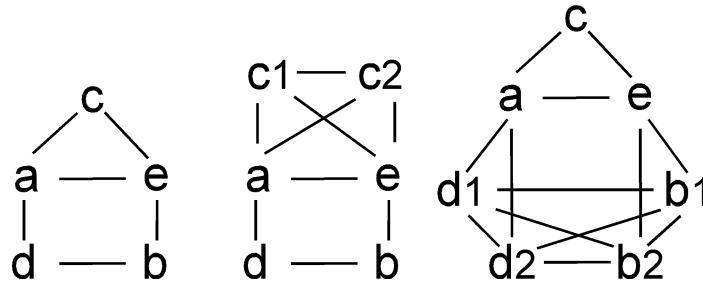

Figure 5: The "house" to the left (it is a p-cograph), and the two bounds of Proposition 5.5(4).

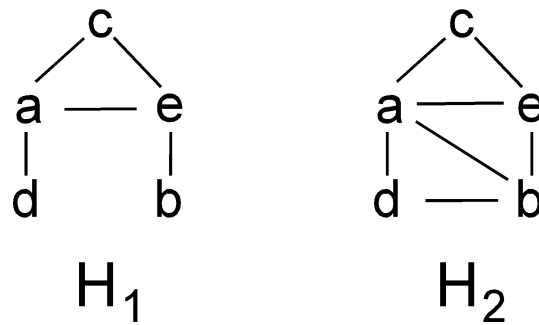

Figure 6: Two p-cographs used in Proposition 5.5(5)

In [7], we studied four classes of betweenness structures (cf. Definition 4.1) : **QT**, **IBQT**, **BO** and **IBO**. Each betweenness structure $S = (N, B)$ is defined from a labelled O-tree, say $T = (M, \leq, N_{\oplus}, N_{\otimes})$. This description covers all cases, although labels are useless in some cases.

The question is whether some witnessing O-tree T can be defined by MSO formulas in the given structure S , in technical words, by an MSO transduction. An FO transduction exists for **QT** and MSO transductions exist for **IBQT** and **BO**.

Theorem 4.2(1) establishes that the class **IBO** is MSO_{fin} -definable, without building an associated MSO transduction. We recall that an MSO-transduction transforms a structure with n elements into one with at most kn elements, for some fixed k . As a finite structure in **IBO** having n elements can be defined from a marked tree with at most $2n - 1$ nodes, it is not hopeless to look for such a transduction. An intermediate result seems necessary: to find an MSO transduction that constructs from a pp-cograph a defining term. Such a transduction exists for countable cographs given with an auxiliary linear order [3, 9]. Such an auxiliary order would be useful, even perhaps necessary.

Problem 6.3 : Determine the set of bounds of **IBO**.

We have presently no result similar to Theorem 5.4 because ternary structures do not share certain good properties of graphs, as we now explain.

First we observe that, since we have an effective MSO characterization of the finite structures in **IBO** by Theorem 4.2(1), hence, we have one of their bounds, among finite ternary structures because the proof for graphs (Proposition 5.3) extends to relational structures.

The proof of Theorem 5.4 uses the fact that the bounds of probe cographs have clique-width ≤ 8 (even if this upper-bound is overestimated). We miss a corresponding fact for $\text{Bnd}(\mathbf{IBO})$. First because there is no really convenient notion of clique-width for ternary structures. However, if we replace the property "the graphs of \mathcal{C} have clique-width at most k " by "the structures of \mathcal{C} are all in $\tau(\mathbf{Trees})$ for some MSO transduction τ " where **Trees** is the class of finite rooted trees, we say that \mathcal{C} is *tree-definable*. In that case, the computability results for graphs of bounded clique-width hold for tree-definable classes of structures. We recall that bounded clique-width is equivalent for a class of graphs to tree-definability ([10], Chapter 7).

The upper-bound 8 to the clique-width of the graphs in $\text{Bnd}(\mathbf{p-cographs})$ given in Proposition 5.3 is based on a lemma that does not extend to ternary structures, as we now prove.

For a set \mathcal{C} of structures (of a fixed signature $\mathcal{R} = \{R_1, \dots, R_p\}$), we let \mathcal{C}^+ be the set of structures $S = (N, R_1, \dots, R_p)$ such that $S[N - x]$ is in \mathcal{C} for some x in N . If \mathcal{C} is a set of graphs of clique-width at most k , then the graphs in \mathcal{C}^+ have clique-width at most $2k$. However, this fact does not extend to tree-definable classes of structures as we now prove. Hence, we cannot extend Theorem 5.4 to the computation of $\text{Bnd}(\mathbf{IBO})$.

Proposition 6.4 : There is a tree-definable set of ternary structures $\mathcal{C} \subseteq$

IBO such that \mathcal{C}^+ is not tree-definable.

Proof : We will use results from [10]. Let $S_G = ([n], B_G)$ where B_G consists of the triples $(1, i, j)$ and $(j, i, 1)$ for the edges $i - j$ of some graph $G = (\{2, 3, \dots, n\}, E)$ and $i < j$. Then S_G is a ternary structure that satisfies Properties A1-A6. It is in \mathcal{C}^+ where \mathcal{C} is the set of trivial ternary structures $(\{2, 3, \dots, n\}, \emptyset)$, obviously in **IBO**. There is an MSO transduction θ that transforms each structure S_G into G : it deletes 1 and replaces the triples $(1, i, j)$ and $(j, i, 1)$ in B_G by (i, j) and (j, i) , thus defining E .

It is clear that \mathcal{C} is tree-definable. If \mathcal{C}^+ would be, that is, if $\mathcal{C}^+ \subseteq \tau(\mathbf{Trees})$ for some MSO-transduction τ , then the MSO-transduction $\theta \circ \tau$ would produce all finite graphs from **Trees** (up to isomorphism), hence, all graphs would have clique-width bounded by a fixed value, which is false. \square

References

- [1] M. Changat, P. Narasimha-Shenoi, and G. Seethakuttyamma, Betweenness in graphs: A short survey on shortest and induced path betweenness, *AKCE International Journal of Graphs and Combinatorics*, **16** (2019) 96-109. (Available on ScienceDirect.com, <https://doi.org/10.1016/j.akcej.2018.06.007>)
- [2] V. Chvatal, Antimatroids, betweenness, convexity, in *Research Trends in Combinatorial Optimization*, Springer, 2008, pp. 57-64.
- [3] B. Courcelle, The monadic second-order logic of graphs X: Linear orderings. *Theor. Comput. Sci.* **160** (1996) 87-143.
- [4] B. Courcelle, Several notions of rank-width for countable graphs, *J. Comb. Theory, Ser. B.* **123** (2017) 186-214.
- [5] B. Courcelle, Algebraic and logical descriptions of generalized trees, *Logical Methods in Computer Science* **13** (2017) Issue 3.
- [6] B. Courcelle, Betweenness in order-theoretic trees, in *Fields of Logic and Computation III, Lec. Notes Comp. Sci.* **12180** (2020) 79-94.
- [7] B. Courcelle, Axiomatizations of betweenness in order-theoretic trees, *Logical Methods in Computer Science* **17** (2021) Issue 1, pp. 11:1-11-42.
- [8] B. Courcelle, Betweenness of partial orders, *Theoretical Informatics and Applications*, **54** (2020), see <https://www.rairo-ita.org/articles/ita/abs/2020/01/ita200028/ita200028.html>.
- [9] B. Courcelle and C. Delhommé, The modular decomposition of countable graphs. Definition and construction in monadic second-order logic. *Theor. Comput. Sci.* **394** (2008) 1-38.
- [10] B. Courcelle and J. Engelfriet, *Graph structure and monadic second-order logic, a language theoretic approach*, Cambridge University Press, 2012.

- [11] J. Daligault, M. Rao and S. Thomassé, Well-quasi-order of relabel functions. *Order* **27** (2010) 301-315.
- [12] I. Durand and M.Raskin, On line software TRAG, see <http://trag.labri.fr>
- [13] R. Fraïssé, *Theory of relations, Studies in Logic*, Volume **145**, North-Holland, 2000.
- [14] F. Gurski, The behaviour of clique-width under graph operations and graph transformations. *Theory Comput. Syst.* **60** (2017) 346-376.
- [15] M. Heule and S. Szeider, A SAT approach to clique-width. *ACM Trans. Comput. Log.* **16** (2015), 24:1-24:27.
- [16] V. B. Le and H. de Ridder, Characterisations and linear-time recognition of probe cographs. *Graph-Theoretic Concepts in Computer Science*, (WG 2007), *Lecture Notes in Computer Science* **4769** (2007) 226-237.
- [17] J. Lihova, Strict-order betweenness, *Acta Univ. M. Belii Ser. Math.* **8** (2000) 27-33. Available from <https://actamath.savbb.sk/acta0804.shtml>.
- [18] M. Pouzet, Un bel ordre d'abritement et ses rapports avec les bornes d'une multirelation, *Comptes Rendus Académie des Sciences, Série A*, **274** (1972) 1677-1680.
- [19] Wikipedia, Cographs, <https://en.wikipedia.org/wiki/Cograph>