



HAL
open science

Optimal Efficiency Control of Synchronous Reluctance Motors-based ANN Considering Cross Magnetic Saturation and Iron Loss

Phuoc Hoa Truong, Damien Flieller, Ngac Ky Nguyen, Jean Merckle

► **To cite this version:**

Phuoc Hoa Truong, Damien Flieller, Ngac Ky Nguyen, Jean Merckle. Optimal Efficiency Control of Synchronous Reluctance Motors-based ANN Considering Cross Magnetic Saturation and Iron Loss. Conférence IECON 2015 (41st Annual Conference of the IEEE Industrial Electronics Society), Nov 2015, Yokohama, Japan. pp.6. hal-03170487

HAL Id: hal-03170487

<https://hal.science/hal-03170487>

Submitted on 16 Mar 2021

HAL is a multi-disciplinary open access archive for the deposit and dissemination of scientific research documents, whether they are published or not. The documents may come from teaching and research institutions in France or abroad, or from public or private research centers.

L'archive ouverte pluridisciplinaire **HAL**, est destinée au dépôt et à la diffusion de documents scientifiques de niveau recherche, publiés ou non, émanant des établissements d'enseignement et de recherche français ou étrangers, des laboratoires publics ou privés.

Optimal Efficiency Control of Synchronous Reluctance Motors-based ANN Considering Cross Magnetic Saturation and Iron Loss

Phuoc Hoa Truong¹, Damien Flieller², Ngac Ky Nguyen³, Jean Merckle¹

¹ MIPS Laboratory - University of Haute Alsace, 4 Rue des Frères Lumière, 68093 Mulhouse - France.
[phuoc-hoa.truong, jean.merckle]@uha.fr

² GREEN Laboratory - INSA de Strasbourg, 24 Boulevard de la Victoire, 67084 Strasbourg - France.
damien.flieller@insa-strasbourg.fr

³ L2EP Laboratory –Arts et Métiers ParisTech – CER de Lille, 8 Boulevard Louis XIV, 59046 Lille- France.
NgacKy.NGUYEN@ensam.eu

Abstract— This paper presents a new idea by using the Artificial Neural Networks (ANNs) for estimating the parameters of the machine which achieving the maximum efficiency of the Synchronous Reluctance Motor (SynRM). This model take into consideration the magnetic saturation, cross-coupling and iron loss. With Finite Element Analysis (FEA), the characteristics of the SynRM including inductances and iron loss resistance are determined. Because of the non-linear characteristics, an ANN trained off-line, is then proposed to obtain the d-q inductances and iron loss resistance from I_d, I_q currents and the speed. After learning process, an analytical expression of the optimal currents is given thanks to Lagrange optimization. Therefore, the optimal currents will be obtained online in real time. This method can be achieved with maximum efficiency and high-precision torque control. Simulation and experimental results are presented to confirm the validity of the proposed method.

Index Terms— Synchronous Reluctance Motor, Optimal Efficiency, Finite Element Analysis, Optimal Currents, Lagrange Optimization, Artificial Neural Networks.

I. INTRODUCTION

Synchronous reluctance motor (SynRM) has received much attention for many applications in recent years due to its simplicity of structure, low manufacturing cost and rugged construction [1-2]. Many authors proposed different methods for improving the efficiency this kind of machine. In general, two major approaches can be identified.

The first one uses a search algorithm and is called search controller (SC) method [3-4]. The electrical input power is measured and minimized by different algorithms. The authors in [3] proposed a method for optimum-efficiency controller of a SynRM drive by adding a small amount of perturbation to the d-axis current reference for the purpose of searching a minimum input power. However, the convergence of this method is very low and there is torque ripple in steady state. The works presented in [4] minimizes the input power with a search controller using Fibonacci search algorithm. It searches the optimal reference value of the d-axis stator current for which the input power is minimum. The optimal efficiency

maybe not reached if the initial working point is far from the optimal point.

The second approach, called loss model controller (LMC), is based on a loss model of the motor [5-16]. The optimal currents are generated from the equations of the machine losses. This approach is more often used in industrial drive systems because of the control stability and current pulsation reduction [13]. In [6-7], the loss-model are introduced for determining the optimal d-axis component of the stator current which minimizing the power losses. Based on input-output linearization, the authors in [8-9] proposed the methods to obtain the constant torque and minimize the losses. However, this method contain the drawback including complexity in real-time constraints. In [10], an ANN was trained online to map the optimal current ratio and an extended Kalman filter in [11] is proposed by the authors to estimate the parameter of the SynRM in order to achieve the optimal efficiency of this kind this machine. In [12], a high-efficiency control based on fuzzy logic is reported. However, the fuzzy logic control requires the experiences of the designer.

This paper presents an investigation of Artificial Neural Networks (ANNs) for optimal efficiency control of Synchronous Reluctance Motors including magnetic saturation, cross-coupling and iron loss. The proposed method can determine the optimal d- and q-axis currents quickly thanks to Lagrange optimization. This method is capable of both maximum efficiency and also realize high-precision torque control. An ANN is proposed to estimate the d-q inductances and iron loss resistance which deriving the maximum efficiency immediately. With an ANN, we can improve the accuracy of the parameters estimation when using an approximation integrator in [13]. Moreover, it can be replace the look-up table in [14] to reduce the large memory space when the database of the machine parameters is very large. The comparisons of the efficiency between the conventional and the proposed method are presented by the simulation and experimental results to confirm the validity of the proposed method.

This paper is organized as follows: The Lagrange optimization to obtain the optimal currents is presented in Section II. Section III presents the investigation of ANN for the parameters estimation. Simulation and experimental results are shown in Section IV and V respectively. Finally, the conclusions are given in Section VI.

II. OPTIMAL CURRENTS BASED ON LAGRANGE OPTIMIZATION

In the rotating reference frame, the d and q-axes equivalent circuits of the SynRM considering the iron loss is shown in Fig. 1 [8], [11].

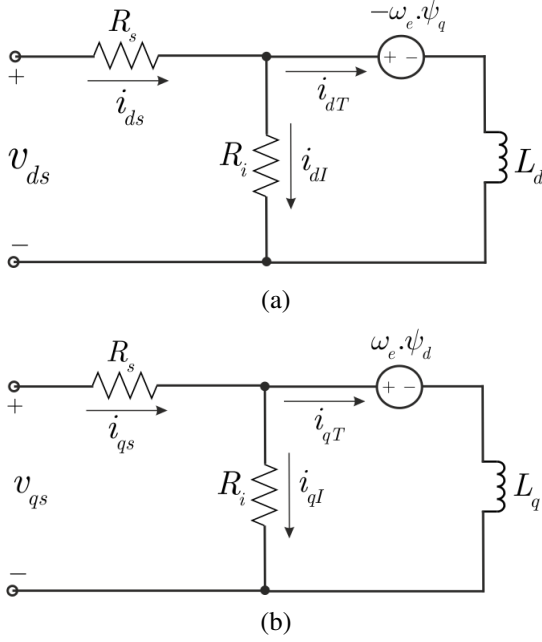

Fig. 1. Equivalent circuits of the SynRM considering the iron loss

(a) d-axis (b) q-axis

The electromagnetic torque is expressed as:

$$T_e = \frac{3}{2} \cdot p \cdot (L_d - L_q) \cdot i_{dT} \cdot i_{qT} \quad (1)$$

or
$$T_e = J_m \cdot \frac{d\omega_m}{dt} + B_m \cdot \omega_m + T_L$$

where L_d and L_q represent d and q- axes inductances

p : the number of pole pairs.

T_L : the load torque, J_m : the load inertia, B_m : the viscous friction, and ω_m : the mechanical speed.

From Fig. 1, the armature currents (i_{ds} , i_{qs}) and the iron loss currents (i_{dI} , i_{qI}) can be given as:

$$\begin{cases} i_{ds} = i_{dI} + i_{dT} \\ i_{qs} = i_{qI} + i_{qT} \end{cases} \quad (2)$$

In the steady state, the currents can be expressed as:

$$\begin{cases} i_{dT} = \frac{-\omega_e}{R_i} \cdot \Psi_q \\ i_{qI} = \frac{\omega_e}{R_i} \cdot \Psi_d \end{cases} \quad (3)$$

where ω_e : rotational speed, R_i : iron loss resistance

Ψ_d and Ψ_q denote the d- and q-axes flux linkages as:

$$\begin{cases} \Psi_d = L_d \cdot i_{dT} \\ \Psi_q = L_q \cdot i_{qT} \end{cases} \quad (4)$$

Replacing (Ψ_d , Ψ_q) from (4) in (3), we obtain (5):

$$\begin{cases} i_{dT} = \frac{R_i \cdot i_{qI}}{\omega_e \cdot L_d} \\ i_{qT} = \frac{-R_i \cdot i_{dI}}{\omega_e \cdot L_q} \end{cases} \quad (5)$$

The copper loss P_c and iron losses P_i of the SynRM can be calculated as (6) and (7), respectively :

$$P_c = \frac{3}{2} \cdot R_s \cdot (i_{ds}^2 + i_{qs}^2) \quad (6)$$

$$P_i = \frac{3}{2} \cdot R_i \cdot (i_{dI}^2 + i_{qI}^2) \quad (7)$$

Thus, the total power losses P_L of the SynRM can be expressed as:

$$P_L = \frac{3}{2} \cdot R_s \cdot (i_{ds}^2 + i_{qs}^2) + \frac{3}{2} \cdot R_i \cdot (i_{dI}^2 + i_{qI}^2) \quad (8)$$

In order to obtain the desired electromagnetic torque and minimize the total power losses P_L , the Lagrange's optimization is define as:

$$\begin{aligned} L = & \frac{3}{2} \cdot R_s \cdot (i_{ds}^2 + i_{qs}^2) + \frac{3}{2} \cdot R_i \cdot (i_{dI}^2 + i_{qI}^2) + \\ & + \lambda (T_e - \frac{3}{2} \cdot p \cdot (L_d - L_q) \cdot i_{dT} \cdot i_{qT}) \end{aligned} \quad (9)$$

with λ : Lagrange's multiplier.

Replacing (i_{ds} , i_{qs}) and (i_{dT} , i_{qT}) from (2), (5) in (9) and

derivations of L according to i_{dI} , i_{qI} respectively, we obtain the optimal currents as (10), (11) and (12) :

$$\begin{cases} i_{dI_opt} = \frac{C}{\sqrt[4]{\frac{B}{A}}}, i_{qI_opt} = \sqrt[4]{\frac{B}{A}} \\ i_{dT_opt} = D \cdot \sqrt[4]{\frac{B}{A}}, i_{qT_opt} = \frac{E \cdot C}{\sqrt[4]{\frac{B}{A}}} \end{cases} \quad (10)$$

$$\begin{cases} i_{dI_opt} = D \cdot \sqrt[4]{\frac{B}{A}}, i_{qT_opt} = \frac{E \cdot C}{\sqrt[4]{\frac{B}{A}}} \end{cases} \quad (11)$$

$$\begin{cases} i_{ds_ref} = i_{ds_opt} = D \cdot \sqrt[4]{\frac{B}{A}} + \frac{C}{\sqrt[4]{\frac{B}{A}}} \\ i_{qs_ref} = i_{qs_opt} = \frac{E \cdot C}{\sqrt[4]{\frac{B}{A}}} + \sqrt[4]{\frac{B}{A}} \end{cases} \quad (12)$$

$$\text{with } A = \frac{3}{2} \cdot (R_s \cdot \frac{R_i^2}{\omega_e^2 \cdot L_d^2} + R_s + R_i)$$

$$B = \frac{2}{3} \cdot (\frac{T_e \cdot \omega_e^2 \cdot L_d \cdot L_q}{p \cdot (L_d - L_q) \cdot R_i^2})^2 (R_s \cdot \frac{R_i^2}{\omega_e^2 \cdot L_d^2} + R_s + R_i)$$

$$C = -\frac{2 \cdot T_e \cdot \omega_e^2 \cdot L_d \cdot L_q}{3 \cdot p \cdot (L_d - L_q) \cdot R_i^2}, \quad D = \frac{R_i}{\omega_e \cdot L_d}, \quad E = \frac{-R_i}{\omega_e \cdot L_q}$$

Finally, three phase optimal currents will be obtained by:

$$\begin{bmatrix} i_{a_opt} \\ i_{b_opt} \\ i_{c_opt} \end{bmatrix} = \mathbf{P}(p\theta) \cdot \begin{bmatrix} i_{ds_opt} \\ i_{qs_opt} \end{bmatrix} \quad (13)$$

where $\mathbf{P}(p\theta)$: Park's transformation is defined as

$$\mathbf{P}(p\theta) = \sqrt{\frac{2}{3}} \cdot \begin{bmatrix} \cos(p\theta) & -\sin(p\theta) \\ \cos(p\theta - \frac{2\pi}{3}) & -\sin(p\theta - \frac{2\pi}{3}) \\ \cos(p\theta + \frac{2\pi}{3}) & -\sin(p\theta + \frac{2\pi}{3}) \end{bmatrix} \quad (14)$$

The output power P_{out} and the efficiency of the SynRM drive η are expressed as:

$$\eta = \frac{P_{out}}{P_{out} + P_L} \cdot 100\% \quad (15)$$

III. INVESTIGATION OF ARTIFICIAL NEURAL NETWORKS FOR THE PARAMETERS ESTIMATION

This section presents the investigation of Artificial Neural Networks to estimate the parameters L_d, L_q, R_i of the SynRM including magnetic saturation and cross-coupling.

Fig. 2 shows the meshed FEA model of the studied SynRM when using JMAG software in order to calculate the parameters of the machine. The inductances L_d, L_q and iron loss resistance R_i obtained with FEA is shown in Fig. 3. As can be seen, when the currents i_{ds} and i_{qs} increase, the inductance L_d, L_q will be decreased because of the magnetic saturation and cross-coupling [13], [15]. Fig 3c shows the influence of the iron loss resistance by the current i_{ds} and the speed [8].

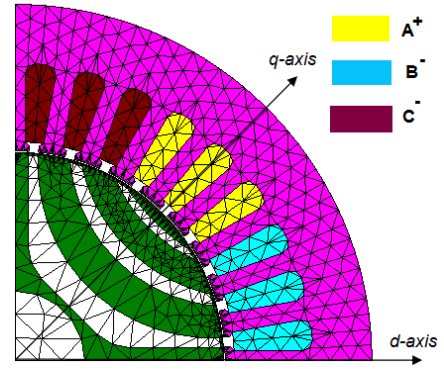

Fig. 2. Meshed FEA model of the studied SynRM by JMAG (a)

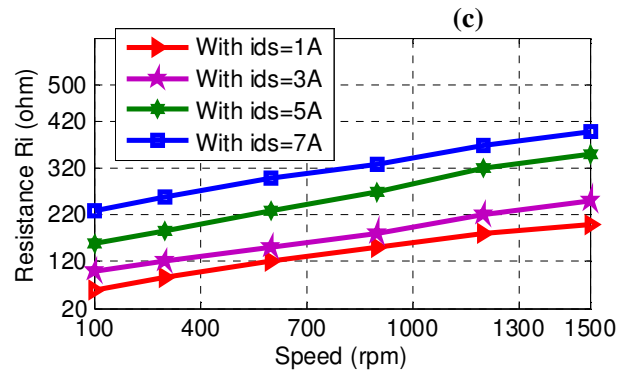
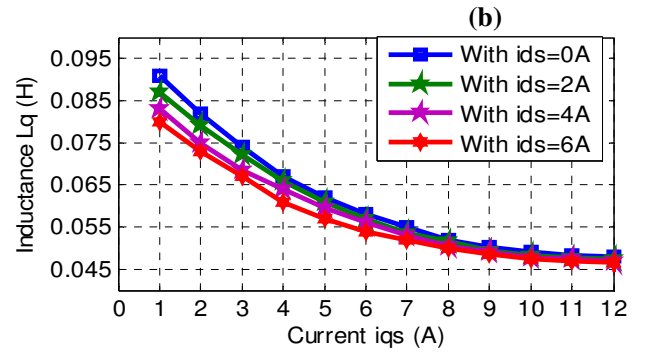
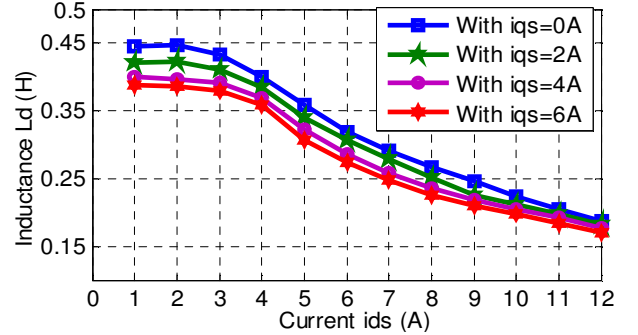

Fig. 3. Parameters of the machine obtained with FEA

(a) Inductance L_d (b) Inductance L_q (c) Iron loss resistance R_i

The parameters of the machine including L_d, L_q, R_i obtained from FEA were used to train the Neural Network is shown in the Fig.4. This ANN include 3 inputs i_{ds}, i_{qs}, ω_r and 3 outputs $L_{d_es}, L_{q_es}, R_{i_es}$.

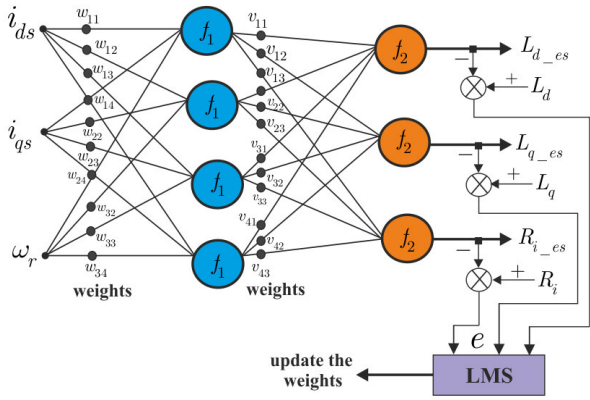

Fig. 4. Neural Networks to estimate L_d, L_q, R_i

A two-layer network is used for implementing this net. The training algorithm is Levenberg –Marquardt with *trainlm* function. The squared error acceptable for training is 10^{-4} .

Number of neurons of the 1st layer is 4 *logsig* neurons. The 2nd layer has 3 *purelin* neurons. So, the total number of neurons is 7. The weights of the ANN are updated using an iterative linear LMS (Least Mean Square) algorithm [17] in order to minimize the error between the actual value L_d, L_q, R_i and the estimated value $L_{d_es}, L_{q_es}, R_{i_es}$. The weights w or v are adjusted according to:

$$w(k+1) = w(k) + \eta \cdot e(k) \cdot x_i(k) \quad (16)$$

where x is the input vector (i_{ds}, i_{qs}, ω_r), η is a learning rate, e is the error between the actual value L_d, L_q, R_i and the estimated value $L_{d_es}, L_{q_es}, R_{i_es}$.

IV. SIMULATION OF THE PROPOSED METHOD

To confirm the validity of the proposed method in the previous sections, a Matlab/Simulink program is used to simulate. The optimal efficiency control of the SynRM with parameters estimation by ANN is presented in Fig. 5. The parameters of the machine for simulation and experimental results are shown in Table I. In this simulation, the reference speed is fixed at 500 (rpm). By changing the load torque, the currents in d-q-axes has been changed. The parameters of the machine will be estimated by ANN to achieve with maximum efficiency.

Table I. Parameters of the SynRM under simulation and experimental test

Rated power: $P=1.1$ (Kw)	$J_m = 0.002(kgm^2)$,
Rated current: $I_{n-rms} = 3A$	Pole pairs number: $p=2$
Resistance: $R_s = 6.2(\Omega)$	Rated torque: $T_N = 7(N.m)$
Rated speed: 1500 (rpm)	

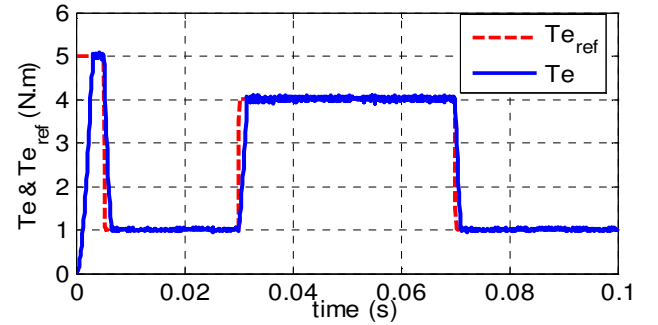

Fig. 6. Electromagnetic torque T_{e_ref} and T_e

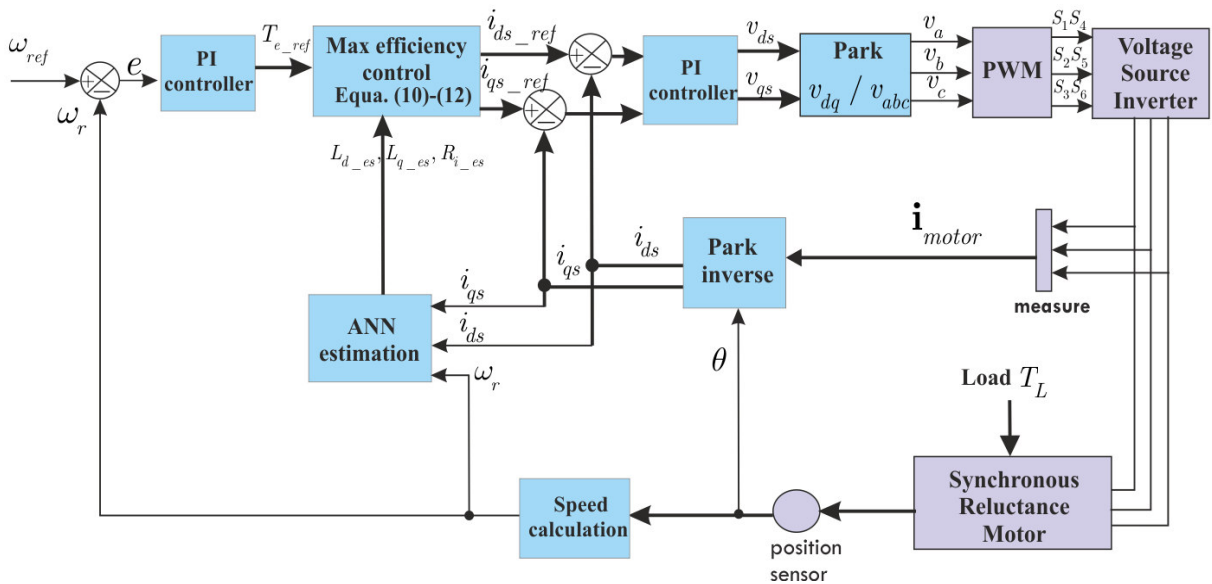

Fig. 5. Optimal efficiency control of SynRM with parameters estimation by ANN

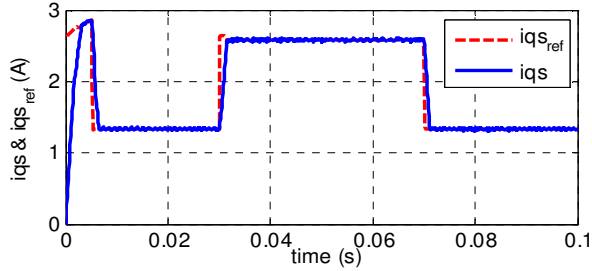
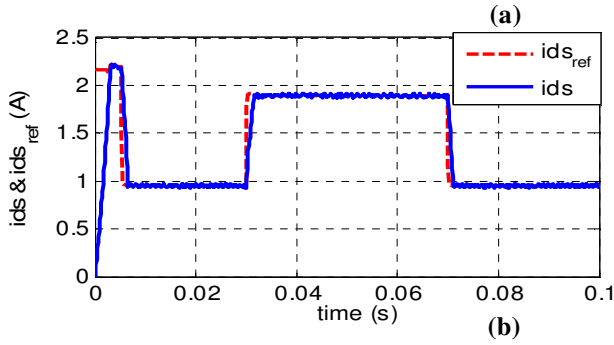

Fig. 7. Optimal currents i_{ds}, i_{qs}

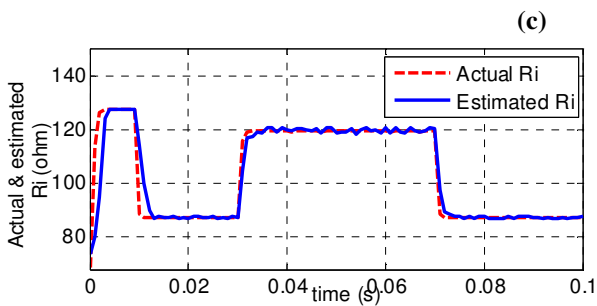
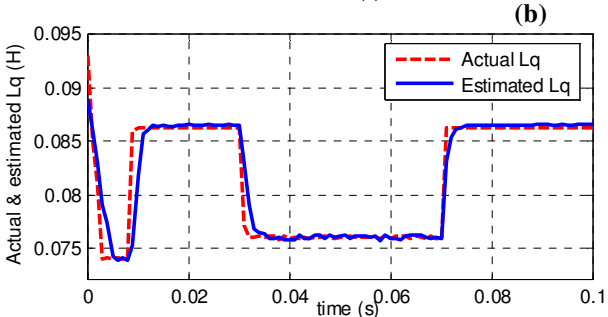
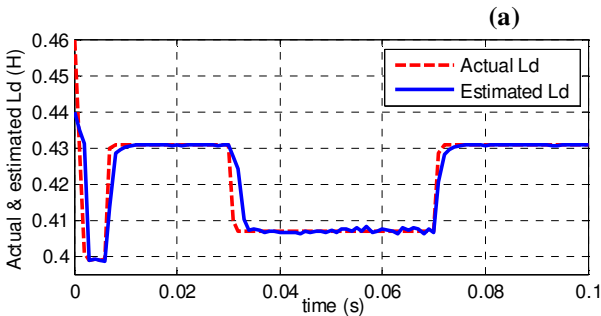

Fig. 8. Parameters estimated by ANN
(a) Inductance L_d (b) Inductance L_q (c) Resistance R_i

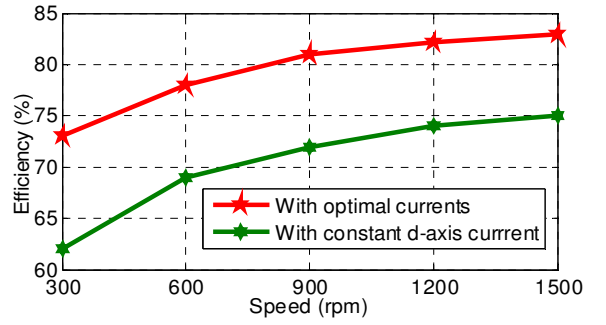

Fig. 9. Efficiency comparison of the proposed with conventional method

Fig. 6 and Fig. 7 show the electromagnetic torque and optimal currents i_{ds}, i_{qs} respectively with the proposed method. We can observe that the torque and the optimal currents are good regulation.

Fig. 8 is showing the parameters of the machine including L_d, L_q, R_i estimated by ANN. As can be seen, the estimated inductances and the resistance iron loss converge to real values within a short time. The accurate of the parameters estimation is important to achieve maximum efficiency of the machine.

The efficiency comparison at rated load between the proposed and the conventional method (constant d-axis current) is shown in Fig. 9. As can be seen, the efficiency of the proposed method at rated speed is around 83% while the efficiency of conventional one is around 75%. It is obvious that the efficiency when using the optimal currents is superior than the conventional method [8], [11].

In next section, the experimental results will be presented to confirm the validity of the proposed method.

V. EXPERIMENTAL RESULTS

The experimental platform is shown in Fig. 10. A three phase machine SynRM is connected to a three-phase voltage source inverter. The machine parameters are given in Table I. The rotor's position and the stator currents are measured in real time by using an incremental coder and currents sensors thought by the DSPACE 1104. The ANN Controller has been implemented using kit DSPACE 1104 with Matlab/Simulink.

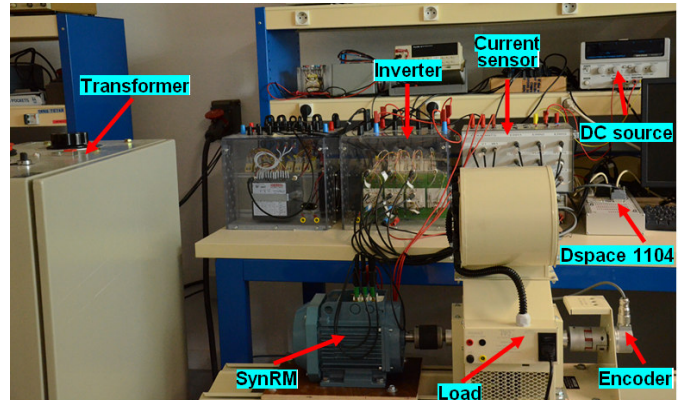

Fig. 10. Experimental platform setup

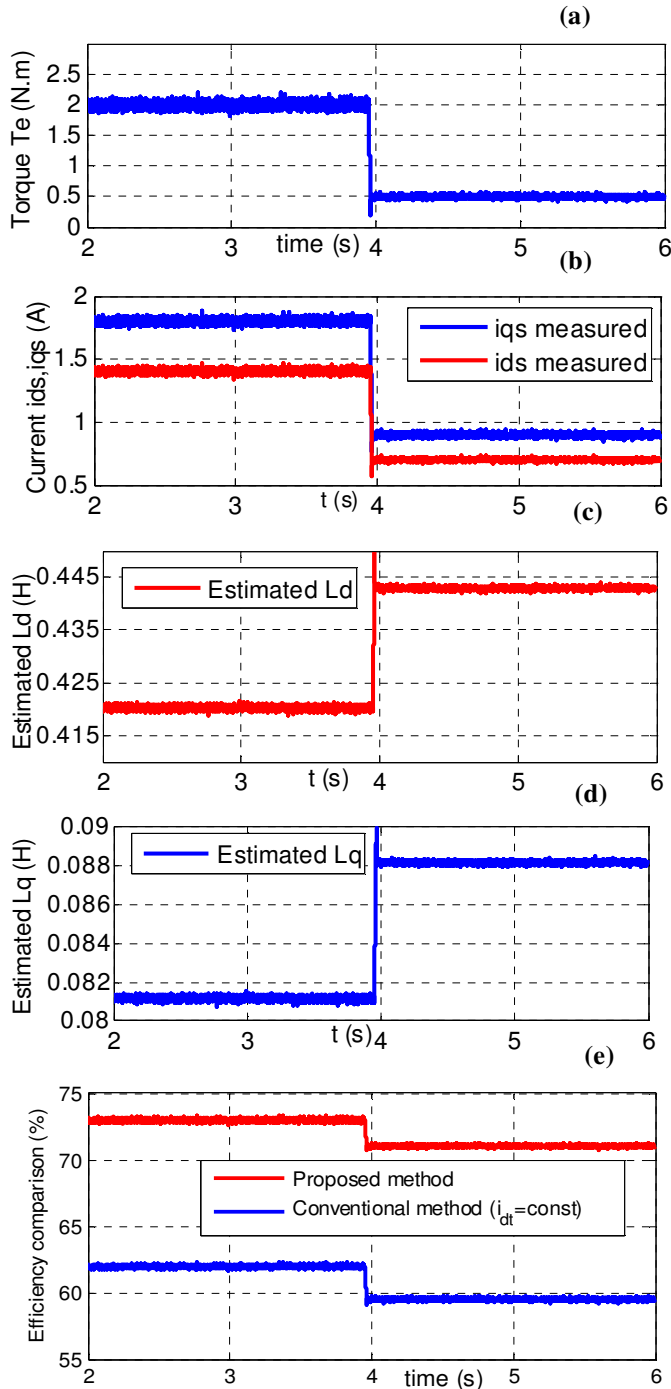

Fig. 11. Experimental results at $\omega_r = 70(\text{rad/s})$

Fig.11 shows the experimental results of the proposed method at $\omega_r = 70(\text{rad/s})$. We can observe that the good convergence of the ANN for estimating the parameters of the machine and the efficiency of the proposed method is higher about 10% with the conventional one.

VI. CONCLUSIONS

A new idea by using the ANN for estimating the parameters of the machine which can replace an approximation integrator or the look-up table is proposed in this paper. With the proposed method, the optimal currents

will be obtained online in real time which helping to achieve the maximum efficiency and high-precision torque control. The simulation and experimental results clearly show that the efficiency when using the optimal currents is superior than the conventional method. Furthermore, the ANN shows the accurate of the parameters estimation.

REFERENCES

- [1] S. Taghavi and P. Pillay, "A Sizing Methodology of the Synchronous Reluctance Motor for Traction Applications," *IEEE Journal of Emerging and Selected Topics in Power Electronics*, vol. 2, pp. 329-340, 2014.
- [2] M. Ferrari, *et al.*, "Design of Synchronous Reluctance Motor for Hybrid Electric Vehicles," *IEEE Transactions on Industry Applications* vol. PP, pp. 1-1, 2015.
- [3] T. Matsuo, A. El-Antably and T. A. Lipo, "A new control strategy for optimum-efficiency operation of a synchronous reluctance motor," *IEEE Transactions on Industry Applications*, vol. 33, pp. 1146-1153, 1997.
- [4] T. Lubin, H. Razik and A. Rezzoug, "On-line efficiency optimization of a synchronous reluctance motor," *Electric Power Systems Research*, vol. 77, pp. 484-493, 2007.
- [5] H. F. Hofmann, S. R. Sanders and A.El-Antably, "Stator-flux-oriented vector control of synchronous reluctance Machines with maximized efficiency," *IEEE Transactions on Industrial Electronics*, vol. 51, pp. 1066-1072, 2004.
- [6] I. Kioskeridis and C. Mademlis, "Energy efficiency optimisation in synchronous reluctance motor drives," *IEE Proceedings Electric Power Applications*, vol. 150, pp. 201-209, 2003.
- [7] C. Mademlis, I. Kioskeridis and N. Margaris, "Optimal efficiency control strategy for interior permanent-magnet synchronous motor drives," *IEEE Transactions on Energy Conversion* vol. 19, pp. 715-723, 2004.
- [8] L. Hyeoun-Dong, K. Seog-Joo and S. Seung-Ki, "Efficiency-optimized direct torque control of synchronous reluctance motor using feedback linearization," *IEEE Transactions on Industrial Electronics* vol. 46, pp. 192-198, 1999.
- [9] H. Abootorabi Zarchi, J.Soltani and G.A. Markadeh "Adaptive Input-Output Feedback-Linearization-Based Torque Control of Synchronous Reluctance Motor Without Mechanical Sensor," *IEEE Transactions on Industrial Electronics* vol. 57, pp. 375-384, 2010.
- [10] T. Senjyu, T. Shingaki and K. Uezato, "A novel high efficiency drive strategy for synchronous reluctance motors considering iron loss using neural network," *16th Annual IEEE Applied Power Electronics Conference*, vol. 2, pp. 1090-1095, 2001.
- [11] T. Senjyu, *et al.*, "High efficiency control of synchronous reluctance motors using extended Kalman filter," *IEEE Transactions on Industrial Electronics*, vol. 50, pp. 726-732, 2003.
- [12] M. N. Uddin and J. Khastoo, "Fuzzy Logic-Based Efficiency Optimization and High Dynamic Performance of IPMSM Drive System in Both Transient and Steady-State Conditions," *IEEE Transactions on Industry Applications*, vol. 50, pp. 4251-4259, 2014.
- [13] S. Yamamoto, *et al.*, "Maximum Efficiency Drives of Synchronous Reluctance Motors by a Novel Loss Minimization Controller With Inductance Estimator," *IEEE Transactions on Industry Applications*, vol. 49, pp. 2543-2551, 2013.
- [14] H. Aorith, *et al.*, "A new Loss Minimization Algorithm for Interior Permanent Magnet Synchronous Machine drives," *IEEE International Electric Machines & Drives Conference (IEMDC)*, pp. 526-533, 12-15 May 2013.
- [15] Q. Zengcai, *et al.*, "Minimizing losses of a synchronous reluctance motor drive taking into account core losses and magnetic saturation," *16th European Conference on Power Electronics and Applications (EPE'14)* pp. 1-10, 26-28 Aug 2014.
- [16] N. Ronggang, *et al.*, "Maximum Efficiency Per Ampere Control of Permanent-Magnet Synchronous Machines," *IEEE Transactions on Industrial Electronics*, vol. 62, pp. 2135-2143, 2015.
- [17] B. Widrow and E. Walach, *Adaptive Inverse Control*. Prentice-Hall, 1996.