



**HAL**  
open science

# A multi-objective optimization model to plan city-scale water systems with economic and environmental objectives: a case study in Santiago, Chile

Daniela Gormaz-Cuevas, Javiera Riffo-Rivas, Ludovic Montastruc, Mariana Brüning-González, Felipe A. Díaz-Alvarado

## ► To cite this version:

Daniela Gormaz-Cuevas, Javiera Riffo-Rivas, Ludovic Montastruc, Mariana Brüning-González, Felipe A. Díaz-Alvarado. A multi-objective optimization model to plan city-scale water systems with economic and environmental objectives: a case study in Santiago, Chile. *Journal of Cleaner Production*, 2021, 279, pp.123737. 10.1016/j.jclepro.2020.123737 . hal-03159940

**HAL Id: hal-03159940**

**<https://hal.science/hal-03159940>**

Submitted on 4 Mar 2021

**HAL** is a multi-disciplinary open access archive for the deposit and dissemination of scientific research documents, whether they are published or not. The documents may come from teaching and research institutions in France or abroad, or from public or private research centers.

L'archive ouverte pluridisciplinaire **HAL**, est destinée au dépôt et à la diffusion de documents scientifiques de niveau recherche, publiés ou non, émanant des établissements d'enseignement et de recherche français ou étrangers, des laboratoires publics ou privés.



## Open Archive Toulouse Archive Ouverte


OATAO is an open access repository that collects the work of Toulouse researchers and makes it freely available over the web where possible

This is an author's version published in: <https://oatao.univ-toulouse.fr/27119>

### Official URL:

<https://doi.org/10.1016/j.jclepro.2020.123737>

### To cite this version:

Gormaz-Cuevas, Daniela and Riffo-Rivas, Javiera and Montastruc, Ludovic  and Brüning-González, Mariana and Díaz-Alvarado, Felipe A. *A multi-objective optimization model to plan city-scale water systems with economic and environmental objectives: a case study in Santiago, Chile.* (2021) Journal of Cleaner Production, 279. 123737. ISSN 0959-6526 .

Any correspondence concerning this service should be sent to the repository administrator: [tech-oatao@listes-diff.inp-toulouse.fr](mailto:tech-oatao@listes-diff.inp-toulouse.fr)

# A multi-objective optimization model to plan city-scale water systems with economic and environmental objectives: A case study in Santiago, Chile

Daniela Gormaz-Cuevas<sup>a</sup>, Javiera Riffo-Rivas<sup>a</sup>, Ludovic Montastruc<sup>b</sup>,  
Mariana Brüning-González<sup>a</sup>, Felipe A. Díaz-Alvarado<sup>a,\*</sup>

<sup>a</sup> Department of Chemical Engineering, Biotechnology, and Materials, Faculty of Physical and Mathematical Sciences, Universidad de Chile, Av. Beauchef 851, Piso 6-poniente, Group of Sustainable Design and Process Systems Engineering, 8370456, Santiago, Chile

<sup>b</sup> Université de Toulouse, Laboratoire de Génie Chimique U.M.R. 5503 CNRS/INP/UPS. 4 Allée Emile Monso, 31432, Toulouse Cedex 4, France

## A B S T R A C T

Climate Change and its effects in water scarcity has become an important challenge for cities with water management problems. These problems require an integral planning of the city, which can be supported by optimization. The main goal of the research is to provide a regional optimization model for water networks, including new treatment options. The model is formulated as a multi objective mixed integer programming problem, focused on environmental and economic impact of the network, minimizing water extracted from natural sources and total cost. The formulation is developed with the goal programming methodology. The model covers a complete existing city scale water network, including 4 different options of water reuse within the city: drinking water, fresh water, irrigation, and discharge in natural courses. The case study is Santiago, capital of Chile, which is the political, economic, and institutional center of Chile. If both objective functions have equal importance to configure the solution, the following ideas characterize the optimal water network: (i) it is more environmentally and economically convenient to reuse water within the network rather than recycling water to the natural source; (ii) the reuse of water is preferred in the form of irrigation and drinking qualities rather than industrial qualities to reduce transport costs, and (iii) the modification of the current treatment plants is preferred, because of the high cost of installation of new plants. An environmental and cost effective solution for Santiago, Chile, can reduce the source water extraction in 35.7%. The model can be implemented in other contexts, providing orientations to decision makers so as to plan city scale water networks with simultaneous environmental and economic considerations.

### Keywords:

Water networks  
Regional integration  
Multi-objective optimization

## 1. Introduction

Climate change has become an important issue in several regions worldwide since human behavior is conditioned by the effects of Global Warming on Earth (Santibanez, 2018). A direct effect is water scarcity (Gosling and Arnell, 2013), considered a global risk by the World Economic Forum affecting two thirds of the world's population (Van Der Heijden, K and Stinson, C, 2019). To address this issue, long term planning of city scale water systems has become a key matter. Therefore, water management and planning

under uncertainty has been a priority area of research aiming at improving large scale regional water systems (Vucetic and Simonovic, 2011). In this context, optimization techniques can be a valuable tool for water resource management in order to redesign regional water systems. This topic constitutes the main focus of this project.

Some efforts have previously been made to model and optimize both Industrial Water Networks (IWN) and water networks within Eco Industrial Parks (EIP), having environmental and economic benefits.

Campos de Faria et al. (2009) looked for the minimum operational cost and fresh water consumption of an IWN. The results showed that it is useful to identify reuse opportunities. Boix et al. (2012) developed a multi objective optimization model of an EIP

\* corresponding author.

E-mail address: felidiaz@ing.uchile.cl (F.A. Díaz-Alvarado).

in order to minimize (i) fresh water flow rate at the network entrance; (ii) water flow rate at inlets of regeneration units, and (iii) the number of connections into the network, obtaining that the use of regeneration units yields significant gains. These gains can be increased again by a direct integration into an EIP. These works have motivated the development of similar approaches for synthesizing water networks at the regional level. [Liu et al. \(2011\)](#) developed an optimization model for water resources management for insular areas in Greece. [Rojas Torres et al. \(2015\)](#) proposed a multi objective optimization model to design a water system in a city scale, using water reuse for agricultural purpose. [Pérez et al. \(2017\)](#) also proposed a model to design a water system in a city in Mexico, but using rainwater reservoirs.

Previous research shows that there are efforts focused on different scales. The present paper is focused in city scales.

The objective when redesigning water systems is to improve the use of the resource towards sustainability. With this purpose, incorporating non conventional water sources and the reusing/recycling waste water have an important potential. Many efforts have been made to reuse and recycle water in the industrial sector. The following section presents a Literature review and the novelty of this paper.

## 2. Literature review and novelty of this paper

[Lovelady and El Halwagi \(2009\)](#) developed a model to plan water management among multiple processes in a common EIP facility. [Campos de Faria et al. \(2009\)](#) proposed alternatives to optimize IWN using different regeneration units. [Sadegh et al. \(2011\)](#) presented a model to minimize the energy of an inter plant water network in an EIP. These works include reuse and/or recycle of water within the system.

Some studies refer to the incorporation of new sources and reclaimed water in a city scale optimization model. [Liu et al. \(2011\)](#) presented an optimization approach for water management of a city including desalinated seawater and reclaimed water as water sources. [Rojas Torres et al. \(2015\)](#) incorporated rainwater harvesting and reclaimed water.

The present paper presents a model that allows the recycling of water in the network with 4 different qualities, allowing the supply of different consumers.

It is important to note that most of the studies have been focused on the synthesis problem of different water networks. Other option is to retrofit existing water networks in order to redesign them. This is particularly useful for regional water networks because problem solution must be adapted for existing treatment units and distribution/collection networks.

[Campos de Faria et al. \(2009\)](#) presented a methodology for retrofitting an Industrial Water Network (IWN). [Sotelo Pichardo et al. \(2011\)](#) proposed a mathematical programming model for the optimal retrofitting of an IWN. [Rubio Castro et al. \(2012\)](#) developed a model to design an Eco Industrial Park by retrofitting existing water networks.

As cited above, research with plant modification is mainly applied in IWN. The present paper includes the possibility of installing new plants or retrofitting existing ones, both on a city scale.

To achieve a reduction in pollutants in the water and to achieve the quality required by each user, the use of different treatment technologies is necessary, so studying characteristics such as costs and treatment flows is required.

[Rodríguez Miranda \(2015\)](#) investigated the costs of installation of various technologies of wastewater treatment plants in Cundinamarca, characterizing each one of them and obtaining investment cost functions for each one, when doing an investigation of

the existing projects in the area. [McGivney and Kawamura \(2008\)](#) researched installation and operating costs of various water treatment technologies, including drinking water and wastewater treatment technologies. It also incorporates recycling technologies. [Guo et al. \(2014\)](#) studied the costs and characteristics of water treatment technologies, especially the reuse of water without environmental buffers. The research presents a detailed analysis of the treatment flows and costs of technologies such as activated sludge, membrane bioreactor, coagulation/flocculation, reverse osmosis, among others.

In the present paper, the costs of preliminary studies to establish the objective economic function are incorporated.

Water system modification has different impacts. These impacts have been studied considering mainly economic or environmental dimensions, developing a single objective function. Some authors focused on reducing the associated cost.

[Bagajewicz et al. \(2000\)](#), focused on minimizing the operational and investment cost of a water network problem by using a tree search algorithm; [Liu et al. \(2011\)](#) proposed a MILP problem by minimizing capital and operating costs applied to a city. The capital cost includes the installation of pipelines, pumping stations, storage tanks and treatment plants; while the operating cost includes the cost of pumping water and the cost of operating the treatment plants. Finally, [Rubio Castro et al. \(2012\)](#), proposed a MINLP problem minimizing plant capital and piping operation costs, applied to an eco industrial park, including several application scenarios. These authors demonstrate the value of considering different types of costs in a water network system.

On the other hand, other authors focus on the importance of the environmental impact generated by the water network, from different perspectives. [Boix et al. \(2011\)](#) presents a MINLP problem solved by means of a lexicographic strategy, applied to a industrial water network, where it seeks to minimize the flow of water extraction from natural sources, the flow at the entrance of regeneration units and the number of interconnections within the network. [Mughees et al. \(2013\)](#) seeks to increase the water efficiency of a petrochemical plant by minimizing its water consumption and reusing wastewater through a MINLP problem formulation. Finally, [Hansen et al. \(2018\)](#) also seeks to minimize the water consumption of a petrochemical plant by formulating an NLP problem.

The above mentioned research, shows that there are efforts to minimize both economic and environmental effects. The present investigation attempts to minimize both impacts in the same model.

Simultaneous minimization of environmental and economic impacts is less common, composing a multi objective optimization problem. In particular, [Kantor et al. \(2015\)](#) developed a model to reduce network life cycle emissions while seeking to reduce their cost in an EIP water network. [Rojas Torres et al. \(2015\)](#) proposed a model to solve planning and scheduling water storage and distribution for a city, maximizing overall profit and minimizing fresh water consumption and land use. [Pérez et al. \(2019\)](#) proposed to design an optimal water distribution network maximizing revenues and minimizing both groundwater usage and investment cost.

The present research seeks to reduce the costs of installing water treatment plants and operating the network, and to reduce the flow rate of extraction from natural sources, thus incorporating the economic and environmental impact.

The primary contribution of the present Multi objective optimization model is to decide the installation of new treatment plants and connections within a city scale water network, or the modification of existing plants, by assessing environmental and economic objectives at the same time. Besides previous efforts have been done in the field of Multi objective optimization applied to

water systems, these efforts are concentrated in subparts of the whole system as the distribution network. The present paper include a representation of the distribution network, different sources, and a variety of consumption types and water qualities, so as to model a city scale water system.

There are different methodologies to solve mono and multi objective optimization problems. According to Rangaiah (2017), resolution of multi objective problems can be classified in two types: Generating Methods and Preference Based Methods. The first type generates one or more Pareto optimal solutions without any inputs from the decision maker. On the other hand, preference based methods utilize the preferences specified by the decision maker at some problem solution stage. De León et al. (2016) applied the  $\epsilon$  constraint procedure, included within the method generation, to minimize global economic cost and freshwater consumption. Xevi and Khan (2006) maximized net revenues and minimized costs using Goal programming technique, included within the method preference based Methods. Ghosh et al. (2016) also uses Goal programming to design a cost effective biological treatment process for industrial wastewater. The present investigation uses Goal programming technique to solve the multi objective problem.

None of the previously mentioned investigations present a multi objective optimization problem on a city scale, considering the reuse of 4 different water qualities to supply different consumers. This way of approaching the problem, not considered before, is presented in this study. A novel superstructure is created for modeling a city scale water system in order to plan new treatment plants and connections among stakeholders, taking into account simultaneous economic and environmental objectives.

The problem is formulated as a Multi Objective Mixed Integer Programming to decide the optimal configuration of a regional water system including environmental and economic considerations. The model is formulated to decide (i) the installation of new treatment plants, (ii) the actualization of the existing ones, and (iii) the connections within the new integration network. These changes on the water network allow to recycle and reuse water. The objective functions to minimize are the water usage from the source and the total cost of the water system. The problem is solved using the goal programming technique. The main novelties of this work are the large scale orientation of the formulation and the integration of economic and environmental objectives in the planning of a city scale water system.

The following sections present the formulation and solution of a Multi objective optimization model so as to redesign a city scale water network with environmental and economic objectives. The *Problem Structure* section introduces the water network and its representation as a superstructure with new possible treatment plants and connections. The *Mathematical Model* section presents the decision variables and equations to model the water network and decide the best configuration under environmental and economic objectives. The *Multi Objective Optimization Strategy* section presents the goal programming method to optimize simultaneous environmental and economic objective functions. This model is applied to Santiago, Chile, in the *Case Study* section. This section shows the main results of the optimization model. The *Discussions* section analyzes the results and the proposed formulation, to extract the main ideas in the *Conclusions* section.

### 3. Problem structure

The methodology used is shown in Fig. 1. First, an investigation of the current structure is carried out, and then possible changes in the network, its characteristics and requirements are studied. With this, the superstructure is modeled. The objective functions are

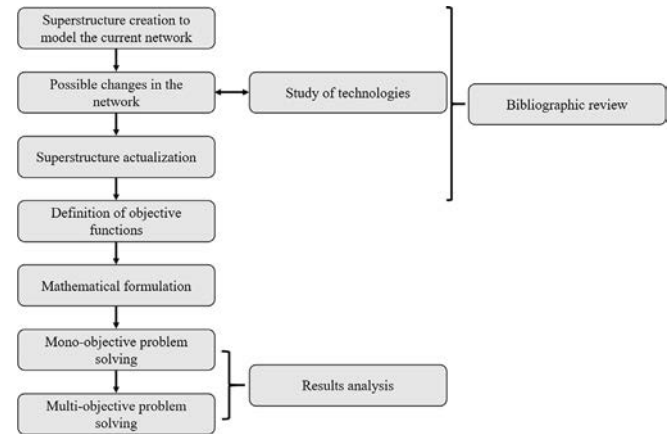


Fig. 1. Diagram representing the methodology followed in the research.

defined in order to formulate the problem mathematically, solving first the mono objective problems, and then solving the multi objective problem through the goal programming methodology.

In this problem, a city water system is modeled. This section describes the superstructure with all possible connections. The whole surface of the city is divided into sub regions, based on population distribution. Each sub region has its own population center to assign the location of the participants in the network. Participants are classified into (i) consumers; (ii) sources; (iii) distribution and collection nodes; (iv) treatment plants; and (v) final disposal sinks. These participants are connected through a network, which is represented by nodes and arcs, composing a graph. Fig. 2 shows the simplified graph.

There are two subsets of water sources and disposal sinks: surface and underground water. Consumption nodes represent a variety of uses: (i) domestic, (ii) commercial, (iii) industrial, (iv) agricultural, and (v) irrigation of urban areas. Each consumption node has its own demand and in the base case all the demands are satisfied with drinking water. Although some consumers require less restrictive qualities than drinking water. These demands could be covered by new treatment plants. It is also considered that consumption nodes location is in the population center.

In particular, industrial consumption is subdivided in two subsets, depending on consumption magnitude. The 20 companies with the highest water consumption were selected to form the first subset: large industrial consumers. The second subset group, other companies represented as a cluster within each sub region.

Concerning treatment nodes, there are Drinking Water Treatment Plants (DWTP), Wastewater Treatment Plants (WWTP), and Industrial Wastewater Treatment Plants (IWTP). Different sets are created for existing and new treatment plants and their different characteristics are explained below. Regarding existing plants, they are located in their original location. Also, all existing wastewater treatment plants have discharge quality water. Therefore, there is no recycling or reuse of water in the present system.

Four new sets of new wastewater treatment plants with different technological configurations were created. These can achieve four water qualities: (i) freshwater; (ii) drinking water; (iii) irrigation water; and (iv) discharge water. In addition, three new sets of modified treatment plants are created. Modified plants are existing plants modified to achieve a different output quality. These plants can achieve irrigation, water source, and drinking water quality. New treatment plants are positioned at each sub region boundary, because their installation would be more feasible in those places. Modified plants are positioned in the original location of the existing ones. With these new treatment plants it is possible

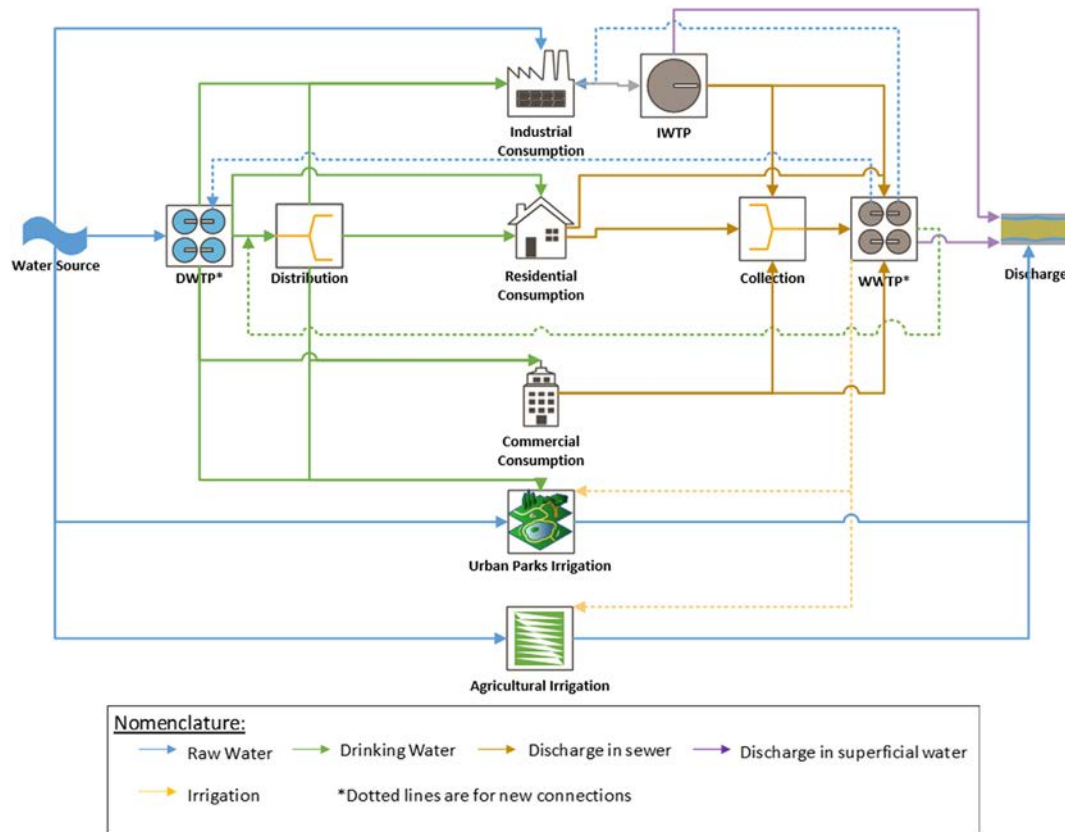


Fig. 2. Graph of the problem. Current and new plants are included as treatment nodes, and the respective consumption within a city.

to reduce water consumption from the natural source and create new possible connections and recycling within the system.

Both DWTP and WWTP are subdivided into two subsets depending on their treatment capacity: large and small plants. This division is useful for the calculation of economic and environmental indicators, and to differentiate distribution and collection networks. In particular, small plants supply/collect directly to their consumers, while large plants should make use of distribution/collection nodes to get to their consumers.

To achieve these recycling qualities, the use of certain water treatment technologies is necessary. The technologies used in each type of plant are presented in Table 1, which ensure the quality required for each consumer.

Distribution and collection nodes aim at representing water distribution and collection networks of the current system. In particular, this simplification allows to estimate efficiently water

losses in the pipelines. There is also a sink node to collect lost water from the nodes within the network.

The proposal model is a Mixed Integer Programming problem (MIP) which can be solved by some commercial solvers whose performance depends on initial values or possible limitation in the variables. The BARON solver was used because it is robust enough to solve this type of problem. Finally, the model was coded in the software GAMS.

#### 4. Mathematical model

The proposed model is based on the superstructure shown in Fig. 2. The model consists of a set of mass balances in the treatment plant nodes, distribution and collection nodes, and consumption nodes. It also includes, a set of constraints that allow the consumption demand of each node to be satisfied (fulfillment of the

**Table 1**  
Technologies used in different types of recycling plants, depending on the quality required. The references used are given by the technologies as follows: i) standard treatment: Rodríguez-Miranda (2015); ii) activated sludge: Guo et al. (2014); iii) micro-filtration: McGivney and Kawamura (2008); iv) nano-filtration: Adham et al. (1996); v) chlorination: McGivney and Kawamura (2008); vi) trickling filter: McGivney and Kawamura (2008); vi) ozonization: McGivney and Kawamura (2008); vii) reverse osmosis: Guo et al. (2014); viii) ion exchange: McGivney and Kawamura (2008); ix) filtration: McGivney and Kawamura (2008).

Quality required	Technology in big treatment plant	Technology in small treatment plant
Freshwater	Standard treatment, activated sludge, micro-filtration, nano-filtration and chlorination.	Standard treatment, trickling filter, micro-filtration, nano-filtration and ozonization.
Drinking water	Standard treatment, activated sludge, micro-filtration, reverse osmosis, chlorination and ion exchange.	Standard treatment, trickling filter, micro-filtration, reverse osmosis, ozonization and ion exchange.
Irrigation water	Standard treatment, activated sludge, filtration and chlorination.	Standard treatment, trickling filter, filtration and ozonization.
Discharge water	Standard treatment, activated sludge and chlorination.	Standard treatment, trickling filter and chlorination.

demand); a set of equations which define treatment capacity for new, existing and modified plants, and finally, it includes additional constraints to give a logical relationship of existence for treatment plants.

The sets, variables and subscripts used in the model are defined in *Nomenclature* section.

#### 4.1. Mass balances

It is considered that only total mass balances are required. This assumption implies that water quality at the exit of each treatment plant and network consumption satisfy the quality constraints for their respective user. Stationary state is also assumed for each node. Thus, the incoming flow rates will be the same as the outgoing flow rates. Finally, each flow density is assumed constant, then volumetric balances can be made.

##### 4.1.1. Global mass balances

For the global mass balance it is assumed that all flows from surface and underground water sources are equal to the flows discharged into the environment plus the losses of each node that go into the sink node as shown in Equation (1).

$$\sum_w \sum_i F_{w \rightarrow i} - \sum_j \sum_k F_{j \rightarrow k} + \sum_h \sum_s F_{h \rightarrow s}, \forall w \in W, \quad (1)$$

$$\forall k \in K, \forall s \in S, \forall i \in \{CFW\}, \forall h \in \{WT\}, \forall j \in \{DNC\}$$

In this equation,  $i$  corresponds to the water consuming nodes,  $j$  to those that discharge water into natural courses and  $h$  to all nodes which have water losses. On the other hand,  $W$  is the set of water sources,  $K$  corresponds the set of discharge points, and  $S$  to the set of sink points.

##### 4.1.2. Mass balances for each node

At any node, the incoming flow rates will be the same as the outgoing flow rates, as a result of the steady state assumption. This is not valid for water sources, discharge or sink because they have no input or output, respectively. A general expression is shown in Equation (2).

$$\sum_{i \in ON_j} F_{i \rightarrow j} - \sum_{h \in DN_j} F_{j \rightarrow h} + \sum_{s \in S} F_{j \rightarrow s} \forall j \in \{AS_j\} \quad (2)$$

In this equation,  $j$  corresponds to each node in which mass balance is carried out in all sets except water source, discharge, or sink, i.e.  $AS_j$ ;  $i$  represents the nodes of origin of the input flow rates, i.e.,  $ON_j$ ; and  $h$  represents the destination nodes of the output flow rates, i.e.,  $DN_j$ .

For the different nodes in the system, the source and destination nodes are particular. Certain characteristics for consumption, treatment, distribution, and collection nodes are specified below.

**4.1.2.1. Mass balance for consumption nodes.** Consumption nodes are: (i) Residential consumption; (ii) Commercial consumption; (iii) Industrial consumption; (iv) consumption for agricultural irrigation; and (v) consumption for urban areas irrigation.

Mass balance of residential and commercial consumption are similar. Both can be supplied from existing and new small DWTPs, new and modified smalls WWTPs with drinking water output quality, and from distribution nodes. On the other hand, residential and commercial consumption nodes can discharge into collection nodes and existing, new, or modified small WWTPs. As all consumption and treatment nodes, there is a flow to the sink. This is expressed in Equation (3).

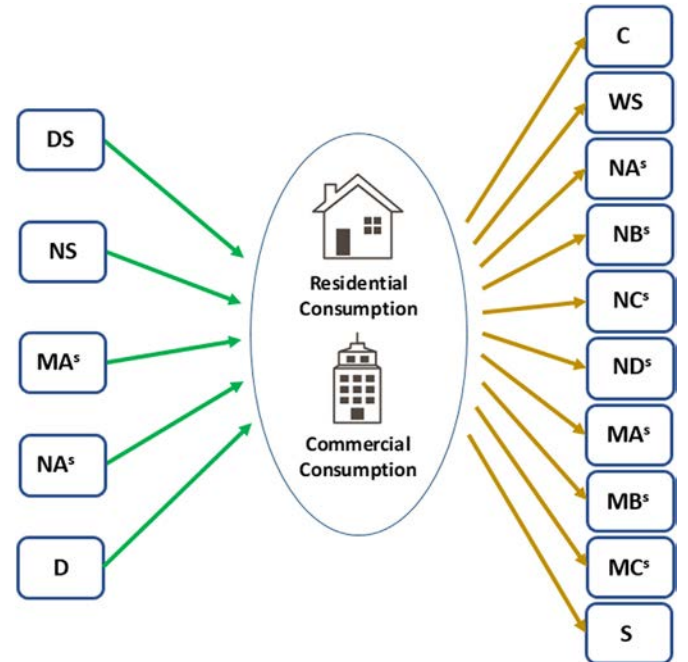
$$\begin{aligned} & \sum_{a_2 \in DS} F_{a_2 \rightarrow j} + \sum_{e_2 \in NS} F_{e_2 \rightarrow j} + \sum_{l_2 \in MA^s} F_{l_2 \rightarrow j} + \sum_{p_2 \in NA^s} F_{p_2 \rightarrow j} + \\ & \sum_{d \in D} F_{d \rightarrow j} - \sum_{c \in C} F_{j \rightarrow c} + \sum_{b_2 \in WS} F_{j \rightarrow b_2} + \sum_{p_2 \in NA^s} F_{j \rightarrow p_2} + \\ & \sum_{q_2 \in NB^s} F_{j \rightarrow q_2} + \sum_{r_2 \in NC^s} F_{j \rightarrow r_2} + \sum_{t_2 \in ND^s} F_{j \rightarrow t_2} + \sum_{l_2 \in MA^s} F_{j \rightarrow l_2} + \\ & \sum_{m_2 \in MB^s} F_{j \rightarrow m_2} + \sum_{n_2 \in MC^s} F_{j \rightarrow n_2} + \sum_{s \in S} F_{j \rightarrow s} \quad \forall j \in \{RC \cup CC\} \end{aligned} \quad (3)$$

In this equation,  $j$  corresponds to a residential or commercial consumption node. Fig. 3 represents the flows and sets involved in the mass balance of commercial and residential consumption.

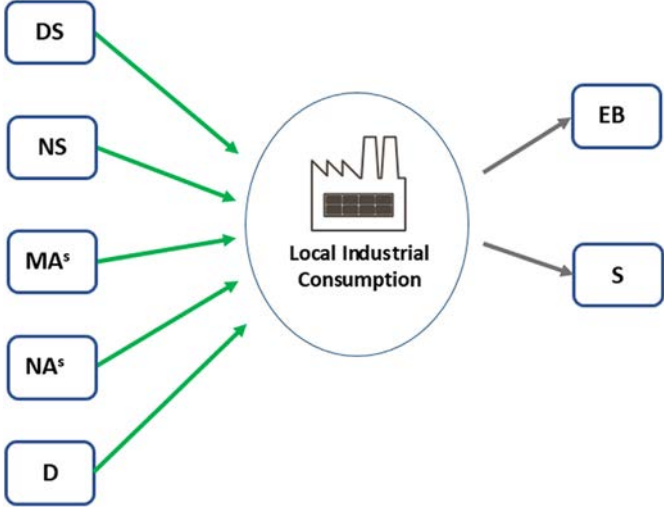
Industrial consumption is the most complex since it may require fresh or drinking water. In addition, all these nodes are considered to have effluent treatment plants. This allows them to discharge directly into natural watercourses or into the sewage system. Thus, industrial consumption nodes are subdivided in two main subsets: small industrial consumption and large industrial consumption.

Local consumption can be supplied only with drinking water from new and existing DWTPs, new small and large WWTPs with drinking output quality, and from distribution nodes. Outputs local industrial nodes are connected to their respective industrial effluent treatment plants and their losses go to the sink node. Therefore, mass balance is determined by Equation (4).

$$\begin{aligned} & \sum_{a_2 \in DS} F_{a_2 \rightarrow j} + \sum_{e_2 \in NS} F_{e_2 \rightarrow j} + \sum_{l_2 \in MA^s} F_{l_2 \rightarrow j} + \sum_{p_2 \in NA^s} F_{p_2 \rightarrow j} + \\ & \sum_{d \in D} F_{d \rightarrow j} - \sum_{g_s \in EB} F_{j \rightarrow g_s} + \sum_{s \in S} F_{j \rightarrow s}, \quad \forall j \in IB \end{aligned} \quad (4)$$



**Fig. 3.** Representation of the mass balance of commercial and residential consumption.  $DS$ : existing small DWTPs with surface water consumption;  $NS$ : new small DWTPs;  $MA^s$ : modified small WWTPs with drinking water output quality;  $NA^s$ : new small WWTPs with drinking water output quality;  $D$ : distribution;  $C$ : collection;  $WS$ : small existing WWTPs;  $NA^s$ : new small WWTPs with drinking water output quality;  $NB^s$ : new small WWTPs with fresh water output quality;  $NC^s$ : new small WWTPs with irrigation water output quality;  $ND^s$ : new small WWTPs with discharge water output quality;  $MA^s$ : modified small WWTPs with drinking water output quality;  $MB^s$ : modified small WWTPs with fresh water output quality;  $MC^s$ : modified small WWTPs with irrigation water output quality;  $S$ : sink.



**Fig. 4.** Representation of the mass balance of local industrial consumption. *DS*: existing small DWTPs with surface water consumption; *NS*: new small DWTPs; *MA<sup>s</sup>*: modified small WWTPs with drinking water output quality; *NA<sup>s</sup>*: new small WWTPs with drinking water output quality; *D*: distribution; *EB*: industrial effluent treatment plant connected with by-district industrial consumers; *S*: sink.

**Fig. 4** represents the flows and sets involved in the mass balance of local industrial consumption.

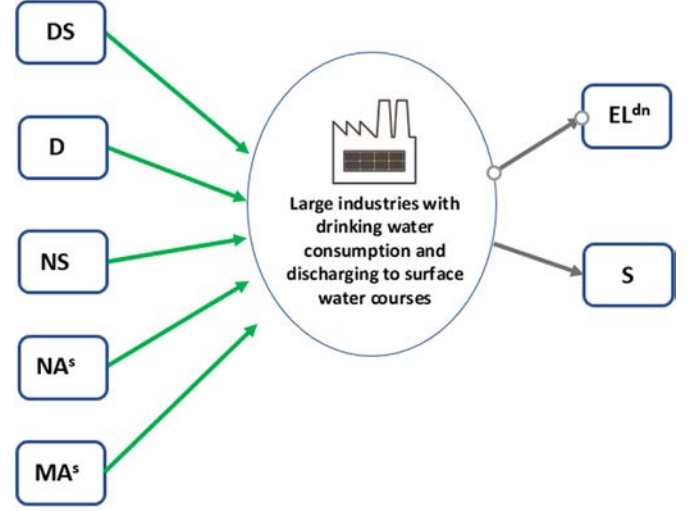
On the other side, large industrial consumers are subdivided into four subsets, depending on the input and output water quality: (i) consumers supplied with fresh water and discharging into natural watercourses, (ii) consumers supplied with fresh water and discharging into the sewer system, (iii) consumers supplied with drinking water and discharging to natural watercourses and (iv) consumers supplied with drinking water and discharging to the sewer system. As an example, mass balances for large industrial consumers supplied with drinking water and discharging into surface water courses is presented in Equation (5) and its representation is shown in **Fig. 5**. On the other hand, the mass balance for large industrial consumers supplied by fresh water and discharging to sewage system is presented in Equation (6) and its representation can be seen in **Fig. 6**.

$$\sum_{d \in D} F_{d \rightarrow j} + \sum_{a_2 \in DS} F_{a_2 \rightarrow j} + \sum_{e_2 \in NS} F_{e_2 \rightarrow j} + \sum_{p_2 \in NA^s} F_{p_2 \rightarrow j} + \sum_{l_2 \in MA^s} F_{l_2 \rightarrow j} + \sum_{g_2 \in EL^{dn}} F_{g_2 \rightarrow j} + \sum_{s \in S} F_{j \rightarrow s}, \forall j \in IL^{dn} \quad (5)$$

Mass balance of the agricultural irrigation consumption nodes is given by Equation (7) and its representation is shown in **Fig. 7**. Agricultural consumption can be supplied by natural water sources or plants with irrigation water quality. These WWTPs may be large or small, new or modified. The respective discharge of water can be done into natural groundwater courses and into the sink.

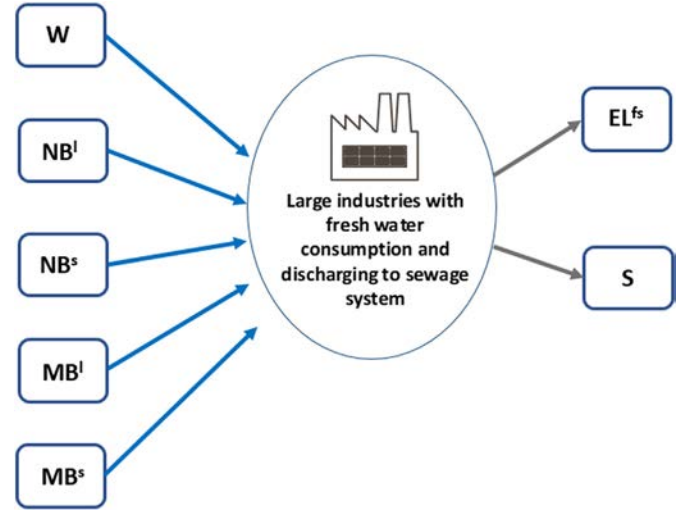
$$\sum_{w \in W} F_{w \rightarrow j} + \sum_{r_1 \in NC^l} F_{r_1 \rightarrow j} + \sum_{r_2 \in NC^s} F_{r_2 \rightarrow j} + \sum_{n_1 \in MC^l} F_{n_1 \rightarrow j} + \sum_{n_2 \in MC^s} F_{n_2 \rightarrow j} + \sum_{k_0 \in K^G} F_{j \rightarrow k_0} + \sum_{s \in S} F_{j \rightarrow s}, j \in AC \quad (7)$$

Urban areas irrigation (e.g. urban parks, green avenues, neighborhoods, green spaces) is subdivided in two subsets, depending on its source. The first one is supplied by drinking or fresh water; and the second, by fresh water. Both groups discharge into natural groundwater courses or into the sink. Mass balance of the first subset is given by Equation (8) and its representation is given in



**Fig. 5.** Representation of the mass balance of large industrial consumption supplied with drinking water and discharging into surface water courses. *DS*: small existing DWTPs; *D*: distribution; *NS*: new small DWTPs; *NA<sup>s</sup>*: new small WWTPs with drinking water output quality; *MA<sup>s</sup>*: modified small WWTPs with drinking water output quality; *EL<sup>dn</sup>*: related to *IL<sup>dn</sup>*; *S*: sink.

$$\sum_{w \in W} F_{w \rightarrow j} + \sum_{q_1 \in NB^l} F_{q_1 \rightarrow j} + \sum_{q_2 \in NB^s} F_{q_2 \rightarrow j} + \sum_{m_1 \in MB^l} F_{m_1 \rightarrow j} + \sum_{m_2 \in MB^s} F_{m_2 \rightarrow j} + \sum_{g_3 \in EL^s} F_{j \rightarrow g_3} + \sum_{s \in S} F_{j \rightarrow s}, \forall j \in IL^s \quad (6)$$



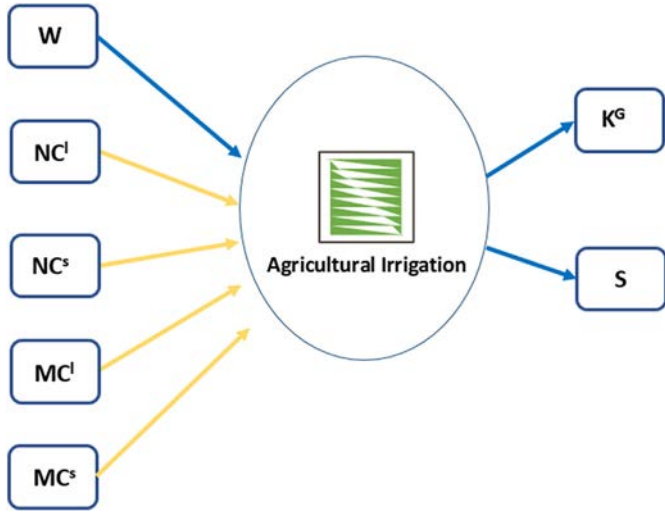
**Fig. 6.** Representation of the mass balance of large industrial consumption supplied with fresh water and discharging into sewage system. *W*: water source; *NB<sup>l</sup>*: new big WWTPs with fresh water output quality; *NB<sup>s</sup>*: new small WWTPs with fresh water output quality; *MB<sup>l</sup>*: modified big WWTPs with fresh water output quality; *MB<sup>s</sup>*: modified small WWTPs with fresh water output quality; *EL<sup>fs</sup>*: related to *IL<sup>fs</sup>*.

**Fig. 8**

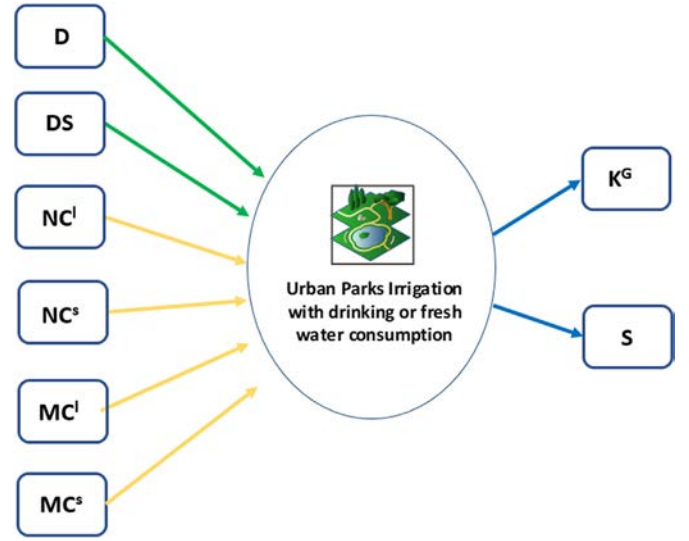
$$\sum_{w \in W} F_{w \rightarrow j} + \sum_{r_1 \in NC^l} F_{r_1 \rightarrow j} + \sum_{r_2 \in NC^s} F_{r_2 \rightarrow j} + \sum_{n_1 \in MC^l} F_{n_1 \rightarrow j} + \sum_{n_2 \in MC^s} F_{n_2 \rightarrow j} + \sum_{k_0 \in K^G} F_{j \rightarrow k_0} + \sum_{s \in S} F_{j \rightarrow s}, \forall j \in PF \quad (8)$$

Mass balance of the second subset is given by Equation (9) and

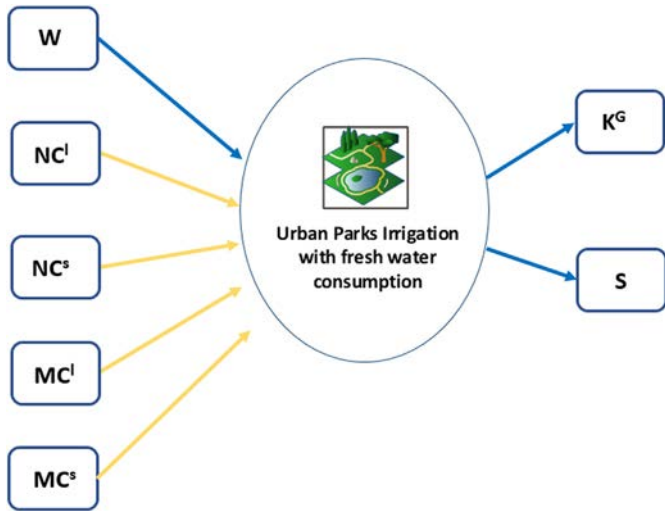




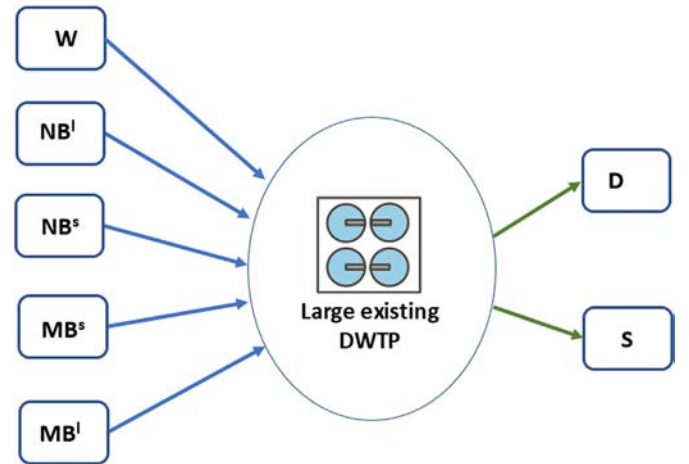
**Fig. 7.** Representation of the mass balance of agricultural irrigation consumption.  $W$ : water source;  $NC^l$ : new large WWTPs with irrigation water output quality;  $NC^s$ : new small WWTPs with irrigation water output quality;  $MC^l$ : modified large WWTPs with irrigation water output quality;  $MC^s$ : modified small WWTPs with irrigation water output quality;  $K^G$ : natural groundwater discharge course;  $S$ : sink.



**Fig. 9.** Representation of the mass balance of urban park irrigation with drinking or fresh water consumption.  $D$ : distribution;  $DS$ : small existing DWTP;  $NC^l$ : new large WWTPs with irrigation water output quality;  $NC^s$ : new small WWTPs with irrigation water output quality;  $MC^l$ : modified large WWTPs with irrigation water output quality;  $MC^s$ : modified small WWTPs with irrigation water output quality;  $K^G$ : natural groundwater discharge course;  $S$ : sink.



**Fig. 8.** Representation of the mass balance of urban park irrigation with fresh water consumption.  $W$ : water source;  $NC^l$ : new large WWTPs with irrigation water output quality;  $NC^s$ : new small WWTPs with irrigation water output quality;  $MC^l$ : modified large WWTPs with irrigation water output quality;  $MC^s$ : modified small WWTPs with irrigation water output quality;  $K^G$ : natural groundwater discharge course;  $S$ : sink.



**Fig. 10.** Representation of the mass balance of a large existing drinking water treatment plant.  $W$ : water source;  $NB^l$ : new big WWTPs with fresh water output quality;  $NB^s$ : new small WWTPs with fresh water output quality;  $MB^l$ : modified big WWTPs with fresh water output quality;  $MB^s$ : modified small WWTPs with fresh water output quality;  $D$ : distribution;  $S$ : sink.

its representation is shown in Fig. 9.

$$\sum_{a_2 \in DS} F_{a_2 \rightarrow j} + \sum_{d \in D} F_{d \rightarrow j} + \sum_{r_1 \in NC^l} F_{r_1 \rightarrow j} + \sum_{r_2 \in NC^s} F_{r_2 \rightarrow j} + \sum_{n_1 \in MC^l} F_{n_1 \rightarrow j} + \sum_{n_2 \in MC^s} F_{n_2 \rightarrow j} + \sum_{k_0 \in K^G} F_{j \rightarrow k_0} + \sum_{s \in S} F_{j \rightarrow s}, \forall j \in PD \quad (9)$$

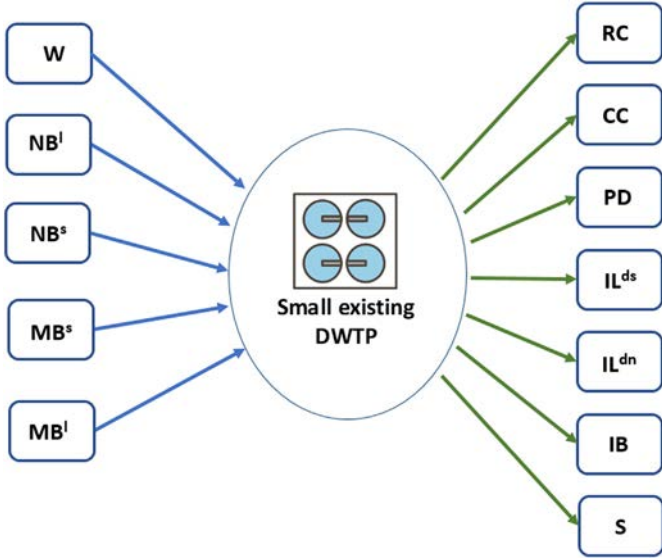
**4.1.2.2. Mass balances of treatment nodes.** Treatment nodes are subdivided into existing, modified and new plants. These can be drinking water treatment plants or wastewater treatment plants. In addition, these sets have subsets of large and small installations.

Large installations are connected to distribution and collection nodes, while small installations are not.

Concerning existing plants, mass balance of large existing DWTPs is determined by Equation (10) and its representation is given by Fig. 10. Where input flows come from natural water sources and from new and modified wastewater treatment plants that have fresh water output quality. Output flows go to the distribution nodes and to the sink.

$$\sum_{w \in W} F_{w \rightarrow j} + \sum_{q_1 \in NB^l} F_{q_1 \rightarrow j} + \sum_{q_2 \in NB^s} F_{q_2 \rightarrow j} + \sum_{m_1 \in MB^l} F_{m_1 \rightarrow j} + \sum_{m_2 \in MB^s} F_{m_2 \rightarrow j} + \sum_{d \in D} F_{j \rightarrow d} + \sum_{s \in S} F_{j \rightarrow s}, \forall j \in DL \quad (10)$$

Mass balance of small and large plants is similar, but their output flows are not connected to the distribution nodes, they are connected directly to the different consumers. Then mass balance



**Fig. 11.** Representation of the mass balance for small existing drinking water treatment plant. *W*: water source; *NB<sup>I</sup>*: new big WWTPs with fresh water output quality; *NB<sup>S</sup>*: new small WWTPs with fresh water output quality; *MB<sup>I</sup>*: modified big WWTPs with fresh water output quality; *MB<sup>S</sup>*: modified small WWTPs with fresh water output quality; *RC*: residential consumption; *CC*: commercial consumption; *PD*: urban park irrigation with drinking water consumption; *IL<sup>ds</sup>*: large industrial consumers with drinking water consumption and sewage discharge; *IL<sup>dn</sup>*: large industrial consumers with drinking water consumption and natural water course discharge; *IB*: by-district industrial consumers; *S*: sink.

for small existing DWTPs is given by Equation (11) and its representation is shown in Fig. 11.

$$\begin{aligned} & \sum_{w \in W} F_{w \rightarrow j} + \sum_{q_1 \in NB^I} F_{q_1 \rightarrow j} + \sum_{q_2 \in NB^S} F_{q_2 \rightarrow j} + \sum_{m_1 \in MB^I} F_{m_1 \rightarrow j} + \\ & \sum_{m_2 \in MB^S} F_{m_2 \rightarrow j} + \sum_{i_1 \in RC} F_{j \rightarrow i_1} + \sum_{i_2 \in CC} F_{j \rightarrow i_2} + \sum_{u_1 \in PD} F_{j \rightarrow u_1} + \\ & \sum_{f_1 \in IL^{ds}} F_{j \rightarrow f_1} + \sum_{f_2 \in IL^{dn}} F_{j \rightarrow f_2} + \sum_{f_5 \in IB} F_{j \rightarrow f_5} + \sum_{s \in S} F_{j \rightarrow s}, \forall j \in DS \end{aligned} \quad (11)$$

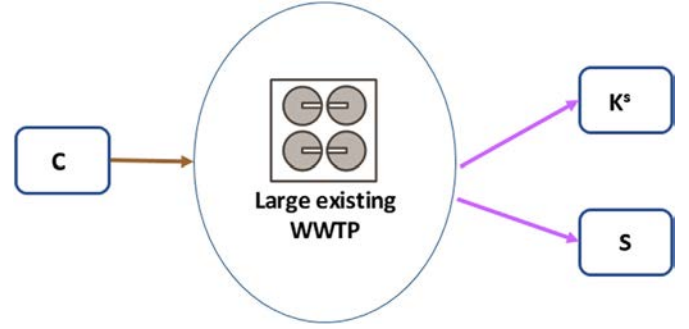
Existing wastewater treatment plants only achieve output quality of discharge in natural watercourses. Inflows of large existing WWTPs come from collection nodes and the outflows go into natural discharge courses and to the sink. Mass balance of a large existing WWTP is given by Equation (12) and its representation is shown in Fig. 12.

$$\sum_{c \in C} F_{c \rightarrow j} + \sum_{k_1 \in K^S} F_{j \rightarrow k_1} + \sum_{s \in S} F_{j \rightarrow s}, \forall j \in WL \quad (12)$$

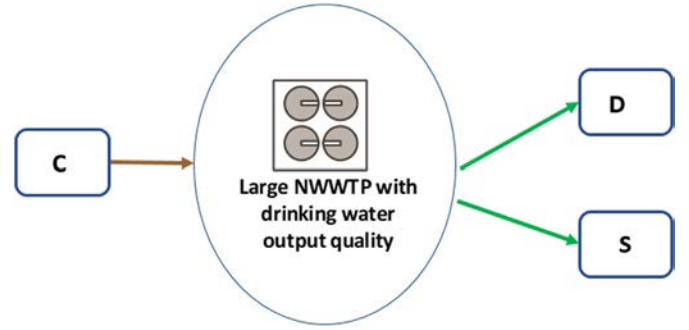
Mass balance of small treatment plants is similar, but the incoming flows come directly from consumers, in particular from commercial, residential, and industrial consumers that discharge into the sewer system.

Concerning new plants, new DWTPs allow to install a new plant in a different location. Mass balances for new large and small DWTPs are the same as existing ones, because the only thing that change is the node location.

New WWTPs can achieve four new output qualities: (i) drinking water, (ii) fresh water, (iii) irrigation water, and (iv) discharge in natural course. Their respective mass balances are determined by Equations (13)–(16), respectively. And their respective representations are given by Figs. 13–16 for each case.



**Fig. 12.** Representation of the mass balance of a large existing wastewater treatment plant. *C*: collection; *K<sup>S</sup>*: natural surface discharge course; *S*: sink.



**Fig. 13.** Representation of the mass balance of a large new wastewater treatment plant with drinking water output quality. *C*: collection; *D*: distribution; *S*: sink.

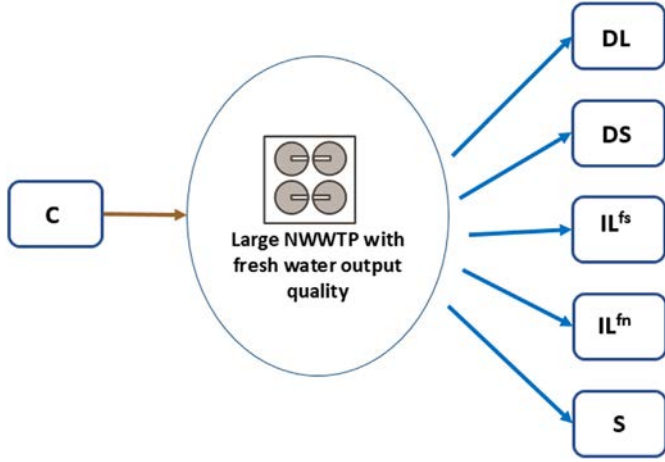
$$\begin{aligned} & \sum_{c \in C} F_{c \rightarrow j} + \sum_{a_1 \in DL} F_{j \rightarrow a_1} + \sum_{a_2 \in DS} F_{j \rightarrow a_2} + \sum_{f_3 \in IL^S} F_{j \rightarrow f_3} + \\ & \sum_{f_4 \in IL^{dn}} F_{j \rightarrow f_4} + \sum_{s \in S} F_{j \rightarrow s}, \forall j \in NB^I \end{aligned} \quad (14)$$

$$\sum_{c \in C} F_{c \rightarrow j} + \sum_{d \in D} F_{j \rightarrow d} + \sum_{s \in S} F_{j \rightarrow s}, \forall j \in NA^I \quad (13)$$

In what refers to modified plants, only wastewater treatment plants can be improved to achieve a different output quality: (i) drinking water, (ii) fresh water, and (iii) irrigation water. Their mass balances are the same as those of new WWTPs.

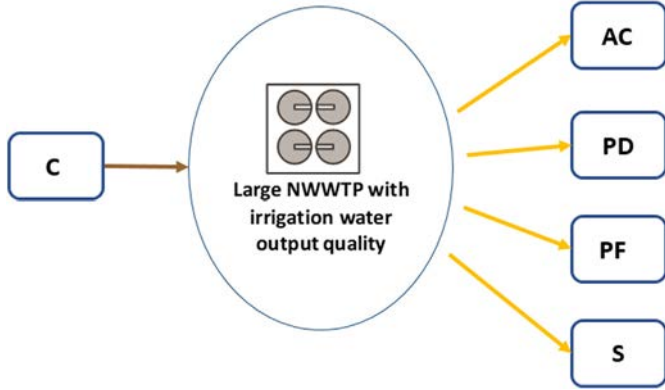
Finally, for industrial wastewater treatment plants, the same logic as for their respective sources of consumption, i.e., if it is a large plant which discharge into sewage system, then the plant will also discharge into the sewage system.

**4.1.2.3. Mass balances for distribution and collection nodes.** Distribution and collection nodes aim at representing the network of the water system. Large water plants use distribution and collection nodes, in order to take into account water losses associated with the distribution network. The mass balance of the distribution nodes is given by Equation (17) and its representation is shown in Fig. 17. Flows into the distribution nodes come from large existing and new drinking water treatment plants and large new and modified wastewater treatment plants with drinking quality. Output flows supply water consumption in the network.



**Fig. 14.** Representation of the mass balance of a large new waste water treatment plant with fresh water output quality. C: collection; DL: large existing DWTPs; DS: small existing DWTPs;  $IL^{fs}$ : large industrial consumers with fresh water consumption and sewage discharge;  $IL^{fn}$ : large industrial consumers with fresh water consumption and natural water course discharge; S: sink.

$$\sum_{c \in C} F_{c \rightarrow j} + \sum_{h_1 \in AC} F_{j \rightarrow h_1} + \sum_{u_1 \in PD} F_{j \rightarrow u_1} + \sum_{u_2 \in PF} F_{j \rightarrow u_2} + \sum_{s \in S} F_{j \rightarrow s}, \forall j \in NC^l \quad (15)$$

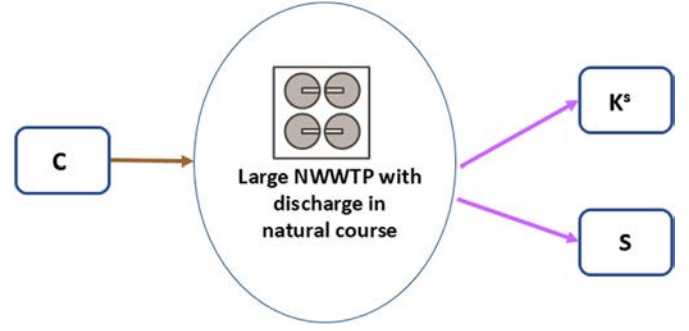


**Fig. 15.** Representation of the mass balance of a large new waste water treatment plant with irrigation water output quality. C: collection; AC: agricultural irrigation; PD: urban park irrigation with drinking water consumption; PF: urban park irrigation with fresh water consumption; S: sink.

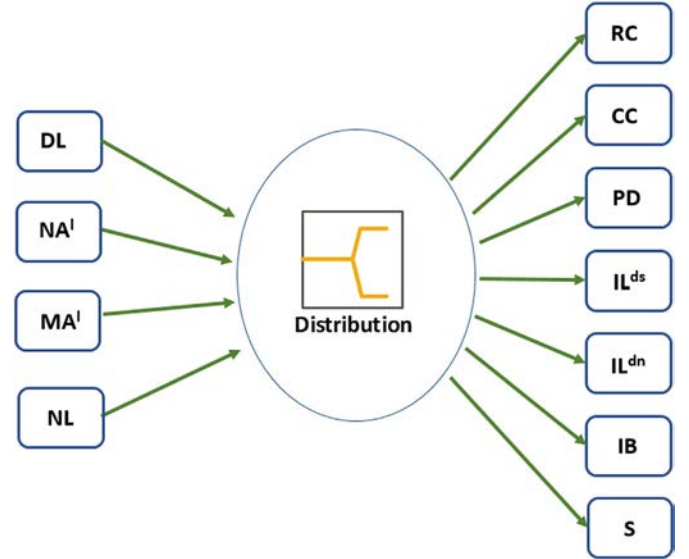
$$\sum_{c \in C} F_{c \rightarrow j} + \sum_{k1 \in K^s} F_{j \rightarrow k1} + \sum_{s \in S} F_{j \rightarrow s}, \forall j \in ND^l \quad (16)$$

$$\sum_{a_1 \in DL} F_{a_1 \rightarrow j} + \sum_{e_1 \in NL} F_{e_1 \rightarrow j} + \sum_{p_1 \in NA^l} F_{p_1 \rightarrow j} + \sum_{l_1 \in MA^l} F_{l_1 \rightarrow j} + \sum_{i_1 \in RC} F_{j \rightarrow i_1} + \sum_{i_2 \in CC} F_{j \rightarrow i_2} + \sum_{u_1 \in PD} F_{j \rightarrow u_1} + \sum_{f_1 \in IL^{ds}} F_{j \rightarrow f_1} + \sum_{f_2 \in IL^{dn}} F_{j \rightarrow f_2} + \sum_{f_5 \in IB} F_{j \rightarrow f_5} + \sum_{s \in S} F_{j \rightarrow s}, \forall j \in D \quad (17)$$

On the other hand, mass balance of collection nodes is determined by Equation (18) and its representation is given by Fig. 18.



**Fig. 16.** Representation of the mass balance of a large new waste water treatment plant with discharge in natural course. C: collection;  $K^s$ : natural surface discharge course; S: sink.



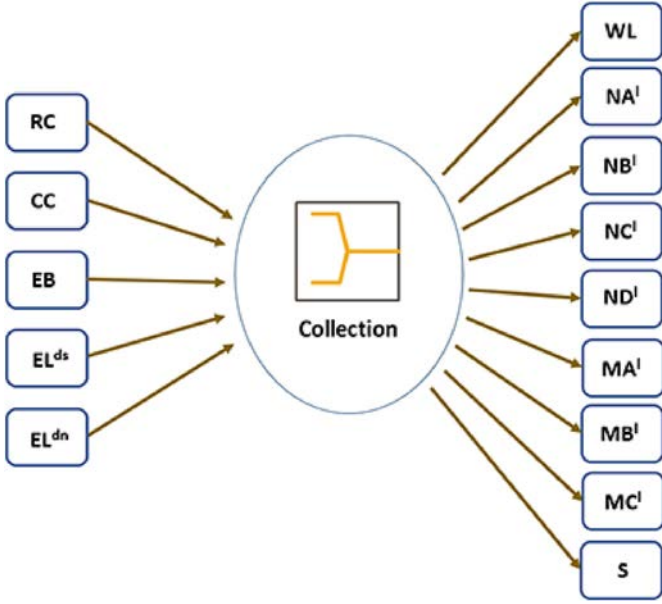
**Fig. 17.** Representation of the mass balance of a distribution node. DL: large existing DWTPs;  $NA^l$ : new large WWTPs with drinking water output quality;  $MA^l$ : modified large WWTPs with drinking water output quality; NL: new large DWTPs; RC: residential consumption; CC: commercial consumption; PD: urban park irrigation with drinking water consumption;  $IL^{ds}$ : large industrial consumers with drinking water consumption and sewage discharge;  $IL^{dn}$ : large industrial consumers with drinking water consumption and natural water course discharge; IB: by-district industrial consumers; S: sink.

The flows into collection nodes come from different consumers. And the output of collection nodes are connected to large existing, new and modified wastewater treatment plants.

$$\sum_{i_1 \in RC} F_{i_1 \rightarrow j} + \sum_{i_2 \in CC} F_{i_2 \rightarrow j} + \sum_{g_1 \in EL^{ds}} F_{g_1 \rightarrow j} + \sum_{g_3 \in EL^{fs}} F_{g_3 \rightarrow j} + \sum_{g_5 \in EB} F_{g_5 \rightarrow j} + \sum_{b_1 \in WL} F_{j \rightarrow b_1} + \sum_{p_1 \in NA^l} F_{j \rightarrow p_1} + \sum_{q_1 \in NB^l} F_{j \rightarrow q_1} + \sum_{r_1 \in NC^l} F_{j \rightarrow r_1} + \sum_{t_1 \in ND^l} F_{j \rightarrow t_1} + \sum_{l_1 \in MA^l} F_{j \rightarrow l_1} + \sum_{m_1 \in MB^l} F_{j \rightarrow m_1} + \sum_{n_1 \in MC^l} F_{j \rightarrow n_1} + \sum_{s \in S} F_{j \rightarrow s}, \forall j \in C \quad (18)$$

#### 4.2. Covering the demand

As mentioned above, each consumption node has an associated water demand. Depending its consumption type and location, the demand is different. To satisfy the demand of each node, Equation (19) must be respected.



**Fig. 18.** Representation of the mass balance of collection node. *RC*: residential consumption; *CC*: commercial consumption; *EB*: industrial effluent treatment plant connected with large industrial consumers; *EL<sup>ds</sup>*: related to *IL<sup>ds</sup>*; *EL<sup>dn</sup>*: related to *IL<sup>dn</sup>*; *WL*: large existing DWTPs; *NA<sup>l</sup>*: new large WWTPs with drinking water output quality; *NB<sup>l</sup>*: new large WWTPs with fresh water output quality; *NC<sup>l</sup>*: new large WWTPs with irrigation water output quality; *ND<sup>l</sup>*: new large WWTPs with discharge water output quality; *MA<sup>l</sup>*: modified large WWTPs with drinking water output quality; *MB<sup>l</sup>*: modified large WWTPs with fresh water output quality; *MC<sup>l</sup>*: modified large WWTPs with irrigation water output quality; *S*: sink.

$$\sum_{i \in ON_j} F_{i \rightarrow j} \geq DM_{\{j,p\}}, \forall j \in AD_j, \forall p \in CT \quad (19)$$

In this equation,  $i$  corresponds to nodes of origin of  $j$ , i.e.  $ON_j$ ,  $j$  being the current node, i.e. where the demand must be satisfied ( $AD_j$ ), which can be a residential, commercial, industrial, agricultural, and urban park irrigation consumption demand; and  $p$  represent each district.

### 4.3. Treatment plant capacity

It is necessary to restrict treatment capacity of new, existing and modified plants.

In all capacity restrictions there is a territorial association of plants and consumers sharing the plant district, i.e. the capacity of a plant in the  $p'$  district, shall meet the demands of  $p'$  district users.

#### 4.3.1. New drinking water treatment plant capacity

As mentioned above, there are large and small treatment plants. The value separating both categories varies with the consumption of each district. The binary variable  $E_i$  corresponds to the existence of the treatment plant  $i$ . The problem becomes mixed integer, with continuous and discrete variables. In the case of big new drinking water treatment plants Equation (20) must be respected.

$$\sum_{d \in D} F_{i \rightarrow d} \geq \sum_j DM_{\{j,p'\}} \cdot E_i, \forall i \in NL, \forall p' \in CT \left| p' \text{ is the district where } i \text{ is positioned} \right. \quad (20)$$

In this equation,  $i$  corresponds to each new big drinking water treatment plant per district  $p'$ ,  $d$  belongs to the distribution set,  $j$  corresponds to each consumption in district  $p'$ , and  $p'$  corresponds to each district, in particular, the district in which the plant  $i$  is located.

On the other hand, for small new drinking water treatment plants, Equation (21) must be respected. A new parameter ' $m$ ', which corresponds to a small value in comparison to the demands of the district, is used to flexibilize the creation of small plants. This is necessary to give realism to the system concerning the requirements of its participants. It can happen that drinking water plants supply the nearby population and also the population that is not in its own district. In fact, the plants do not have a fixed capacity only for the consumption of its district inhabitants, its capacity varies depending on the requirements of the participants of the systems. This flexibility is given by the parameter ' $m$ '.

$$\sum_j F_{i \rightarrow j} \leq \left( \sum_j DM_{\{j,p'\}} + m \right) \cdot E_i, \forall i \in NS, \forall p' \in CT \left| \right. \quad (21)$$

$p'$  is the district where  $i$  is positioned

In this equation,  $i$  corresponds to each new small drinking water treatment plant in each district,  $j$  corresponds to all consumers requiring drinking water in the district  $p'$ , and  $p'$  corresponds to each district, in particular, where the plant  $i$  is located.

#### 4.3.2. New wastewater treatment plant capacity

For new big wastewater treatment plants, Equation (22) must be respected.

$$\sum_c F_{c \rightarrow i} \geq \sum_j DM_{\{j,p'\}} \cdot E_i, \forall i \in \{NA^l \cup NB^l \cup NC^l \cup ND^l\}, \forall p' \in CT \left| \right. \quad (22)$$

$p'$  is the district where  $i$  is positioned

In this equation,  $i$  corresponds to each new big wastewater treatment plant in each district  $p'$ ,  $c$  belongs to the collection set,  $j$  corresponds to each sewer user in the district  $p'$ , and  $p'$  corresponds to each district, in particular the district where plant  $i$  is located. On the other hand, for small new wastewater treatment plant, Equation (23) must be respected.

$$\sum_j F_{j \rightarrow i} \leq \left( \sum_j DM_{\{j,p'\}} + m \right) \cdot E_i, \forall i \in \{NA^s \cup NB^s \cup NC^s \cup ND^s\}, \forall p' \in CT \left| p' \text{ is the district where } i \text{ is positioned} \right. \quad (23)$$

In this equation,  $m$  corresponds to the parameter mentioned above,  $i$  corresponds to each new small wastewater treatment plant in each district  $p'$ ,  $j$  corresponds to each sewer user in the district  $p'$ , and  $p'$  corresponds to each district, in particular where the plant  $i$  is located.

#### 4.3.3. Existing or modified treatment plant capacity

Flow rates through existing or modified wastewater treatment plants must vary according to season. However, this variation does not imply an extension of existing plants. This fluctuation can be observed in Fig. 19. This figure shows a higher consumption of drinking water in summer than in winter.

Thus, existing or modified plants will only exist if the flow rate treated is higher than the winter variation and lower than the summer variation. This means it can treat 25% less than the winter fluctuation, which in turn is 15% less than the current flow, i.e.,  $0.75 \cdot 0.85$  of the current flow. On the other hand, the plant can treat 23% more than the current flow, which is the summer variation. In order to increase its capacity, an investment must be made on the treatment plant, so it was not considered a flexibility in the case of the upper limit. These percentages were obtained from the drinking water treatment plant in operation in Santiago. This logic is reflected in Equations (24) and (25).

$$\sum_{i \in ON_j} F_{i \rightarrow j} \geq 0.75 \cdot 0.85 \cdot AF_j \cdot E_j, \forall j \in EW \quad (24)$$

$$\sum_{i \in ON_j} F_{i \rightarrow j} \leq 1.23 \cdot AF_j \cdot E_j, \forall j \in EW \quad (25)$$

In this equation,  $i$  are the origin nodes of  $j$ , i.e.  $ON_j, j$  corresponds to each wastewater treatment plant,  $AF_j$  is the current flow rate treated by the plant, and  $E_j$  corresponds to the existence of the plant  $j$ . In the case of drinking water treatment plants, the analysis is similar, but the outflows are taken to validate the plant existence, as shown in Equations (26) and (27).

$$\sum_{i \in DN_j} F_{j \rightarrow i} \geq 0.75 \cdot 0.85 \cdot AF_j \cdot E_j, \forall j \in ED \quad (26)$$

$$\sum_{i \in DN_j} F_{j \rightarrow i} \leq 1.23 \cdot AF_j \cdot E_j, \forall j \in ED \quad (27)$$

In this equation,  $i$  are the consumers of drinking water, i.e.  $DN_j, j$  corresponds to each drinking water treatment plant,  $AF_j$  is the current flow rate treated by the plant  $j$ , and  $E_j$  corresponds to plant  $j$  existence.

#### 4.4. Logical relationships of existence

If the plant does not exist, then the incoming flows must be zero. This can be written mathematically through Equation (28) applying

the *BigM* method (Song, 2015).

In consequence there is a parameter corresponding to a big number ( $M$ ). This value has to be greater than all the flow rates being treated.

$$\sum_i F_{i \rightarrow j} \leq M \cdot E_j \quad (28)$$

In this equation,  $i$  belongs to the set of origin nodes of the treatment plant  $j$ , i.e.  $ON_j, j$  corresponds to each wastewater treatment plant,  $M$  is a parameter, and  $E_j$  corresponds to the plant  $j$  existence.

In addition, there are also coexistence relations of plants: an existing and a modified plant cannot exist in the same place, as shown in Equation (29).

$$\sum_{j \in \{EW \cup MW\}} E_j \leq 1 \quad (29)$$

In this equation,  $j$  corresponds to an existing or a modified plant.

#### 4.5. Cost

The costs in the problem are divided in operational costs (*OpC*) and capital costs (*CapC*). The *OpC* are estimated by water transport costs, while *CapC* are estimated by the cost of installing new plants or of modifying the existing ones. Operating costs are given by equation (30).

$$OpC = T \cdot E \cdot \sum_j \sum_i F_{i \rightarrow j} \cdot g \cdot (h_j - h_i) + f \cdot \frac{dist_{(i,j)} \cdot v^2}{2D} \quad (30)$$

Where '*OpC*' is the operational cost of the system, ' $T$ ' is the annual operational time, ' $E$ ' is the cost per unit of electricity, ' $f$ ' is the Darcy factor, ' $h_i$ ' is the height of the node  $i$ , ' $dist_{(i,j)}$ ' is the distance from node  $i$  to node  $j$ , ' $v$ ' is the linear velocity, ' $g$ ' is the gravity acceleration, ' $D$ ' is the diameter of each pipe (considering 4 types of pipe sizes) and ' $F_{i \rightarrow j}$ ' is the flow rate from node  $i$  to node  $j$  equation (30) turns the problem non linear. To solve this and reduce computational times, linear flow velocity and pipe diameters are defined as parameters, generating a Mixed integer programming problem. The parameters used for the problem can be found in Appendix 1.

The capital cost for the treatment units considers the fixed cost and the variable cost generated by their flow rates. Equation (31) is the general equation to represent the capital cost for the installation or modification of treatment plants (Rubio Castro et al., 2012).

$$CapC = K_f \cdot E_i \cdot \left( \sum_i Cvr_i \cdot \sum_j F_{j \rightarrow i} + Cfr_i + Ter_i \right) \quad (31)$$

Where ' $K_f$ ' is the factor to annualize cost, ' $E_i$ ' is the variable to represent the existence of the treatment plant  $i$ ,  $Cvr_i$  correspond to the investment cost parameter of plant  $i$  which is multiplied by the summation of the flows entering plant  $i$ ,  $Cfr_i$  correspond to the intercept point in the ordinate, depending on the plant  $i$ , and  $Ter_i$  correspond to the terrain cost of the plant  $i$ . These parameters can be seen in Annex 8.

#### 4.6. Objective functions

The problem has two opposing objective functions to be minimized: water flow used from the water source and the total cost. Thus, these two objective functions FO1 and FO2 can be represented by Equations (32) and (33), respectively.

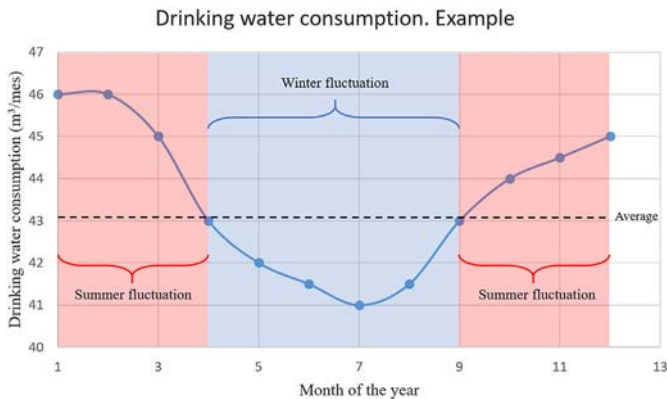


Fig. 19. Drinking water consumption during a year. Illustrative example for the comprehension of the text. These values may vary each year.

$$FO1 \quad \min \sum_{j \in CFW} F_{w \rightarrow j} \quad \min G0, \forall w \in W \quad (32)$$

$$FO2 \quad \min TC \quad \min (OpC + CapC) \quad (33)$$

Where  $G0$  is the total fresh water consumed,  $OpC$  is the operational cost, and  $CapC$  is the investment cost.

## 5. Multi-objective optimization strategy

A goal programming method is applied to solve the MOO problem, where the relative importance of each function is assumed to be equal. The multi objective formulation is shown in equation (34) subject to the constraints 35 and 36:

$$\min \gamma \quad (34)$$

$$\frac{G0}{G0_{mid}} - \frac{G0_{id}}{G0_{id}} \cdot w_1 \leq \gamma \quad (35)$$

$$\frac{TC}{TC_{mid}} - \frac{TC_{id}}{TC_{id}} \cdot w_2 \leq \gamma \quad (36)$$

All other constraints are also respected, from equation (1) to equation (31). The indices  $id$  and  $mid$  correspond to ideal and non ideal solutions respectively, and represent the different ideal and non ideal points outside the Pareto curve in the goal programming methodology. In this case, the ideal value is reached by minimizing the respective objective function and the non ideal value is reached by maximizing it, with independence of the other objective. Parameters  $w_1$  and  $w_2$  represent the relative weights of each objective function. In this case, these values will be assumed equal.  $\gamma$  represents the variable to be minimized.

## 6. Case study

The model presented was applied in the city of Santiago, capital of Chile. Santiago is Chilean political, economic, and institutional center. The city is divided into 37 geo political districts with a population of six million people (INE, 2018b). Santiago is located on the hydrographic basin of the Maipo River, where the main surface water sources are the Maipo and Mapocho Rivers. Santiago has been signed as a hydric stress zone, with an average regional deficit of 11.4% (Ministry of the Interior and Public Security, 2015).

In 2016 water extracted from the source was 800 million  $m^3$ /year. 81% of this flow was obtained from surface sources and 19% from underground sources (Ministry of the Interior and Public Security, 2015). Distribution of consumption according to the different users was: (i) 49% to residential consumption; (ii) 35% to agricultural irrigation; (iii) 9% to industrial consumption; (iv) 4% to urban parks irrigation; and (v) 3% to commercial consumption (Ministry of the Interior and Public Security, 2015).

Santiago water system is composed by 30 Drinking Water Treatment Plants and 10 Wastewater Treatment Plants, all distributed in different districts. The system is represented by one large and one small drinking water treatment plant and one large and one small wastewater treatment plant. These 4 plants can treat all the real city flow, since all the plants were added in the 4 that are represented in the problem. For example, if a city consumes a total of 15  $m^3$ /s of drinking water, which is treated by 30 plants in the current system, then in the present representation the 15  $m^3$ /s are treated but by two plants, one small and one large. Small plants mainly supply small localities. In the current system there is no water recycling, all wastewater treatment plants discharge their

effluents into natural water courses.

In the paper herein, a simplified version of the problem is presented. For simplicity, the city was divided into four areas as follows: North East (NE or SL), North West (NW or GF), South East (SE or RC) and South West (SW or HF). Population was distributed geographically according to the districts demographic information (INE, 2018b). The consumption of each section is calculated as the summation of the individual consumption within each district. This division is shown in Fig. 20. In addition, only one big industrial consumption, 2 wastewater treatment plants and 2 drinking water treatment plants were considered. This is to simplify the real version of the problem and to have a first approximation. To make the problem more realistic, both types of treatment plants (large and small) were considered. However, consumption is the same as in real problem, since the districts were clustered only in fewer points, but with the same water use. Thus, the flow of the entire network is representative.

For characteristics of the different districts, including consumption, locations, costs, and losses, see Appendix 1.

## 7. Results

The MIP model of the case study has 484 constraints, 1075 variables (including 50 binary variables), and was executed in an INTEL CORE i7 7700 HQ computer with 16 GB of memory. After a CPU time of 0.125 s the result was 16.06 [ $m^3$ /s] of flow extracted from the water source and a total cost of 945,932,577[USD/year], when the weights of both functions are equal. To obtain non ideal values the corresponding objective function was maximized. However, the functions do not have an upper limit as demand constraints are only made to satisfy consumption: there is no upper bound for drinking water production. To solve this problem, demand constraints were changed to equalities only when the respective objective function was maximized. Thus equation (19) was left as equation (37) for these cases:

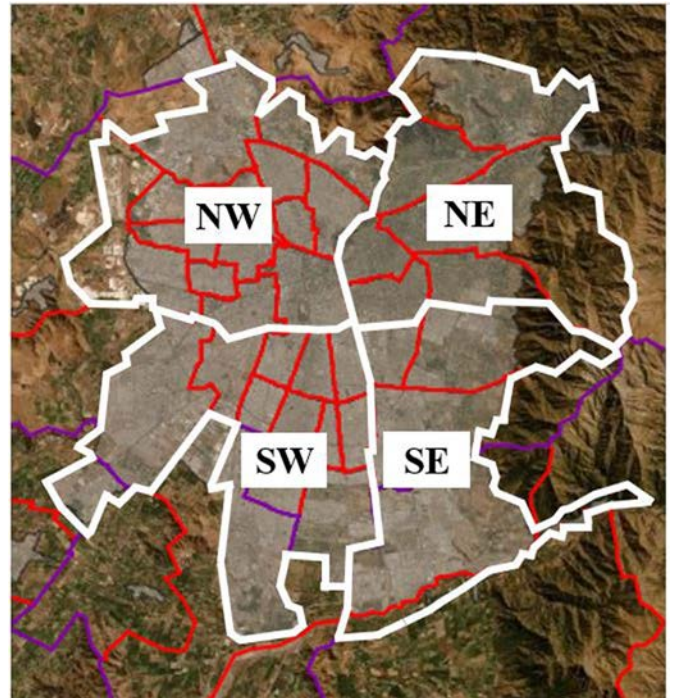


Fig. 20. Division of Santiago for the simplified version. Modified image from INE (2018a).

$$\sum_{i \in ON_j} F_{i \rightarrow j} DM_{\{j,p\}}, \forall j \in AD_j, \forall p \in CT \quad (37)$$

In this equation,  $i$  corresponds to nodes of origin of  $j$ , i.e.  $ON_j$ ;  $j$  is the current node, i.e. where the demand must be satisfied ( $AD_j$ ) being it a residential, commercial, industrial, agricultural, and urban park irrigation consumption; and  $p$  represent each district.

With the results of Table 2, the multi objective problem is formulated obtaining the Pareto curve shown in Fig. 22, where the values at the extremes of the curve were removed to make other intermediate values more clearly visible. The complete Pareto curve is shown in Fig. 21.

For equal importance in both objective functions, i.e.  $w_1 = w_2 = 0.5$  in equations (35) and (36), the superstructure shown in Fig. 24 is obtained. The mass balance for the complete system is shown in Fig. 26. This can be compared to the current base case represented by Fig. 23, where the overall mass balance is shown in Fig. 25. The optimized configuration reduces the water extraction from the natural source in 35.7%. In this solution, the annualized total cost of the water network grows a 3.2% when compared with the solution at the economic extreme of the Pareto curve, when the importance of the economic objective function is complete.

If no new or modified plants are imposed on the model, then the solution is the point where  $w_1 = 0$  and  $w_2 = 1$  on the Pareto curve, i.e. the last point on the curve with the highest value of  $G0$  and the lowest value of  $TC$ . This partially represents the current situation, since, while the treated flow is the same as when the environmental indicator is not important, the cost is higher since flows are reconfigured within the network in a suboptimal way.

In summary, a new drinking water treatment plant and a new wastewater treatment plant with drinking water output quality are installed. In addition, the two existing wastewater treatment plants in the system are modified using the general collection and distribution system. Table 3 shows a comparison between current system and optimized system.

## 8. Discussions

With respect to the obtained results, the current network is not optimal for water treatment, under the assumption that both objectives have the same importance. The optimal network takes into account the installation of a new drinking water treatment plant and a new wastewater treatment plant. It is also observed the presence of large and small plants in the case of drinking and wastewater, using the established distribution and collection networks, respectively. Both existing wastewater treatment plants are modified, and a new small plant is installed. This is mainly due to the high costs of installing new plants, compared with the modification of existing ones. The modification of plants is realistic, since installation costs are high when compared with operation costs, because of land costs. This behavior approaches other international cases such as Singapore, where there are treatment plants on the roof of other existing plants (Sembcorp Marine, 2010).

The result includes small treatment plants. According to the model, these plants distribute or collect directly from their consumers. This is a simplification, as they do not connect to a particular type of consumer. However, these plants connect to a

**Table 2**  
Results for mono-objective problems.

Variable in objective function	Ideal value	Nonideal value
Flow rate from water source: $G0$ ( $m^3/s$ )	14.67	25.59
Total Cost: $TC$ (USD/year)	940,797,564	980,974,542

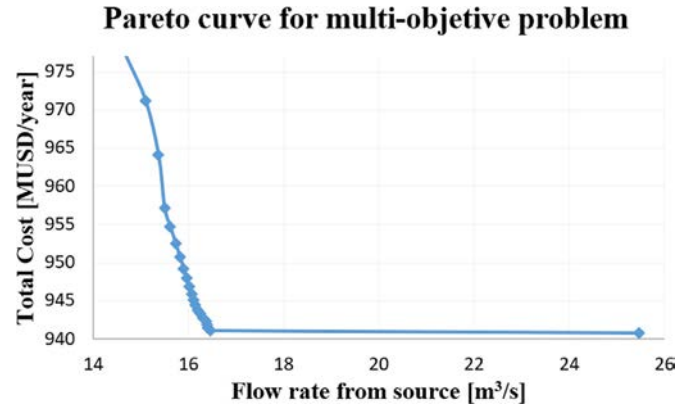


Fig. 21. Pareto curve obtained for the multi-objective problem.

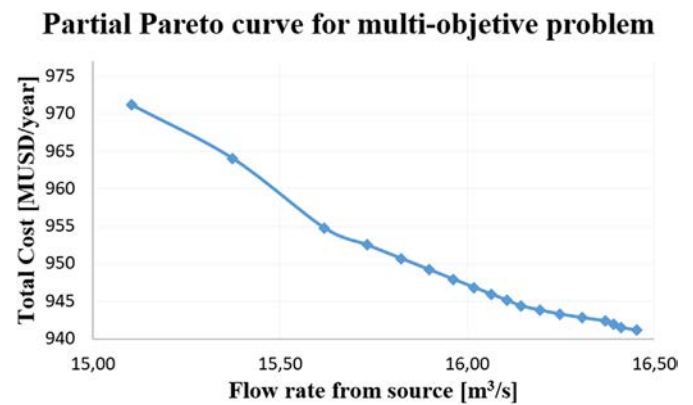
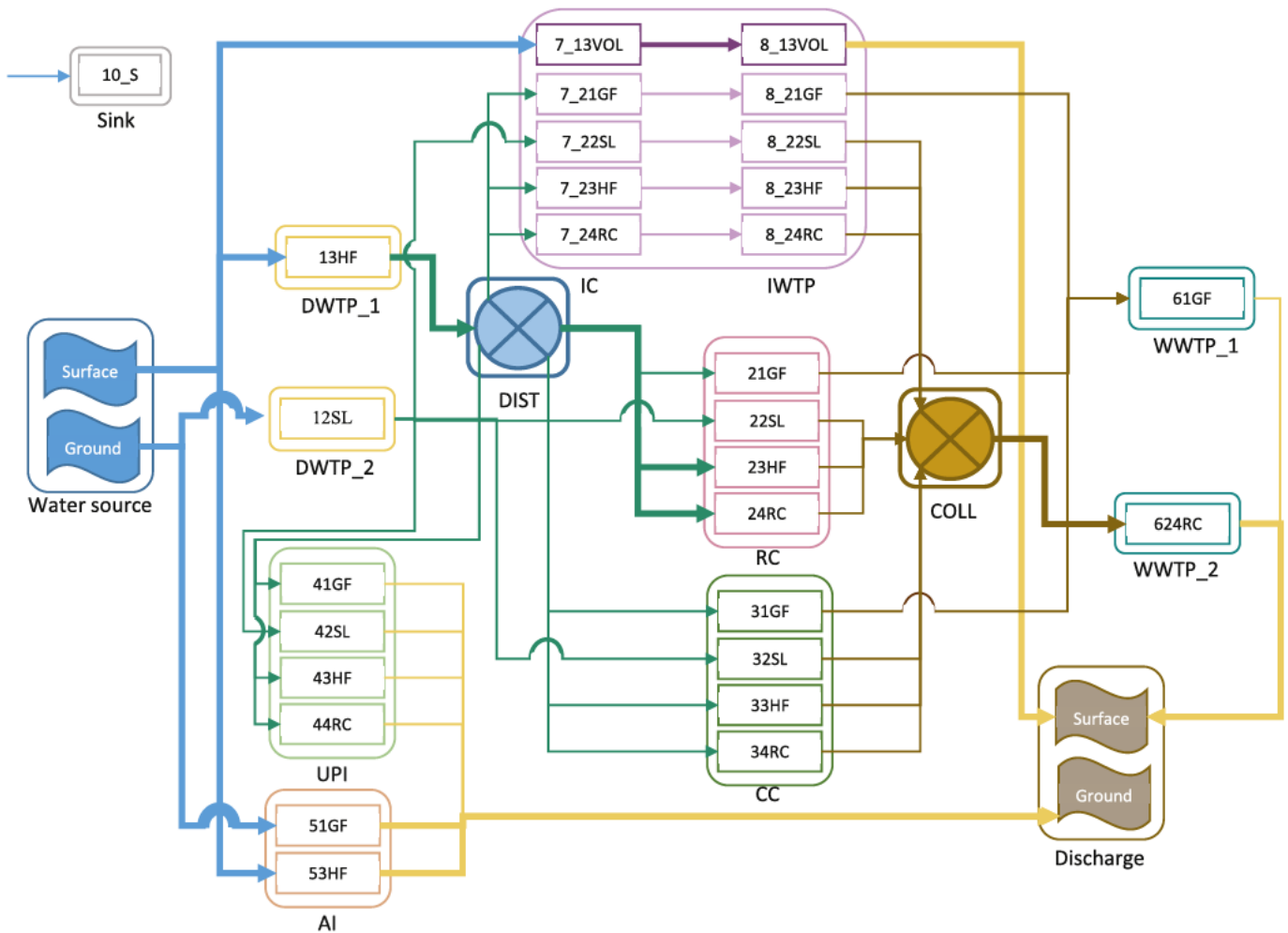


Fig. 22. Section of the Pareto curve obtained for the multi-objective problem.

small district network, which in turn connects to individual consumers. For example, commercial and residential consumption, are found in all districts ( $GF, HL, SL, RC$ ), however it is shown in Fig. 24 that the modified WWTP with drinking quality output (MWWTP1\_2) feeds the  $GF$  district consumption, while the distribution network feeds the remaining ones. Thus, the modified WWTP sends two flow rates, one towards commercial  $GF$  consumption and the other towards residential  $GF$  consumption: in order to implement, these flows are a single flow rate that is divided in the different consumption points, since they are in the same district.

The optimal result includes the installation of a new small DWTP instead of a new large DWTP, in order to supply drinking water consumers. This decision is probably due to the fact that the installation of a new small DWTP is cheaper than operating the current small plant. Another possible reason is the reduction of water losses, which are lower in small DWTPs, because they are not connected directly to distribution.

An interesting observation is that the model tries to reduce the  $G0$  and  $TC$ , so the water extracted is mainly used for irrigation and large industrial consumption, since there are no costs associated with transport, nor losses from water treatment. As there are other consumers to supply, WWTP needs to be installed or modified. There are two options: fresh water or drinking water output quality. With the first option, the flow must be connected to a DWTP plant for water treatment, so the costs and losses are higher. On the other hand, the second option allows large or small plants. The installation and modification of small WWTP reduces water losses associated with distribution and collection nodes.



RC: Residential Consumption; CC: Commercial Consumption; IC: Industrial Consumption; UPI: Urban Parks Irrigation; AI: Agricultural Irrigation. Different qualities can be observed: in light blue, source quality; in green, drinking water quality; in brown, sewer discharge quality; and in yellow, surface or underground discharge quality.

Fig. 23. Superstructure for the current situation of the city.

Existing wastewater treatment plant was modified to supply irrigation water to different consumers. This quality allows to reduce water losses, compared to fresh water quality (which is connected to a DWTP, generating an extra loss for its treatment), or to the discharge quality (which is sent directly to natural courses). The installation costs are more significant than operational costs, then the system favours the modification of existing wastewater treatment plants rather than installing new plants.

Another interesting result is that no decision is made to install wastewater treatment plants with discharge output quality. This is because it would incur in high installation costs without being able to recycle the water. In addition, no decision is made to install wastewater treatment plants with natural source output quality either. This is interesting because in many countries, water is injected into the water table to refill it with naturally filtered water (Arabi and Dawoud, 2012). Besides our model shows this solution as non optimal in environmental and economic aspects, the advantage of this type of plant is social preference, as they make an indirect reuse of the water in the network (Semcorp Marine, 2010).

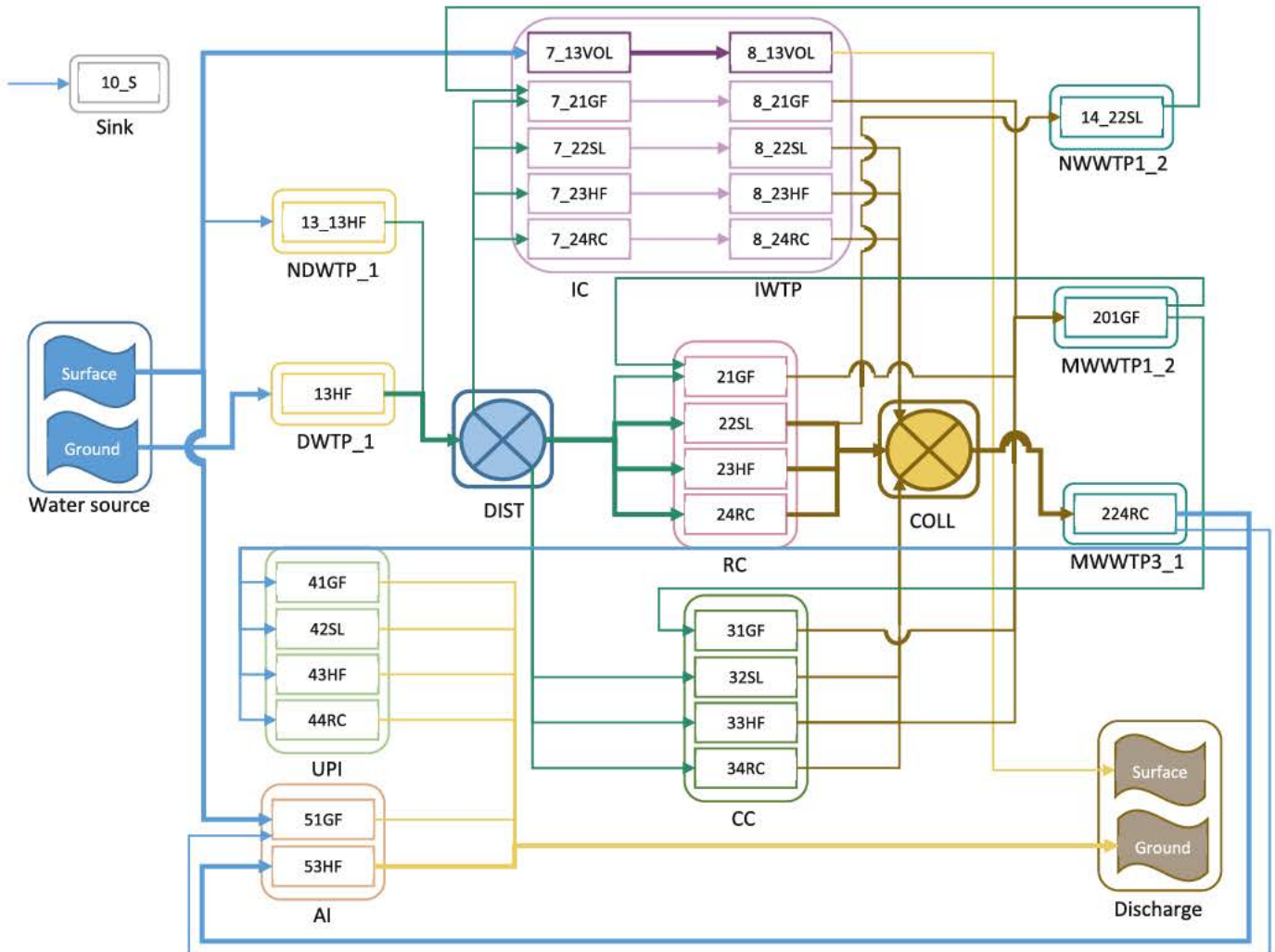
A greater number of plants could also mean a greater resilience of the system, as there would be more plants to supply the city that do not depend exclusively on the availability of water from natural

sources. However, this can be corroborated later by integrating indicators of resilience to the problem.

The Pareto curve shows the solutions for objective functions when they have different combinations of relative importance. A trade off of both functions is observed, where the relation between both functions is not direct. These functions are opposed in a different way depending on the zone in the curve in which they are located. This may be because the different solutions show respective network configurations. Moving through the Pareto curve, plants are installed or uninstalled, and this behavior is not linear. This causes some important differences in the costs of a point compared to its previous or subsequent point, visually this is observed as changes in the gradients of each point.

In the Pareto curve shown in Fig. 21 there is a kind of small step between the last value and its precedent. If the objective function depends only on the cost, then no new plants are installed, as they have a high monetary value. Current plants modified are not modified neither, because this would have an extra cost. In this case, the flow rate in the network corresponds exclusively to that extracted from the source. In consequence, the value of this variable increases dramatically when the relative importance of the cost is 100%, if compared to the previous value, when the relative importance of the cost is 95%.





RC: Residential Consumption; CC: Commercial Consumption; IC: Industrial Consumption; UPI: Urban Parks Irrigation; AI: Agricultural Irrigation. Different qualities can be observed: in light blue, source quality; in green, drinking water quality; in brown, sewer discharge quality; and in yellow, surface or underground discharge quality.

Fig. 24. Superstructure for the optimized solution with equal weights for both objective functions.



Fig. 25. Global mass balance for the current situation of the city.



Fig. 26. Global mass balance for the optimized problem with equal weights in both objective functions.

Table 3  
Results for multi-objective problem.

Plant type	Current system	Optimized system
DWTP	2	2
WWTP with discharge quality output	2	0
WWTP with potable quality output	0	2
WWTP with irrigation quality output	0	1

If new constraints are imposed to establish the base case, i.e. no new or modified plants exist and the current extraction flow is maintained, then the solution to minimize the total cost is different, because other connections are established. Hence the present situation is not optimal.

The assumptions made in the research play an important role in several areas:

- Considering steady state may not be realistic with respect to water sources, as they have different residence times than other node times. Despite this, it is not an objective of current research to study the dynamics and hydrology of water sources, so it does not affect the solutions to the problem.

- If the pollutants had been included, it would not have been necessary to differentiate between recycling treatment plants of each type, since the qualities of each plant would be given by the contaminants. However, this would have made the problem non linear, since a volumetric balance for each node would not have been sufficient, but the mass balance would have been for each contaminant for each node.
- Only network operating costs and treatment plant capital costs are considered, however, treatment plant operating costs and pipe installation costs can also be considered. These costs can change the current results and can increase the total costs. It is not possible to assure the magnitude of the cost increase or the behavior of the solutions, so it is a projection of the present research.
- The optimal solution proposes installing recycling plants. However, it is also important to consider the opinion of consumers to this type of supply. Depending on the culture of the population, they may or may not accept to consume recycled water, due to various psychological factors that this brings with it. Thus, if perception studies are not established prior to the installation of the project, it is difficult to establish a campaign to improve this aspect and make the project feasible.

As a projection, it may be important to include the choice of different types of technologies to be installed as an optimization variable, not as a given parameter according to quality. Another combination of technologies could be economically or environmentally better depending on the regional context. It is also important to improve the districts configuration. This improvement can include a mapping of pipes in order to refine transport cost estimation within the districts. This could affect the results by increasing the cost and changing the position of the plants, as distances would increase, and the optimal solution would include another configuration. Also, it is also important to analyse the linearizations of the economic indicator. While flow velocity and pipe diameter were set as parameters to reduce the computation time, there may be other ways to linearize the problem, such as linear regressions, McCormick envelopes, piecewise strategies, among others. It is possible to make the model more complex by adding other costs, such as treatment plant operating costs and pipeline installation costs.

Finally, it is planned to incorporate the limits of extraction flow through an analysis of the effects of Climate Change on different variables in Santiago. As mentioned before, the consumption of water can vary through years because of demographic pressure and Climate Change, and the sources of water could also change because of the same reason.

## 9. Conclusions

This paper deals with the management of water resources by integrating new water treatment plants to find the optimal configuration of the water network, applied to the case study of Santiago, Chile.

With parameters of demands, consumption, losses, locations, and costs, it is possible to characterize water use of the sets present in the model, which allowed to establish the optimal configuration for the problem.

The characterization of the regional water use is addressed dividing the participants within the network in sets and defining parameters as demand, consumption, losses, location, and costs. This organized structure is an important framework to look for an improved configuration of the regional water network with a formal optimization technique.

An MIP was formulated with this purpose, where the discontinuous variables were given by the existence of drinking water treatment plants and wastewater treatment plants with different output qualities, to allow water recycling within the network. This decision of allowing different qualities for water within a system is important so as to assess and compare the significant number of possible recycling and reuse connections within a city.

The problem seeks to minimize the costs of installing plants and of transporting water as well as to minimize the flow extracted from the natural source. Their respective economic and environmental indicators are defined.

To apply the methodology to Santiago, it has been necessary to separate the city into four districts in order to establish the characteristics of the different participants of the network. A Pareto curve was found with optimal solutions for different weights of each objective function. In the case in which both functions have the same importance, some ideas can be listed as an heuristic to compare possible water networks in other cities: (i) it was found that the optimal solution involves installing a new drinking water treatment plant and a new wastewater treatment plant with drinking output qualities. This solution also proposes (ii) the modification of the two existing wastewater treatment plants to reach drinking and irrigation quality outputs respectively. These results allow a reuse of water within the network, where the modification of the current WWTPs is preferred, because of the high cost of installation of new plants. For plants with drinking water quality, (iii) the use of small plants is preferred since the losses generated by distribution/collection are reduced. These results show that (iv) it is more environmentally and economically convenient to reuse water for irrigation and drinking consumption rather than recycling water to the natural source.

In the case in which both objective functions have the same importance, Santiago can reduce the water extraction from the natural source in 35.7%. In this optimal solution, the annualized total cost of the water network grows a 3.2% when compared with the economic extreme of the Pareto curve.

The model can be implemented in other contexts, allowing better planning of water resource in any city. The proposed model is a formal strategy to help decision makers to improve water resource planning for any city with simultaneous environmental and economic objectives.

Finally, the proposed model allows to include the effects of Climate Change in different variables of the problem, in order to address the uncertainty of future water availability and demand. Future study can be developed to (i) model water demands and resources as variables under uncertainty, (ii) to include new objective functions as resilience, a critical aspect when planning water networks, and (iii) to solve large scale models with a smaller grid to improve the solution detail.

## CRedit authorship contribution statement

**Felipe Díaz-Alvarado:** Conceptualization, methodology, visualization, project administration, funding acquisition. **Daniela Gormaz-Cuevas:** Model implementation, analysis, data curation, writing, review, and edition. **Javiera Riffo-Rivas:** Research, writing, supervision. **Mariana Brüning-González:** Support with Multi objective optimization of water networks and paper review. **Ludovic Montastruc:** Validation of the modeling strategy.

## Declaration of competing interest

The authors declare that they have no known competing financial interests or personal relationships that could have

appeared to influence the work reported in this paper.

## Acknowledgements

Felipe A. Díaz Alvarado wants to thank the FCFM grant *Apoyo a la Inserción Académica 2016*; University of Chile. This project was financed by *ANID/FONDECYT de Iniciación en Investigación/2017–11170042*.

southeastern district (SE). The treatment flows of the current treatment plants are shown in Table 5. In addition, factors related to water losses at each node are shown in Table 6. The locations of the elements are in Table 7. The 4 average pipe diameters are shown in Table 8, the  $Cvr_i$  parameter for the installation cost is shown in Table 9 and the  $Ter_i$  parameter for the terrain cost, is given by Table 10.

## Appendix 1. Parameters for the case study

The consumption of the different districts are shown in Table 4, where the large industrial consumption is 1.18 m<sup>3</sup>/s, located in the

**Table 4**  
Consumption of the different districts ( $DM_k$ )

District	Residential demand ( $m^3/s$ )	Commercial demand ( $m^3/s$ )	Urban park irrigation ( $m^3/s$ )	Agricultural irrigation ( $m^3/s$ )	Industrial demand ( $m^3/s$ )
NE	0.98	0.32	0.23	2.00	0.09
NW	3.52	0.31	0.27	0	0.38
SE	2.69	0.39	0.26	5.91	0.13
SW	2.76	0.42	0.31	0	0.14

**Table 5**  
Current flowrate of the treatment plants ( $AF_i$ )

Treatment plant	Present flowrate ( $m^3/s$ )
Big drinking water treatment plant (located in SE)	10.53
Small drinking water treatment plant (located in NW)	5.38
Big waste water treatment plant (located in NE)	7.76
Small waste water treatment plant (located in SW)	1.23

**Table 6**  
Water loss factors in each set

Set	Water loss factor
Big drinking water treatment plant	0.05
Small drinking water treatment plant	0.2
Big waste water treatment plant	0.05
Small waste water treatment plant	0.2
Industrial waste water treatment plant	0.05
Residential consumption	0.1
Commercial consumption	0.1
Urban park irrigation	0.55
Agricultural irrigation	0.66
Industrial consumption	0.15
Distribution	0.15
Collection	0.15

**Table 7**  
Locations of different districts, considering the lower left corner as the origin of the plan.

Set	Element	Horizontal Position X [km]	Vertical Position Y [km]	Height [m]
W	Water source in SE	124	0	787
ED	Treatment plant in SE	113.6	10.3	649
ED	Treatment plant in SE	113.6	10.3	649
ED	Treatment plant in NW	20.6	103.3	501
RC	Consumption in NE	93	93	683
RC	Consumption in NW	31	93	515
RC	Consumption in SE	93	31	616
RC	Consumption in SW	31	31	507
CC	Consumption in NE	93	93	683
CC	Consumption in NW	31	93	515
CC	Consumption in SE	93	31	616
CC	Consumption in SW	31	31	507
PC	Consumption in NE	93	93	683

(continued on next page)

**Table 7** (continued)

Set	Element	Horizontal Position X [km]	Vertical Position Y [km]	Height [m]
PC	Consumption in NW	31	93	515
PC	Consumption in SE	93	31	616
PC	Consumption in SW	31	31	507
AC	Consumption in NE	93	93	683
AC	Consumption in SE	93	31	616
EW	Treatment plant in SW	10.3	31	504
EW	Treatment plant in NE	113.6	82.6	653
IC	Big consumption in SE	72.3	20.6	634
IC	Consumption in NE	93	93	683
IC	Consumption in NW	31	93	515
IC	Consumption in SE	93	31	616
IC	Consumption in SW	31	31	507
IE	Big treatment plant in SE	72.3	20.6	634
IE	Treatment plant in NE	93	93	683
IE	Treatment plant in NW	31	93	515
IE	Treatment plant in SE	93	31	616
IE	Treatment plant in SW	31	31	507
D	Distribution	62	62	569
C	Collection	62	62	569
ND	New treatment plant in NE	124	124	1000
ND	New treatment plant in NW	0	124	490
ND	New treatment plant in SE	124	0	790
ND	New treatment plant in SW	0	0	420
NW	New treatment plant in NE	124	124	1000
NW	New treatment plant in NW	0	124	490
NW	New treatment plant in SE	124	0	790
NW	New treatment plant in SW	0	0	420
MW	Modified treatment plant in SW	10.3	31	504
MW	Modified treatment plant in NE	113.6	82.6	653

**Table 8**

Average diameters for transport cost

Diameter 1 [m]	1.8
Diameter 2 [m]	1.2
Diameter 3 [m]	1
Diameter 4 [m]	0.5

**Table 9**

$C_{vr_i}$  and  $C\bar{r}_i$  for each treatment plant

Subset	$C_{vr_i} \left[ \frac{MUSD \cdot s}{m^3} \right]$	$C\bar{r}_i [MUSD]$
NA <sup>l</sup>	2.19	54.83
NB <sup>l</sup>	1.20	44.69
NC <sup>l</sup>	1.04	34.51
ND <sup>l</sup>	1.03	34.09
NA <sup>s</sup>	3.65	3.87
NB <sup>s</sup>	2.32	3.87
NC <sup>s</sup>	1.76	2.18
ND <sup>s</sup>	1.69	2.01
MA <sup>l</sup>	1.99	1.78
MB <sup>l</sup>	1.51	1.16
MC <sup>l</sup>	0.02	0.06
MA <sup>s</sup>	2.22	2.18
MB <sup>s</sup>	0.61	1.78
MC <sup>s</sup>	0.03	0.02
NL	0.07	0.59
NS	0.05	0.63

**Table 10**

$Ter_i$  for each treatment plant

Subsets or subsets	District	$Ter_i [MUSD/year]$
NA <sup>l</sup> , NB <sup>l</sup> , NC <sup>l</sup> , ND <sup>l</sup>	GF	17.15
	SL	11.46
	HF	4.61
	RC	5.28
NA <sup>s</sup> , NB <sup>s</sup> , NC <sup>s</sup> , ND <sup>s</sup>	GF	4.29
	SL	2.87
	HF	1.15
	RC	1.32
NL	GF	5.72
	SL	3.82
	HF	1.53
NS	RC	1.76
	GF	1.43
	SL	0.95
	HF	0.38
	RC	0.44

**References**

Adham, S.S., Jacangelo, J.G., Laine, J.M., 1996. Characteristics and costs of MF and UF plants. Journal - AWWA. 88, 22 31. <https://doi.org/10.1002/j.1551-8833.1996.tb06551.x>.

Arabi, N., Dawoud, M., 2012. Groundwater aquifer recharge with treated wastewater in Egypt: technical, environmental, economical and regulatory considerations. Journal of Desalination and Water Treatment 47, 266 278. <https://doi.org/10.1080/19443994.2012.696405>.

Bagajewicz, M., Rivas, M., Savelski, M., 2000. A robust method to obtain optimal and sub-optimal design and retrofit solutions of water utilization systems with

- multiple contaminants in process plants. *Comput. Chem. Eng.* 24, 1461–1466. [https://doi.org/10.1016/S0098-1354\(00\)00413-0](https://doi.org/10.1016/S0098-1354(00)00413-0).
- Boix, M., Montastruc, L., Pibouleau, L., Azzaro-Pantel, C., Domenech, S., 2011. A multiobjective optimization framework for multicontaminant industrial water network design. *J. Environ. Manag.* 92, 1802–1808. <https://doi.org/10.1016/j.jenvman.2011.02.016>.
- Boix, M., Montastruc, L., Pibouleau, L., Azzaro-Pantel, C., Domenech, S., 2012. Industrial water management by multiobjective optimization: from individual to collective solution through eco-industrial parks. *J. Clean. Prod.* 85–97. <https://doi.org/10.1016/j.jclepro.2011.09.011>.
- Campos de Faria, D., Ulson de Souza, A.A., de Arruda Guelli Ulson de Souza, S.M., 2009. Optimization of water networks in industrial processes. *J. Clean. Prod.* 17, 857–862. <https://doi.org/10.1016/j.jclepro.2008.12.012>.
- De-León, S., Boix, M., Montastruc, L., Azzaro-Pantel, C., Liao, Z., Domenech, S., 2016. Design of a water allocation and energy network for multi-contaminant problems using multi-objective optimization. *Process Saf. Environ. Protect.* 106, 348–364. <https://doi.org/10.1016/j.psep.2016.03.015>.
- Ghosh, P., Roy, T., Majumder, C., 2016. Optimization of industrial wastewater treatment using intuitionistic fuzzy goal geometric programming problem. *Fuzzy Information and Engineering* 8, 3. <https://doi.org/10.1016/j.fiae.2016.09.002>.
- Gosling, S., Arnell, N., 2013. A global assessment of the impact of climate change on water scarcity. *Climatic Change* 135, 371–385. <https://doi.org/10.1007/s10584-013-0853-x>.
- Guo, T., Englehardt, J.D., Wu, T., 2014. Review of cost versus scale: water and wastewater treatment and reuse processes. *Water Sci. Technol. : a journal of the International Association on Water Pollution Research* 69 (2), 223–234.
- Hansen, E., Siqueira Rodrigues, M.A., Escobar, M., Monteiro, P., 2018. Water and wastewater minimization in a petrochemical industry through mathematical programming. *J. Clean. Prod.* 172, 1814–1822. <https://doi.org/10.1016/j.jclepro.2017.12.005>.
- INE, 2018a. División Política Administrativa Y Censal 2017. Instituto Nacional de Estadísticas, Chile. URL <http://ine-chile.maps.arcgis.com/apps/webappviewer/index.html?id=d0bff7af90384faa98d6ff69faa0d6d2>. Accessed: 2020-05-18.
- INE, 2018b. Síntesis de resultados CENSO 2017. Instituto Nacional de Estadísticas, Chile. URL <https://www.censo2017.cl/descargas/home/sintesis-de-resultados-censo2017.pdf>. Accessed: 2020-05-20.
- Kantor, I., Betancourt, A., Elkamel, A., Fowler, M., Almansoori, A., 2015. Generalized mixed-integer nonlinear programming modeling of eco-industrial networks to reduce cost and emissions. *J. Clean. Prod.* 99, 160–176. <https://doi.org/10.1016/j.jclepro.2015.03.017>.
- Liu, S., Flora, K., Gikas, P., Papageorgiou, L., 2011. A mixed integer optimisation approach for integrated water resources management. *Comput. Chem. Eng.* 35, 858–875. <https://doi.org/10.1016/j.compchemeng.2011.01.032>.
- Lovelady, E., El-Halwagi, M., 2009. Design and integration of eco-industrial parks for managing water resources. *Environ. Prog. Sustain. Energy* 28, 265–272. <https://doi.org/10.1002/ep.10326>.
- McGivney, W., Kawamura, S., 2008. *Cost Estimating Manual for Water Treatment Facilities*. Wiley, ISBN 9780470260036. <https://doi.org/10.1002/9780470260036>.
- Ministry of the Interior and Public Security, 2015. Presidential delegation for water resource. National policy for water resource. URL [https://www.interior.gob.cl/media/2015/04/recursos\\_hidricos.pdf](https://www.interior.gob.cl/media/2015/04/recursos_hidricos.pdf). Accessed: 2020-05-18.
- Mughees, W., Al-Ahmad, M., Naem, M., 2013. Minimizing fresh and wastewater using water pinch technique in petrochemical industries. *International Journal of Environmental, Earth Science and Engineering* 7. <https://doi.org/10.13140/2.1.1899.7445>.
- Pérez, C., Vega-Rodríguez, M., Reder, K., Florke, M., 2017. A multi-objective artificial bee colony-based optimization approach to design water quality monitoring networks in river basins. *J. Clean. Prod.* 166, 579–589. <https://doi.org/10.1016/j.jclepro.2017.08.060>.
- Pérez, S., Ponce-Ortega, J., Jiménez-Gutiérrez, A., 2019. A multi-objective optimization approach for sustainable water management for places with over-exploited water resources. *Comput. Chem. Eng.* 121, 158–173. <https://doi.org/10.1016/j.compchemeng.2018.10.003>.
- Rangaiah, G.P., 2017. *Multi-Objective Optimization*, second ed. World Scientific. <https://doi.org/10.1142/10240>. arXiv: <https://www.worldscientific.com/doi/pdf/10.1142/10240>.
- Rodríguez-Miranda, J.e.a., 2015. Analysis of the investment costs in municipal wastewater treatment plants in Cundinamarca. *Dyna* 192, 230–238. <https://doi.org/10.15446/dyna.v82n192.44699>.
- Rojas-Torres, M.G., Nápoles-Rivera, F., Guillén-Gosálbez, G., Ponce-Ortega, J., Jiménez, L., Serna-González, M., 2015. Multiobjective optimization for designing and operating more sustainable water management systems for a city in Mexico. *AIChE J.* 61, 2428–2446. <https://doi.org/10.1002/aic.14814>.
- Rubio-Castro, E., Ponce-Ortega, J.M., Serna-González, M., El-Halwagi, M., 2012. Optimal reconfiguration of multi-plant water networks into an eco-industrial park. *Comput. Chem. Eng.* 44, 58–83. <https://doi.org/10.1016/j.compchemeng.2012.05.004>.
- Sadegh, M., Tan, R., Chiu, A., 2011. MILP model for energy optimization in eip water networks. *Clean Technol. Environ. Policy* 13, 703–712. <https://doi.org/10.1007/s10098-010-0341-1>.
- Santibáñez, 2018. *El cambio climático y los recursos hídricos de Chile. In: Reflexiones Y Desafíos Al 2030. Perspectiva de Especialistas Externos*, pp. 147–178. Sembcorp Marine, 2010. Opening of Singapore's fifth and largest newwater plant, the sembcorp newwater plant. URL <https://www.sembcorp.com/en/media/media-releases/energy/2010/may/opening-of-singapores-fifth-and-largest-newwater-plant-the-sembcorp-newwater-plant/>. Accessed: 2020-05-22.
- Song, Z., 2015. The evaluation of parameter  $m$  in the big  $m$  method of linear programming. In: *International Conference on Materials Engineering and Information Technology Applications*. Atlantis Press, pp. 37–40. <https://doi.org/10.2991/meita-15.2015.8>.
- Sotelo-Pichardo, C., Ponce-Ortega, J.M., El-Halwagi, M., Sergio, F.H., 2011. Optimal retrofit of water conservation networks. *J. Clean. Prod.* 19, 1560–1581. <https://doi.org/10.1016/j.jclepro.2011.05.011>.
- Van Der Heijden, K., Stinson, C., 2019. Water Is a Growing Source of Global Conflict. world economic forum. URL <https://www.weforum.org/agenda/2019/03/water-is-a-growing-source-of-global-conflict-heres-what-we-need-to-do/>. Accessed: 2020-05-18.
- Vucetic, D., Simonovic, S., 2011. *Water Resources Decision Making under Uncertainty*. Report 73. Canadian Foundation for Climate and Atmospheric Sciences.
- Xevi, E., Khan, S., 2006. A multi-objective optimisation approach to water management. *J. Environ. Manag.* 77, 269–277. <https://doi.org/10.1016/j.jenvman.2005.06.013>.

## Glossary

### Parameters

- $DM_k$ : Water demand of node  $k$ , see Table 4  
 $AF_i$ : Current flowrate of existing plant  $i$ , see Table 5  
 $M$ : Big M, 1000000  
 $m$ : Little  $m$ , 0.02  
 $K_f$ : Factor to annualize the capital cost,  $1/20$  (year<sup>-1</sup>)  
 $T$ : Annual operating time [h-year], 8760  
 $E$ : Electricity cost [USD-kWh], 0.158  
 $F$ : Darcy coefficient [], 0.009  
 $g$ : Gravity acceleration [ $m-s^{-2}$ ], 9.8  
 $v$ : Average velocity [m-s], 1.5

### Variables

- $F_{ij}$ : Water flow from node  $i$  to node  $j$   
 $E_i$ : Existence of node  $i$   
 $\gamma$ : Variable  
 $w_i$ : Weight

### Sets

- $W$ : Set for water sources  
 $ED$ : Existing Drinking Water Treatment Plants  
 $EW$ : Existing Waste-Water Treatment Plants  
 $IE$ : Industrial Effluent Treatment Plants  
 $NDO$ : New Drinking Water Treatment Plants  
 $MW$ : Modified Waste-Water Treatment plants  
 $NW$ : New Waste-Water Treatment Plant  
 $RC$ : Residential Consumption  
 $CC$ : Commercial Consumption  
 $PC$ : Urban Park Irrigation  
 $AC$ : Agricultural Irrigation  
 $IC$ : Industrial Consumption  
 $D$ : Set for Distribution nodes  
 $C$ : Set for Collection nodes  
 $K$ : Set for discharge natural courses  
 $S$ : Sink

### Subsets

- $W^G$ : Groundwater sources  
 $W^S$ : Surface water sources  
 $DL$ : Large Existing DWTPs  
 $DS$ : Small Existing DWTPs  
 $WL$ : Large Existing WWTPs  
 $WS$ : Small Existing WWTPs  
 $PD$ : Urban Park Irrigation with drinking water consumption  
 $PF$ : Urban Park Irrigation with fresh water consumption  
 $IL$ : Large Industrial consumers  
 $IB$ : By-district Industrial consumers  
 $EL$ : Industrial Effluent Treatment Plant connected with large industrial consumers  
 $EB$ : Industrial Effluent Treatment Plant connected with by-district industrial consumers  
 $NL$ : New Large DWTPs  
 $NS$ : New Small DWTPs  
 $MA$ : Modified WWTPs with drinking water output quality  
 $MB$ : Modified WWTPs with fresh water output quality

MC: Modified WWTPs with irrigation water output quality  
 NA: New WWTPs with drinking water output quality  
 NB: New WWTPs with fresh water output quality  
 NC: New WWTPs with irrigation water output quality  
 ND: New WWTPs with discharge water output quality  
 $K^G$ : Natural groundwater discharge courses  
 $K^S$ : Natural surface discharge courses

#### Subsubsets

DG: Existing Small DWTPs with groundwater consumption  
 DS: Existing Small DWTPs with surface water consumption  
 $IL^d$ : Large Industrial consumers with drinking water consumption  
 $IL^f$ : Large Industrial consumers with fresh water consumption  
 $EL^d$ : Related to  $IL^d$   
 $EL^f$ : Related to  $IL^f$   
 $MA^l$ : Modified Large WWTPs with drinking water output quality  
 $MB^l$ : Modified Large WWTPs with fresh water output quality  
 $MC^l$ : Modified Large WWTPs with irrigation water output quality  
 $MA^s$ : Modified Small WWTPs with drinking water output quality  
 $MB^s$ : Modified Small WWTPs with fresh water output quality  
 $MC^s$ : Modified Small WWTPs with irrigation water output quality  
 $NA^l$ : New Large WWTPs with drinking water output quality  
 $NB^l$ : New Large WWTPs with fresh water output quality  
 $NC^l$ : New Large WWTPs with irrigation water output quality  
 $ND^l$ : New Large WWTPs with discharge water output quality  
 $NA^s$ : New Small WWTPs with drinking water output quality  
 $NB^s$ : New Small WWTPs with fresh water output quality  
 $NC^s$ : New Small WWTPs with irrigation water output quality  
 $ND^s$ : New Small WWTPs with discharge water output quality

#### Subsubsubsets

$IL^{ds}$ : Large Industrial consumers with drinking water consumption and sewage discharge  
 $IL^{dn}$ : Large Industrial consumers with drinking water consumption and natural water course discharge  
 $IL^{fs}$ : Large Industrial consumers with fresh water consumption and sewage discharge  
 $IL^{fn}$ : Large Industrial consumers with fresh water consumption and natural water course discharge  
 $EL^{ds}$ : Related to  $IL^{ds}$   
 $EL^{dn}$ : Related to  $IL^{dn}$   
 $EL^{fs}$ : Related to  $IL^{fs}$   
 $EL^{fn}$ : Related to  $IL^{fn}$

#### Other types of sets not included in the formulation

$ON_j$ : Origin nodes for each mass balance in the node 'j'  
 $DN_j$ : Destination nodes for each mass balance in the node 'j'  
 $AS_j$ : All set except for water sources, discharge natural courses or sink. Is the node 'j'  
 $CFW$ : Sets consuming fresh water, i.e.  $\{ED \cup NDO \cup PC \cup AC \cup IC\}$   
 $WT$ : Sets that have water losses, i.e.  $\{ED \cup EW \cup IE \cup NDO \cup MW \cup NW \cup RC \cup CC \cup PC \cup AC \cup IC \cup D \cup C\}$   
 $DNC$ : Sets that discharge water in natural courses, i.e.,  $\{EW \cup EL^{dn} \cup EL^{fn} \cup ND\}$   
 $AD_j$ : Set that includes the consumption nodes, i.e.,  $\{RC \cup C \cup PC \cup AC \cup IC\}$   
 $CT$ : Set representing each district

#### General subscripts

w: Water source node related to set W

d: Distribution node related to set D  
 c: Collection node related to set C  
 k: Discharge natural course node related to set K  
 $i_1$ : Residential consumption node related to set RC  
 $i_2$ : Commercial consumption node related to set CC  
 $h_1$ : Agricultural irrigation node related to set AC  
 $u_1$ : Urban Park Irrigation node with drinking water consumption related to subset PD  
 $u_2$ : Urban Park Irrigation node with fresh water consumption related to subset PF  
 $f_1$ : Large Industrial consumption node with drinking water consumption and sewage discharge related to subsubsubset  $IL^{ds}$   
 $f_2$ : Large Industrial consumption node with drinking water consumption and natural water course discharge related to subsubsubset  $IL^{dn}$   
 $f_3$ : Large Industrial consumption node with fresh water consumption and sewage discharge related to subsubsubset  $IL^{fs}$   
 $f_4$ : Large Industrial consumption node with fresh water consumption and natural water course discharge  $IL^{fn}$   
 $f_5$ : By-district Industrial consumption node related to IB  
 $k_0$ : Natural groundwater discharge courses related to subset  $K^G$   
 $k_1$ : Natural surface discharge courses related to subset  $K^S$

#### Treatment plants subscripts

$a_1$ : Large existing DWTP node related to subset DL  
 $a_2$ : Small existing DWTP node related to subset DS  
 $b_1$ : Large existing WWTP node related to subset WL  
 $b_2$ : Small existing WWTP node related to subset WS  
 $g_1$ : Industrial Effluent Treatment Plant node related to subsubsubset  $EL^{ds}$   
 $g_2$ : Industrial Effluent Treatment Plant node related to subsubsubset  $EL^{dn}$   
 $g_3$ : Industrial Effluent Treatment Plant node related to subsubsubset  $EL^{fs}$   
 $g_4$ : Industrial Effluent Treatment Plant node related to subsubsubset  $EL^{fn}$   
 $g_5$ : Industrial Effluent Treatment Plant node related to subset EB  
 $e_1$ : New Large DWTP node related with subset NL  
 $e_2$ : New Small DWTP node related with subset NS  
 $l_1$ : Modified Large WWTP node with drinking water output quality related to sub-subset  $MA^l$   
 $l_2$ : Modified Small WWTP node with drinking water output quality related to sub-subset  $MA^s$   
 $m_1$ : Modified Large WWTP node with fresh water output quality related to sub-subset  $MB^l$   
 $m_2$ : Modified Small WWTP node with fresh water output quality related to sub-subset  $MB^s$   
 $n_1$ : Modified Large WWTP node with irrigation water output quality related to subsubsubset  $MC^l$   
 $n_2$ : Modified Large WWTP node with irrigation water output quality related to subsubsubset  $MC^s$   
 $p_1$ : New Large WWTP node with drinking water output quality related to subsubsubset  $NA^l$   
 $p_2$ : New Small WWTP node with drinking water output quality related to subsubsubset  $NA^s$   
 $q_1$ : New Large WWTP node with fresh water output quality related to subsubsubset  $NB^l$   
 $q_2$ : New Small WWTP node with fresh water output quality related to subsubsubset  $NB^s$   
 $r_1$ : New Large WWTP node with irrigation water output quality related to subsubsubset  $NC^l$   
 $r_2$ : New Small WWTP node with irrigation water output quality related to subsubsubset  $NC^s$   
 $t_1$ : New Large WWTP node with discharge water output quality related to subsubsubset  $ND^l$   
 $t_2$ : New Small WWTP node with discharge water output quality related to subsubsubset  $ND^s$