



HAL
open science

Ku-Band Lightweight Aluminium Waveguides Fabricated by Direct Metal Laser Sintering Process

Youssef Chairi, Sarra Abedrrabba, Thomas Merlet, Allanic Rozenn, Ahmed El Oualkadi, Kamal Reklouï, Anne-Charlotte Amiaud, Cédric Quendo, Thierry Le Gouguec

► **To cite this version:**

Youssef Chairi, Sarra Abedrrabba, Thomas Merlet, Allanic Rozenn, Ahmed El Oualkadi, et al.. Ku-Band Lightweight Aluminium Waveguides Fabricated by Direct Metal Laser Sintering Process. 3rd International Symposium on Advanced Electrical and Communication Technologies: ISAECT 2020, Nov 2020, Kenitra (on line), Morocco. hal-03153508

HAL Id: hal-03153508

<https://hal.science/hal-03153508>

Submitted on 26 Feb 2021

HAL is a multi-disciplinary open access archive for the deposit and dissemination of scientific research documents, whether they are published or not. The documents may come from teaching and research institutions in France or abroad, or from public or private research centers.

L'archive ouverte pluridisciplinaire **HAL**, est destinée au dépôt et à la diffusion de documents scientifiques de niveau recherche, publiés ou non, émanant des établissements d'enseignement et de recherche français ou étrangers, des laboratoires publics ou privés.

Ku-Band Lightweight Aluminium Waveguides Fabricated by Direct Metal Laser Sintering Process

Chairi Youssef
Lab-STICC
University of Brest
Brest, France
chairi@univ-brest.fr

Rozenn Allanic
Lab-STICC
University of Brest
Brest, France
allanic@univ-brest.fr

Amiaud Anne-Charlotte
Thales LAS France SAS
Elancourt, France
[anne-
charlotte.amiaud@thalesgroup.com](mailto:anne-charlotte.amiaud@thalesgroup.com)

Abedrabba Sarra
Lab-STICC
University of Brest
Brest, France
sarra.abedrabba@arkane-tech.fr

El Oualkadi Ahmed
LabTIC
Abdelmalek Essaidi University
Tangier, Morocco
aeloualkadi@uae.ac.ma

Quando Cédric
Lab-STICC
University of Brest
Brest, France
quando@univ-brest.fr

Merlet Thomas
Thales LAS France SAS
Elancourt, France
thomas.merlet@thalesgroup.com

Reklaoui Kamal
FST
Abdelmalek Essaidi University
Tangier, Morocco
k.reklaoui@uae.ma

Le Gouguec Thierry
Lab-STICC
University of Brest
Brest, France
legouguec@univ-brest.fr

Abstract—This paper attempts to establish a good base for weight-reduction technique of microwave devices using 3D printing techniques. Experimental studies to minimize the weight of radiofrequency waveguides printed using additive manufacturing techniques are presented. Two types of Ku-band rectangular waveguides (perforated and full-metal) have been printed using direct metal laser sintering (DMLS) process. The insertion losses increased by ~1.2 dB/m after applying 1 mm grids which reduces the weight of Ku-band rectangular waveguide by ~17.5%. Comparison between these measurements and those of a waveguide manufactured by conventional method was used to determine process loss. The insertion losses of full-metal waveguide manufactured using DMLS process increase by ~0.7 dB/m compared to the conventional one. Finally, RF measurements of waveguides manufactured using DMLS process show a good agreement with the simulation results.

Keywords— 3D metal printing, Additive manufacturing, Direct metal laser sintering, Lightweight, Waveguide.

I. INTRODUCTION

Additive manufacturing (AM) technology, commonly known as 3D printing, is a production method of rising popularity in the academic research as well as in the manufacturing industry. AM techniques stay until now an opportunity for the majority of companies and at the same time a risk to manage. Regardless of the AM barriers, this new technology provides new freedom degrees for designers that are unmatched by other manufacturing methods, without the need of expensive tooling or developing thereof. This opens up for numerous opportunities especially in aeronautics such as testing ideas at low cost [1,2], lightweight parts [3,4], manufacturing of complex structures that previously would have been impossible [5]. Using direct metal laser sintering (DMLS) process known recently by powder bed fusion process according to additive manufacturing technology standards (ASTM), the object is built layer by layer from a metallic, ceramic or composite powder bed. A laser source is responsible for the consolidation by local heating.

Waveguide components have been used in communication systems for many years because of their great advantages such as: low loss and high-power handling capabilities compared to planar devices [6].

By using AM techniques, there are three methods to minimize the weight of microwave devices. The first one introduces grids in electrically non-active areas so as not to affect radiofrequency (RF) function of the device *i.e. areas with a low current line density* [7]. The second method is by metal plating on plastic 3D printed structure to form an electrically conductive surface [8,9]. However, the third method uses a monolithic structure that allows RF functions to be nested considering design freedom provided by AM techniques which gives to the designers the ability to miniaturize the RF structures at design stage [10], [11]. In contrast to the second method, the third method is valid for all AM techniques. Otherwise, the impact of the position in printing chamber as well as the environment during printing on RF structures with small RF functions such as radiating slots or coupling iris are significant, because the limitation in the resolution of DMLS process [12].

In this paper, an alternative solution offering an optimized orientation of the grids regarding the overall orientation of the RF devices during DMLS process is presented. This is experimentally demonstrated on 50 mm Ku-band rectangular waveguides. Also, two perforated waveguides with cubic grids have been printed as well as a full-metal waveguide. The RF performances of commercial waveguide have been compared, firstly, to simulation results in order to determine measurements errors except those due to air gaps, and, secondly, to the measurements of printed full-metal waveguide in order to determine the insertion losses due to DMLS process linked to both the surface roughness and dimensional accuracy. Afterwards, the measurement graphs of the full-metal waveguide have been compared to those of perforated one in order to see the impact of the grids on insertion losses. The mechanical strength is not discussed in this paper since the parts will not be mechanically stressed in the operating environment [13].

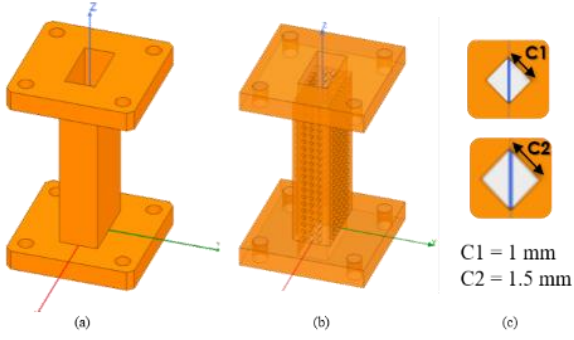

Fig. 1. Structural illustration of Ku-band waveguides designed on HFSSTM. (a) Full-metal waveguide. (b) Perforated waveguide with $C1=1$ mm. (c) Shape of cubic grids for both perforated waveguides.

II. WAVEGUIDE DESIGN AND FABRICATION

A. Design

In this paper, a full-metal waveguide and two perforated waveguides with different grids size ($C1 = 1$ mm and $C2 = 1.5$ mm) have been designed. The orientation of grids for perforated waveguides has been chosen in order to avoid printing problems during DMLS process. However, the grids respect the 45° rule for AM techniques. Taking into account this rule during the design process minimizes overhanging zones which avoid material collapsing of zones without printing supports. This proposed orientation of grids is more effective for complex RF structures with surfaces oriented vertically to the printing platform.

Overall, the sizes of grids were selected in order to keep enough material between two grids so that waveguides can hold during DMLS process.

B. Fabrication

The proposed metallic waveguides have been manufactured layer by layer from a metallic powder bed using ProX300 3D printer, under argon atmosphere. The printing material is an aluminum alloys AlSi7Mg0.6 with a layer thickness of $40 \mu\text{m}$. It is a typical metallic alloy for applications that require a combination of good electrical conductivity and lightweight. The geometry of the proposed lightweight Ku-band waveguides is shown in Fig. 1. The wall thickness of waveguides is equal to 1 mm and all have a length of 50 mm. The cross-section dimensions of printed waveguides are standardized like commercial Ku-band waveguides (WR-62 according to electronic industries alliance standards) as well as dimensions of printed flanges. The grid size was chosen taking into account the accuracy of Prox DMP 300B machine from 3D Systems used for the fabrication of the waveguides. Typically, the accuracy of Prox DMP 300B is equal to ± 0.1 mm [14].

The aluminum alloy conductivity is of 25.10^6 S/m. All printed waveguides have undergone a surface treatment by a pressure blasting machine to improve the surface quality. Both waveguides have been printed using the same design orientation and process parameters. Nevertheless, the position upon the printing platform and the environment of the printed waveguide (e.g., surrounding prototypes) are not the same. The waveguide with $C2 = 1.5$ mm grids blew up during the DMLS manufacturing process.

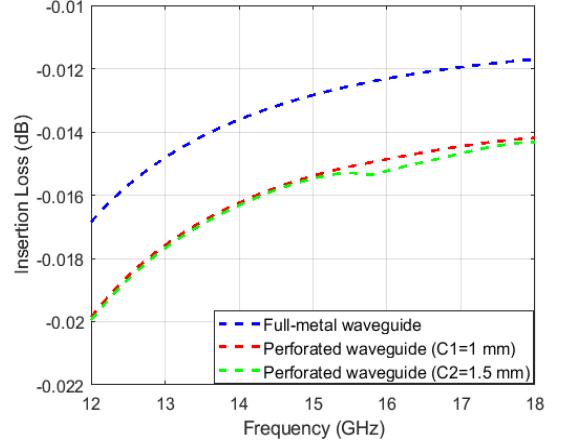

(a)

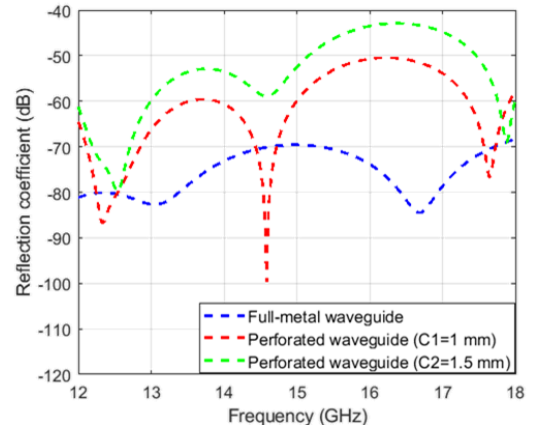

(b)

Fig. 2. Simulated S-parameters of the perforated waveguides and the full-metal waveguide. (a) Insertion loss. (b) Reflection coefficient.

III. WAVEGUIDE SIMULATION AND MEASUREMENT

A. Simulation results

In this study, the effects on RF performances of perforated waveguides were analyzed by using HFSSTM. The waveguides have been powered during simulations by two wave ports with a characteristic impedance adapted to the input impedance of the designed waveguide and have been meshed using an automatic adaptive meshing technique. A set of Ku-band (WR-62) rectangular waveguides (one solid waveguide and two perforated waveguides) are simulated. The grids are uniformly distributed over all the surfaces of perforated waveguides in order to avoid high concentration of current lines at specific area. The reflection coefficient and the insertion loss of full-metal waveguide and perforated waveguides with different size grids ($C1 = 1$ mm and $C2 = 1.5$ mm) are shown in Fig. 2. Therefore, the insertion losses increase from ~ 0.26 dB/m for full-metal waveguide to ~ 0.31 dB/m for waveguide with 1.5 mm size grids. The difference in the insertion losses between the two perforated waveguides is still negligible compared to the insertion losses of full-metal waveguide. The reflection coefficients are lower than -40 dB among Ku-band for all simulated waveguides. According to the simulation results, adding perforations in order to reduce weight of RF devices is very promising.

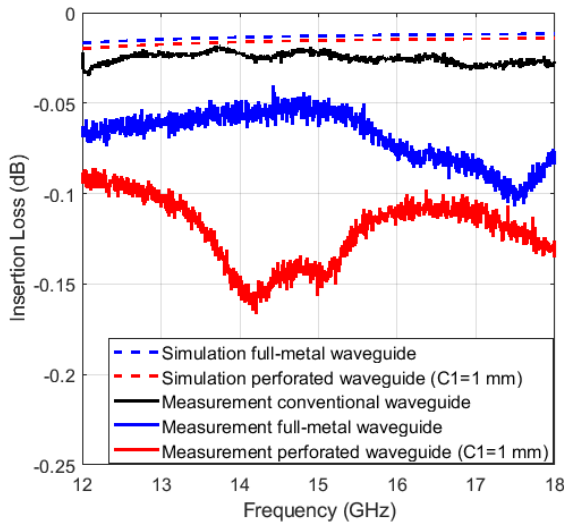

(a)

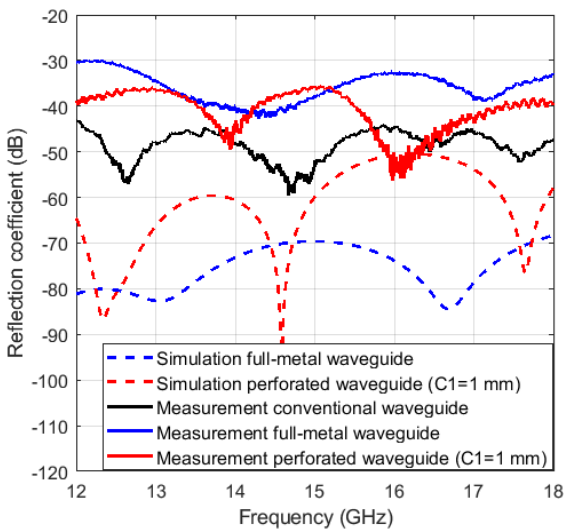

(b)

Fig. 3. Simulated and measured S-parameters of the perforated waveguide and full-metal waveguide as well as conventional waveguide. (a) Insertion loss. (b) Reflection coefficient.

B. Experimental results

The reflection coefficient and the insertion losses are measured using an Agilent N5230C network analyzer after applying a Ku-band standard TRL (Through-Reflect-Line) calibration set. The reflection coefficient and the insertion loss of measured 3D printed waveguides are shown in Fig. 3. The insertion losses of measured conventional waveguide manufactured using conventional methods are ~ 0.6 dB/m which shows that insertion losses are multiplied by 2 compared to the simulation. This increase is due to the inevitable measurement errors of misalignment of SMA connectors and waveguide flanges.

Afterwards, the insertion losses of printed full-metal waveguide manufactured by DMLS process are ~ 1.3 dB/m, which are two times greater than the insertion losses of conventional waveguide.



(a)

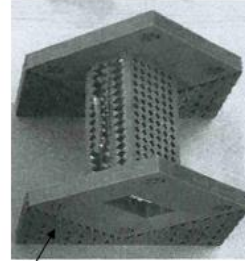

Support structure



(c)

Fig. 4. Photographs of conventional waveguide and 3D printed waveguide. (a) Conventional waveguide. (b) Orientation and support structure. (c) Exploded waveguide during DMLS process with grids size of $C2 = 1.5$ mm.

Thus, we can understand that the DMLS process increases the insertion losses mainly because of surface roughness and skin depth at Ku-band which is very low compared to the surface roughness as well as the air gaps between SMA connectors and waveguide flanges during RF measurement. A change in the electrical conductivity across the printed waveguide because of process parameters during printing process and powder quality can also increase the insertion losses.

The measured insertion losses after applying grids of 1 mm ($C1$ in Fig. 1.) to a solid waveguide are 2.5 dB/m, which means an increase of insertion losses by ~ 1.2 dB/m. The results of perforated waveguide with 45° oriented grids show more losses than full-metal waveguide, and this is unavoidable, because a part of metal is taken compared to the solid waveguide. However, the total weight of waveguide is reduced from ~ 30 g to ~ 24.75 g, corresponding to a $\sim 17.5\%$ weight reduction. Otherwise, insertion losses remain low, but they can be multiplied by more than 2 between a perforated waveguide and a solid waveguide depending on the frequency. The reflection losses are lower than -30 dB across the Ku-band for all measured waveguides printed using DMLS process.

Fig. 4. shows photographs of the conventional waveguide (WR-62) as well as the 3D printed waveguide that exploded during DMLS process attached to the printing plate and after electrical discharge machining technique which allows to separate the manufactured prototypes from the printing plate. Thus, we can also conclude that there is an upper limit for the size of grids that must be respected in order to avoid manufacturing defects according to the exploded waveguide with 1.5 mm grids size ($C2$ in Fig. 1.) shown in Fig. 4. (c). Furthermore, this limit must be much lower than the size of radiating slots in order to avoid additional radiation losses. However,

the length of radiating slots is determined according to the half-wavelength at the operating frequency as in (1).

$$\text{Length of slots} \cong \frac{\lambda(\text{operating frequency})}{2} \quad (1)$$

IV. CONCLUSION

This paper presents the design of lightweight and low-cost Ku-band rectangular waveguides. The effect of grids on waveguide electrical performances have been discussed. The insertion losses increase from ~ 1.3 dB/m to ~ 2.5 dB/m for a grid that reduces the weight by $\sim 17.5\%$. However, adding grids to waveguides produces a decrease in the electrically conductive surfaces and that has to be taken into account if we want to apply grids to complex RF structures to avoid important insertion losses. Furthermore, this work attempts to indicate the attractive potential of AM techniques in decreasing the lead time of mass producing of waveguides and also some similar RF structures such as filters and slotted waveguide antennas.

ACKNOWLEDGMENT

The authors would like to thank Thales T3DM, Ltd. for manufacturing waveguides as well as Thales LAS France SAS, Ltd. This work is carried out as part of the CIFRE-France/Morocco program. The authors would like to thank also the TECHYP platform (the High Performance Computing Cluster of the Lab-STICC) thanks to which the devices could be simulated. This publication is supported by the European Union through the European Regional Development Fund (ERDF), and by the Ministry of Higher Education and Research, Brittany Brest Métropole, through the CPER Project SOPHIE / STIC & Ondes.

REFERENCES

- [1] Y. Zhu, J. Li, and G.-L. Huang, "A Lightweight 3-D Printed Dual-Band High-Gain Slotted Spherical Antenna," *Antennas Wirel. Propag. Lett.*, vol. 19, no. 4, pp. 552–556, Apr. 2020.
- [2] J. Haumant, R. Allanic, C. Quando, D. Diedhiou, A. Manchec, C. Person, R. M. Sauvage, "Ultra-Wideband Transition From Coaxial Line to Two Parallel Lines Manufactured Using Additive Manufacturing Technology," in 2019 IEEE MTT-S International Microwave Symposium (IMS), Boston, MA, USA, pp. 1217–1220, Jun. 2019.
- [3] S. Abedrabba, R. Allanic, C. Quando, A. Quennou-Martin, J. Haumant, "Subarray Optimization for Compactness Improvement of a 3D Printed Adaptive Phased Array Antenna Operating in Ku-band," in 2019 49th European Microwave Conference (EuMC), Paris, France, pp. 1012–1015, Oct 2019.
- [4] J. Li, C. Guo, J. Xu, and L. Mao, "Lightweight low-cost Ka-band 3-D printed slotted rectangular waveguide bandpass filters," in 2017 IEEE International Symposium on Antennas and Propagation & USNC/URSI National Radio Science Meeting, San Diego, CA, USA, pp. 2647–2648, Jul. 2017.
- [5] C. Guo, J. Li, J. Xu, and H. Li, "An X-band lightweight 3-D printed slotted circular waveguide dual-mode bandpass filter," in 2017 IEEE International Symposium on Antennas and Propagation & USNC/URSI National Radio Science Meeting, San Diego, CA, USA, pp. 2645–2646, Jul. 2017.
- [6] D. M. Pozar, *Microwave Engineering*, 4th ed. Hoboken, NJ, USA: Wiley, 2012.
- [7] E. A. Rojas-Nastrucci, J. Nussbaum, T. M. Weller, and N. B. Crane, "Meshed rectangular waveguide for high power, low loss and reduced weight applications," in 2016 IEEE MTT-S International Microwave Symposium (IMS), San Francisco, CA, pp. 1–4, May 2016.
- [8] J. Li, C. Guo, J. Xu, and L. Mao, "Lightweight low-cost Ka-band 3-D printed slotted rectangular waveguide bandpass filters," in 2017 IEEE International Symposium on Antennas and Propagation & USNC/URSI National Radio Science Meeting, San Diego, CA, USA, pp. 2647–2648, Jul. 2017.
- [9] G.-L. Huang, S.-G. Zhou, C.-Y.-D. Sim, T.-H. Chio, and T. Yuan, "Lightweight Perforated Waveguide Structure Realized by 3-D Printing for RF Applications," *IEEE Trans. Antennas Propagat.*, vol. 65, no. 8, pp. 3897–3904, Aug. 2017.
- [10] O. A. Peverini, M. Lumia, G. Addamo, F. Paeonessa, G. Virone, R. Tascone, F. Galiglano, G. Cattano and D. Menfredi, "Integration of an H-Plane Bend, a Twist, and a Filter in Ku/K-Band Through Additive Manufacturing," *IEEE Trans. Microwave Theory and Technique.*, vol. 66, no. 5, pp. 2210–2219, May 2018.
- [11] K. Mouthaan and T.-H. Chio, "A 3D Printed Ku-band Waveguide Array with Integrated Waveguide Filter," in 2019 International Radar Conference, Toulon, France, pp. 1–5, Sep. 2019.
- [12] A. Guennou-Martin, Y. Quere, E. Rius, L. Fourtignon, C. Person, G. Lesueur and T. Merlet, "Design and manufacturing of a 3-D conformal slotted waveguide antenna array in Ku-band based on Direct Metal Laser Sintering," in 2016 IEEE Conference on Antenna Measurements & Applications, Syracuse, NY, USA, pp. 1–4, Oct. 2016.
- [13] D. Manfredi, F. Calignano, M. Krishnan, R. Canali, E. Ambrosio, and E. Atzeni, "From Powders to Dense Metal Parts: Characterization of a Commercial AlSiMg Alloy Processed through Direct Metal Laser Sintering," *Materials*, vol. 6, no. 3, pp. 856–869, Mar. 2013.
- [14] 3D Systems, May 2020, "LaserForm AlSi7Mg0.6 (A)," <https://uk.3dsystems.com/materials/laserform_alsi7mg0.6-A>, (accessed May 2, 2020).