



**HAL**  
open science

# High Frequency Analysis and Small-Signal Modeling of AlGa<sub>N</sub>/Ga<sub>N</sub> HEMTs with SiO<sub>2</sub>/SiN Passivation

Moujahed Gassoumi, Abdelhamid Helali, Malek Gassoumi, Christophe Gaquière, Hassen Maaref

► **To cite this version:**

Moujahed Gassoumi, Abdelhamid Helali, Malek Gassoumi, Christophe Gaquière, Hassen Maaref. High Frequency Analysis and Small-Signal Modeling of AlGa<sub>N</sub>/Ga<sub>N</sub> HEMTs with SiO<sub>2</sub>/SiN Passivation. Silicon, 2019, 11 (1), pp.557-562. 10.1007/s12633-018-9767-6 . hal-03148960

**HAL Id: hal-03148960**

**<https://hal.science/hal-03148960v1>**

Submitted on 24 May 2022

**HAL** is a multi-disciplinary open access archive for the deposit and dissemination of scientific research documents, whether they are published or not. The documents may come from teaching and research institutions in France or abroad, or from public or private research centers.

L'archive ouverte pluridisciplinaire **HAL**, est destinée au dépôt et à la diffusion de documents scientifiques de niveau recherche, publiés ou non, émanant des établissements d'enseignement et de recherche français ou étrangers, des laboratoires publics ou privés.



Distributed under a Creative Commons Attribution 4.0 International License



# High Frequency Analysis and Small-Signal Modeling of AlGa<sub>N</sub>/Ga<sub>N</sub> HEMTs with SiO<sub>2</sub>/Si<sub>3</sub>N<sub>4</sub> Passivation

Moujahed Gassoumi<sup>1</sup> · Abdelhamid Helali<sup>1</sup> · Malek Gassoumi<sup>1,2</sup> · Christophe Gaquiere<sup>3</sup> · Hassen Maaref<sup>1</sup>

Received: 30 December 2016 / Accepted: 11 January 2018 / Published online: 2 June 2018  
© The Author(s) 2018

## Abstract

AlGa<sub>N</sub>/Ga<sub>N</sub> high electron mobility transistors (HEMTs) on Silicon substrates grown by molecular beam epitaxy have been investigated using small-signal microwave measurements, to see performance Radio-frequency of components. Passivation of HEMT devices SiO<sub>2</sub>/Si<sub>3</sub>N<sub>4</sub> a different pretreatment is used to reduce the effects of trapping and consequently has a large effect on these radio-frequency parameters. We used cold-FET and hot FET technique to extract the intrinsic and extrinsic parameters in order to show the effect passivation of parasitic elements; the parasitic capacitances, resistances and inductances. From this point we discover the extent of their impact on power and microwave performance.

**Keywords** AlGa<sub>N</sub>/Ga<sub>N</sub>/Si HEMTs · Passivation · Radio-frequency · Equivalent circuit parameters · Small signal modeling

## 1 Introduction

AlGa<sub>N</sub>/Ga<sub>N</sub> based high electron mobility transistors are excellent candidates for high frequency and high power applications [1–3]. The primary reason in the nitride gallium- based materials have wide band gaps, an efficient carrier transport, large breakdown bias voltages and strong spontaneous and piezoelectric polarization fields [4]. The direct-current and radio-frequency parameters are found to improve after passivation [5]. Modeling of AlGa<sub>N</sub>/Ga<sub>N</sub>/Si HEMTs for the subsequent design a low-noise amplifier is the objective of our study.

## 2 AlGa<sub>N</sub>/Ga<sub>N</sub>/Si HEMT Structure

The AlGa<sub>N</sub>/Ga<sub>N</sub> HEMTs under investigation are grown on silicon (111) substrate by using molecular beam epitaxy (MBE) (present some high purity). The active layers consist in a 500 nm thick of undoped AlN/AlGa<sub>N</sub> buffer, a 1.8 μm undoped Ga<sub>N</sub> channel, a 23 nm thick of undoped Al<sub>0.26</sub>Ga<sub>0.74</sub>N barrier and a 1 nm n<sup>+</sup>-Ga<sub>N</sub> cap layer. The device processing is made following conventional HEMT fabrication steps. The ohmic contact pads are patterned using e-beam lithography. Hereafter, the metallization by means of evaporated 12/200/40/100 nm Ti/Al/Ni/Au is deposited at 900 °C during 30 s. The Schottky gate is realized using 100/150 nm Mo/Au layers. On the other hand, the AlGa<sub>N</sub>/Ga<sub>N</sub> HEMTs are passivated by 100/50 nm SiO<sub>2</sub>/Si<sub>3</sub>N<sub>4</sub> with pretreatment N<sub>2</sub>O and NH<sub>3</sub>.

✉ Malek Gassoumi  
malek.gassoumi@univ-lille1.fr

<sup>1</sup> Laboratoire de Micro-Optoélectronique et Nanostructures (LMON), Université de Monastir, Faculté des Sciences, Avenue de l'environnement, 5019 Monastir, Tunisie

<sup>2</sup> College of Science, Department of Physics, Qassim University, Buraidah 51452, Saudi Arabia

<sup>3</sup> Institut d'Electronique de Microélectronique et de Nanotechnologie IEMN, Université des Sciences et Technologies de Lille, Avenue Poincaré, Cedex 59652 Villeneuve d'Ascq, France

## 3 Experimental Result

S-parameters measurement is an important step for estimating RF-performance of power component, and to extract the various parameters of linear model. Measurements of these parameters were performed under coplanar points up to 60 GHz using a vector network analyzer to characterize sam-

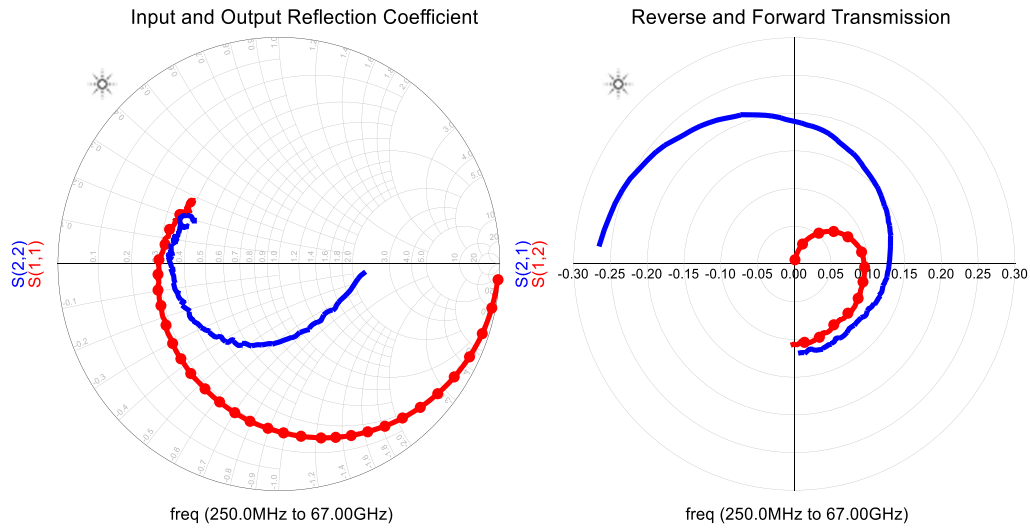

Fig. 1 Measured S-parameters before passivation of AlGaIn/GaN/Si HEMT

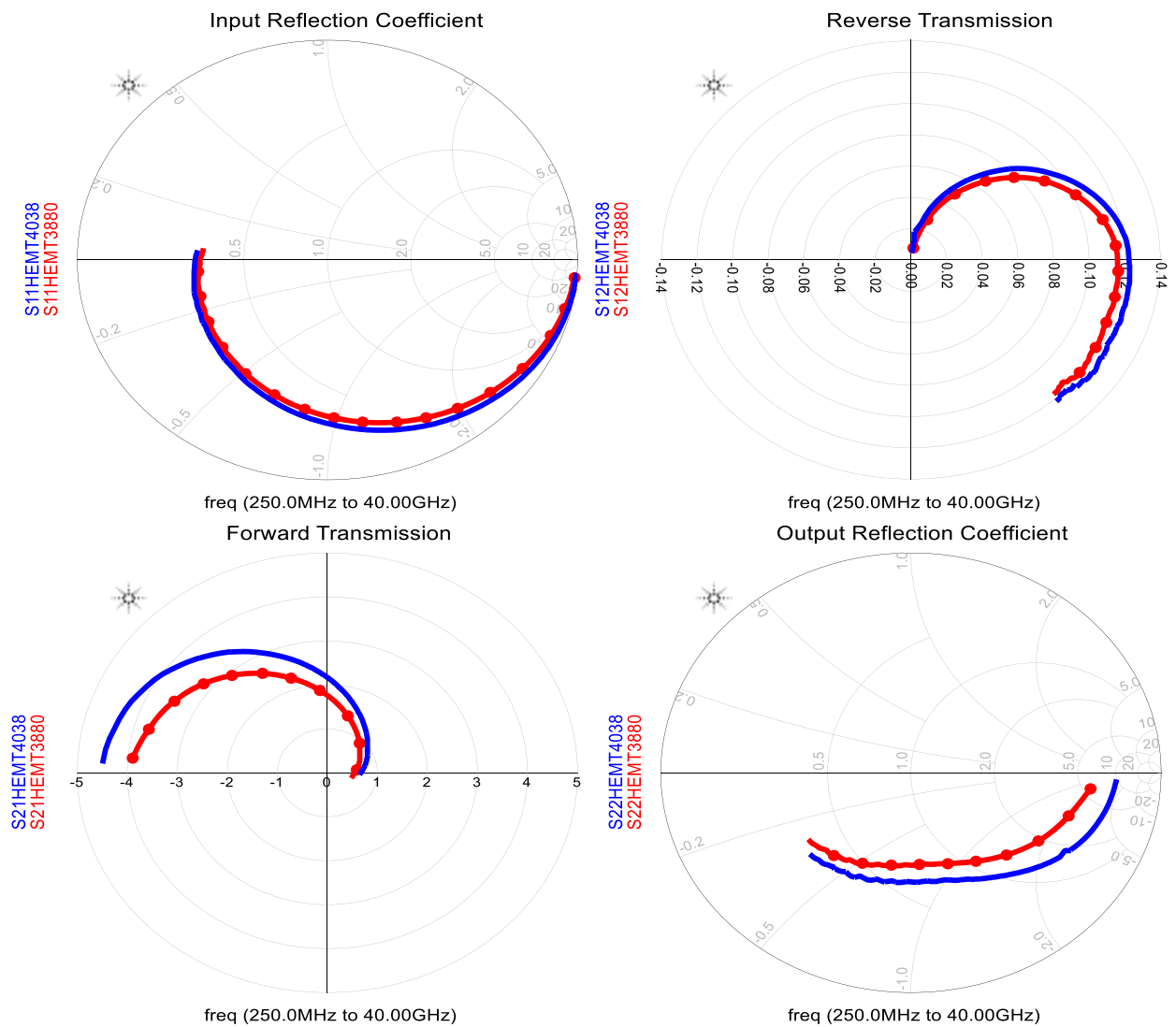
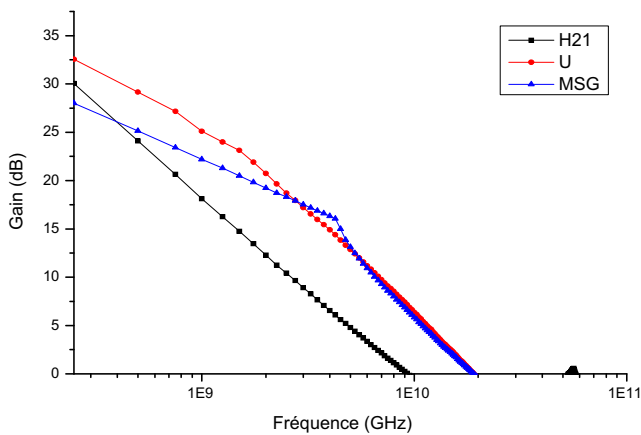

Fig. 2 Measured S-parameters after passivation and with pretreatment of AlGaIn/GaN/Si HEMT



**Fig. 3** Measured current gain ( $H_{21}$ ), unilateral power gain (U) and maximum available gain (MSG) before passivation of AlGaIn/GaN/Si HEMT

ples passivated  $\text{SiO}_2/\text{SiN}$  with  $\text{N}_2\text{O}$  and  $\text{NH}_3$  pretreatment respectively.

Figure 1 shows the experimental S-parameters of AlGaIn/GaN/Si HEMT before passivation on a frequency range extends from 250 MHz to 67 GHz in 0.25 GHz step. for a bias  $V_{gs} = -1, 25$  V and  $V_{ds} = 15$  V.

Figure 2 shows the measured scattering parameters of samples after passivation, we observe that the S-parameters spread more than before passivation Fig. 1; this change has a great influence on the performance frequency.

**Table 1** Frequency characteristics

Sample	$F_T$ (GHz)	$F_{max}$ (GHz)	$F_{MSG}$ (GHz)
Unpassivated	9,6	18,5	18,4
Passivated $\text{SiO}_2/\text{SiN}$ with $\text{NH}_3$ pretreatment	32,2	41,9	41,9
Passivated $\text{SiO}_2/\text{SiN}$ with $\text{N}_2\text{O}$ pretreatment	34,8	47,9	47,9

From on wafer S-parameters measurements, Standard extrapolations of frequency dependences of current gain ( $|H_{21}|$ ), the Mason gain (U) and maximum available gain (MSG) to higher frequencies in the shape of straight lines with the slope of -20dB/decade were used to determine their points of intersection with the frequency axis. We have deduced the frequency parameters a function of frequency ranging from 250 MHz to 60 GHz.

Figures 3 and 4 shows the gains before and after passivation for different pretreatment. The current gain and the maximum available gain to determine limits frequency of the microwave component; cut-off and maximum frequency respectively. Table 1 summarizes the main characteristics microwave.

We see from this table that passivation and surface treatment improves the performance of different frequencies. The sample passivated  $\text{SiO}_2/\text{SiN}$  with  $\text{N}_2\text{O}$  pretreatment corresponding largest frequencies; this can be explained by

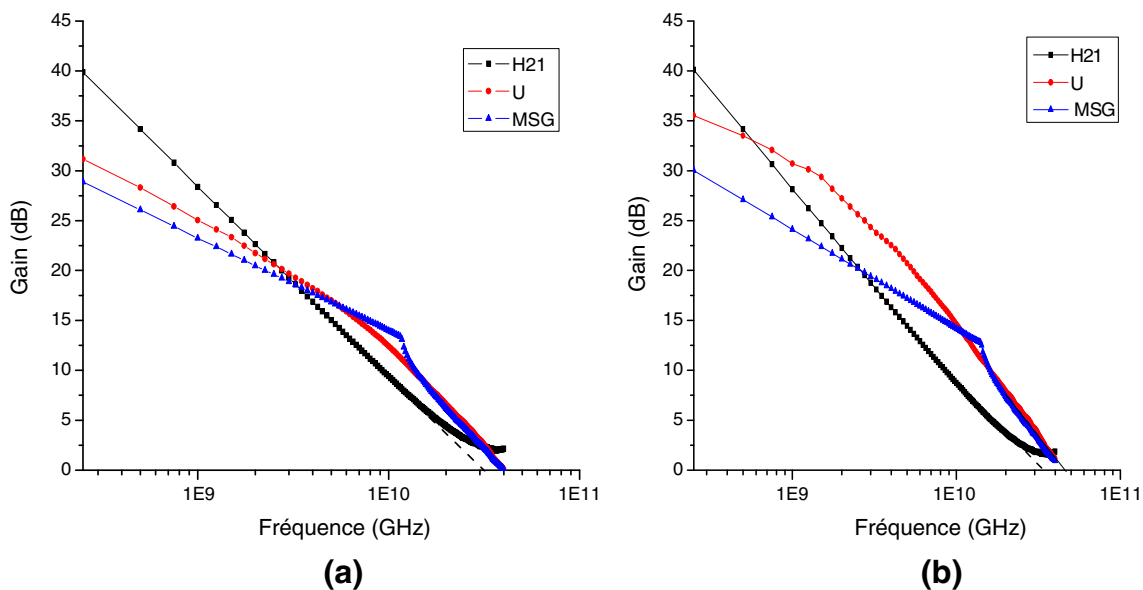

**Fig. 4** Measured current gain ( $H_{21}$ ), unilateral gain (U) and maximum available gain (MSG) after passivation of AlGaIn/GaN/Si HEMT: (a), (b)

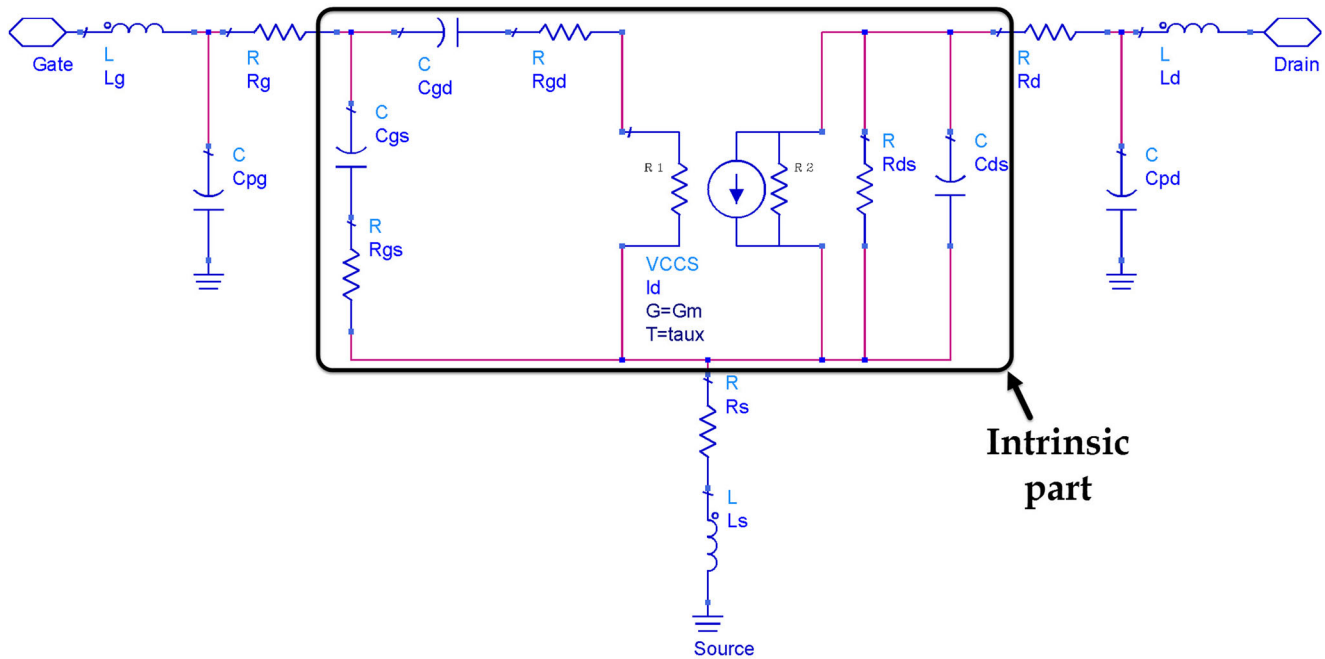

**Fig. 5** Small-signal equivalent circuit of a transistor HEMTs

the larger current as well as the higher speed of the carriers in this structure [6]. Indeed, as the structure is undoped, investors are best confined to the interface AlGa<sub>N</sub>/Ga<sub>N</sub> and do not enter a low mobility layer.

The extrinsic values  $F_t$  and  $F_{max}$  increase respectively from 9.6 GHz to 32.2 GHz for NH<sub>3</sub> pretreatment and 34.8 GHz for N<sub>2</sub>O pretreatment and 18.5 GHz to 41.9 GHz for NH<sub>3</sub> and 47.9 GHz for N<sub>2</sub>O pretreatment. Also, after passivation the  $F_{max}/F_T$  ratio is close to 1, it attests a good confinement of the charges in the channel and confirms the absence of charge coupling effects with the substrate as observed on conductive substrates [7].

#### 4 Small-Signal Modeling of AlGa<sub>N</sub>/Ga<sub>N</sub>/Si HEMT

The equivalent circuit model used for microwave HEMTs is presented in Fig. 5 [8]. It contains two parts; an intrinsic part corresponds to the active portion of the transistor and an extrinsic part outside the active region, which includes the RF contact pads and gate, drain, and source metallization.

The extraction method used is based on measurements of the small signal S-parameters, the most commonly used technique, it uses two measures S-parameters for different measuring polarization conditions; measuring cold FET and measure hot FET [9, 10].

The extrinsic equivalent circuit parameters can be evaluated from S-parameters measurements under cold and pinched conditions;  $V_{ds} = 0$  V and  $V_{gs} \ll V_p$ ,  $V_p$  is the

plucking voltage when the conduction transistor channel [10, 11]. The most common method can be categorized into analytical and optimization based.

For a game of extrinsic parameters given, one can determine the intrinsic elements from a series of matrix manipulation, comparable to a peeling process of the outer layers to reach the heart of the component [12–14].

The comparison of the measured data (circles) with simulation results (lines) for the S-parameters variation of the model before and after passivation is shown in Fig. 6. The agreements between the measured and modeled data are excellent in a wide frequency range. The extracted values for all extrinsic and intrinsic parameters are listed in Table 2.

One of the main factors affecting the gain of a FET is the feedback capacitance  $C_{gd}$ . Usually, the gate-drain capacitance is almost independent of the gate voltage it decreases with increasing drain voltage. This shows the advantage of biasing the device at larger drain voltages for better gain. Therefore, these devices have improved MSG (Maximum Stable Gain) with increasing drain bias voltage due to reduced feedback capacitance [15].

In this context, we see that this capacity decreases to 271.1 pF before passivation to reach 114.2 pF and 126.8 pF after passivation with N<sub>2</sub>O and NH<sub>3</sub> pretreatment respectively. From this point, we deduce that components with O<sub>2</sub>N pretreatment may give more power.

We observe that the gate-resistance is reduced to 7.5  $\Omega$  before passivation to up nearly half after passivation with N<sub>2</sub>O pretreatment, this has led to improve the output

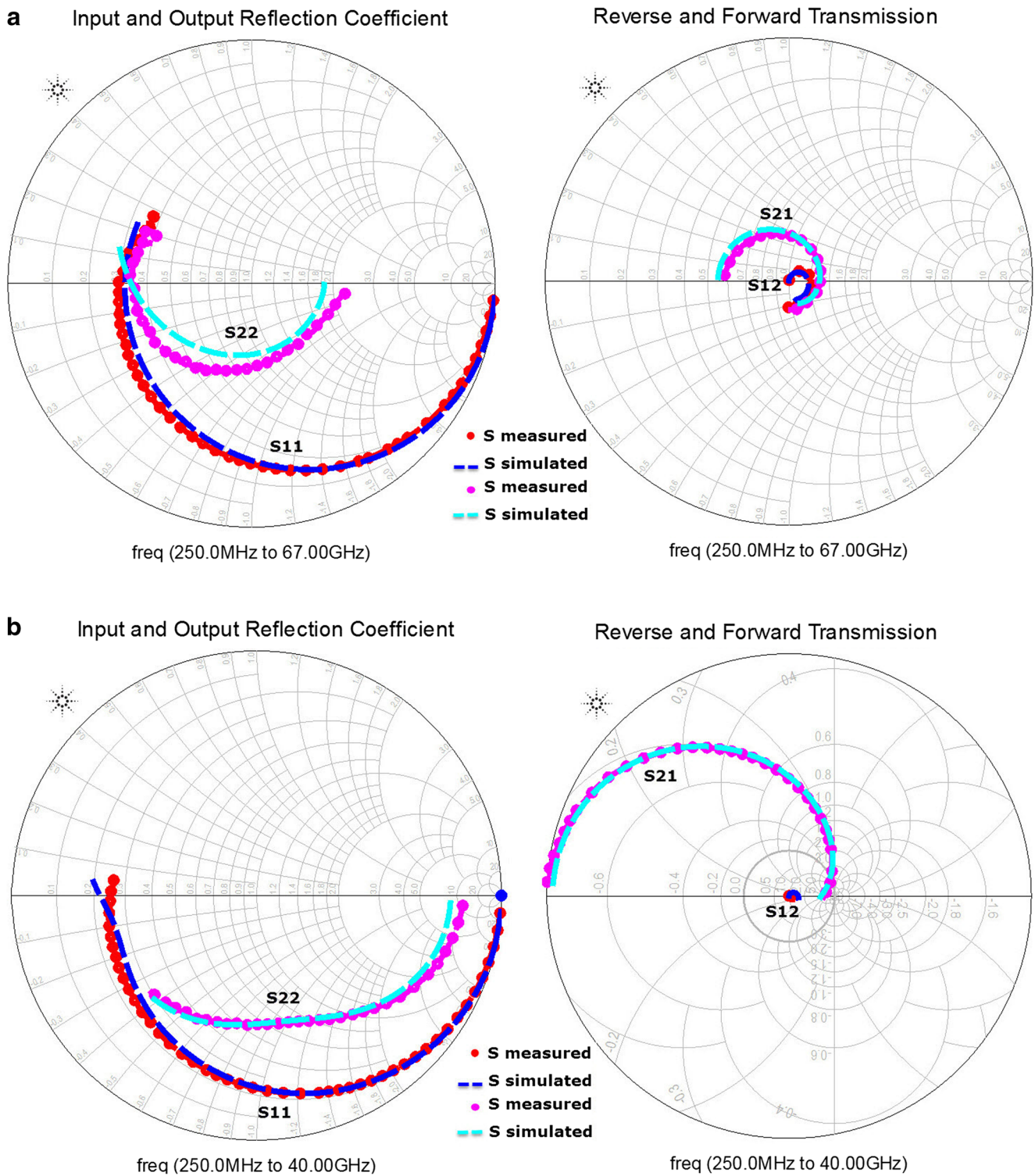

**Fig. 6** Measured (mes) and modeled (mod) S-parameters of HEMT: A—before passivation, B—after passivation

performance of AlGaIn/GaN/Si HEMT devices. Because, increasing gate resistance implies increasing the charging delay time and this results in decreasing the speed of device [16].

The RF parameters of AlGaIn/GaN/Si HEMTs are improving more after passivation by SiO<sub>2</sub>/SiN with N<sub>2</sub>O pretreatment. Then, choose this passivation with this treatment during elaboration for this type device.



**Table 2** Extracted parameters values before and after passivation a different pretreatment

Sample		Unpassivated	Passivated SiO <sub>2</sub> /SiN with NH <sub>3</sub> pretreatment	Passivated SiO <sub>2</sub> /SiN with N <sub>2</sub> O pretreatment
Extrinsic parameters	L <sub>g</sub> (pH)	44.7	37.1	36.2
	L <sub>s</sub> (pH)	10.2	6.7	5.5
	L <sub>d</sub> (pH)	92.2	27.3	59.8
	R <sub>g</sub> (Ω)	7.5	4.3	3.8
	R <sub>s</sub> (Ω)	8	3	1.5
	R <sub>d</sub> (Ω)	72.2	20.4	13.7
	C <sub>pg</sub> (fF)	30	21.5	19.6
	C <sub>pd</sub> (fF)	62.7	38.5	32.5
Intrinsic parameters	C <sub>gs</sub> (fF)	351.4	420.5	429.3
	C <sub>gd</sub> (fF)	271.1	126.8	114.2
	C <sub>ds</sub> (fF)	194.5	103.5	93.1
	R <sub>gs</sub> (Ω)	3.25	5.2	4.5
	R <sub>gd</sub> (Ω)	9.6	4.5	3.2
	R <sub>ds</sub> (Ω)	8.8	266	318
	G <sub>m</sub> (mS)	47	64	66.5
	τ (ps)	1.32	0.33	0.21

## 5 Conclusion

We have presented in this work the effect of SiO<sub>2</sub>/SiN passivation with different pretreatment on power and microwave performance, SiO<sub>2</sub>/SiN is shown to be of high quality and stoichiometric in composition. It reduces the relaxation, cracking, and surface roughness of the AlGa<sub>0.3</sub>N layer. As has been shown that as the passivation with N<sub>2</sub>O pretreatment gives better results, it makes the device more quickly and give more power. This leads to devices with greatly improved characteristics.

**Acknowledgments** The authors gratefully acknowledge Qassim University, represented by the Deanship of Scientific Research, on the material support for this research under the number (3286).

**Open Access** This article is distributed under the terms of the Creative Commons Attribution 4.0 International License (<http://creativecommons.org/licenses/by/4.0/>), which permits unrestricted use, distribution, and reproduction in any medium, provided you give appropriate credit to the original author(s) and the source, provide a link to the Creative Commons license, and indicate if changes were made.

## References

- Kumar V, Lu W, Schwindt R, Kuliev A, Simin G, Yang J, Asif Khan M, Adesida I (2002) IEEE Electron Device Lett 23:455
- Manfra MJ, Weimann N, Baeyens Y, Roux P, Tennant DM (2003) Electron Lett 39:694
- Kumar V, Kuliev A, Schwindt R, Muir M, Simin G, Yang J, Khan MA, Adesida I (2003) Solid-State Electron 47:1577
- Morkoç H (2008) Handbook of nitride semiconductors and devices, vol IeIII. Wiley-VCH, Berlin
- Mosbahi H, Gassoumi M, Saidi I, Mejri H, Gaquière C, Zaidi MA, Maaref H (2013) Curr Appl Phys 13:1359
- Gassoumi M, Mosbahi H, Soltani A, Sbrugnera-Avramovic V, Zaidi MA, Gaquière C, Mejri H, Maaref H (2013) Mater Sci Semicond Process 16:1775–1778
- Cordier Y, Semond F, Lorenzini P, Grandjean N, Natali F, Damilano B, Massies J, Hoel V, Minko A, Nellas N, Gaquière C, DeJaeger JC, Dessertene B, Cassette S, Surrugue M, Adam D, Grattepain J-C, Aubry R, Delage SL (2003) MBE Growth of AlGa<sub>0.3</sub>N/GaN HEMTS on resistive Si(111) substrate with RF small signal and power performances. Journal of Cristal Growth 251:811–815
- Dambrine G, Cappy A, Heliodore F, Playez E (1988) A new method for determining the FET small-signal equivalent circuit. IEEE Trans Microw Theory Tech 36(7):1151–1159
- Jamdal A (2005) A new small signal model parameter extraction method applied to gan devices. In: Microwave symposium digest, IEEE MTT-s international
- White PM, Healy RM (1993) Improved equivalent circuit for determination of MESFET and HEMT parasitic capacitances from cold FET measurement. IEEE Microw Guided Wave Lett 3 (december)
- Hamaizia Z, Sengouga N, Missous M, Yagoub MCE (2010) Small-signal modeling of pHEMTs and analysis of their microwave performance. J Eng Appl Sci 5(4):252–256
- Chigaeva E, Walth W, Wiegner D, Grozing M, Schaich F, Wierser N, Berroth M (2000) Determination of small signal parameters of gan based HEMTs. In: IEEE Cornell conference of high performance devices, Cornell University, Ithaca, USA, pp 115–122
- Caddemi A, Crupi G, Donato N (2016) Microwave characterization and modeling of packaged HEMTs by a direct extraction procedure down to 30 k. IEEE Trans Microw Theory Technol 55:2006
- Helali A, Noura W, Gassoumi M, Gassoumi M, Gaquière C, Maaref H (2016) Small signal modeling of HEMTs AlGa<sub>0.3</sub>N/GaN/SiC for sensor and high-temperature applications. Optik 127:7881–7888
- Therrien R, Singhal S, Johnson JW, Nagy W, Borges R, Chaudhari A, Hanson AW, Edwards A, Marquart J, Rajagopal P, Park C, Kizilyalli IC, Linthicum KJ (2005) A 36mm gan-on-si HFET producing 368w at 60v with 70% drain efficiency. In: IEEE Electron devices meeting, IEDM tech. dig., pp 568–571
- Golio JM (ed) (2003) RF And microwave semiconductor device handbook. CRC Press, Boca Raton