



**HAL**  
open science

# A sharp upper bound for the expected interval occupation time of Brownian martingales

Stefan Ankirchner, Julian Wendt

► **To cite this version:**

Stefan Ankirchner, Julian Wendt. A sharp upper bound for the expected interval occupation time of Brownian martingales. 2024. hal-03138433v2

**HAL Id: hal-03138433**

**<https://hal.science/hal-03138433v2>**

Preprint submitted on 19 Jun 2024

**HAL** is a multi-disciplinary open access archive for the deposit and dissemination of scientific research documents, whether they are published or not. The documents may come from teaching and research institutions in France or abroad, or from public or private research centers.

L'archive ouverte pluridisciplinaire **HAL**, est destinée au dépôt et à la diffusion de documents scientifiques de niveau recherche, publiés ou non, émanant des établissements d'enseignement et de recherche français ou étrangers, des laboratoires publics ou privés.

# A sharp upper bound for the expected interval occupation time of Brownian martingales

S. Ankirchner <sup>\*</sup>      J. Wendt <sup>†</sup>

May 27, 2024

## Abstract

We consider Brownian integral processes with integrands that are bounded and bounded away from zero. We provide an upper estimate for the expected occupation time in an interval. The estimate does not depend on the integrand but only on its bounds. We derive the estimate by solving a stochastic control problem that consists in maximizing the expected occupation time in an interval.

*2020 MSC* : Primary: 60H05; secondary: 93E20.

*Keywords* : occupation time in intervals; diffusion control; Brownian martingales.

## 1 Introduction and main results

Let  $(\Omega, \mathcal{F}, (\mathcal{F}_t)_{t \geq 0}, P)$  be a complete probability space that satisfies the usual conditions and supports an  $(\mathcal{F}_t)_{t \geq 0}$ -Brownian motion  $W$ . Let  $0 < \sigma_1 \leq \sigma_2$  and  $\mathbb{R}_+ := [0, \infty)$ . We denote by  $\mathcal{A}$  the set of all progressively measurable processes  $\alpha : \Omega \times \mathbb{R}_+ \rightarrow [\sigma_1, \sigma_2]$ . Let  $l, u \in \mathbb{R}$  with  $l < u$ , and  $x \in \mathbb{R}$ . Consider the class of Brownian martingales

$$X_t = x + \int_0^t \alpha_s dW_s, \quad t \in \mathbb{R}_+, \quad (1.1)$$

with  $\alpha \in \mathcal{A}$ . We provide an upper bound, independent of  $\alpha$ , for the expected time the Brownian martingale  $X$  spends in the interval  $I := [l, u]$  up to some time horizon  $t \in (0, \infty)$ . The bound depends only on  $\sigma_1, \sigma_2, l, u, x$ , and the time horizon  $t$ .

To state the main results of this paper, we define a function  $h : (0, \infty) \times \mathbb{R} \rightarrow \mathbb{R}$  by

$$h(s, x) := \sum_{k=-\infty}^{\infty} (-1)^k \frac{u - x + k(u - l)}{\sqrt{2\pi}\sigma_1 s^{\frac{3}{2}}} \exp\left(-\frac{(u - x + k(u - l))^2}{2\sigma_1^2 s}\right), \quad (1.2)$$

and a function  $\hat{g} : (0, \infty) \rightarrow \mathbb{R}$  by

$$\hat{g}(t) := \frac{1}{\pi} \int_0^\infty \frac{e^{-st}}{s} \frac{1}{\frac{\sigma_1}{\sigma_2} \cot\left(\frac{u-l}{\sqrt{2}\sigma_1} \sqrt{s}\right) + \frac{\sigma_2}{\sigma_1} \tan\left(\frac{u-l}{\sqrt{2}\sigma_1} \sqrt{s}\right)} ds, \quad t > 0. \quad (1.3)$$

For details on the functions  $h$  and  $\hat{g}$ , we refer to Remark 4.3 and Remark 4.8, respectively. The following two theorems are the main results of this paper.

---

<sup>\*</sup>Stefan Ankirchner, Institute for Mathematics, University of Jena, Ernst-Abbe-Platz 2, 07743 Jena, Germany.  
*Email*: s.ankirchner@uni-jena.de.

<sup>†</sup>Julian Wendt, Institute for Mathematics, University of Jena, Ernst-Abbe-Platz 2, 07743 Jena, Germany.  
*Email*: julian.wendt@uni-jena.de.

**Theorem 1.1.** Let  $\alpha \in \mathcal{A}$  and  $X_t = x + \int_0^t \alpha_s dW_s$ ,  $t \geq 0$ . Then, for all  $t \geq 0$

$$\int_0^t P(X_s \in [l, u]) ds \leq \begin{cases} t + \int_0^t \int_0^r (\hat{g}(r-s) - 1)h(s, x) ds dr, & \text{if } x \in (l, u), \\ \frac{d(x, I)}{\sqrt{2\pi}\sigma_2} \int_0^t \int_0^r \hat{g}(r-s) s^{-\frac{3}{2}} e^{-\frac{d(x, I)^2}{2\sigma_2^2 r}} ds dr, & \text{if } x \notin [l, u], \\ \int_0^t \hat{g}(s) ds, & \text{if } x \in \{l, u\}, \end{cases} \quad (1.4)$$

where  $d(x, I) := \inf_{y \in [l, u]} |x - y|$  denotes the distance of the point  $x$  to the interval  $I = [l, u]$ . Moreover, the bound is sharp, i.e., there exists an  $\alpha \in \mathcal{A}$  for which the inequality is an equality.

**Theorem 1.2.** Let  $\lambda > 0$ ,  $\alpha \in \mathcal{A}$ , and  $X_t = x + \int_0^t \alpha_s dW_s$ ,  $t \geq 0$ . Then

$$\int_0^\infty \lambda e^{-\lambda s} P(X_s \in [l, u]) ds \leq \begin{cases} 1 - \frac{\cosh\left(\frac{2x-(u+l)}{2\sigma_1}\sqrt{2\lambda}\right)}{\cosh\left(\frac{u-l}{2\sigma_1}\sqrt{2\lambda}\right) + \frac{\sigma_2}{\sigma_1} \sinh\left(\frac{u-l}{2\sigma_1}\sqrt{2\lambda}\right)}, & x \in [l, u], \\ \frac{1}{\frac{\sigma_1}{\sigma_2} \coth\left(\frac{u-l}{2\sigma_1}\sqrt{2\lambda}\right) + 1} \exp\left(-\frac{\sqrt{2\lambda}}{\sigma_2} d(x, I)\right), & x \notin [l, u]. \end{cases} \quad (1.5)$$

The bound is sharp, i.e., there exists an  $\alpha \in \mathcal{A}$  for which the inequality is an equality.

The problem of maximizing the occupation time in *unbounded intervals* of the form  $[l, \infty)$  or  $(-\infty, u]$  has been studied in the literature already: for Brownian martingales in [9], Remark 8, and for exponential martingales in [2]. This paper analyzes the expected occupation time within *bounded intervals*. The article [8] studies upper bounds for the expected occupation densities of Itô processes.

As in [2], we describe the upper bounds in (1.4) and (1.5) by value functions of appropriate control problems. Firstly, we prove Theorem 1.2 by considering a control problem with the control set  $\mathcal{A}$ , controlled dynamics (1.1), and the target of maximizing the *discounted* expected occupation time of  $X$  in the interval  $[l, u]$  over the whole time interval  $\mathbb{R}_+$ . We compute an explicit solution of the associated Hamilton-Jacobi-Bellman (HJB) equation, an ordinary differential equation (ODE), and solve the control problem via a verification method. We also prove that the optimal control is a feedback control that consists in choosing the maximal volatility outside the interval  $[l, u]$  and the minimal volatility inside. The optimal control attains the upper bound in (1.5).

Secondly, to prove Theorem 1.1, we consider the same control problem as above but with the aim of maximizing the expected occupation time of  $X$  in the interval  $[l, u]$  up to some *finite* time horizon  $t$ . The value function of this problem can be described in terms of its Laplace transform which is equal to the value function of the infinite time horizon problem above. Using all the properties of this function derived in Section 3 and the Laplace transform, we verify in Section 4 that a candidate function coincides with the value function. By inverting the Laplace transform, we arrive at the bound provided in Theorem 1.1. Hence, the right-hand side of (1.5) multiplied by the factor  $\frac{1}{\lambda^2}$  is the Laplace transform of the right-hand side of (1.4).

As a corollary of Theorem 1.2, we obtain the following result:

**Corollary 1.3.** Let  $x \in \mathbb{R}$ ,  $\alpha \in \mathcal{A}$ , and  $\tau : \Omega \rightarrow \mathbb{R}_+$  be an exponentially distributed random variable with parameter  $\lambda > 0$ . Let  $X_t = x + \int_0^t \alpha_s dW_s$ ,  $t \geq 0$ . We assume that  $\tau$  and  $X$  are independent. Then,  $X_\tau$  is absolutely continuous w.r.t. the Lebesgue measure on  $\mathbb{R}$ .

The proof of Corollary 1.3 is postponed to Section 5. Note that in general the law of the process  $X$  at time  $t \geq 0$  is not absolutely continuous w.r.t. the Lebesgue measure on  $\mathbb{R}$ . Fabes and Kenig [5] give a counterexample of a process  $X$  with diffusion coefficient  $\alpha_s = a(s, X_s)$ , where  $a$  is uniformly continuous, bounded and uniformly bounded away from zero. We refer to the introduction of [10] for further details.

By dividing the right-hand sides of (1.4) and (1.5) and by  $(u - l)$  and letting  $l$  converge to  $u$ , one can derive bounds on the expected occupation density, the space density of the expected occupation time. One can verify that the bounds coincide with the bounds in [8] for the martingale case. We remark that the bounds in [8] apply not only to Brownian martingales, but also to diffusions with non-vanishing drift. The bounds in [8] are derived directly with the help of a control theoretical model tailored to the problem.

By integrating the density bounds of [8] over  $[l, u]$ , one obtains also an upper bound for the expected occupation time within the interval  $[l, u]$ . The bounds derived this way, however, will be larger than the bounds of Theorem 1.1 and 1.2, respectively. One explanation is that the density bound at any point  $x$  can be attained with a sequence of diffusion coefficients that depends on  $x$ . The integrated density bound cannot be attained by a sequence of coefficients anymore, in contrast to the bounds of Theorem 1.1 and 1.2. To give a more rigorous argument, consider the bound (1.5) in the case  $x < l$ . For  $u \rightarrow \infty$ , the bound converges to  $\frac{\sigma_2}{\sigma_1 + \sigma_2} \exp(-\frac{\sqrt{2\lambda}}{\sigma_2}(l - x))$ . The density bound of Lemma 2.1 in [8], integrated over  $[u, \infty)$ , provides the integral occupation bound  $\frac{\sigma_2^2}{2\sigma_1^2} \exp(-\frac{\sqrt{2\lambda}}{\sigma_2}(l - x))$ . Notice that  $\frac{\sigma_2}{\sigma_1 + \sigma_2} < \frac{\sigma_2^2}{2\sigma_1^2}$ . Thus, the bound (1.5) is sharper.

**Remark 1.4.** The results of this article also apply for all continuous martingales  $M$ , defined on some filtered probability space  $(\Omega', \mathcal{F}', (\mathcal{F}'_t)_{t \geq 0}, P')$  satisfying the usual conditions, with quadratic variation that satisfies

$$\langle M, M \rangle_t = \int_0^t A_s ds, \quad t \geq 0, \quad P'\text{-a.s.},$$

for some progressively measurable  $A : \Omega' \times \mathbb{R}_+ \rightarrow [A^-, A^+]$ , where  $0 < A^- \leq A^+$ . This means, the quadratic variation of  $M$  is an absolutely continuous function of  $t$ ,  $P'$ -a.s. Its derivative is bounded and uniformly bounded away from zero. Indeed, Theorem 3.4.2 and Remark 3.4.3 in [6] imply that there exists a Brownian motion  $B$  on  $(\Omega', \mathcal{F}', (\mathcal{F}'_t)_{t \geq 0}, P')$  such that

$$M_t = \int_0^t \sqrt{A_s} dB_s, \quad t \geq 0, \quad P'\text{-a.s.}$$

Therefore, the process  $M$  falls into the class of Brownian martingales considered in this paper.

**Notation 1.5.** We write  $\mathcal{C}(D)$  for the set of continuous functions  $f : D \rightarrow \mathbb{R}$  where  $D \subseteq \mathbb{R}^n$ . For some open set  $D \subseteq \mathbb{R}$ ,  $\mathcal{C}^1(D)$  denotes the set of functions  $f \in \mathcal{C}(D)$  with continuous derivative  $f' \in \mathcal{C}(D)$ . Moreover,  $\mathcal{C}^{k,l}((0, t) \times \mathbb{R})$  is the set of functions  $f \in \mathcal{C}((0, t) \times \mathbb{R})$  with continuous partial derivatives  $\frac{\partial^n f}{\partial t^n}, \frac{\partial^m f}{\partial x^m} \in \mathcal{C}((0, t) \times \mathbb{R})$  for  $1 \leq n \leq k$  and  $1 \leq m \leq l$ . Lastly, we write  $\mathcal{C}^{0,l}((0, t) \times \mathbb{R})$  for the set of functions  $f \in \mathcal{C}((0, t) \times \mathbb{R})$  with continuous partial derivatives  $\frac{\partial^n f}{\partial x^n} \in \mathcal{C}((0, t) \times \mathbb{R})$  for  $1 \leq n \leq l$ . We allow  $t = \infty$  in the definitions above.

## 2 A control problem with finite time horizon

In this section, we describe the control problem, in the setting of Section 1, that we use for deriving the occupation time bound given in Theorem 1.1. The optimal control is the strategy attaining the bound in Theorem 1.1. For every  $x \in \mathbb{R}$  and  $\alpha \in \mathcal{A}$ , we denote by  $X^{x,\alpha}$  the process defined by

$$X_t^{x,\alpha} = x + \int_0^t \alpha_u dW_u, \quad t \geq 0.$$

For a fixed time horizon  $t \geq 0$ , we consider the problem of maximizing the occupation time of the process  $X^{x,\alpha}$  in the interval  $[l, u]$  up to time  $t$ . In other words, we want to maximize the target function

$$J(t, x, \alpha) := \int_0^t P(X_s^{x,\alpha} \in [l, u]) ds,$$

over all  $\alpha \in \mathcal{A}$ , and determine the value function

$$v(t, x) := \sup_{\alpha \in \mathcal{A}} J(t, x, \alpha), \quad (2.1)$$

for  $(t, x) \in \mathbb{R}_+ \times \mathbb{R}$ . We call a strategy  $\alpha \in \mathcal{A}$  *feedback control* if there exists a measurable function  $a : \mathbb{R} \rightarrow [\sigma_1, \sigma_2]$  such that  $\alpha_s = a(X_s^{x,a})$  where  $X^{x,a}$  denotes the solution to the SDE

$$dX_r = a(X_r)dW_r, \quad X_0 = x. \quad (2.2)$$

Note that a strong solution of (2.2) exists:  $a$  is uniformly bounded away from zero and hence, there exists a weak solution to (2.2) according to [7], Theorem 2.6.1. Moreover, pathwise uniqueness applies because of results in [11] and thus, there exists a unique strong solution to (2.2) (see [6], Section 5.3).

We show that it is optimal to choose the maximal volatility if the process is outside the interval  $[l, u]$  and the minimal volatility if the process is inside the interval  $[l, u]$ . To give a rigorous definition, let  $\hat{a} : \mathbb{R} \rightarrow [\sigma_1, \sigma_2]$  be defined by

$$\hat{a}(x) = \begin{cases} \sigma_1, & \text{if } x \in [l, u], \\ \sigma_2, & \text{else,} \end{cases} \quad (2.3)$$

and set  $\hat{\alpha}_s := \hat{a}(X_s^{x,\hat{a}})$ ,  $s \geq 0$ . Note that  $\hat{\alpha}$  is a feedback control of bang-bang type. The following proposition provides the solution of the control problem.

**Proposition 2.1.** *The control  $\hat{\alpha}$  is an optimal control for problem (2.1). The value function is given by the right-hand side of (1.4), i.e.,*

$$v(t, x) = \begin{cases} t + \int_0^t \int_0^r (\hat{g}(r-s) - 1)h(s, x) ds dr, & \text{if } x \in (l, u), \\ \frac{d(x, I)}{\sqrt{2\pi}\sigma_2} \int_0^t \int_0^r \hat{g}(r-s)s^{-\frac{3}{2}} \exp\left(-\frac{d(x, I)^2}{2\sigma_2^2 r}\right) ds dr, & \text{if } x \notin [l, u], \\ \int_0^t \hat{g}(s) ds, & \text{if } x \in \{l, u\}, \end{cases} \quad (2.4)$$

for  $(t, x) \in \mathbb{R}_+ \times \mathbb{R}$ . Moreover, the Laplace transform of the value function satisfies

$$\mathcal{L}[v(\cdot, x)](\lambda) = \begin{cases} \frac{1}{\lambda^2} \left( 1 - \frac{\cosh\left(\frac{2x-(u+l)}{2\sigma_1}\sqrt{2\lambda}\right)}{\cosh\left(\frac{u-l}{2\sigma_1}\sqrt{2\lambda}\right) + \frac{\sigma_2}{\sigma_1} \sinh\left(\frac{u-l}{2\sigma_1}\sqrt{2\lambda}\right)} \right), & \text{if } x \in [l, u], \\ \frac{1}{\lambda^2} \frac{1}{\frac{\sigma_1}{\sigma_2} \coth\left(\frac{u-l}{2\sigma_1}\sqrt{2\lambda}\right) + 1} \exp\left(-\frac{\sqrt{2\lambda}}{\sigma_2}d(x, I)\right), & \text{if } x \notin [l, u], \end{cases} \quad (2.5)$$

for  $\lambda > 0$  and  $x \in \mathbb{R}$ .

**Remark 2.2.** We stress that the control  $\hat{\alpha}$  does not maximize the probability of the state being in the interval  $[l, u]$  at the terminal time  $t$ . In other words, it is not an optimal control in the case of maximizing the probability  $P(X_t^{x, \hat{\alpha}} \in [l, u])$ . One can show by numerical calculations that the target function for the feedback control  $\hat{\alpha}$  does not have the required convexity and concavity properties to satisfy the HJB equation.

We postpone the proof of Proposition 2.1 to Section 4. We apply standard verification techniques to establish the optimality of  $\hat{\alpha}$  and determine the value function. The HJB equation of the control problem (2.1) is given by

$$\begin{aligned} \partial_t v(t, x) - \mathbb{1}_{[l, u]}(x) - \sup_{b \in [\sigma_1, \sigma_2]} \frac{b^2}{2} \partial_{xx} v(t, x) &= 0, \quad (t, x) \in (0, \infty) \times \mathbb{R}, \\ v(0, \cdot) &= 0. \end{aligned} \quad (2.6)$$

It is challenging to solve the HJB equation (2.6) directly. Therefore, we use the Laplace transform to turn the HJB equation into a second-order ODE. This ODE coincides with the HJB equation of a discounted infinite time horizon version of the above control problem. We first solve the infinite time horizon problem. The inverse Laplace transformation allows us to derive a candidate for the value function of the original problem.

We define

$$Q(t, x) := P(X_t^{x, \hat{\alpha}} \in [l, u]), \quad (t, x) \in \mathbb{R}_+ \times \mathbb{R}. \quad (2.7)$$

**Remark 2.3.** The function  $Q(t, \cdot)$  is symmetric in the point  $\frac{l+u}{2}$  because the distribution of  $X^{x, \hat{\alpha}}$  is symmetric around  $\frac{l+u}{2}$ , i.e.,  $Q(t, \frac{l+u}{2} + x) = Q(t, \frac{l+u}{2} - x)$  for all  $(t, x) \in \mathbb{R}_+ \times \mathbb{R}$ ,

We use the function  $Q$  to determine a candidate for the value function. In particular, we aim at showing that  $w(x) = \int_0^t Q(s, x) ds$  coincides with the value function. Hence, it suffices to determine  $Q$  (or a suitable version  $\hat{Q}$ ) and verify that  $w$  coincides with the value function to show that  $\hat{\alpha}$  is optimal. To this end, we study the Laplace transform  $\mathcal{L}[Q(\cdot, x)]$ . Note that

$$\mathcal{L}[Q(\cdot, x)](\lambda) = \int_0^\infty e^{-\lambda t} Q(t, x) dt = \int_0^\infty e^{-\lambda t} P(X_t^{x, \hat{\alpha}} \in [l, u]) dt, \quad \lambda > 0.$$

The right-hand side of this equation is related to an infinite time horizon control problem with discounted rewards. We study this problem in the next section.

### 3 A control problem with infinite time horizon

Let  $\lambda > 0$ . We define for any control  $\alpha \in \mathcal{A}$  the target function

$$K(x, \alpha, \lambda) := \int_0^\infty e^{-\lambda t} P(X_t^{x, \alpha} \in [l, u]) dt, \quad x \in \mathbb{R}, \quad (3.1)$$

where the process  $X^{x, \alpha}$  is governed by the SDE

$$dX_t^{x, \alpha} = \alpha_t dW_t, \quad X_0 = x, \quad \alpha \in \mathcal{A}.$$

Moreover, we define the value function by

$$V(x, \lambda) := \sup_{\alpha \in \mathcal{A}} K(x, \alpha, \lambda), \quad x \in \mathbb{R}. \quad (3.2)$$

For the sake of simplicity, we sometimes write  $V(x)$  and  $K(x, \alpha)$ , and omit the dependence on the parameter  $\lambda$ . The control problem consists of maximizing the target function  $K$  over all

admissible controls  $\alpha \in \mathcal{A}$ , i.e., we want to find a control  $\alpha \in \mathcal{A}$  such that  $K(x, \alpha) = V(x)$ . A control satisfying this property is called *optimal*.

As in the previous section, we suspect that the feedback control  $\hat{\alpha}_t = \hat{a}(X_t^{x,a})$  is the optimal control for (3.2), where  $\hat{a}$  is defined in (2.3). To verify this conjecture, we consider the HJB equation of (3.2), which is given by

$$\lambda V(x) - \mathbf{1}_{[l,u]}(x) - \sup_{b \in [\sigma_1, \sigma_2]} \frac{b^2}{2} V''(x) = 0, \quad x \in \mathbb{R}. \quad (3.3)$$

Note that (3.3) is an ODE in contrast to the HJB equation (2.6) of the control problem (2.1). We can even determine the solution explicitly and confirm that  $\hat{a}$  is optimal.

Assume that the value function  $V$  satisfies the HJB equation (3.3). The definition of  $K$  in (3.1) implies that  $0 \leq \lambda V(x) \leq 1$  for all  $x \in \mathbb{R}$ . Therefore,  $V$  is concave on  $[l, u]$  and convex otherwise. Moreover,  $V$  solves the following equations

$$\lambda V(x) - 1 - \frac{\sigma_1^2}{2} V''(x) = 0, \quad x \in (l, u), \quad (3.4)$$

$$\lambda V(x) - \frac{\sigma_2^2}{2} V''(x) = 0, \quad x \notin [l, u]. \quad (3.5)$$

Hence, solving (3.4) and (3.5) with appropriate constants yields a candidate for the value function  $V$ .

**Lemma 3.1.** *Let  $\beta_i := \frac{\sqrt{2\lambda}}{\sigma_i}$  for  $i = 1, 2$ . A solution of (3.4) and (3.5) is given by*

$$G(x) = \begin{cases} C_1 e^{\beta_2 x} + C_2 e^{-\beta_2 x}, & x < l \\ \frac{1}{\lambda} + C_3 e^{\beta_1 x} + C_4 e^{-\beta_1 x}, & x \in [l, u], \\ C_5 e^{\beta_2 x} + C_6 e^{-\beta_2 x}, & x > u. \end{cases}$$

The statement of Lemma 3.1 follows from straightforward calculations. For the function  $G$  in Lemma 3.1, we determine appropriate constants to construct a candidate for the value function. The boundedness of the value function, which follows directly from its definition, implies that  $C_2 = C_5 = 0$ . Moreover, the reward function  $\mathbf{1}_{[l,u]}$  is symmetric in the point  $\frac{u+l}{2}$ . The value function should inherit this symmetry (see also Remark 2.3). In addition, we require that  $G$  is contained in  $\mathcal{C}^1(\mathbb{R}) \cap \mathcal{C}^2(\mathbb{R} \setminus \{l, u\})$ . All these conditions uniquely determine the constants  $C_1, \dots, C_6$  above entailing the definition

$$G(x, \lambda) := \begin{cases} \frac{1}{\lambda} \frac{1}{\frac{\sigma_1}{\sigma_2} \coth\left(\frac{u-l}{2\sigma_1} \sqrt{2\lambda}\right) + 1} \exp\left(\frac{\sqrt{2\lambda}}{\sigma_2}(x-l)\right), & x < l, \\ \frac{1}{\lambda} \left(1 - \frac{\cosh\left(\frac{2x-(u+l)}{2\sigma_1} \sqrt{2\lambda}\right)}{\cosh\left(\frac{u-l}{2\sigma_1} \sqrt{2\lambda}\right) + \frac{\sigma_2}{\sigma_1} \sinh\left(\frac{u-l}{2\sigma_1} \sqrt{2\lambda}\right)}\right), & x \in [l, u], \\ \frac{1}{\lambda} \frac{1}{\frac{\sigma_1}{\sigma_2} \coth\left(\frac{u-l}{2\sigma_1} \sqrt{2\lambda}\right) + 1} \exp\left(-\frac{\sqrt{2\lambda}}{\sigma_2}(x-u)\right), & x > u. \end{cases} \quad (3.6)$$

**Proposition 3.2.** *We have  $V(x, \lambda) = G(x, \lambda)$  for all  $x \in \mathbb{R}$ . Moreover, the feedback control  $\hat{\alpha}_t = \hat{a}(X_t^{x,\hat{a}})$ , defined in (2.3), is optimal for (3.2).*

We emphasize that Proposition 3.2 implies the statement of Theorem 1.2 because for all controls  $\alpha \in \mathcal{A}$  we have

$$K(x, \alpha, \lambda) = \int_0^\infty e^{-\lambda t} P(X_t^{x, \alpha} \in [l, u]) dt \leq V(x, \lambda), \quad x \in \mathbb{R}.$$

*Proof.* Let  $x \in \mathbb{R}$ ,  $\alpha \in \mathcal{A}$  be an arbitrary control, and  $X$  be the associated controlled process. By Itô's formula for  $\mathcal{C}^1$  functions with absolutely continuous derivatives (see, e.g., [1] or [6], Section 3.7), we conclude that

$$e^{-\lambda t} G(X_t) = G(x) + \int_0^t e^{-\lambda s} \alpha_s G'(X_s) dW_s + \int_0^t e^{-\lambda s} \left( \frac{\alpha_s^2}{2} G''(X_s) - \lambda G(X_s) \right) ds.$$

Localizing the terms and taking expectations implies that

$$E \left[ e^{-\lambda t} G(X_t) \right] = G(x) + E \left[ \int_0^t e^{-\lambda s} \left( \frac{\alpha_s^2}{2} G''(X_s) - \lambda G(X_s) \right) ds \right]. \quad (3.7)$$

Because  $G$  is concave on  $[l, u]$  and convex on  $\mathbb{R} \setminus [l, u]$ , we see that

$$\frac{\alpha_s^2}{2} G''(x) - \lambda G(x) \leq -\mathbb{1}_{[l, u]}(x), \quad (s, x) \in \mathbb{R}_+ \times \mathbb{R} \setminus \{l, u\},$$

using that  $G$  solves the ODEs (3.4) and (3.5). Thus, we can plug this estimate into (3.7) and find that

$$E \left[ e^{-\lambda t} G(X_t) \right] \leq G(x) - \left[ \int_0^t e^{-\lambda s} P(X_s \in [l, u]) ds \right]. \quad (3.8)$$

Dominated convergence implies that the left-hand side of (3.8) converges to zero as  $t \rightarrow \infty$  because  $|G|$  is bounded by the constant  $\frac{1}{\lambda}$ . Similarly, the right-hand side of (3.8) converges to  $G(x) - V(x)$  as  $t \rightarrow \infty$ . Consequently,  $V \leq G$  because the choice of  $\alpha$  is arbitrary.

Repeating the above reasoning for  $\hat{\alpha}$  implies equality in (3.8) and  $G(x) = K(x, \hat{\alpha}) \leq V(x)$ . Finally,  $G = V$  and  $\hat{\alpha}$  is optimal.  $\square$

## 4 Connecting the control problems

We connect the control problems of Section 2 and Section 3. The definition of  $Q$  in (2.7) and Proposition 3.2 immediately entail:

**Corollary 4.1.** *It holds  $\mathcal{L}[Q(\cdot, x)](\lambda) = V(x, \lambda)$  for all  $(x, \lambda) \in \mathbb{R} \times (0, \infty)$ .*

Hence, we deduce an explicit formula for  $Q$  via the inverse Laplace transform. Let  $X^{s, x}$  denote the solution of (2.2) controlled by the feedback control  $\hat{\alpha}(X_t^{s, x})$  and starting at time  $s \geq 0$  in  $x \in \mathbb{R}$ . We define

$$g(t) := Q(t, l) = P(X_t^{l, \hat{\alpha}} \in [l, u]),$$

for  $t \geq 0$ . Note that because of symmetry, we also have  $g(t) = Q(t, u)$ ,  $t \geq 0$  (see Remark 2.3). The strong Markov property of  $X^{s, x}$  (see, e.g., [6], Theorem 5.4.20) entails that it suffices to calculate the Laplace inverse of  $V(l, \lambda)$ . This significantly reduces the complexity of the calculation of  $Q$ .



**Lemma 4.2.** For all  $(t, x) \in \mathbb{R}_+ \times \mathbb{R} \setminus \{l, u\}$ , we have

$$Q(t, x) = \begin{cases} \frac{l-x}{\sqrt{2\pi}\sigma_2} \int_0^t g(t-s) s^{-\frac{3}{2}} \exp\left(-\frac{(x-l)^2}{2\sigma_2^2 s}\right) ds, & x < l, \\ 1 + \int_0^t (g(t-s) - 1)h(s, x) ds, & x \in (l, u), \\ \frac{x-u}{\sqrt{2\pi}\sigma_2} \int_0^t g(t-s) s^{-\frac{3}{2}} \exp\left(-\frac{(x-u)^2}{2\sigma_2^2 s}\right) ds, & x > u. \end{cases} \quad (4.1)$$

**Remark 4.3.** The series  $h$ , defined in (1.2), is the probability density function of the first interval exit time of a Brownian motion with volatility  $\sigma_1$  (see proof of Lemma 4.2 for more details). It can be represented as the inverse Laplace transform

$$\begin{aligned} h(s, x) &= \sum_{k=-\infty}^{\infty} (-1)^k \frac{u-x+k(u-l)}{\sqrt{2\pi}\sigma_1 s^{\frac{3}{2}}} \exp\left(-\frac{(u-x+k(u-l))^2}{2\sigma_1^2 s}\right) \\ &= \mathcal{L}^{-1} \left[ \frac{\cosh\left(\frac{1}{2\sigma_1}(u+l-2x)\sqrt{2\cdot}\right)}{\cosh\left(\frac{1}{2\sigma_1}(u-l)\sqrt{2\cdot}\right)} \right] (s), x \in (l, u), s > 0, \end{aligned} \quad (4.2)$$

(see, e.g., [3], Appendix 2, Section 13). The series  $h$  converges uniformly on compact sets, and even the series with the differentiated summands converges (uniformly on compact sets). Therefore, we can calculate integrals or derivatives of this series by simply integrating or differentiating the summands, respectively. It holds  $h \in \mathcal{C}^{1,2}((0, \infty) \times \mathbb{R})$ .

*Proof of Lemma 4.2. Step 1.* Let  $x \in (l, u)$  and  $\tau(x)$  be the first exit time of  $X^{0,x}$  of the interval  $[l, u]$ , i.e.,  $\tau(x) := \inf\{s \geq 0 : X_s^{0,x} \notin (l, u)\}$ . Note that  $X^{0,x}$  is a Brownian motion with volatility  $\sigma_1$  up to time  $\tau(x)$ . The exit time  $\tau(x)$  has the probability density function

$$p_{\tau(x)}(s) = \mathcal{L}^{-1} \left[ \frac{\cosh\left(\frac{1}{2\sigma_1}(u+l-2x)\sqrt{2\cdot}\right)}{\cosh\left(\frac{1}{2\sigma_1}(u-l)\sqrt{2\cdot}\right)} \right] (s) = h(s, x), s > 0,$$

(see, e.g., [3], Section II.1.3). By the strong Markov property of  $X^{0,x}$ , we then have for  $t > 0$

$$\begin{aligned} Q(t, x) &= P\left(\tau(x) \leq t, X_t^{0,x} \in [l, u]\right) + P\left(\tau(x) > t, X_t^{0,x} \in [l, u]\right) \\ &= E\left[\mathbf{1}_{\{\tau(x) \leq t\}} E\left[\mathbf{1}_{[l, u]}(X_t^{0,x}) | \mathcal{F}_\tau\right]\right] + P(\tau(x) > t) \\ &= E\left[\mathbf{1}_{\{\tau(x) \leq t\}} E\left[\mathbf{1}_{[l, u]}(X_t^{s,y})\right]_{s=\tau(x), y=X_\tau}\right] + P(\tau(x) > t) \\ &= E\left[\mathbf{1}_{\{\tau(x) \leq t\}} E\left[\mathbf{1}_{[l, u]}(X_{t-s}^{0,y})\right]_{s=\tau(x), y=X_\tau}\right] + P(\tau(x) > t) \\ &= E\left[\mathbf{1}_{\{\tau(x) \leq t, X_\tau=l\}} E\left[\mathbf{1}_{[l, u]}(X_{t-s}^{0,l})\right]_{s=\tau(x)}\right] + E\left[\mathbf{1}_{\{\tau(x) \leq t, X_\tau=u\}} E\left[\mathbf{1}_{[l, u]}(X_{t-s}^{0,u})\right]_{s=\tau(x)}\right] \\ &\quad + P(\tau(x) > t) \\ &= E\left[\mathbf{1}_{\{\tau(x) \leq t, X_\tau=l\}} g(t-\tau(x))\right] + E\left[\mathbf{1}_{\{\tau(x) \leq t, X_\tau=u\}} g(t-\tau(x))\right] + P(\tau(x) > t) \\ &= E\left[\mathbf{1}_{\{\tau(x) \leq t\}} g(t-\tau(x))\right] + P(\tau(x) > t) \\ &= \int_0^t g(t-s) p_{\tau(x)}(s) ds + P(\tau(x) > t) \end{aligned}$$

$$\begin{aligned}
&= 1 + \int_0^t (g(t-s) - 1) p_{\tau(x)}(s) ds \\
&= 1 + \int_0^t (g(t-s) - 1) h(s, x) ds.
\end{aligned}$$

*Step 2.* Let  $x < l$  and  $\tau_l(x)$  be the first hitting time of  $l$  of the process  $X^{0,x}$ . Note that  $X^{0,x}$  is a Brownian motion with volatility  $\sigma_2$  up to time  $\tau_l(x)$ . The hitting time  $\tau_l(x)$  has the density

$$p_{\tau_l(x)}(t) = \frac{l-x}{\sqrt{2\pi}\sigma_2 t^{\frac{3}{2}}} \exp\left(-\frac{(x-l)^2}{2\sigma_2^2 t}\right), \quad t > 0,$$

(see, e.g., [3], Section II.1.2). Again, the strong Markov property implies that for  $t > 0$

$$\begin{aligned}
Q(t, x) &= P\left(\tau_l(x) \leq t, X_t^{0,x} \in [l, u]\right) + P\left(\tau_l(x) > t, X_t^{0,x} \in [l, u]\right) \\
&= E\left[\mathbf{1}_{\{\tau_l(x) \leq t\}} g(t - \tau_l(x))\right] \\
&= \frac{l-x}{\sqrt{2\pi}\sigma_2} \int_0^t g(t-s) s^{-\frac{3}{2}} \exp\left(-\frac{(x-l)^2}{2\sigma_2^2 s}\right) ds.
\end{aligned}$$

*Step 3.* Let  $x > u$  and  $\tau_u(x)$  be the first hitting time of  $u$  of the process  $X^{0,x}$ . The hitting time  $\tau_u(x)$  has the density

$$p_{\tau_u(x)}(t) = \frac{x-u}{\sqrt{2\pi}\sigma_2 t^{\frac{3}{2}}} \exp\left(-\frac{(x-u)^2}{2\sigma_2^2 t}\right), \quad t > 0.$$

We have for  $t > 0$

$$\begin{aligned}
Q(t, x) &= P\left(\tau_u(x) \leq t, X_t^{0,x} \in [l, u]\right) + P\left(\tau_u(x) > t, X_t^{0,x} \in [l, u]\right) \\
&= E\left[\mathbf{1}_{\{\tau_u(x) \leq t\}} g(t - \tau_u(x))\right] \\
&= \frac{x-u}{\sqrt{2\pi}\sigma_2} \int_0^t g(t-s) s^{-\frac{3}{2}} \exp\left(-\frac{(x-u)^2}{2\sigma_2^2 s}\right) ds.
\end{aligned}$$

Finally, note that the equations for  $Q$  above also extend to  $t = 0$ . □

Lemma 4.2 implies that it suffices to study the function  $g$  because  $Q$  has the representation (4.1). Moreover, we see that  $\mathcal{L}[g] = V(l, \cdot)$  by Corollary 4.1. Therefore, we can characterize  $g$  by the inverse Laplace transform of  $V(l, \cdot)$ . To identify  $g$ , we introduce the domain  $D := \mathbb{C} \setminus (-\infty, 0]$  and define the function

$$F(z) := \frac{1}{z \frac{\sigma_1}{\sigma_2} \coth\left(\frac{u-l}{\sqrt{2}\sigma_1} \sqrt{z}\right) + 1}, \quad z \in D.$$

Because the complex square root is not uniquely determined, we define

$$\sqrt{z} = \sqrt{x+iy} := \sqrt{\frac{\sqrt{x^2+y^2}+x}{2}} + i \cdot \operatorname{sgn}^+(y) \sqrt{\frac{\sqrt{x^2+y^2}-x}{2}}, \quad z = x+iy \in \mathbb{C}, \quad (4.3)$$

where  $\operatorname{sgn}^+(y) := \mathbf{1}_{[0, \infty)}(y) - \mathbf{1}_{(-\infty, 0)}(y)$ . From now on, we always understand  $\sqrt{z}$  in the sense of (4.3).

Observe that  $F(\lambda) = V(l, \lambda)$ ,  $\lambda > 0$ . Hence,  $F$  extends  $V(l, \cdot)$  to the complex domain  $D$ . We emphasize that  $F$  is well-defined and holomorphic on the domain  $D$ . Moreover:

**Lemma 4.4.**

(i) For all  $z \in D$ , we have

$$|F(z)| \leq \frac{1}{|z|}.$$

(ii)  $F$  is holomorphic on  $D := \mathbb{C} \setminus (-\infty, 0]$ .

(iii) For any  $b > 0$ , it holds

$$\lim_{r \rightarrow \infty} \int_{-r}^r F(b + is) e^{(b+is)t} ds = 2i \int_0^\infty \frac{e^{-xt}}{x} \frac{1}{\frac{\sigma_1}{\sigma_2} \cot\left(\frac{u-l}{\sqrt{2}\sigma_1} \sqrt{x}\right) + \frac{\sigma_2}{\sigma_1} \tan\left(\frac{u-l}{\sqrt{2}\sigma_1} \sqrt{x}\right)} dx, \quad t > 0.$$

In particular, the limit on the left-hand side exists and does not depend on the particular choice of  $b > 0$ . Moreover, we can pass to the limit  $b \downarrow 0$  and conclude that

$$\lim_{r \rightarrow \infty} \int_{-r}^r F(is) e^{ist} ds = 2i \int_0^\infty \frac{e^{-xt}}{x} \frac{1}{\frac{\sigma_1}{\sigma_2} \cot\left(\frac{u-l}{\sqrt{2}\sigma_1} \sqrt{x}\right) + \frac{\sigma_2}{\sigma_1} \tan\left(\frac{u-l}{\sqrt{2}\sigma_1} \sqrt{x}\right)} dx, \quad t > 0.$$

The proof is postponed to Section A. We set

$$\Gamma(z) := zF(z) - \frac{\sigma_2}{\sigma_1 + \sigma_2}, \quad z \in D. \quad (4.4)$$

**Lemma 4.5.** The function  $\Gamma$ , defined in (4.4), has the following properties:

(i)  $\Gamma$  is holomorphic on  $D$ .

(ii) For all  $x \geq 0$ , we have

$$\int_{-\infty}^\infty |\Gamma(x + iy)| dy < \infty,$$

and  $\Gamma(z) = \Gamma(x + iy)$  converges to zero as  $z = x + iy$  converges two-dimensionally to infinity in every half-plane  $x \geq 0$ .

(iii) The function  $\gamma : \mathbb{R} \rightarrow \mathbb{R}$ , defined by

$$\gamma(t) := \frac{1}{2\pi} \int_{-\infty}^\infty \Gamma(x + is) e^{its} ds, \quad t \in \mathbb{R},$$

for some  $x > 0$ , is continuous and satisfies  $\mathcal{L}[\gamma] = \Gamma$ . The definition of  $\gamma$  does not depend on the particular choice of  $x > 0$ . In addition,  $\gamma(t) = 0$ ,  $t \leq 0$ , and

$$\gamma(t) = \frac{1}{2\pi} \int_{-\infty}^\infty \Gamma(is) e^{its} ds = \frac{2}{\pi} \int_0^\infty \operatorname{Re}(\Gamma(is)) \cos(ts) ds, \quad t > 0. \quad (4.5)$$

**Remark 4.6** (cf. [4], Chapter 28). We say that a function  $f : \mathbb{C} \rightarrow \mathbb{C}$  converges in the half-plane  $\{x + iy : x \geq x_0, y \in \mathbb{R}\}$  to zero as  $z = x + iy$  converges two-dimensionally to infinity if for every  $\varepsilon > 0$ , there exists  $R > 0$  such that

$$|f(z)| \leq \varepsilon,$$

for all  $z \in \mathbb{C}$  with  $\operatorname{Re}(z) \geq x_0$  and  $|z| > R$ .

The proof of Lemma 4.5 is postponed to Section A. Recall that the function  $\hat{g}$ , defined in (1.3), is given by

$$\hat{g}(t) = \frac{1}{\pi} \int_0^\infty \frac{e^{-st}}{s} \frac{1}{\frac{\sigma_1}{\sigma_2} \cot\left(\frac{u-l}{\sqrt{2\sigma_1}}\sqrt{s}\right) + \frac{\sigma_2}{\sigma_1} \tan\left(\frac{u-l}{\sqrt{2\sigma_1}}\sqrt{s}\right)} ds, \quad t > 0. \quad (4.6)$$

We can show the following:

**Proposition 4.7.**

(i)  $\hat{g}(t) = g(t)$  for almost every  $t > 0$ , and  $\mathcal{L}[g] = \mathcal{L}[\hat{g}] = F$ .

(ii)  $\hat{g} \in \mathcal{C}^1((0, \infty))$  with  $\hat{g}' = \gamma$  and

$$\hat{g}'(t) = -\frac{1}{\pi} \int_0^\infty e^{-st} \frac{1}{\frac{\sigma_1}{\sigma_2} \cot\left(\frac{u-l}{2\sigma_1}\sqrt{2s}\right) + \frac{\sigma_2}{\sigma_1} \tan\left(\frac{u-l}{2\sigma_1}\sqrt{2s}\right)} ds, \quad t > 0. \quad (4.7)$$

(iii) The Laplace transform of  $\hat{g}'$  is given by  $\Gamma$ , i.e.,

$$\mathcal{L}[\hat{g}'](\lambda) = \Gamma(\lambda) = \lambda \mathcal{L}[\hat{g}](\lambda) - \frac{\sigma_2}{\sigma_1 + \sigma_2},$$

for  $\lambda > 0$ . Furthermore,  $\hat{g}'(0+) = \lim_{t \downarrow 0} \hat{g}'(t) = 0$ .

(iv)  $\hat{g}(0+) = \lim_{t \downarrow 0} \hat{g}(t) = \frac{\sigma_2}{\sigma_1 + \sigma_2}$ .

**Remark 4.8.**

(i) We choose the constant  $\frac{\sigma_2}{\sigma_1 + \sigma_2}$  in the definition (4.4) because

$$\lim_{\lambda \rightarrow \infty} \lambda F(\lambda) = \frac{\sigma_2}{\sigma_1 + \sigma_2}.$$

Moreover, it holds  $g(0+) = \lim_{\lambda \rightarrow \infty} \lambda F(\lambda)$  if the limit  $\hat{g}(0+)$  exists (see Theorem 33.5 in [4]).

(ii)  $\hat{g}(0+) = \frac{\sigma_2}{\sigma_1 + \sigma_2}$  implies that  $\lim_{t \downarrow 0} P(X_t^{l, \hat{a}} \in [l, u]) = \frac{\sigma_2}{\sigma_1 + \sigma_2}$ . Moreover, the function  $\hat{g}$  can be continuously extended to a function  $\hat{g} \in \mathcal{C}([0, \infty))$  by setting  $\hat{g}(0) := \frac{\sigma_2}{\sigma_1 + \sigma_2}$ . The derivative  $\hat{g}'$  can also be extended to  $\hat{g}' \in \mathcal{C}([0, \infty))$  by setting  $\hat{g}'(0) := 0$ .

(iii) We can rewrite the term in the integrand of (4.6) and (4.7) as follows:

$$\begin{aligned} \frac{1}{\frac{\sigma_1}{\sigma_2} \cot\left(\frac{u-l}{2\sigma_1}\sqrt{2s}\right) + \frac{\sigma_2}{\sigma_1} \tan\left(\frac{u-l}{2\sigma_1}\sqrt{2s}\right)} &= \frac{\frac{1}{2} \sin\left(\frac{u-l}{\sigma_1}\sqrt{2s}\right)}{\frac{\sigma_1}{\sigma_2} \cos^2\left(\frac{u-l}{2\sigma_1}\sqrt{2s}\right) + \frac{\sigma_2}{\sigma_1} \sin^2\left(\frac{u-l}{2\sigma_1}\sqrt{2s}\right)} \\ &= \frac{\frac{1}{2} \sin\left(\frac{u-l}{\sigma_1}\sqrt{2s}\right)}{\frac{\sigma_1}{\sigma_2} + \frac{\sigma_2 - \sigma_1^2}{\sigma_1 \sigma_2} \sin^2\left(\frac{u-l}{2\sigma_1}\sqrt{2s}\right)}, \quad s \in (0, \infty). \end{aligned}$$

Hence,  $\hat{g}$  is well-defined because for all  $t > 0$

$$\begin{aligned} &\int_0^\infty \frac{e^{-st}}{s} \left| \frac{1}{\frac{\sigma_1}{\sigma_2} \cot\left(\frac{u-l}{\sqrt{2\sigma_1}}\sqrt{s}\right) + \frac{\sigma_2}{\sigma_1} \tan\left(\frac{u-l}{\sqrt{2\sigma_1}}\sqrt{s}\right)} \right| ds \\ &\leq \frac{\sigma_2}{\sigma_1} \int_0^{s^*} \frac{1}{s} \sin\left(\frac{u-l}{\sigma_1}\sqrt{2s}\right) ds + \frac{\sigma_2}{\sigma_1} \frac{1}{s^*} \int_{s^*}^\infty e^{-st} ds < \infty, \end{aligned}$$

with  $s^* := \frac{\pi^2}{2} \frac{\sigma_1^2}{(u-l)^2}$ . Similarly, the integral on the right-hand side of (4.7) exists.

*Proof of Proposition 4.7.* Note that  $\hat{g} \in \mathcal{C}^1((0, \infty))$  follows directly from the representation in (4.6) because the integrand in (4.6) is differentiable and its derivative is dominated by integrable functions (see Remark 4.8 (iii)). Then, the Equation (4.7) follows from interchanging differentiation and integration.

Moreover, according to Lemma 4.5, there exists a continuous function  $\gamma$  given by (4.5) such that  $\mathcal{L}[\gamma] = \Gamma$ , or equivalently,  $\gamma = \mathcal{L}^{-1}[\Gamma]$ . We want to show that  $\hat{g}' = \gamma$ . Using properties of the Laplace inversion, in particular, [4], Theorem 27.1, and Lemma 4.4 (iii), we obtain the following formula for the primitive of  $\gamma$ : for  $b > 0$ , it holds

$$\begin{aligned} \int_0^t \gamma(s) ds &= \lim_{r \rightarrow \infty} \frac{1}{2\pi} \int_{-r}^r e^{(b+is)t} \frac{\Gamma(b+is)}{b+is} ds \\ &= \lim_{r \rightarrow \infty} \frac{1}{2\pi} \int_{-r}^r e^{(b+is)t} F(b+is) ds - \lim_{r \rightarrow \infty} \frac{1}{2\pi} \int_{-r}^r e^{(b+is)t} \frac{\sigma_2}{\sigma_1 + \sigma_2} \frac{1}{b+is} ds \\ &= \hat{g}(t) - \frac{\sigma_2}{\sigma_1 + \sigma_2}, \quad t > 0. \end{aligned}$$

Here we use that  $\mathcal{L}[\frac{\sigma_2}{\sigma_1 + \sigma_2}](\lambda) = \frac{\sigma_2}{\sigma_1 + \sigma_2} \frac{1}{\lambda}$ ,  $\lambda > 0$ , and [4], Theorem 24.4, to determine the second integral in the second line. Hence,

$$\hat{g}(t) = \frac{\sigma_2}{\sigma_1 + \sigma_2} + \int_0^t \gamma(s) ds, \quad t > 0.$$

We observe that  $\hat{g}(0+) = \frac{\sigma_2}{\sigma_1 + \sigma_2}$  and  $\hat{g}' = \gamma$  because both functions are continuous. Lemma 4.5 (iii) implies that  $\mathcal{L}[\hat{g}'] = \Gamma$ . The Laplace transform  $\mathcal{L}[\hat{g}](\lambda)$  is defined for all  $\lambda > 0$  because  $\mathcal{L}[\hat{g}'](\lambda)$  exists for all  $\lambda > 0$ . Moreover,

$$\mathcal{L}[\hat{g}](\lambda) = \frac{1}{\lambda} \mathcal{L}[\hat{g}'](\lambda) + \frac{\sigma_2}{\sigma_1 + \sigma_2} \frac{1}{\lambda} = \frac{1}{\lambda} \Gamma(\lambda) + \frac{\sigma_2}{\sigma_1 + \sigma_2} \frac{1}{\lambda} = F(\lambda), \quad \lambda > 0,$$

(see [4], Theorem 8.1). Finally, we conclude that  $g = \hat{g}$  a.e. because both functions have the same Laplace transform (see [4], Theorem 5.4).  $\square$

Proposition 4.7 only yields a formula for  $g$  in almost all  $t > 0$  because functions with the same Laplace transform only coincide up to null sets. For simplicity, we work with the version  $\hat{g}$  of  $g$  equal to the right-hand side of (4.6) because we do not know beforehand that  $g$  is continuous. The version  $\hat{g}$  is even continuously differentiable.

Moreover, recall that Lemma 4.2 provides a formula for  $Q$  on  $(0, \infty) \times \mathbb{R} \setminus \{l, u\}$  using the function  $g$ . Therefore, we define a version  $\hat{Q}$  of  $Q$  on  $(0, \infty) \times \mathbb{R}$  using  $\hat{g}$ . With the version  $\hat{Q}$ , we can define a candidate for the value function of our original control problem (2.1) and verify that it indeed coincides with the value function in the proof of Proposition 2.1. For  $(t, x) \in (0, \infty) \times \mathbb{R}$ , we define the function  $\hat{Q}$  by

$$\hat{Q}(t, x) := \begin{cases} \frac{l-x}{\sqrt{2\pi}\sigma_2} \int_0^t \hat{g}(t-s) s^{-\frac{3}{2}} \exp\left(-\frac{(x-l)^2}{2\sigma_2^2 s}\right) ds, & x < l, \\ 1 + \int_0^t (\hat{g}(t-s) - 1) h(s, x) ds, & x \in (l, u), \\ \frac{x-u}{\sqrt{2\pi}\sigma_2} \int_0^t \hat{g}(t-s) s^{-\frac{3}{2}} \exp\left(-\frac{(x-u)^2}{2\sigma_2^2 s}\right) ds, & x > u, \\ \hat{g}(t), & x \in \{l, u\}, \end{cases} \quad (4.8)$$

and we set  $\hat{Q}(0, x) := \mathbf{1}_{[l, u]}(x)$ . Note that  $\hat{Q} = Q$  on  $\mathbb{R}_+ \times \mathbb{R} \setminus \{l, u\}$ , and  $\hat{Q}(t, x) = Q(t, x)$  for almost every  $t \in \mathbb{R}_+$  if  $x \in \{l, u\}$ . Moreover,  $\mathcal{L}[\hat{Q}] = V$  because of Corollary 4.1.

**Lemma 4.9.** *The function  $\hat{Q}$  has the following properties:*

- (i)  $\hat{Q} \in \mathcal{C}^{1,2}((0, \infty) \times \mathbb{R} \setminus \{l, u\}) \cap \mathcal{C}^{0,1}((0, \infty) \times \mathbb{R})$ .
- (ii)  $\hat{Q}(t, \cdot)$  is symmetric in  $x = \frac{u+l}{2}$ .

The proof is postponed to Section A. To prove the assertions above, one has to argue why one can differentiate the integrals in (4.8). To this end, one employs, e.g., Leibniz's integral rule and the uniform convergence of the series in (4.2).

We now turn to the proof of the Proposition 2.1. Recall the HJB equation of the control problem (2.1) given by Equation (2.6).

*Proof of Proposition 2.1. Step 1.* Let  $w(t, x) := \int_0^t \hat{Q}(s, x) ds$  for  $(t, x) \in \mathbb{R}_+ \times \mathbb{R}$ . The definition implies that  $w \in \mathcal{C}^{1,2}((0, \infty) \times \mathbb{R} \setminus \{l, u\}) \cap \mathcal{C}^{1,1}((0, \infty) \times \mathbb{R})$ . We show that  $w$  solves the HJB equation (2.6). Because  $\mathcal{L}[\hat{Q}(\cdot, x)]$  exists on  $(0, \infty)$ , we know by [4], Theorem 8.1, that also the Laplace transform of  $w$  exists and

$$\mathcal{L}[w(\cdot, x)](\lambda) = \frac{1}{\lambda} \mathcal{L}[\hat{Q}(\cdot, x)](\lambda), \quad \lambda > 0. \quad (4.9)$$

Moreover,  $\mathcal{L}[\hat{Q}(\cdot, x)](\lambda) = V(x, \lambda)$ , and  $V$  satisfies (3.3), (3.4), and (3.5). Therefore, by multiplying (3.4) and (3.5) with  $\frac{1}{\lambda}$ , we see that the Laplace transform of  $w$  solves the equations

$$\begin{aligned} \lambda \mathcal{L}[w(\cdot, x)](\lambda) - \frac{1}{\lambda} - \frac{\sigma_1^2}{2} \partial_{xx} \mathcal{L}[w(\cdot, x)](\lambda) &= 0, \quad x \in (l, u), \\ \lambda \mathcal{L}[w(\cdot, x)](\lambda) - \frac{\sigma_2^2}{2} \partial_{xx} \mathcal{L}[w(\cdot, x)](\lambda) &= 0, \quad x \notin [l, u]. \end{aligned}$$

Observe that  $\mathcal{L}[\partial_t w(\cdot, x)](\lambda) = \lambda \mathcal{L}[w(\cdot, x)](\lambda)$  and  $\mathcal{L}[\partial_{xx} w(\cdot, x)](\lambda) = \partial_{xx} \mathcal{L}[w(\cdot, x)](\lambda)$  for all  $\lambda > 0$ . Consequently, the injectivity and linearity of the Laplace transform imply that  $w$  satisfies the equations

$$\begin{aligned} \partial_t w(t, x) - 1 - \frac{\sigma_1^2}{2} \partial_{xx} w(t, x) &= 0, \quad x \in (l, u), \\ \partial_t w(t, x) - \frac{\sigma_2^2}{2} \partial_{xx} w(t, x) &= 0, \quad x \notin [l, u], \end{aligned} \quad (4.10)$$

for all  $x \in \mathbb{R}$  and almost all  $t \in (0, \infty)$ . The continuity of  $\partial_t w$  and  $\partial_{xx} w$  in  $t$  implies that (4.10) holds for all  $t > 0$ .

Now, we observe that  $\partial_t w(t, x) = \hat{Q}(t, x) \in [0, 1]$  for all  $(t, x) \in (0, \infty) \times \mathbb{R}$ . Hence, (4.10) implies that  $w(t, \cdot)$  is concave on  $[l, u]$  and convex on  $\mathbb{R} \setminus [l, u]$  for all  $t > 0$ . As a direct consequence,  $w$  solves the HJB equation (2.6).

*Step 2.* We show that  $w = v$ . The definition of  $w$  implies that

$$w(t, x) = \int_0^t P(X_s^{x, \hat{\alpha}} \in [l, u]) ds = J(t, x, \hat{\alpha}) \leq v(t, x), \quad (t, x) \in \mathbb{R}_+ \times \mathbb{R},$$

where  $X^{x, \hat{\alpha}}$  is the solution of the SDE (2.2) controlled by the feedback control  $\hat{\alpha}_s = \hat{a}(X_s^{x, \hat{\alpha}})$  and starting at time 0 in  $x$ . Hence, it suffices to show that  $w(t, x) \geq v(t, x)$ . Let  $(t, x) \in (0, \infty) \times \mathbb{R}$  and  $\alpha \in \mathcal{A}$  be an arbitrary control. We denote by  $X^{x, \alpha}$  the process governed by Equation

(1.1) and controlled by  $\alpha$ . We apply Itô's formula to  $(s, x) \mapsto w(t - s, x)$  between 0 and  $t$ , and conclude after taking expectations (and localizing the terms) that

$$0 = w(t, x) + E \left[ \int_0^t \left( -\partial_t w(t - s, X_s^{x, \alpha}) + \frac{\alpha_s^2}{2} \partial_{xx} w(t - s, X_s^{x, \alpha}) \right) ds \right]. \quad (4.11)$$

Itô's formula holds because  $w \in \mathcal{C}^{1,2}((0, \infty) \times \mathbb{R} \setminus \{l, u\}) \cap \mathcal{C}^{1,1}((0, \infty) \times \mathbb{R})$  and  $\partial_x w(t, \cdot)$  is absolutely continuous for all  $t > 0$  (see, e.g., [1] or [6], Section 3.7). Because  $w$  solves the HJB equation (2.6),  $w(t, \cdot)$  is concave on  $[l, u]$  and convex otherwise, we can estimate the integrand on the right-hand side of (4.11) from above by  $-\mathbf{1}_{[l, u]}(X_s^{x, \alpha})$ . It follows that

$$0 \leq w(t, x) - \int_0^t P(X_s^{x, \alpha} \in [l, u]) ds.$$

The choice of  $\alpha$  is arbitrary and hence, it follows that  $v(t, x) \leq w(t, x)$ . Finally,  $w = v$  and  $\hat{\alpha}$  is an optimal control. We conclude that  $\mathcal{L}[v(\lambda, x)] = \mathcal{L}[w(\lambda, x)] = \frac{1}{\lambda} V(x, \lambda) = \frac{1}{\lambda} G(x, \lambda)$  by Equation (4.9) and Proposition 3.2. Then, Equation (2.5) follows from Equation (3.6).

*Step 3.* Step 2 implies that  $v(t, x) = \int_0^t \hat{Q}(s, x) ds$ . The definition of  $\hat{Q}$  in (4.8) yields the representation of  $v$  in (2.4): for  $x \in (l, u)$  and  $t > 0$

$$v(t, x) = \int_0^t \left( 1 + \int_0^s (\hat{g}(s - r) - 1) h(r, x) dr \right) ds = t + \int_0^t \int_0^s (\hat{g}(s - r) - 1) h(r, x) dr ds,$$

by using Remark 4.2. The case  $x \notin (l, u)$  follows similarly. □

## 5 Proof of Corollary 1.3

Before proving Corollary 1.3, we state the following auxiliary result.

**Lemma 5.1.** *Let the assumptions of Corollary 1.3 hold. Then*

$$P(X_\tau \in [l, u]) \leq \frac{\sigma_2}{\sigma_1^2} \sqrt{\frac{\lambda}{2}} e^{\frac{\sqrt{2\lambda}}{\sigma_1}(u-l)} (u-l).$$

*Proof.* For  $x \notin [l, u]$  we have, using the independence of  $X$  and  $\tau$ , as well as Theorem 1.2,

$$\begin{aligned} P(X_\tau \in [l, u]) &= \int_0^\infty \lambda e^{-\lambda t} P(X_t \in [l, u]) dt \\ &\leq \frac{1}{\frac{\sigma_1}{\sigma_2} \coth\left(\frac{u-l}{2\sigma_1} \sqrt{2\lambda}\right) + 1} \exp\left(-\frac{\sqrt{2\lambda}}{\sigma_2} d(x, I)\right) \\ &\leq \frac{1}{\frac{\sigma_1}{\sigma_2} \coth\left(\frac{u-l}{2\sigma_1} \sqrt{2\lambda}\right) + 1} \\ &= \frac{\sigma_2}{\sigma_1} \frac{1}{2 + \frac{2}{\exp\left(\frac{u-l}{\sigma_1} \sqrt{2\lambda}\right) - 1}} \\ &= \frac{\sigma_2}{2\sigma_1} \frac{\exp\left(\frac{u-l}{\sigma_1} \sqrt{2\lambda}\right) - 1}{\exp\left(\frac{u-l}{\sigma_1} \sqrt{2\lambda}\right)} \\ &\leq \frac{\sigma_2}{2\sigma_1} \left(e^{\frac{\sqrt{2\lambda}}{\sigma_1}(u-l)} - 1\right) \\ &\leq \frac{\sigma_2}{\sigma_1^2} \sqrt{\frac{\lambda}{2}} e^{\frac{\sqrt{2\lambda}}{\sigma_1}(u-l)} (u-l), \end{aligned}$$

with the identities  $\coth(y) = 1 + \frac{2}{e^{2y} - 1}$  and  $e^y - 1 \leq ye^y$ ,  $y \geq 0$ . For  $x \in [l, u]$ , we have, using the same arguments as above,

$$\begin{aligned} P(X_\tau \in [l, u]) &= \int_0^\infty \lambda e^{-\lambda t} P(X_t \in [l, u]) dt \\ &\leq 1 - \frac{\cosh\left(\frac{2x-(u+l)}{2\sigma_1} \sqrt{2\lambda}\right)}{\cosh\left(\frac{u-l}{2\sigma_1} \sqrt{2\lambda}\right) + \frac{\sigma_2}{\sigma_1} \sinh\left(\frac{u-l}{2\sigma_1} \sqrt{2\lambda}\right)} \\ &\leq 1 - \frac{1}{\cosh\left(\frac{u-l}{2\sigma_1} \sqrt{2\lambda}\right) + \frac{\sigma_2}{\sigma_1} \sinh\left(\frac{u-l}{2\sigma_1} \sqrt{2\lambda}\right)} \\ &= \frac{\cosh\left(\frac{u-l}{2\sigma_1} \sqrt{2\lambda}\right) + \frac{\sigma_2}{\sigma_1} \sinh\left(\frac{u-l}{2\sigma_1} \sqrt{2\lambda}\right) - 1}{\cosh\left(\frac{u-l}{2\sigma_1} \sqrt{2\lambda}\right) + \frac{\sigma_2}{\sigma_1} \sinh\left(\frac{u-l}{2\sigma_1} \sqrt{2\lambda}\right)} \\ &\leq \cosh\left(\frac{u-l}{2\sigma_1} \sqrt{2\lambda}\right) + \frac{\sigma_2}{\sigma_1} \sinh\left(\frac{u-l}{2\sigma_1} \sqrt{2\lambda}\right) - 1 \\ &\leq \frac{\sigma_2}{\sigma_1} \left(\cosh\left(\frac{u-l}{2\sigma_1} \sqrt{2\lambda}\right) + \sinh\left(\frac{u-l}{2\sigma_1} \sqrt{2\lambda}\right) - 1\right) \\ &= \frac{\sigma_2}{\sigma_1} \left(e^{\frac{\sqrt{2\lambda}}{2\sigma_1}(u-l)} - 1\right) \leq \frac{\sigma_2}{\sigma_1^2} \sqrt{\frac{\lambda}{2}} e^{\frac{\sqrt{2\lambda}}{\sigma_1}(u-l)} (u-l). \end{aligned}$$

□



*Proof of Corollary 1.3.* Let  $N \subseteq \mathbb{R}$  be a Lebesgue null set and  $\varepsilon > 0$ . Then,  $N$  can be covered by a countable union of intervals  $[l_n, u_n]$ ,  $n \in \mathbb{N}$ , such that  $\sum_{n=1}^{\infty} |u_n - l_n| < \varepsilon$ . We have, using Lemma 5.1,

$$\begin{aligned} P(X_\tau \in N) &\leq \sum_{n=1}^{\infty} P(X_\tau \in [l_n, u_n]) \\ &\leq \sum_{n=1}^{\infty} \frac{\sigma_2}{\sigma_1^2} \sqrt{\frac{\lambda}{2}} e^{\frac{\sqrt{2\lambda}}{\sigma_1}(u_n - l_n)} (u_n - l_n) \\ &\leq \frac{\sigma_2}{\sigma_1^2} \sqrt{\frac{\lambda}{2}} e^{\frac{\sqrt{2\lambda}}{\sigma_1}\varepsilon} \sum_{n=1}^{\infty} (u_n - l_n) < \frac{\sigma_2}{\sigma_1^2} \sqrt{\frac{\lambda}{2}} e^{\frac{\sqrt{2\lambda}}{\sigma_1}\varepsilon} \varepsilon. \end{aligned}$$

Because the choice of  $\varepsilon > 0$  is arbitrary, we conclude that  $P(X_\tau^{x,\beta} \in N) = 0$ , and hence,  $X_\tau$  is absolutely continuous.  $\square$

## 6 Expected occupation time for half-open intervals

This section studies the cases  $u = \infty$  and  $l = -\infty$ , i.e., we determine upper bounds for the expected occupation time in half-open intervals. It suffices to consider the case  $u = \infty$  because of symmetry. The control problem reformulates to

$$v(t, x) = \sup_{\alpha \in \mathcal{A}} \int_0^t P(X_s^{x,\alpha} \geq l) ds, \quad (6.1)$$

and the HJB equation is given by

$$\begin{aligned} \partial_t v(t, x) - \mathbf{1}_{[l, \infty)}(x) - \sup_{b \in [\sigma_1, \sigma_2]} \frac{b^2}{2} \partial_{xx} v(t, x) &= 0, \quad (t, x) \in (0, \infty) \times \mathbb{R}, \\ v(0, x) &= 0, \quad x \in \mathbb{R}. \end{aligned} \quad (6.2)$$

As in the previous sections, we consider in the beginning the infinite time horizon problem

$$V(x) = \sup_{\alpha \in \mathcal{A}} \int_0^\infty e^{-\lambda t} P(X_t^{x,\alpha} \geq l) dt,$$

to derive a solution to the original problem (6.1). For the infinite time horizon control problem, the HJB equation is given by

$$\lambda V(x) - \mathbf{1}_{[l, \infty)}(x) - \sup_{b \in [\sigma_1, \sigma_2]} \frac{b^2}{2} V''(x) = 0, \quad x \in \mathbb{R}.$$

One can solve the control problem by verifying that the function given by the limit of (3.6) as  $u \rightarrow \infty$  coincides with the value function. Alternatively, one can solve the HJB equation as in Section 3 by assuming that  $V$  is convex on  $(-\infty, l)$  and concave otherwise, and verify that the solution coincides with the value function. In both cases, we deduce that

$$V(x) = \begin{cases} \frac{\sigma_2}{\sigma_1 + \sigma_2} \frac{1}{\lambda} e^{\frac{\sqrt{2\lambda}}{\sigma_2}(x-l)}, & x < l, \\ \frac{1}{\lambda} - \frac{1}{\lambda} \frac{\sigma_1}{\sigma_1 + \sigma_2} e^{-\frac{\sqrt{2\lambda}}{\sigma_1}(x-l)}, & x \geq l. \end{cases}$$

Moreover, the optimal control is given by the feedback function

$$b(x) := \sigma_1 \mathbf{1}_{[l, \infty)}(x) + \sigma_2 \mathbf{1}_{(-\infty, l)}(x), \quad x \in \mathbb{R}.$$

Now, to solve our original problem (6.1), we observe that the inverse Laplace transform of  $V$  is given by

$$\hat{Q}(t, x) := \mathcal{L}^{-1}[V(x)](t) = \begin{cases} \frac{2\sigma_2}{\sigma_1 + \sigma_2} \Phi\left(\frac{x-l}{\sigma_2\sqrt{t}}\right), & x < l, \\ 1 - \frac{2\sigma_1}{\sigma_1 + \sigma_2} \Phi\left(\frac{l-x}{\sigma_1\sqrt{t}}\right), & x \geq l. \end{cases}$$

We see that  $w$ , given by  $w(t, x) := \int_0^t \hat{Q}(s, x) ds$ , solves the HJB equation (6.2) by standard results for Laplace transforms. Then, it is straightforward to show that  $v = w$  and the optimal control is given by the feedback function  $b$ .

We remark that the solution in the unbounded case can also be derived from [9], Remark 8.

## A Auxiliary results

### Proof of Lemma 4.4

*Proof of Lemma 4.4. Part (i).* Recall that for all  $x, y \in \mathbb{R}$

$$\sqrt{x + iy} = \sqrt{\frac{\sqrt{x^2 + y^2} + x}{2}} + i \cdot \operatorname{sgn}^+(y) \sqrt{\frac{\sqrt{x^2 + y^2} - x}{2}}, \quad (\text{A.1})$$

see Equation (4.3). We rewrite the complex hyperbolic cotangent function as follows:

$$\coth(x + iy) = \frac{\sinh(2x)}{\cosh(2x) - \cos(2y)} - i \frac{\sin(2y)}{\cosh(2x) - \cos(2y)}, \quad (\text{A.2})$$

for any  $x, y \in \mathbb{R}$  such that  $y \neq k\pi$ ,  $k \in \mathbb{Z}$ , if  $x = 0$ . Hence, for  $z \in \mathbb{C}$  and  $x + iy := \frac{u-l}{\sqrt{2}\sigma_1} \sqrt{z}$

$$\begin{aligned} & \left| \frac{\sigma_1}{\sigma_2} \coth\left(\frac{u-l}{\sqrt{2}\sigma_1} \sqrt{z}\right) + 1 \right|^2 \\ &= \left( 1 + \frac{\sigma_1}{\sigma_2} \frac{\sinh(2x)}{\cosh(2x) - \cos(2y)} \right)^2 + \left( -\frac{\sigma_1}{\sigma_2} \frac{\sin(2y)}{\cosh(2x) - \cos(2y)} \right)^2 \end{aligned} \quad (\text{A.3})$$

$$\geq 1 + \left( -\frac{\sigma_1}{\sigma_2} \frac{\sin(2y)}{\cosh(2x) - \cos(2y)} \right)^2 \geq 1, \quad (\text{A.4})$$

where we use that  $x = \frac{u-l}{\sqrt{2}\sigma_1} \operatorname{Re}(\sqrt{z}) > 0$ . We emphasize that the inequalities in (A.4) extend to the case where  $x = 0$  and  $y = k\pi$ ,  $k \in \mathbb{Z}$ , because  $\coth(x + iy)$  has a pole in those points. It follows that

$$|F(z)| = \frac{1}{|z|} \frac{1}{\left| \frac{\sigma_1}{\sigma_2} \coth\left(\frac{m-l}{\sigma_1} \sqrt{2z}\right) + 1 \right|} \leq \frac{1}{|z|}, \quad z \in \mathbb{C}. \quad (\text{A.5})$$

*Part (ii).* The complex square root  $\sqrt{\cdot}$  is holomorphic on  $D$ . Equation (A.1) implies that for all  $z \in D$ ,  $\operatorname{Re}(\sqrt{z}) > 0$ . Moreover, the complex hyperbolic cotangent function  $\coth$  is holomorphic on  $\mathbb{C} \setminus \{ik\pi : k \in \mathbb{Z}\}$ . Hence,  $F$  is holomorphic on  $D$  by the chain rule.

*Part (iii).* Let  $b > 0$ ,  $\varepsilon > 0$  sufficiently small, and  $r > \varepsilon$ . Fix  $t > 0$ . By Cauchy's theorem, we deduce that the integral over the contour shown in Figure 1 below is equal to zero, i.e.,

$$\int_{-r}^r F(b + is) e^{(b+is)t} ds = - \sum_{i=1}^7 \int_{\gamma_i(r, \varepsilon)} F(z) e^{zt} dz. \quad (\text{A.6})$$

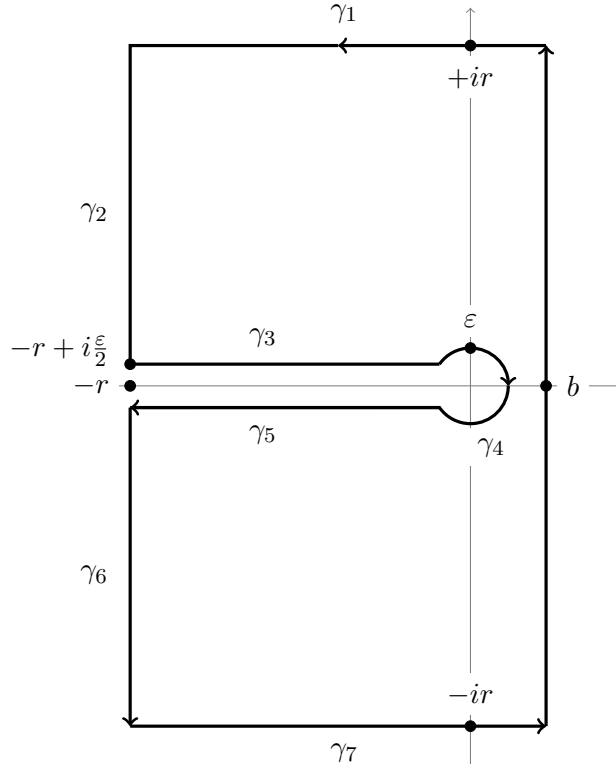

Figure 1: Contour for Cauchy's theorem

We want to consider the behavior of the integral in the limit as  $\varepsilon \rightarrow 0$  and  $r \rightarrow +\infty$ . We consider the line integrals separately.

*Step 1.* The line integrals along  $\gamma_1$  and  $\gamma_7$  do not depend on  $\varepsilon$  and converge to zero as  $r \rightarrow \infty$ : one can bound  $|F(z)|$  by  $\frac{1}{r}$  for  $z \in \text{Ran}(\gamma_i)$  because of (A.5). Here  $\text{Ran}(\gamma_i)$  denotes the range or image of  $\gamma_i$ . We have, e.g.,

$$\left| \int_{\gamma_1} F(z)e^{zt} dz \right| = \left| \int_0^{b+r} F(b-s+ir)e^{(b-s+ir)t} ds \right| \leq \frac{e^b}{r} \int_0^{b+r} e^{-st} ds = \frac{e^b}{rt} (1 - e^{-(b+r)t}) \rightarrow 0,$$

as  $r \rightarrow \infty$ . The line integral along  $\gamma_7$  can be estimated similarly. Hence,

$$\lim_{r \rightarrow \infty} \int_{\gamma_i} F(z)e^{zt} dz = 0, \quad i = 1, 7.$$

*Step 2.* The line integrals along  $\gamma_2$  and  $\gamma_6$  can be estimated as the integrals in Step 1. We see, e.g., that

$$\int_{\gamma_2(r,\varepsilon)} F(z)e^{zt} dz = - \int_0^{r-\frac{\varepsilon}{2}} F(-r+i(r-s))e^{(-r+i(r-s))t} ds.$$

The integral on the right-hand side also exists for  $\varepsilon = 0$ , and hence,

$$\lim_{\varepsilon \downarrow 0} \int_{\gamma_2(r,\varepsilon)} F(z)e^{zt} dz = - \int_0^r F(-r+i(r-s))e^{(-r+i(r-s))t} ds.$$

Finally, we conclude as in Step 1 that

$$\lim_{r \rightarrow \infty} \lim_{\varepsilon \downarrow 0} \int_{\gamma_2(r,\varepsilon)} F(z)e^{zt} dz = 0.$$

The arguments hold for  $\gamma_6$  as well, i.e.,

$$\lim_{r \rightarrow \infty} \lim_{\varepsilon \downarrow 0} \int_{\gamma_6(r, \varepsilon)} F(z) e^{zt} dz = 0.$$

*Step 3.* For the line integral along  $\gamma_4$ , we find that

$$\begin{aligned} \left| \int_{\gamma_4} F(z) e^{zt} dz \right| &\leq \left( \max_{z \in \text{Ran}(\gamma_4)} |F(z) e^{zt}| \right) L(\gamma_4) \leq 2\pi\varepsilon \max_{|z|=\varepsilon} \frac{|e^{zt}|}{|z|} \frac{1}{\left| \frac{\sigma_1}{\sigma_2} \coth \left( \frac{u-l}{\sqrt{2}\sigma_1} \sqrt{z} \right) + 1 \right|} \\ &\leq 2\pi e^{\varepsilon t} \max_{|z|=\varepsilon} \frac{1}{\left| \frac{\sigma_1}{\sigma_2} \coth \left( \frac{u-l}{\sqrt{2}\sigma_1} \sqrt{z} \right) + 1 \right|}, \end{aligned}$$

where  $L(\gamma_4)$  denotes the length of the curve  $\gamma_4$ . Using Equation (A.1), we see for  $z = x + iy \in \mathbb{C}$ ,  $|z| = \varepsilon$ , that

$$\sqrt{z} = \sqrt{\frac{\sqrt{x^2 + y^2} + x}{2}} + i \cdot \text{sgn}^+(y) \sqrt{\frac{\sqrt{x^2 + y^2} - x}{2}} = \frac{1}{\sqrt{2}} (\sqrt{\varepsilon + x} + i \cdot \text{sgn}^+(y) \sqrt{\varepsilon - x}),$$

and thus, with (A.3) and L'Hôpital's rule

$$\begin{aligned} \frac{1}{\left| \frac{\sigma_1}{\sigma_2} \coth \left( \frac{u-l}{\sqrt{2}\sigma_1} \sqrt{z} \right) + 1 \right|} &\leq \frac{\sigma_2}{\sigma_1} \frac{\cosh \left( \frac{u-l}{\sigma_1} \sqrt{\varepsilon + x} \right) - \cos \left( \frac{u-l}{\sigma_1} \sqrt{\varepsilon - x} \right)}{\sinh \left( \frac{u-l}{\sigma_1} \sqrt{\varepsilon + x} \right)} \\ &\leq \frac{\cosh \left( \frac{u-l}{\sigma_1} \sqrt{\varepsilon} \right) - \cos \left( \frac{u-l}{\sigma_1} \sqrt{\varepsilon} \right)}{\sinh \left( \frac{u-l}{\sigma_1} \sqrt{\varepsilon} \right)} \xrightarrow{\varepsilon \downarrow 0} 0. \end{aligned}$$

From the first to the second line, we use that the term is monotonically decreasing in  $x$ . To summarize, the line integral along  $\gamma_4$  converges to zero as  $\varepsilon \downarrow 0$ .

*Step 4.* We consider the line integrals along  $\gamma_3$  and  $\gamma_5$ : one can parametrize  $\gamma_3$ , e.g., by  $\gamma_3(s) = -s + i\frac{\varepsilon}{2}$  for  $s \in [\frac{\sqrt{3}}{2}\varepsilon, r]$ . Therefore,

$$\int_{\gamma_3} F(z) e^{zt} dz = - \int_{\frac{\sqrt{3}}{2}\varepsilon}^r F \left( -s + i\frac{\varepsilon}{2} \right) e^{(-s+i\frac{\varepsilon}{2})t} ds.$$

First, we want to take the limit  $\varepsilon \downarrow 0$ . We observe with  $C := \frac{u-l}{2\sigma_1}$ ,

$$x := C \sqrt{\sqrt{s^2 + \frac{\varepsilon^2}{4}} - s}, \quad y := C \sqrt{\sqrt{s^2 + \frac{\varepsilon^2}{4}} + s},$$

and Equation (A.2) that: for  $\varepsilon > 0$  sufficiently small and  $\frac{\sqrt{3}}{2}\varepsilon \leq s \leq s^* := \frac{\pi^2}{12C^2}$ , it holds  $0 \leq y \leq \frac{\pi}{2}$  and

$$\begin{aligned} \left| \coth \left( \frac{u-l}{\sqrt{2}\sigma_1} \sqrt{-s + i\frac{\varepsilon}{2}} \right) + \frac{\sigma_2}{\sigma_1} \right|^2 &= \left| \coth(x + iy) + \frac{\sigma_2}{\sigma_1} \right|^2 \\ &= \left( \frac{\sigma_2}{\sigma_1} + \frac{\sinh(2x)}{\cosh(2x) - \cos(2y)} \right)^2 + \left( \frac{\sin(2y)}{\cosh(2x) - \cos(2y)} \right)^2 \\ &\geq \left( \frac{\sigma_2}{\sigma_1} \right)^2 + \left( \frac{\sin(2y)}{1 - \cos(2y)} \right)^2 \end{aligned}$$

$$\begin{aligned}
&\geq 1 + \left( \frac{\sin(2y)}{1 - \cos(2y)} \right)^2 \\
&= 1 + \cot^2(y) = \frac{1}{\sin^2(y)} = \frac{1}{\sin^2 \left( C\sqrt{\sqrt{s^2 + \frac{\varepsilon^2}{4}} + s} \right)}.
\end{aligned}$$

Hence,

$$\left| F \left( -s + i\frac{\varepsilon}{2} \right) \right| \leq \frac{1}{s} \left| \sin \left( C\sqrt{\sqrt{s^2 + \frac{\varepsilon^2}{4}} + s} \right) \right| \leq \frac{\sin \left( C\sqrt{2s + \frac{\varepsilon}{2}} \right)}{s} \leq \frac{\sin \left( C\sqrt{3s} \right)}{s},$$

because  $\sin(C\sqrt{\cdot})$  is increasing and positive on  $[0, \frac{\pi^2}{4C^2}]$ . The function  $s \mapsto \frac{1}{s} \sin(C\sqrt{3s})$  is integrable on  $[0, s^*]$ . Therefore,

$$\left| F \left( -s + i\frac{\varepsilon}{2} \right) e^{(-s+i\frac{\varepsilon}{2})t} \right| \leq \frac{1}{s} \sin \left( C\sqrt{3s} \right) \mathbf{1}_{[0, s^*]}(s) + \frac{1}{s} e^{-st} \mathbf{1}_{[s^*, r]}(s),$$

with integrable right-hand side. Dominated convergence yields

$$\lim_{\varepsilon \downarrow 0} \int_{\gamma_3(r, \varepsilon)} F(z) e^{zt} dz = \lim_{\varepsilon \downarrow 0} \int_{\frac{\sqrt{3}}{2}\varepsilon}^r F \left( -s + i\frac{\varepsilon}{2} \right) e^{(-s+i\frac{\varepsilon}{2})t} ds = \int_0^r F(-s) e^{-st} ds.$$

In particular, the integral on the right-hand side exists. Now, we consider the limit  $r \rightarrow \infty$ : because  $|F(-s)| \leq 1$  for  $s \geq 1$  according to (A.5), the integral  $\int_1^\infty F(-s) e^{-st} ds$  exists. Consequently, also the integral  $\int_0^\infty F(-s) e^{-st} ds$  exists and

$$\begin{aligned}
\lim_{r \rightarrow \infty} \lim_{\varepsilon \downarrow 0} \int_{\gamma_3(r, \varepsilon)} F(z) e^{zt} dz &= \int_0^\infty F(-s) e^{-st} ds \\
&= - \int_0^\infty e^{-st} \frac{1}{s \frac{\sigma_1}{\sigma_2} \coth \left( i \frac{u-l}{\sqrt{2}\sigma_1} \sqrt{s} \right) + 1} ds \\
&= - \int_0^\infty e^{-st} \frac{1}{s - i \frac{\sigma_1}{\sigma_2} \cot \left( \frac{u-l}{\sqrt{2}\sigma_1} \sqrt{s} \right) + 1} ds.
\end{aligned}$$

In the same way, one can show that the line integral along  $\gamma_5$  converges. We find that

$$\begin{aligned}
\lim_{r \rightarrow \infty} \lim_{\varepsilon \downarrow 0} \int_{\gamma_5(r, \varepsilon)} F(z) e^{zt} dz &= \lim_{r \rightarrow \infty} \lim_{\varepsilon \downarrow 0} \int_{\frac{\sqrt{3}}{2}\varepsilon}^r F \left( -s - i\frac{\varepsilon}{2} \right) e^{(-s-i\frac{\varepsilon}{2})t} ds \\
&= \int_0^\infty \frac{e^{-st}}{s \frac{\sigma_1}{\sigma_2} \coth \left( \frac{u-l}{\sqrt{2}\sigma_1} (-i) \sqrt{s} \right) + 1} ds \\
&= \int_0^\infty \frac{e^{-st}}{s i \frac{\sigma_1}{\sigma_2} \cot \left( \frac{u-l}{\sqrt{2}\sigma_1} \sqrt{s} \right) + 1} ds.
\end{aligned}$$

*Step 5.* The results above show that the right-hand side of Equation (A.6) converges as  $r \rightarrow +\infty$ . Hence, also the limit of the left-hand side of Equation (A.6) exists and we see that

$$\begin{aligned}
& \lim_{r \rightarrow \infty} \int_{-r}^r F(b+is)e^{(b+is)t} ds \\
&= \int_0^\infty e^{-st} \frac{1}{s - i \frac{\sigma_1}{\sigma_2} \cot\left(\frac{u-l}{\sqrt{2}\sigma_1} \sqrt{s}\right) + 1} ds - \int_0^\infty \frac{e^{-st}}{s} \frac{1}{i \frac{\sigma_1}{\sigma_2} \cot\left(\frac{u-l}{\sqrt{2}\sigma_1} \sqrt{s}\right) + 1} ds \\
&= \int_0^\infty \frac{e^{-st}}{s} \left( \frac{1}{-i \frac{\sigma_1}{\sigma_2} \cot\left(\frac{u-l}{\sqrt{2}\sigma_1} \sqrt{s}\right) + 1} - \frac{1}{i \frac{\sigma_1}{\sigma_2} \cot\left(\frac{u-l}{\sqrt{2}\sigma_1} \sqrt{s}\right) + 1} \right) ds \\
&= \int_0^\infty \frac{e^{-st}}{s} \frac{2i \frac{\sigma_1}{\sigma_2} \cot\left(\frac{u-l}{\sqrt{2}\sigma_1} \sqrt{s}\right)}{\left(\frac{\sigma_1}{\sigma_2} \cot\left(\frac{u-l}{\sqrt{2}\sigma_1} \sqrt{s}\right)\right)^2 - 1} ds \\
&= 2i \int_0^\infty \frac{e^{-st}}{s} \frac{1}{\frac{\sigma_1}{\sigma_2} \cot\left(\frac{u-l}{\sqrt{2}\sigma_1} \sqrt{s}\right) + \frac{\sigma_2}{\sigma_1} \tan\left(\frac{u-l}{\sqrt{2}\sigma_1} \sqrt{s}\right)} ds, \quad t > 0.
\end{aligned}$$

Now, we consider the limit  $b \downarrow 0$ : using the arguments above, we find for the limit  $\varepsilon \downarrow 0$  in (A.6) that

$$\begin{aligned}
\int_{-r}^r F(b+is)e^{(b+is)t} ds &= \int_0^{b+r} F(b-s+ir)e^{(b-s+ir)t} ds - \int_0^{b+r} F(s-r-ir)e^{(s-r-ir)t} ds \\
&\quad + \int_0^r F(-r+i(r-s))e^{(-r+i(r-s))t} ds + \int_0^r F(-r-is)e^{(-r-is)t} ds \\
&\quad + 2i \int_0^r \frac{e^{-st}}{s} \frac{1}{\frac{\sigma_1}{\sigma_2} \cot\left(\frac{u-l}{\sqrt{2}\sigma_1} \sqrt{s}\right) + \frac{\sigma_2}{\sigma_1} \tan\left(\frac{u-l}{\sqrt{2}\sigma_1} \sqrt{s}\right)} ds.
\end{aligned}$$

The integrals on the right-hand side are derived (in the order of appearance) from the curves  $\gamma_1$ ,  $\gamma_7$ ,  $\gamma_2$ ,  $\gamma_6$ , and the last one from both  $\gamma_3$  and  $\gamma_5$ . The line integral along  $\gamma_4$  vanishes as  $\varepsilon \rightarrow 0$ . We use dominated convergence on both sides for the limit  $b \downarrow 0$  (similar to Step 4) and see that

$$\begin{aligned}
\int_{-r}^r F(is)e^{ist} ds &= \int_0^r F(-s+ir)e^{(-s+ir)t} ds - \int_0^r F(s-r-ir)e^{(s-r-ir)t} ds \\
&\quad + \int_0^r F(-r+i(r-s))e^{(-r+i(r-s))t} ds + \int_0^r F(-r-is)e^{(-r-is)t} ds \\
&\quad + 2i \int_0^r \frac{e^{-st}}{s} \frac{1}{\frac{\sigma_1}{\sigma_2} \cot\left(\frac{u-l}{\sqrt{2}\sigma_1} \sqrt{s}\right) + \frac{\sigma_2}{\sigma_1} \tan\left(\frac{u-l}{\sqrt{2}\sigma_1} \sqrt{s}\right)} ds.
\end{aligned}$$

The first four integrals vanish in the limit  $r \rightarrow \infty$ . We conclude for  $r \rightarrow \infty$  that

$$\lim_{r \rightarrow \infty} \int_{-r}^r F(is)e^{ist} ds = 2i \int_0^\infty \frac{e^{-st}}{s} \frac{1}{\frac{\sigma_1}{\sigma_2} \cot\left(\frac{u-l}{\sqrt{2}\sigma_1} \sqrt{s}\right) + \frac{\sigma_2}{\sigma_1} \tan\left(\frac{u-l}{\sqrt{2}\sigma_1} \sqrt{s}\right)} ds.$$

The limit exists because the convergence of the right-hand side can be shown similar to Steps 1-4.  $\square$

## Proof of Lemma 4.5

*Proof of Lemma 4.5. Part (i).* The result follows from Lemma 4.4 (ii) by the product rule.

*Part (ii).* Let  $x > 0$  and  $y \in \mathbb{R}$  be fixed for the following estimates. We want to estimate  $|\Gamma(x + iy)|$  to show the absolute integrability of  $\Gamma(x + i \cdot)$ . We denote by  $r$  and  $s$  the real and imaginary part of  $\sqrt{2}(u-l)\sigma_1^{-1}\sqrt{x+iy}$ , i.e.,  $r + is := \sqrt{2}(u-l)\sigma_1^{-1}\sqrt{x+iy}$ . In particular,

$$r = \frac{u-l}{\sigma_1} \sqrt{\sqrt{x^2+y^2}+x} > 0, \quad s = \operatorname{sgn}^+(y) \frac{u-l}{\sigma_1} \sqrt{\sqrt{x^2+y^2}-x},$$

(recall Equation (A.1)). Using the representation (A.2) of the complex hyperbolic cotangent, we have

$$\left| \frac{\sigma_1}{\sigma_2} \coth \left( \frac{u-l}{\sqrt{2}\sigma_1} \sqrt{x+iy} \right) + 1 \right| = \left| \frac{\sigma_1}{\sigma_2} \coth \left( \frac{r+is}{2} \right) + 1 \right| \geq 1 + \frac{\sigma_1}{\sigma_2} \frac{\sinh(r)}{\cosh(r) - \cos(s)}.$$

Moreover, we conclude that

$$\begin{aligned} \left| 1 - \coth \left( \frac{u-l}{\sqrt{2}\sigma_1} \sqrt{x+iy} \right) \right|^2 &= \left| 1 - \coth \left( \frac{r+is}{2} \right) \right|^2 \\ &= \left( 1 - \frac{\sinh(r)}{\cosh(r) - \cos(s)} \right)^2 + \left( \frac{\sin(s)}{\cosh(r) - \cos(s)} \right)^2 \\ &= \frac{\sinh^2(r) - 2\sinh(r)(\cosh(r) - \cos(s)) + (\cosh(r) - \cos(s))^2 + \sin^2(s)}{(\cosh(r) - \cos(s))^2} \\ &= \frac{(\cosh(r) - \sinh(r))^2 + 2\sinh(r)\cos(s) - 2\cosh(r)\cos(s) + \cos^2(s) + \sin^2(s)}{(\cosh(r) - \cos(s))^2} \\ &\leq \frac{2 - 2\cos(s)(\cosh(r) - \sinh(r))}{(\cosh(r) - \cos(s))^2} \leq \frac{2}{(\cosh(r) - \cos(s))^2}. \end{aligned}$$

Combining the estimates above, we see that

$$\begin{aligned} |\Gamma(x+iy)| &= \left| \frac{1}{\frac{\sigma_1}{\sigma_2} \coth \left( \frac{u-l}{\sqrt{2}\sigma_1} \sqrt{x+iy} \right) + 1} - \frac{\sigma_2}{\sigma_1 + \sigma_2} \right| \\ &= \left| \frac{1 - \frac{\sigma_2}{\sigma_1 + \sigma_2} \left( \frac{\sigma_1}{\sigma_2} \coth \left( \frac{u-l}{\sqrt{2}\sigma_1} \sqrt{x+iy} \right) + 1 \right)}{\frac{\sigma_1}{\sigma_2} \coth \left( \frac{u-l}{\sqrt{2}\sigma_1} \sqrt{x+iy} \right) + 1} \right| \\ &= \frac{\sigma_1}{\sigma_1 + \sigma_2} \frac{\left| 1 - \coth \left( \frac{u-l}{\sqrt{2}\sigma_1} \sqrt{x+iy} \right) \right|}{\left| \frac{\sigma_1}{\sigma_2} \coth \left( \frac{u-l}{\sqrt{2}\sigma_1} \sqrt{x+iy} \right) + 1 \right|} \\ &\leq \frac{\sigma_1}{\sigma_1 + \sigma_2} \frac{\sqrt{2}}{\cosh(r) - \cos(s)} \left( 1 + \frac{\sigma_1}{\sigma_2} \frac{\sinh(r)}{\cosh(r) - \cos(s)} \right)^{-1} \\ &= \frac{\sqrt{2}\sigma_1}{\sigma_1 + \sigma_2} \left( \cosh(r) - \cos(s) + \frac{\sigma_1}{\sigma_2} \sinh(r) \right)^{-1} \\ &\leq \frac{\sqrt{2}\sigma_1}{\sigma_1 + \sigma_2} \left( \frac{\sigma_1}{\sigma_2} \sinh(r) \right)^{-1} \\ &\leq \frac{\sqrt{2}\sigma_2}{\sigma_1 + \sigma_2} \frac{1}{\sinh \left( \frac{u-l}{\sigma_1} \sqrt{\sqrt{x^2+y^2}+x} \right)} \leq \frac{\sqrt{2}\sigma_2}{\sigma_1 + \sigma_2} \frac{1}{\sinh \left( \frac{u-l}{\sigma_1} \sqrt{|y|} \right)}. \end{aligned}$$

We apply the inequalities  $\cosh(r) - \cos(s) > 0$  (because  $r > 0$ ) and  $\sqrt{|y|} \leq \sqrt{\sqrt{x^2 + y^2} + x}$  in the last steps. We conclude that

$$\int_0^\infty |\Gamma(x + iy)| dy \leq \frac{\sqrt{2}\sigma_2}{\sigma_1 + \sigma_2} \int_0^\infty \frac{1}{\sinh\left(\frac{u-l}{\sigma_1}\sqrt{y}\right)} dy = \frac{\sqrt{2}\sigma_2}{\sigma_1 + \sigma_2} \frac{2\sigma_1^2}{(u-l)^2} \int_0^\infty \frac{y}{\sinh(y)} dy < \infty,$$

because  $y \mapsto \frac{y}{\sinh(y)}$  is continuous and integrable on  $[0, \infty)$ . Hence,  $\int_0^\infty |\Gamma(x + iy)| dy < \infty$ . In exactly the same way, one can argue that  $\int_{-\infty}^0 |\Gamma(x + iy)| dy < \infty$ . Therefore, we deduce that  $\Gamma(x + i \cdot)$  is integrable for all  $x > 0$ .

The convergence of  $\Gamma(z)$  to zero as  $z$  tends two-dimensionally to infinity follows from the estimates above: let  $\varepsilon > 0$ . Because  $\sinh(a)$  converges to  $+\infty$  as  $a \rightarrow +\infty$ , there exists an  $R > 0$  such that

$$|\Gamma(z)| = |\Gamma(x + iy)| \leq \frac{\sqrt{2}\sigma_2}{\sigma_1 + \sigma_2} \frac{1}{\sinh\left(\frac{u-l}{\sigma_1}\sqrt{\sqrt{x^2 + y^2} + x}\right)} < \varepsilon,$$

for all  $z = x + iy \in \mathbb{C}$  with  $|z| = \sqrt{x^2 + y^2} > R$  and  $x > 0$ .

*Part (iii).* Theorem 28.2 in [4] implies that there exists a continuous  $\gamma : \mathbb{R} \rightarrow \mathbb{R}$  such that  $\mathcal{L}[\gamma] = \Gamma$  and

$$\gamma(t) = \frac{1}{2\pi} \int_{-\infty}^\infty \Gamma(x + is)e^{its} ds, \quad t \in \mathbb{R}. \quad (\text{A.7})$$

Parts (i) and (ii) yield sufficient conditions for Theorem 28.2 in [4]. The right-hand side does not depend on the choice of  $x$ , and  $\gamma(t) = 0$ ,  $t \leq 0$ . Dominated convergence with dominating function given by the integrable function  $\mathbb{R} \rightarrow \mathbb{R}$ ,  $y \mapsto \frac{\sqrt{2}\sigma_2}{\sigma_1 + \sigma_2} \frac{1}{\sinh\left(\frac{u-l}{\sigma_1}\sqrt{|y|}\right)}$ , implies that we can take the limit  $x \rightarrow 0$  on the right-hand side of (A.7). We conclude that

$$\gamma(t) = \frac{1}{2\pi} \int_{-\infty}^\infty \Gamma(is)e^{its} ds, \quad t \in \mathbb{R}.$$

Note that

$$\Gamma(-is) = \frac{1}{\frac{\sigma_1}{\sigma_2} \coth\left(\frac{u-l}{\sqrt{2}\sigma_1}\sqrt{-is}\right) + 1} - \frac{\sigma_2}{\sigma_1 + \sigma_2} = \frac{1}{\frac{\sigma_1}{\sigma_2} \coth\left(\frac{u-l}{\sqrt{2}\sigma_1}\sqrt{is}\right) + 1} - \frac{\sigma_2}{\sigma_1 + \sigma_2} = \overline{\Gamma(is)},$$

for  $s \in \mathbb{R}$ , because  $\sqrt{-is} = \overline{\sqrt{is}}$  and  $\coth(\bar{z}) = \overline{\coth(z)}$ ,  $z \in \mathbb{C}$ . This implies, together with the property  $\gamma(-t) = 0$  for  $t \geq 0$ , that

$$\begin{aligned} \gamma(t) &= \gamma(t) + \gamma(-t) = \frac{1}{2\pi} \int_{-\infty}^\infty \Gamma(is) (e^{its} - e^{-its}) ds = \frac{1}{\pi} \int_{-\infty}^\infty \Gamma(is) \cos(ts) ds \\ &= \frac{1}{\pi} \int_0^\infty \Gamma(is) \cos(ts) ds + \frac{1}{\pi} \int_{-\infty}^0 \Gamma(is) \cos(ts) ds \\ &= \frac{1}{\pi} \int_0^\infty \Gamma(is) \cos(ts) ds + \frac{1}{\pi} \int_0^\infty \overline{\Gamma(is)} \cos(ts) ds = \frac{2}{\pi} \int_0^\infty \operatorname{Re}(\Gamma(is)) \cos(ts) ds, \quad t > 0. \end{aligned}$$

□



## Proof of Lemma 4.9

*Proof of Lemma 4.9.* Part (ii) follows from the symmetry of  $Q$  (see Remark 2.3) and the definition in Equation (4.8). We show Part (i) and argue why we can interchange limits or differentiation with integration or summation to show continuity and differentiability. We employ the uniform convergence of the series  $h$  defined in (1.2), dominated convergence, and the Leibniz integral rule.

*Step 1.* We show continuity of  $\hat{Q}$ : one can show that  $\hat{Q}$  is continuous on  $(0, \infty) \times \mathbb{R} \setminus \{l, u\}$ , using dominated convergence,  $g \in \mathcal{C}((0, \infty))$ , and  $h \in \mathcal{C}((0, \infty) \times \mathbb{R})$ . For example, let  $(t, x) \in (0, \infty) \times (l, u)$  and  $((t_n, x_n))_{n \in \mathbb{N}}$  be a sequence with  $\lim_{n \rightarrow \infty} (t_n, x_n) = (t, x)$ . Let  $\varepsilon > 0$ . Then, choose  $N_\varepsilon \in \mathbb{N}$  such that for all  $n \geq N_\varepsilon$ , it holds  $|(t_n, x_n) - (t, x)| < \varepsilon$  and  $x_n \in (l, u)$ . We can estimate for  $s > 0$

$$\mathbf{1}_{[0, t_n]}(s) |(\hat{g}(t_n - s) - 1)h(s, x_n)| \leq \mathbf{1}_{[0, t+\varepsilon]}(s) \max_{r \in [0, t+\varepsilon]} |\hat{g}(r) - 1| \sum_{k=-\infty}^{\infty} \frac{u-l+|k|(u-l)}{\sqrt{2\pi\sigma_1 s^{3/2}}} e^{-\frac{(k(u-l))^2}{2\sigma_1^2 s}}.$$

The right-hand side is an integrable function in  $s$  on  $[0, \infty)$ . Hence, dominated convergence implies that  $\lim_{n \rightarrow \infty} \hat{Q}(t_n, x_n) = \hat{Q}(t, x)$ , i.e.,  $\hat{Q}$  is continuous on  $(0, \infty) \times (l, u)$ . The continuity of  $\hat{Q}$  on  $(0, \infty) \times \mathbb{R} \setminus [l, u]$  can be shown similarly.

We show the continuity of  $\hat{Q}$  in the point  $x = u$ . Let  $t > 0$  and  $((t_n, x_n))_{n \in \mathbb{N}}$  be a sequence with  $\lim_{n \rightarrow \infty} (t_n, x_n) = (t, u)$  and  $x_n > u$ . Then, using integration by parts, we see that

$$\hat{Q}(t_n, x_n) = 2\hat{g}(t_n) - 2\hat{g}(0+) \Phi\left(\frac{x_n - u}{\sigma_2 \sqrt{t}}\right) - \int_0^{t_n} 2\hat{g}'(t_n - s) \Phi\left(\frac{x_n - u}{\sigma_2 \sqrt{s}}\right) ds.$$

Dominated convergence implies that

$$\begin{aligned} \lim_{n \rightarrow \infty} \hat{Q}(t_n, x_n) &= 2\hat{g}(t) - 2\hat{g}(0+) \Phi\left(\frac{x - u}{\sigma_2 \sqrt{t}}\right) - \int_0^t \hat{g}'(t - s) ds \\ &= 2\hat{g}(t) - \hat{g}(0+) - (\hat{g}(t) - \hat{g}(0+)) = \hat{g}(t). \end{aligned}$$

Similarly, let  $t > 0$  and  $((t_n, x_n))_{n \in \mathbb{N}}$  be a sequence with  $\lim_{n \rightarrow \infty} (t_n, x_n) = (t, u)$ ,  $x_n < u$ . Then

$$\begin{aligned} &\lim_{n \rightarrow \infty} \hat{Q}(t_n, x_n) \\ &= 1 + \lim_{n \rightarrow \infty} \int_0^{t_n} (\hat{g}(t_n - s) - 1) \frac{u - x_n}{\sqrt{2\pi\sigma_1 s^{3/2}}} \exp\left(-\frac{(u - x_n)^2}{2\sigma_1^2 s}\right) ds \\ &\quad + \lim_{n \rightarrow \infty} \int_0^{t_n} (\hat{g}(t_n - s) - 1) \sum_{k \neq 0} (-1)^k \frac{u - x_n + k(u - l)}{\sqrt{2\pi\sigma_1 s^{3/2}}} \exp\left(-\frac{(u - x_n + k(u - l))^2}{2\sigma_1^2 s}\right) ds \\ &= 1 + \lim_{n \rightarrow \infty} \left( 2(\hat{g}(t_n) - 1) - 2(\hat{g}(0+) - 1) \Phi\left(\frac{u - x_n}{\sigma_1 \sqrt{t_n}}\right) - \int_0^{t_n} 2\hat{g}'(t_n - s) \Phi\left(\frac{u - x_n}{\sigma_1 \sqrt{s}}\right) ds \right) \\ &\quad + \int_0^t (\hat{g}(t - s) - 1) \sum_{k \neq 0} (-1)^k \frac{k(u - l)}{\sqrt{2\pi\sigma_1 s^{3/2}}} \exp\left(-\frac{(k(u - l))^2}{2\sigma_1^2 s}\right) ds \\ &= \hat{g}(t) = \hat{Q}(t, u), \end{aligned}$$

using integration by parts, dominated convergence, and the identity

$$\sum_{k \neq 0} (-1)^k \frac{k(u - l)}{\sqrt{2\pi\sigma_1 s^{3/2}}} \exp\left(-\frac{(k(u - l))^2}{2\sigma_1^2 s}\right) = 0.$$

Hence,  $\hat{Q}$  is continuous in  $(t, u)$ . Symmetry implies that  $\hat{Q}$  is also continuous in  $(t, l)$ . Thus,  $\hat{Q} \in \mathcal{C}((0, \infty) \times \mathbb{R})$ .

*Step 2.* We show differentiability of  $\hat{Q}$  w.r.t.  $t$ : consider first the case  $x < l$ . Then,  $\hat{Q}(\cdot, x)$  is differentiable because of the *Leibniz integral rule*. We have

$$\begin{aligned}\partial_t \hat{Q}(t, x) &= \frac{l-x}{\sqrt{2\pi\sigma_2}} \int_0^t \hat{g}'(t-s) s^{-\frac{3}{2}} \exp\left(-\frac{(x-l)^2}{2s\sigma_2^2}\right) ds + \frac{l-x}{\sqrt{2\pi\sigma_2}} \hat{g}(0+) t^{-\frac{3}{2}} \exp\left(-\frac{(x-l)^2}{2t\sigma_2^2}\right) \\ &= \frac{l-x}{\sqrt{2\pi\sigma_2}} \int_0^t \hat{g}(t-s) s^{-\frac{7}{2}} \left(\frac{(l-x)^2}{2\sigma_2^2} - \frac{3}{2}s\right) \exp\left(-\frac{(x-l)^2}{2s\sigma_2^2}\right) ds, \quad t > 0.\end{aligned}$$

Moreover, we observe for  $t > 0$  and  $x \in (l, u)$  that

$$\begin{aligned}\partial_t \hat{Q}(t, x) &= \int_0^t \hat{g}'(t-s) \sum_{k=-\infty}^{\infty} (-1)^k \frac{u-x+k(u-l)}{\sqrt{2\pi\sigma_1 s^{3/2}}} e^{-\frac{(u-x+k(u-l))^2}{2\sigma_1^2 s}} ds \\ &\quad + (\hat{g}(0+) - 1) \sum_{k=-\infty}^{\infty} (-1)^k \frac{u-x+k(u-l)}{\sqrt{2\pi\sigma_1 t^{3/2}}} e^{-\frac{(u-x+k(u-l))^2}{2\sigma_1^2 t}} \\ &= \int_0^t (\hat{g}(t-s) - 1) s^{-\frac{7}{2}} \sum_{k=-\infty}^{\infty} (-1)^k \frac{u-x+k(u-l)}{\sqrt{2\pi\sigma_1}} \left(\frac{(u-x+k(u-l))^2}{2\sigma_1^2 s^{3/2}} - \frac{3}{2}s\right) e^{-\frac{(u-x+k(u-l))^2}{2\sigma_1^2 s}} ds,\end{aligned}$$

using again the Leibniz integral rule and the uniform convergence of the series (see Remark 4.3).

The symmetry of  $\hat{Q}$  in  $\frac{l+u}{2}$  implies that for  $x > u$

$$\partial_t \hat{Q}(t, x) = \frac{x-u}{\sqrt{2\pi\sigma_2}} \int_0^t \hat{g}(t-s) s^{-\frac{7}{2}} \left(\frac{(x-u)^2}{2\sigma_2^2} - \frac{3}{2}s\right) \exp\left(-\frac{(x-u)^2}{2s\sigma_2^2}\right) ds, \quad t > 0.$$

For  $x \in \{l, u\}$ , we have

$$\partial_t \hat{Q}(t, x) = \hat{g}'(t), \quad t > 0.$$

All derivatives above are continuous on  $(0, \infty) \times \mathbb{R} \setminus \{l, u\}$ , which can be shown as in Step 1.

*Step 3.* We show differentiability of  $\hat{Q}$  w.r.t.  $x$  on  $\mathbb{R} \setminus \{l, u\}$ : Similar to Step 2, we see for  $x < l$  and  $t > 0$  that

$$\begin{aligned}\partial_x \hat{Q}(t, x) &= \frac{1}{\sqrt{2\pi\sigma_2}} \int_0^t \hat{g}(t-s) s^{-\frac{3}{2}} \left(\frac{(l-x)^2}{s\sigma_2^2} - 1\right) \exp\left(-\frac{(x-l)^2}{2s\sigma_2^2}\right) ds, \quad (\text{A.8}) \\ \partial_{xx} \hat{Q}(t, x) &= \frac{(l-x)^3}{\sqrt{2\pi\sigma_2^5}} \int_0^t \hat{g}(t-s) s^{-\frac{7}{2}} \left(1 - \frac{3s\sigma_2^2}{(l-x)^2}\right) \exp\left(-\frac{(x-l)^2}{2s\sigma_2^2}\right) ds,\end{aligned}$$

using that the integrands in (4.8) are differentiable w.r.t.  $x$  and the derivatives are dominated by integrable functions locally in  $x$ . In the same way, we conclude for  $x \in (l, u)$  and  $t > 0$  that

$$\begin{aligned}\partial_x \hat{Q}(t, x) &= \int_0^t \frac{g(t-s)-1}{\sqrt{2\pi\sigma_1 s^{3/2}}} \sum_{k=-\infty}^{\infty} (-1)^k \left(\frac{(u-x+k(u-l))^2}{\sigma_1^2 s} - 1\right) e^{-\frac{(u-x+k(u-l))^2}{2\sigma_1^2 s}} ds, \quad (\text{A.9}) \\ \partial_{xx} \hat{Q}(t, x) &= \int_0^t \frac{g(t-s)-1}{s^{5/2}} \sum_{k=-\infty}^{\infty} (-1)^k \frac{u-x+k(u-l)}{\sqrt{2\pi\sigma_1^3}} \left(\frac{(u-x+k(u-l))^2}{\sigma_1^2 s} - 3\right) e^{-\frac{(u-x+k(u-l))^2}{2\sigma_1^2 s}} ds.\end{aligned}$$

For  $x > u$ , we can again use the symmetry of  $\hat{Q}$  and see for  $t > 0$  that

$$\partial_x \hat{Q}(t, x) = \frac{1}{\sqrt{2\pi\sigma_2}} \int_0^t \hat{g}(t-s) s^{-\frac{3}{2}} \left(\frac{(x-u)^2}{2s\sigma_2^2} - 1\right) \exp\left(-\frac{(x-u)^2}{2s\sigma_2^2}\right) ds,$$

$$\partial_{xx}\hat{Q}(t, x) = \frac{(x-u)^3}{\sqrt{2\pi\sigma_2^5}} \int_0^t \hat{g}(t-s)s^{-\frac{7}{2}} \left(1 - \frac{3s\sigma_2^2}{(x-u)^2}\right) \exp\left(-\frac{(x-u)^2}{2s\sigma_2^2}\right) ds.$$

The continuity of the derivatives on  $(0, \infty) \times \mathbb{R} \setminus \{l, u\}$  follows as in Step 1.

*Step 4.* We show differentiability of  $\hat{Q}$  in  $x \in \{l, u\}$ : for  $(t, x) \in (0, \infty) \times (-\infty, l)$ , we have, using Equation (A.8) and integration by parts,

$$\partial_x \hat{Q}(t, x) = \frac{2}{\sqrt{2\pi\sigma_2}} \left( \hat{g}(0+)t^{-\frac{1}{2}} \exp\left(-\frac{(l-x)^2}{2t\sigma_2^2}\right) + \int_0^t \hat{g}'(t-s)s^{-\frac{1}{2}} \exp\left(-\frac{(l-x)^2}{2s\sigma_2^2}\right) ds \right).$$

One can show that  $\partial_x \hat{Q}(t, x)$  converges as  $x \uparrow l$  and

$$\lim_{x \uparrow l} \partial_x \hat{Q}(t, x) = \frac{2}{\sqrt{2\pi\sigma_2}} \left( \hat{g}(0+)t^{-\frac{1}{2}} + \int_0^t \hat{g}'(t-s)s^{-\frac{1}{2}} ds \right), \quad t > 0.$$

The convergence is uniform in  $t$  (on compact sets). The Laplace transform of the right-hand side is given by

$$\begin{aligned} \mathcal{L} \left[ \lim_{x \uparrow l} \partial_x \hat{Q}(\cdot, x) \right] (\lambda) &= \frac{2}{\sqrt{2\pi\sigma_2}} \mathcal{L} \left[ (\cdot)^{-\frac{1}{2}} \right] (\lambda) (\hat{g}(0+) + \mathcal{L}[\hat{g}'](\lambda)) \\ &= \frac{2}{\sqrt{2\sigma_2}} \frac{1}{\sqrt{\lambda}} (\hat{g}(0+) + \lambda F(\lambda) - \hat{g}(0+)) = \frac{1}{\sigma_2} \sqrt{\frac{2}{\lambda}} \lambda F(\lambda) = \frac{1}{\sigma_2} \sqrt{\frac{2}{\lambda}} \frac{1}{\frac{\sigma_1}{\sigma_2} \coth\left(\frac{u-l}{\sqrt{2}\sigma_1} \sqrt{\lambda}\right) + 1}, \end{aligned}$$

for  $\lambda > 0$ . In the case  $x \in (l, u)$ , we apply integration by parts to Equation (A.9) and see that

$$\partial_x \hat{Q}(t, x) = \sum_{k=-\infty}^{\infty} (-1)^k \left( \frac{2(\hat{g}(0+) - 1)}{\sqrt{2\pi t \sigma_1}} e^{-\frac{(u-x+k(u-l))^2}{2t\sigma_1^2}} + \int_0^t \frac{2\hat{g}'(t-s)}{\sqrt{2\pi s \sigma_1}} e^{-\frac{(u-x+k(u-l))^2}{2s\sigma_1^2}} ds \right),$$

for  $t > 0$ . One can show that  $\partial_x \hat{Q}(t, x)$  converges as  $x \downarrow l$  and

$$\begin{aligned} &\lim_{x \downarrow l} \partial_x \hat{Q}(t, x) \\ &= \frac{2(\hat{g}(0+) - 1)}{\sqrt{2\pi t \sigma_1}} \sum_{k=-\infty}^{\infty} (-1)^k e^{-\frac{((k+1)(u-l))^2}{2t\sigma_1^2}} + \int_0^t \frac{2\hat{g}'(t-s)}{\sqrt{2\pi s \sigma_1}} \sum_{k=-\infty}^{\infty} (-1)^k e^{-\frac{((k+1)(u-l))^2}{2s\sigma_1^2}} ds \\ &= -\frac{2(\hat{g}(0+) - 1)}{\sqrt{2\pi t \sigma_1}} \sum_{k=-\infty}^{\infty} (-1)^k e^{-\frac{(k(u-l))^2}{2t\sigma_1^2}} - 2 \int_0^t \frac{\hat{g}'(t-s)}{\sqrt{2\pi s \sigma_1}} \sum_{k=-\infty}^{\infty} (-1)^k e^{-\frac{(k(u-l))^2}{2s\sigma_1^2}} ds \\ &= -\frac{2(\hat{g}(0+) - 1)}{\sqrt{2\pi t \sigma_1}} - \frac{4(\hat{g}(0+) - 1)}{\sqrt{2\pi t \sigma_1}} \sum_{k=1}^{\infty} (-1)^k e^{-\frac{(k(u-l))^2}{2t\sigma_1^2}} - \frac{2}{\sqrt{2\pi \sigma_1}} \int_0^t \hat{g}'(t-s)s^{-\frac{1}{2}} ds \\ &\quad - \frac{4}{\sqrt{2\pi \sigma_1}} \int_0^t \hat{g}'(t-s)s^{-\frac{1}{2}} \sum_{k=1}^{\infty} (-1)^k e^{-\frac{(k(u-l))^2}{2s\sigma_1^2}} ds, \quad t > 0. \end{aligned}$$

The convergence is uniform in  $t$  (on compact sets). The Laplace transformation of this identity is given by

$$\begin{aligned} &-\mathcal{L} \left[ \lim_{x \downarrow l} \partial_x \hat{Q}(\cdot, x) \right] (\lambda) \\ &= \frac{2(\hat{g}(0+) - 1)}{\sqrt{2\pi \sigma_1}} \mathcal{L} \left[ (\cdot)^{-\frac{1}{2}} \right] (\lambda) + \frac{4(\hat{g}(0+) - 1)}{\sqrt{2\pi \sigma_1}} \sum_{k=1}^{\infty} (-1)^k \mathcal{L} \left[ (\cdot)^{-\frac{1}{2}} \exp\left(-\frac{(k(u-l))^2}{2\sigma_1^2(\cdot)}\right) \right] (\lambda) \end{aligned}$$

$$\begin{aligned}
& + \frac{2}{\sqrt{2\pi}\sigma_1} \mathcal{L} [\hat{g}'] (\lambda) \mathcal{L} [(\cdot)^{-\frac{1}{2}}] + \frac{4}{\sqrt{2\pi}\sigma_1} \sum_{k=1}^{\infty} (-1)^k \mathcal{L} [\hat{g}'] (\lambda) \mathcal{L} \left[ (\cdot)^{-\frac{1}{2}} \exp \left( -\frac{(k(u-l))^2}{2\sigma_1^2(\cdot)} \right) \right] (\lambda) \\
& = \frac{\hat{g}(0+) - 1}{\sigma_1} \sqrt{\frac{2}{\lambda}} \left( 1 + 2 \sum_{k=1}^{\infty} (-1)^k \exp \left( -\frac{k(u-l)}{\sigma_1} \sqrt{2\lambda} \right) \right) \\
& \quad + \frac{1}{\sigma_1} \sqrt{\frac{2}{\lambda}} (\lambda F(\lambda) - \hat{g}(0+)) \left( 1 + 2 \sum_{k=1}^{\infty} (-1)^k \exp \left( -\frac{k(u-l)}{\sigma_1} \sqrt{2\lambda} \right) \right) \\
& = \sqrt{\frac{2}{\lambda}} \frac{1}{\sigma_1} (\hat{g}(0+) - 1 + \lambda F(\lambda) - \hat{g}(0+)) \left( 1 + 2 \sum_{k=1}^{\infty} (-1)^k \exp \left( -\frac{k(u-l)}{\sigma_1} \sqrt{2\lambda} \right) \right) \\
& = \sqrt{\frac{2}{\lambda}} \frac{1}{\sigma_1} (\lambda F(\lambda) - 1) \left( 1 + 2 \sum_{k=1}^{\infty} (-1)^k \exp \left( -\frac{k(u-l)}{\sigma_1} \sqrt{2\lambda} \right) \right) \\
& = \sqrt{\frac{2}{\lambda}} \frac{1}{\sigma_1} (\lambda F(\lambda) - 1) \left( -1 + \frac{2}{1 + \exp \left( -\frac{u-l}{\sigma_1} \sqrt{2\lambda} \right)} \right) \\
& = \sqrt{\frac{2}{\lambda}} \frac{1}{\sigma_1} (\lambda F(\lambda) - 1) \tanh \left( \frac{u-l}{\sqrt{2}\sigma_1} \sqrt{\lambda} \right) \\
& = \sqrt{\frac{2}{\lambda}} \frac{1}{\sigma_1} \frac{-\frac{\sigma_1}{\sigma_2} \coth \left( \frac{u-l}{\sqrt{2}\sigma_1} \sqrt{\lambda} \right)}{\frac{\sigma_1}{\sigma_2} \coth \left( \frac{u-l}{\sqrt{2}\sigma_1} \sqrt{\lambda} \right) + 1} \tanh \left( \frac{u-l}{\sqrt{2}\sigma_1} \sqrt{\lambda} \right) = -\sqrt{\frac{2}{\lambda}} \frac{1}{\sigma_2} \frac{1}{\frac{\sigma_1}{\sigma_2} \coth \left( \frac{u-l}{\sqrt{2}\sigma_1} \sqrt{\lambda} \right) + 1},
\end{aligned}$$

for  $\lambda > 0$ . Hence, we conclude  $\mathcal{L}[\lim_{x \downarrow l} \partial_x \hat{Q}(\cdot, x)] = \mathcal{L}[\lim_{x \uparrow l} \partial_x \hat{Q}(\cdot, x)]$ . The injectivity of the Laplace transformation implies that

$$\lim_{x \downarrow l} \partial_x \hat{Q}(t, x) = \lim_{x \uparrow l} \partial_x \hat{Q}(t, x), \quad t > 0,$$

(see, e.g., [4], Theorem 5.4) because  $\partial_x \hat{Q}$  is continuous on  $(0, \infty) \times \mathbb{R} \setminus \{l, u\}$  and the limits are uniform in  $t$  (on compact sets). Hence, the derivative  $\partial_x \hat{Q}(t, l)$  exists and  $\partial_x \hat{Q}$  is continuous on  $(0, \infty) \times \mathbb{R} \setminus \{l, u\}$ . Symmetry implies that  $\lim_{x \uparrow u} \partial_x \hat{Q}(t, x) = \lim_{x \downarrow u} \partial_x \hat{Q}(t, x)$ . Finally, we have  $\hat{Q} \in \mathcal{C}^{1,2}((0, \infty) \times \mathbb{R} \setminus \{l, u\}) \cap \mathcal{C}^{0,1}((0, \infty) \times \mathbb{R})$ .  $\square$

## Acknowledgments

Support from the German Research Foundation through the project AN 1024/5-1 is gratefully acknowledged.

**Conflict of Interest** The authors have no relevant financial or non-financial interests to disclose.

**Data Availability** Data sharing is not applicable to this article as no datasets were generated or analyzed during the current study.

## References

- [1] G. Alsmeyer and M. Jaeger. A useful extension of Itô's formula with applications to optimal stopping. *Acta Mathematica Sinica (English Series)*, 21(4):779–786, 2005.

- [2] S. Ankirchner, C. Blanchet-Scalliet, and M. Jeanblanc. Controlling the occupation time of an exponential martingale. *Applied Mathematics and Optimization*, 76(2):415–428, 2017.
- [3] A. N. Borodin and P. Salminen. *Handbook of Brownian Motion—Facts and Formulae*. Probability and its Applications. Birkhäuser Verlag, Basel, second edition, 2002.
- [4] G. Doetsch. *Introduction to the theory and application of the Laplace transformation*. Springer-Verlag, New York-Heidelberg, 1974. Translated from the second German edition by Walter Nader.
- [5] E. B. Fabes and C. E. Kenig. Examples of singular parabolic measures and singular transition probability densities. *Duke Mathematical Journal*, 48(4):845–856, 1981.
- [6] I. Karatzas and S. E. Shreve. *Brownian motion and stochastic calculus*, volume 113 of *Graduate Texts in Mathematics*. Springer-Verlag, New York, second edition, 1991.
- [7] N. V. Krylov. *Controlled diffusion processes*, volume 14 of *Stochastic Modelling and Applied Probability*. Springer-Verlag, Berlin, 2009. Translated from the 1977 Russian original by A. B. Aries, Reprint of the 1980 edition.
- [8] P. Krühner and S. Xu. A sharp upper bound for the expected occupation density of itô processes with bounded irregular drift and diffusion coefficients. Oct. 2023.
- [9] J. M. McNamara. Optimal control of the diffusion coefficient of a simple diffusion process. *Mathematics of Operations Research*, 8(3):373–380, 1983.
- [10] J. M. McNamara. A regularity condition on the transition probability measure of a diffusion process. *Stochastics*, 15(3):161–182, 1985.
- [11] S. Nakao. On the pathwise uniqueness of solutions of one-dimensional stochastic differential equations. *Osaka Journal of Mathematics*, 9(3):513–518, 1972.