



HAL
open science

A sharp upper bound for the expected interval occupation time of Brownian martingales

Stefan Ankirchner, Julian Wendt

► **To cite this version:**

Stefan Ankirchner, Julian Wendt. A sharp upper bound for the expected interval occupation time of Brownian martingales. 2021. hal-03138433

HAL Id: hal-03138433

<https://hal.science/hal-03138433>

Preprint submitted on 11 Feb 2021

HAL is a multi-disciplinary open access archive for the deposit and dissemination of scientific research documents, whether they are published or not. The documents may come from teaching and research institutions in France or abroad, or from public or private research centers.

L'archive ouverte pluridisciplinaire **HAL**, est destinée au dépôt et à la diffusion de documents scientifiques de niveau recherche, publiés ou non, émanant des établissements d'enseignement et de recherche français ou étrangers, des laboratoires publics ou privés.

A sharp upper bound for the expected interval occupation time of Brownian martingales

Stefan Ankirchner Julian Wendt

February 11, 2021

Abstract

We consider Brownian integral processes with integrands that are bounded and bounded away from zero. We provide an upper estimate for the expected occupation time in an interval. The estimate does not depend on the integrand but only on its bounds. We derive the estimate by solving a stochastic control problem that consists in maximizing the expected occupation time in an interval.

1 Introduction and main result

Let W be a Brownian motion defined on a complete probability space $(\Omega, \mathcal{F}, \mathbb{P})$ and let $(\mathcal{F}_t)_{t \geq 0}$ be its augmented Brownian filtration. Let $0 < \sigma_1 \leq \sigma_2$. We denote by \mathcal{A} the set of progressively measurable processes with values in the interval $[\sigma_1, \sigma_2]$.

Let $l, u \in \mathbb{R}$ with $l < u$, and $x \in \mathbb{R}$. Consider the class of Brownian martingales

$$X_t = x + \int_0^t \alpha_s dW_s, \quad t \in [0, \infty), \quad (1)$$

with $\alpha \in \mathcal{A}$. We provide a bound, independent of α , for the expected time the Brownian martingale X spends in the interval $[l, u]$ until some time $t \in (0, \infty)$. The bound depends only on $\sigma_1, \sigma_2, l, u, x$ and the time horizon t .

To describe the bound, we define a function $h : (0, \infty) \times \mathbb{R} \rightarrow \mathbb{R}$ by

$$h(s, x) = \sum_{k=-\infty}^{\infty} (-1)^k \frac{u - x + k(u - l)}{\sqrt{2\pi\sigma_1 s^{\frac{3}{2}}}} \exp\left(-\frac{(u - x + k(u - l))^2}{2\sigma_1^2 s}\right) \quad (2)$$

and a function $\hat{g} : (0, \infty) \rightarrow \mathbb{R}$ by

$$\hat{g}(t) := \frac{1}{\pi} \int_0^\infty \frac{e^{-st}}{s} \frac{1}{\frac{\sigma_1}{\sigma_2} \cot\left(\frac{u-l}{\sqrt{2}\sigma_1} \sqrt{s}\right) + \frac{\sigma_2}{\sigma_1} \tan\left(\frac{u-l}{\sqrt{2}\sigma_1} \sqrt{s}\right)} ds, \quad t > 0. \quad (3)$$

The following is the main result.

Theorem 1.1. *Let $\alpha \in \mathcal{A}$ and $X_t = x + \int_0^t \alpha_s dW_s$. Then*

$$\int_0^t P(X_s \in [l, u]) ds \leq \begin{cases} t - \int_0^t \int_0^r (1 - \hat{g}(r - s)) h(s, x) ds dr, & \text{if } x \in (l, u), \\ \frac{d(x, I)}{\sqrt{2\pi\sigma_2}} \int_0^t \int_0^r \hat{g}(r - s) s^{-\frac{3}{2}} \exp\left(-\frac{d(x, I)^2}{2\sigma_2^2 r}\right) dr ds, & \text{if } x \notin (l, u), \\ \int_0^t \hat{g}(s) ds, & \text{if } x \in \{l, u\}, \end{cases} \quad (4)$$

where $d(x, I) := \inf_{y \in [l, u]} |x - y|$ denotes the usual distance of the point x to the interval $I = [l, u]$. Moreover, the bound is sharp, i.e. there exists an $\alpha \in \mathcal{A}$ for which the inequality is an equality.

We prove Theorem 1.1 by studying the control problem with control set \mathcal{A} , with controlled dynamics (1) and with the target to maximize the expected occupation time of X in the interval $[l, u]$. We compute an explicit solution of the associated HJB equation and solve the control problem via a verification method. We also prove that the optimal control is a Markov control that consists in choosing the maximal volatility outside the interval $[l, u]$ and the minimal volatility inside. In Section 2 below we describe the control problem in more detail.

The problem of maximizing the occupation time in *unbounded* intervals of the form $[l, \infty)$ or $(-\infty, u]$ has been studied in the literature already: for Brownian martingale in [6] (see Remark 8), and for exponential martingales in [1]. In the current paper we analyze the expected occupation time within *bounded* intervals.

As in [1], we first describe a candidate for the value function in terms of its Laplace transform in Section 3 and we use the Laplace transform for verifying that the candidate coincides with the value function. By inverting the Laplace transform we arrive at the bound provided in Theorem 1.1.

2 The control problem

In this section we describe the control problem that we use for deriving the occupation time bound given in Theorem 1.1.

We use the same notation and make the same assumptions as in Section 1. For every $x \in \mathbb{R}$, $s \in [0, \infty)$ and $\alpha \in \mathcal{A}$ we denote by $X^{s,x,\alpha}$ the process on $[s, \infty)$ defined by

$$X_r^{s,x,\alpha} = x + \int_s^r \alpha_u dW_u, \quad r \in [s, \infty). \quad (5)$$

For a fixed time horizon $t > 0$ and $l, u \in \mathbb{R}$, $l < u$, we consider the problem of maximizing the occupation time of the process $X^{0,x,\alpha}$ in the interval $[l, u]$ up to time t . In other words, we want to maximize the target function

$$J(t, x, \alpha) := \int_0^t \mathbb{P}(X_s^{0,x,\alpha} \in [l, u]) ds$$

over all $\alpha \in \mathcal{A}$, and determine the value function

$$v(t, x) := \sup_{\alpha \in \mathcal{A}} J(t, x, \alpha). \quad (6)$$

We call a strategy $\alpha \in \mathcal{A}$ *feedback control* if there exist a function $a : \mathbb{R} \rightarrow [\sigma_1, \sigma_2]$ such that $\alpha_s = a(X_s^{0,x,a})$, where $X^{0,x,a}$ denotes the solution to the SDE

$$dX_r = a(X_r) dW_r, \quad X_0 = x. \quad (7)$$

Note that a strong solution of (7) exists if the function a is of bounded variation on any compact interval: Since a is uniformly bounded away from zero there exists a weak solution to (7) according to Theorem 2.6.1 in [5]; moreover, due to results in [7] pathwise uniqueness applies, and hence there exists a unique strong solution to (7) (cf. Section 5.3 in [4]).

We show that the optimal control is to choose the maximal volatility if the process is outside the interval $[l, u]$, and to choose the minimal volatility if the processes is inside the interval $[l, u]$. To give a rigorous definition, let $\hat{a} : \mathbb{R} \rightarrow [\sigma_1, \sigma_2]$ be defined by

$$\hat{a}(x) = \begin{cases} \sigma_1, & x \in [l, u], \\ \sigma_2, & \text{else,} \end{cases}$$

and set $\hat{\alpha}_s := \hat{a}(X_s^{0,x,\hat{a}})$, $s \geq 0$. Note that $\hat{\alpha}$ is a feedback control of bang-bang type.

The solution of the control problem is provided by the following theorem.

Theorem 2.1. *The control $\hat{\alpha}$ is an optimal control for problem (6). The Laplace transform of the value function satisfies*

$$\mathcal{L}[v(\cdot, x)](\lambda) = \begin{cases} \frac{1}{\lambda^2} \frac{1}{\frac{\sigma_1}{\sigma_2} \coth\left(\frac{u-l}{2\sigma_1}\sqrt{2\lambda}\right) + 1} \exp\left(\frac{\sqrt{2\lambda}}{\sigma_2}(x-l)\right), & x < l, \\ \frac{1}{\lambda^2} \left(1 - \frac{\cosh\left(\frac{2x-(u+l)}{2\sigma_1}\sqrt{2\lambda}\right)}{\cosh\left(\frac{u-l}{2\sigma_1}\sqrt{2\lambda}\right) + \frac{\sigma_2}{\sigma_1} \sinh\left(\frac{u-l}{2\sigma_1}\sqrt{2\lambda}\right)}\right), & x \in [l, u], \\ \frac{1}{\lambda^2} \frac{1}{\frac{\sigma_1}{\sigma_2} \coth\left(\frac{u-l}{2\sigma_1}\sqrt{2\lambda}\right) + 1} \exp\left(-\frac{\sqrt{2\lambda}}{\sigma_2}(x-u)\right), & x > u. \end{cases} \quad (8)$$

Remark 2.2. We stress that the control $\hat{\alpha}$ does not maximize the probability for the state to be in the interval $[l, u]$ at the terminal time t . In other words, it is not an optimal control in the case of maximizing the probability $\mathbb{P}(X_t^{0,x,\alpha} \in [l, u])$. One can show by numerical calculations that the candidate for the value function obtained with the feedback control function $\hat{\alpha}$ does not have the required convexity and concavity properties to satisfy the HJB equation.

We postpone the proof of Theorem 2.1 to Section 5. We apply standard verification techniques to establish the optimality of $\hat{\alpha}$ and to determine the value function. However, since it is difficult to solve the HJB equation of the control problem (6) directly, we use a Laplace transform in order to turn the HJB equation into a second order ODE. The ODE coincides with the HJB equation of a control problem version with an infinite time horizon. We first solve the infinite time horizon problem. The inverse Laplace transformation then allows us to derive a candidate for the value function with which one can perform the verification.

We define

$$Q(t, x) := \mathbb{P}(X_t^{0,x,\hat{\alpha}} \in [l, u]), \quad (t, x) \in [0, \infty) \times \mathbb{R}. \quad (9)$$

The function Q will help to determine a candidate for the value function. In particular, we aim at showing that $w(x) = \int_0^t Q(s, x) ds$ equals the value function by verification arguments. Hence, it is sufficient to determine Q (or a suitable version \hat{Q}) and perform a verification using this identity in order to show that $\hat{\alpha}$ is optimal. To this end, we study the Laplace transform $\mathcal{L}[Q(\cdot, x)]$. Note that

$$\mathcal{L}[Q(\cdot, x)](\lambda) = \int_0^\infty e^{-\lambda t} Q(t, x) dt = \int_0^\infty e^{-\lambda t} \mathbb{P}(X_t^{0,x,\hat{\alpha}} \in [l, u]) dt. \quad (10)$$

The right-hand side of this equation reminds of a discounted infinite time horizon control problem. We study this problem in the next section.

At last, we have the following remark:

Remark 2.3. The function $Q(t, \cdot)$ is symmetric in the point $\frac{l+u}{2}$, i.e. $Q(t, \frac{l+u}{2} + x) = Q(t, \frac{l+u}{2} - x)$ for all $(t, x) \in [0, \infty) \times \mathbb{R}$.

3 A control problem with infinite time horizon

Let $\lambda > 0$. We define for any control $\alpha \in \mathcal{A}$ the target function

$$K(x, \alpha, \lambda) := \int_0^\infty e^{-\lambda t} \mathbb{P}(X_t^{x,\alpha} \in [l, u]) dt, \quad (11)$$

where the process $X^{x,\alpha}$ is governed by the stochastic differential equation

$$dX_t^{x,\alpha} = \alpha_t dW_t, \quad X_0 = x, \quad \alpha \in \mathcal{A}.$$

Moreover, we define the value function by

$$V(x, \lambda) := \sup_{\alpha \in \mathcal{A}} K(x, \alpha, \lambda). \quad (12)$$

For the sake of simplicity we sometimes write $V(x)$ and $K(x, \alpha)$ and omit the dependence on the parameter λ when it is convenient. The control problem consists of maximizing the target function K over all admissible controls $\alpha \in \mathcal{A}$, i.e. we want to find a control $\alpha \in \mathcal{A}$ such that $K(x, \alpha) = V(x)$. A control satisfying this property is called *optimal*.

Remark 3.1. Note that one can also study the control problem of maximizing $\mathbb{P}(X_\tau^{x, \alpha} \in [l, u])$, where $T > 0$ and $\tau \sim \text{Exp}(\lambda)$ is independent of the Brownian motion W . Then one can write the cost functional as

$$\mathbb{P}(X_\tau^{x, \alpha} \in [l, u]) = \int_0^\infty \lambda e^{-\lambda t} \mathbb{P}(X_t^{x, \alpha} \in [l, u]) dt.$$

This term is equal to the target function K defined in (11) except for the factor λ . Hence, solving the problem above also yields an optimal control for the problem with exponential stopping.

As in the previous section, we suspect that the feedback control $\hat{\alpha}_t = \hat{\alpha}(X_t^{x, \alpha})$ is the optimal control for (12). To verify this conjecture we consider the HJB equation of (12), which is given by

$$\lambda V(x) - \mathbf{1}_{[l, u]}(x) - \sup_{b \in [\sigma_1, \sigma_2]} \frac{b^2}{2} V''(x) = 0 \quad (13)$$

Note that (13) is an ODE, in contrast to the HJB equation of the control problem (6), which is a PDE. We can even determine the solution explicitly and confirm that $\hat{\alpha}$ is really optimal. We derive a candidate for value function and perform a classical verification with this candidate.

Assume that the value function V satisfies the HJB equation (13). The definition of K in (11) implies that $\lambda V(x) \leq 1$ for all $x \in \mathbb{R}$. This yields that V is concave on $[l, u]$, and convex otherwise. Moreover, V solves the following equations

$$\lambda V(x) - 1 - \frac{\sigma_1^2}{2} V''(x) = 0, \quad x \in (l, u), \quad (14)$$

$$\lambda V(x) - \frac{\sigma_2^2}{2} V''(x) = 0, \quad x \notin [l, u]. \quad (15)$$

This implies that we have to solve (14) and (15) with appropriate constraints. We have the following:

Lemma 3.2. *Let $\beta_i := \frac{\sqrt{2\lambda}}{\sigma_i}$ for $i = 1, 2$. A general solution of (14) and (15) is given by*

$$G(x) = \begin{cases} C_1 e^{+\beta_2 x} + C_2 e^{-\beta_2 x}, & x < l \\ \frac{1}{\lambda} + C_3 e^{+\beta_1 x} + C_4 e^{-\beta_1 x}, & x \in [l, u], \\ C_5 e^{+\beta_2 x} + C_6 e^{-\beta_2 x}, & x > u. \end{cases}$$

Proof. Straightforward calculations. □

Now, it remains to determine the right constants in order to construct a candidate for the value function. The boundedness of the value function which follows directly from its definition implies that $C_2 = C_5 = 0$. Moreover, the symmetry of $Q(t, \cdot)$ in $\frac{u+l}{2}$ implies that also the value function

inherits this symmetry (see Remark 2.3). In addition, we require $G \in \mathcal{C}^1(\mathbb{R}) \cap \mathcal{C}^2(\mathbb{R} \setminus \{l, u\})$. All these conditions uniquely determine the constants C_1, \dots, C_6 above entailing the definition

$$G(x, \lambda) := \begin{cases} \frac{1}{\lambda} \frac{1}{\frac{\sigma_1}{\sigma_2} \coth\left(\frac{u-l}{2\sigma_1}\sqrt{2\lambda}\right) + 1} \exp\left(\frac{\sqrt{2\lambda}}{\sigma_2}(x-l)\right), & x < l, \\ \frac{1}{\lambda} \left(1 - \frac{\cosh\left(\frac{2x-(u+l)}{2\sigma_1}\sqrt{2\lambda}\right)}{\cosh\left(\frac{u-l}{2\sigma_1}\sqrt{2\lambda}\right) + \frac{\sigma_2}{\sigma_1} \sinh\left(\frac{u-l}{2\sigma_1}\sqrt{2\lambda}\right)}\right), & x \in [l, u], \\ \frac{1}{\lambda} \frac{1}{\frac{\sigma_1}{\sigma_2} \coth\left(\frac{u-l}{2\sigma_1}\sqrt{2\lambda}\right) + 1} \exp\left(-\frac{\sqrt{2\lambda}}{\sigma_2}(x-u)\right), & x > u. \end{cases} \quad (16)$$

Then the following holds true:

Proposition 3.3. *We have $V(x, \lambda) = G(x, \lambda)$. Moreover, the feedback control $\hat{\alpha}_t = a(X_t)$ is optimal for (12).*

Proof. Let $\alpha \in \mathcal{A}$ be an arbitrary control and X be the associated controlled process. By Itô's formula for \mathcal{C}^1 functions with absolutely continuous derivatives (see e.g. Section 3.7 in [4]) we obtain

$$e^{-\lambda t} G(X_t) = G(x) + \int_0^t e^{-\lambda s} \alpha_s G'(X_s) dW_s + \int_0^t e^{-\lambda s} \left(\frac{\alpha_s^2}{2} G''(X_s) - \lambda G(X_s) \right) ds.$$

Localizing the terms and taking expectations implies that

$$\mathbb{E} \left[e^{-\lambda t} G(X_t) \right] = G(x) + \mathbb{E} \left[\int_0^t e^{-\lambda s} \left(\frac{\alpha_s^2}{2} G''(X_s) - \lambda G(X_s) \right) ds \right]. \quad (17)$$

Since G is concave on $[l, u]$ and convex on $\mathbb{R} \setminus [l, u]$ we see that

$$\frac{\alpha_s^2}{2} G''(x) - \lambda G(x) \leq -\mathbb{1}_{[l, u]}(x), \quad (s, x) \in [0, \infty) \times \mathbb{R} \setminus \{l, u\},$$

using that G solves the ODEs (14) and (15). Thus, we can plug this estimate into (17) and obtain

$$\mathbb{E} \left[e^{-\lambda t} G(X_t) \right] \leq G(x) - \left[\int_0^t e^{-\lambda s} \mathbb{P}(X_s \in [l, u]) ds \right]. \quad (18)$$

Dominated convergence implies that the left-hand side of (18) converges to zero when $t \rightarrow \infty$ since $|G|$ is bounded by the constant $\frac{1}{\lambda}$. Consequently, $V(x) \leq G(x)$ because the choice of α was arbitrary.

Repeating the above reasoning for $\hat{\alpha}$ we obtain equality in (18) and $G(x) = K(x, \hat{\alpha}) \leq V(x)$. Finally, $G = V$ and $\hat{\alpha}$ is optimal. \square

4 Transferring the results to the original problem

Now, we want to connect the control problems from Section 2 and 3. The definition of Q in (9) and Proposition 3.3 immediately entail:

Corollary 4.1. $\mathcal{L}[Q(\cdot, x)](\lambda) = V(x, \lambda)$ for all $(x, \lambda) \in \mathbb{R} \times (0, \infty)$.

This Corollary implies that we can deduce a formula for Q via the inverse Laplace transform. Let $X^{s,x}$ denote the solution of (7) controlled by the feedback control $\hat{a}(X_t^{s,x})$ and starting at time $s \geq 0$ in $x \in \mathbb{R}$. We define $g(t) := Q(t, l)$ for $t \geq 0$. Note that due to symmetry we also have $g(t) = Q(t, u)$, $t \geq 0$, (see Remark 2.3). The strong Markov property of $X^{s,x}$ (see, e.g., Theorem 4.20, Chapter 5 in [4]) entails that it is enough to calculate the Laplace inverse of $V(l, \lambda)$. This significantly reduces the complexity of the calculation of Q . Nevertheless, the results are not immediate.

Lemma 4.2. *For all $(t, x) \in [0, \infty) \times \mathbb{R} \setminus \{l, u\}$ we have*

$$Q(t, x) = \begin{cases} \frac{l-x}{\sqrt{2\pi}\sigma_2} \int_0^t g(t-s) s^{-\frac{3}{2}} \exp\left(-\frac{(x-l)^2}{2\sigma_2^2 s}\right) ds, & x < l, \\ 1 + \int_0^t (g(t-s) - 1) \mathcal{L}^{-1} \left[\frac{\cosh\left(\frac{1}{2\sigma_1}(u+l-2x)\sqrt{2\cdot}\right)}{\cosh\left(\frac{1}{2\sigma_1}(u-l)\sqrt{2\cdot}\right)} \right] (s) ds, & x \in (l, u), \\ \frac{x-u}{\sqrt{2\pi}\sigma_2} \int_0^t g(t-s) s^{-\frac{3}{2}} \exp\left(-\frac{(x-u)^2}{2\sigma_2^2 s}\right) ds, & x > r. \end{cases} \quad (19)$$

Remark 4.3. Note that we can write the Laplace inverse in (19) as the two-sided series (2), i.e. we have

$$\mathcal{L}^{-1} \left[\frac{\cosh\left(\frac{1}{2\sigma_1}(u+l-2x)\sqrt{2\cdot}\right)}{\cosh\left(\frac{1}{2\sigma_1}(u-l)\sqrt{2\cdot}\right)} \right] (s) = h(s, x), \quad x \in (l, u), \quad (20)$$

see e.g. [2], Appendix 3. This series converges uniformly, and even the series over the differentiated summands converges uniformly. Therefore, we can calculate integrals or derivatives of this series by just integrating or differentiating the summands, respectively.

Proof of Lemma 4.2. 1. Let $x \in (l, u)$ and $\tau(x)$ be the first exit time of $X^{0,x}$ of the interval $[l, u]$, i.e. $\tau(x) := \inf\{s \geq 0 : X_s^{0,x} \notin (l, u)\}$. Note that $X^{0,x}$ is a BM with volatility σ_1 up to time $\tau(x)$ and $\tau(x)$ has the density function

$$p_{\tau(x)}(s) = \left[\mathcal{L}^{-1} \left(\frac{\cosh\left(\frac{1}{2\sigma_1}(u+l-2x)\sqrt{2\cdot}\right)}{\cosh\left(\frac{1}{2\sigma_1}(u-l)\sqrt{2\cdot}\right)} \right) \right] (s),$$

(see e.g. [2], Section II.1.3). By the strong Markov property of $X^{0,x}$ we then have for $t > 0$

$$\begin{aligned} Q(t, x) &= \mathbb{P}\left(\tau(x) \leq t, X_t^{0,x} \in [l, u]\right) + \mathbb{P}\left(\tau(x) > t, X_t^{0,x} \in [l, u]\right) \\ &= \mathbb{E}\left[\mathbf{1}_{\{\tau(x) \leq t\}} \mathbb{E}\left[\mathbf{1}_{[l, u]}(X_t^{0,x}) | \mathcal{F}_\tau\right]\right] + \mathbb{P}(\tau(x) > t) \\ &= \mathbb{E}\left[\mathbf{1}_{\{\tau(x) \leq t\}} \mathbb{E}\left[\mathbf{1}_{[l, u]}(X_t^{s,y}) \Big|_{s=\tau(x), y=X_\tau}\right]\right] + \mathbb{P}(\tau(x) > t) \\ &= \mathbb{E}\left[\mathbf{1}_{\{\tau(x) \leq t\}} \mathbb{E}\left[\mathbf{1}_{[l, u]}(X_{t-s}^{0,y}) \Big|_{s=\tau(x), y=X_\tau}\right]\right] + \mathbb{P}(\tau(x) > t) \\ &= \mathbb{E}\left[\mathbf{1}_{\{\tau(x) \leq t, X_\tau=l\}} \mathbb{E}\left[\mathbf{1}_{[l, u]}(X_{t-s}^{0,l}) \Big|_{s=\tau(x)}\right]\right] + \mathbb{E}\left[\mathbf{1}_{\{\tau(x) \leq t, X_\tau=u\}} \mathbb{E}\left[\mathbf{1}_{[l, u]}(X_{t-s}^{0,u}) \Big|_{s=\tau(x)}\right]\right] \\ &\quad + \mathbb{P}(\tau(x) > t) \\ &= \mathbb{E}\left[\mathbf{1}_{\{\tau(x) \leq t, X_\tau=l\}} g(t-\tau(x))\right] + \mathbb{E}\left[\mathbf{1}_{\{\tau(x) \leq t, X_\tau=u\}} g(t-\tau(x))\right] + \mathbb{P}(\tau(x) > t) \\ &= \mathbb{E}\left[\mathbf{1}_{\{\tau(x) \leq t\}} g(t-\tau(x))\right] + \mathbb{P}(\tau(x) > t) \\ &= \int_0^t g(t-s) p_{\tau(x)}(s) ds + \mathbb{P}(\tau(x) > t) \end{aligned}$$

$$\begin{aligned}
&= 1 + \int_0^t (g(t-s) - 1) p_{\tau(x)}(s) ds \\
&= 1 + \int_0^t (g(t-s) - 1) \mathcal{L}^{-1} \left[\frac{\cosh \left(\frac{1}{2\sigma_1} (u+l-2x) \sqrt{2\cdot} \right)}{\cosh \left(\frac{1}{2\sigma_1} (u-l) \sqrt{2\cdot} \right)} \right] (s) ds.
\end{aligned}$$

2. Let $x < l$ and $\tau_l(x)$ be the first hitting time of l of the process $X^{0,x}$. Note that $X^{0,x}$ is a Brownian motion with volatility σ_2 up to time $\tau_l(x)$. $\tau_l(x)$ has the density

$$p_{\tau_l(x)}(t) = \frac{l-x}{\sqrt{2\pi\sigma_2} t^{\frac{3}{2}}} \exp\left(-\frac{(x-l)^2}{2\sigma_2^2 t}\right),$$

(see e.g. [2], Section II.1.2). Again the strong Markov property implies that for $t > 0$

$$\begin{aligned}
Q(t, x) &= \mathbb{P}\left(\tau_l(x) \leq t, X_t^{0,x} \in [l, u]\right) + \mathbb{P}\left(\tau_l(x) > t, X_t^{0,x} \in [l, u]\right) \\
&= \mathbb{E}\left[\mathbb{1}_{\{\tau_l(x) \leq t\}} g(t - \tau_l(x))\right] \\
&= \frac{l-x}{\sqrt{2\pi\sigma_2}} \int_0^t g(t-s) s^{-\frac{3}{2}} \exp\left(-\frac{(x-l)^2}{2\sigma_2^2 s}\right) ds.
\end{aligned}$$

3. Let $x > u$ and $\tau_u(x)$ be the first hitting time of u of the process $X^{0,x}$. The stopping time τ_u has the density

$$p_{\tau_u(x)}(t) = \frac{|x-u|}{\sqrt{2\pi\sigma_2} t^{\frac{3}{2}}} \exp\left(-\frac{(x-u)^2}{2\sigma_2^2 t}\right).$$

We have for $t > 0$

$$\begin{aligned}
Q(t, x) &= \mathbb{P}\left(\tau_u(x) \leq t, X_t^{0,x} \in [l, u]\right) + \mathbb{P}\left(\tau_u(x) > t, X_t^{0,x} \in [l, u]\right) \\
&= \mathbb{E}\left[\mathbb{1}_{\{\tau_u(x) \leq t\}} g(t - \tau_u(x))\right] \\
&= \frac{x-u}{\sqrt{2\pi\sigma_2}} \int_0^t g(t-s) s^{-\frac{3}{2}} \exp\left(-\frac{(x-u)^2}{2\sigma_2^2 s}\right) ds.
\end{aligned}$$

Finally, note that the equations for Q shown above also extend to $t = 0$. □

Lemma 4.2 implies that it enough to study the function g since we can represent Q via (19). Moreover, we see that $\mathcal{L}[g] = V(l, \cdot)$ by Corollary 4.1. Therefore, we can characterize g by the inverse Laplace transform of $V(l, \cdot)$. In order to identify g , we introduce $D := \mathbb{C} \setminus (-\infty, 0]$ and define the function

$$F(z) := \frac{1}{z \frac{\sigma_1}{\sigma_2} \coth\left(\frac{u-l}{\sqrt{2}\sigma_1} \sqrt{z}\right) + 1}, \quad z \in D.$$

Since the complex square root is not uniquely determined, we define

$$\sqrt{z} = \sqrt{x+iy} := \sqrt{\frac{\sqrt{x^2+y^2}+x}{2}} + i \cdot \operatorname{sgn}^+(y) \sqrt{\frac{\sqrt{x^2+y^2}-x}{2}}, \quad z = x+iy \in \mathbb{C}, \quad (21)$$

where $\operatorname{sgn}^+(y) := \mathbb{1}_{[0, \infty)}(y) - \mathbb{1}_{(-\infty, 0)}(y)$. From now on, we always understand \sqrt{z} in the sense of (21).

Observe that $F(\lambda) = V(l, \lambda)$, $\lambda > 0$. Hence, F is an extension of $V(l, \cdot)$ to the complex domain D . We emphasize that F is well-defined and holomorphic on the domain D (see Lemma A.1). Recall that the function \hat{g} , defined in (3), is given by

$$\hat{g}(t) = \frac{1}{\pi} \int_0^\infty \frac{e^{-st}}{s} \frac{1}{\frac{\sigma_1}{\sigma_2} \cot\left(\frac{u-l}{\sqrt{2}\sigma_1} \sqrt{s}\right) + \frac{\sigma_2}{\sigma_1} \tan\left(\frac{u-l}{\sqrt{2}\sigma_1} \sqrt{s}\right)} ds, \quad t > 0. \quad (22)$$

We set

$$\Gamma(z) := zF(z) - \frac{\sigma_2}{\sigma_1 + \sigma_2}. \quad (23)$$

Now, we can show the following:

Proposition 4.4. *We have $\mathcal{L}[g] = \mathcal{L}[\hat{g}] = F$, and $g(t) = \hat{g}(t)$ for almost every $t > 0$. In addition, $\hat{g} \in \mathcal{C}^1((0, \infty))$ with derivative given by*

$$\hat{g}'(t) = -\frac{1}{\pi} \int_0^\infty e^{-st} \frac{1}{\frac{\sigma_1}{\sigma_2} \cot\left(\frac{u-l}{2\sigma_1} \sqrt{2s}\right) + \frac{\sigma_2}{\sigma_1} \tan\left(\frac{u-l}{2\sigma_1} \sqrt{2s}\right)} ds, \quad (24)$$

The Laplace transform of \hat{g}' is given by Γ , i.e. $\mathcal{L}[\hat{g}'](\lambda) = \Gamma(\lambda) = \lambda \mathcal{L}[\hat{g}](\lambda) - \frac{\sigma_2}{\sigma_1 + \sigma_2}$, $\lambda > 0$. Moreover, $\hat{g}(0+) = \lim_{t \downarrow 0} \hat{g}(t) = \frac{\sigma_2}{\sigma_1 + \sigma_2}$.

Remark 4.5.

(a) We have chosen the constant $\frac{\sigma_2}{\sigma_1 + \sigma_2}$ in (23) since

$$\lim_{\lambda \rightarrow \infty} \lambda F(\lambda) = \frac{\sigma_2}{\sigma_1 + \sigma_2},$$

motivated by the identity $g(0+) = \lim_{\lambda \rightarrow \infty} \lambda F(\lambda)$, which holds true if the limit exists (see e.g. Theorem 33.5 in [3]).

(b) $\hat{g}(0+) = \frac{\sigma_2}{\sigma_1 + \sigma_2}$ implies that $\lim_{t \downarrow 0} \mathbb{P}(X_t^l \in [l, u]) = \frac{\sigma_2}{\sigma_1 + \sigma_2}$.

(c) We can rewrite the term in the integrand of (24) as follows:

$$\begin{aligned} \frac{1}{\frac{\sigma_1}{\sigma_2} \cot\left(\frac{u-l}{2\sigma_1} \sqrt{2s}\right) + \frac{\sigma_2}{\sigma_1} \tan\left(\frac{u-l}{2\sigma_1} \sqrt{2s}\right)} &= \frac{\frac{1}{2} \sin\left(\frac{u-l}{\sigma_1} \sqrt{2s}\right)}{\frac{\sigma_1}{\sigma_2} \cos^2\left(\frac{u-l}{2\sigma_1} \sqrt{2s}\right) + \frac{\sigma_2}{\sigma_1} \sin^2\left(\frac{u-l}{2\sigma_1} \sqrt{2s}\right)} \\ &= \frac{\frac{1}{2} \sin\left(\frac{u-l}{\sigma_1} \sqrt{2s}\right)}{\frac{\sigma_1}{\sigma_2} + \frac{\sigma_2 - \sigma_1^2}{\sigma_1 \sigma_2} \sin^2\left(\frac{u-l}{2\sigma_1} \sqrt{2s}\right)}, \quad s \in (0, \infty). \end{aligned}$$

Proof of Proposition 4.4. Note that $\hat{g} \in \mathcal{C}^1((0, \infty))$ follows directly from the definition in (22) and (24) follows from differentiation. Moreover, according to Lemma A.2 there exists a continuous function γ , given by (39) in the Appendix below, such that $\mathcal{L}[\gamma] = \Gamma$. We want to show that $\hat{g}' = \gamma$. Theorem 27.1 in [3] and Lemma A.1 imply that for $b > 0$

$$\begin{aligned} \int_0^t \gamma(s) ds &= \lim_{r \rightarrow \infty} \frac{1}{2\pi} \int_{-r}^r e^{b+is} \frac{\Gamma(b+is)}{b+is} ds \\ &= \lim_{r \rightarrow \infty} \frac{1}{2\pi} \int_{-r}^r e^{b+is} F(b+is) ds - \lim_{r \rightarrow \infty} \frac{1}{2\pi} \int_{-r}^r e^{b+is} \frac{\sigma_2}{\sigma_1 + \sigma_2} \frac{1}{b+is} ds \\ &= \hat{g}(t) - \frac{\sigma_2}{\sigma_1 + \sigma_2}, \quad t > 0. \end{aligned}$$

Here we have used the fact that $\mathcal{L}\left[\frac{\sigma_2}{\sigma_1 + \sigma_2}\right](\lambda) = \frac{\sigma_2}{\sigma_1 + \sigma_2} \frac{1}{\lambda}$, $\lambda > 0$, and Theorem 24.4 in [3] to determine the second integral in the second line. Hence,

$$\hat{g}(t) = \frac{\sigma_2}{\sigma_1 + \sigma_2} + \int_0^t \gamma(s) ds.$$

We observe that $\hat{g}(0+) = \frac{\sigma_2}{\sigma_1 + \sigma_2}$, $\hat{g}'(t) = \gamma(t)$, $t > 0$, and $\mathcal{L}[\hat{g}'] = \Gamma$. Now, since $\mathcal{L}[\hat{g}'](\lambda)$ exists for $\lambda > 0$ also $\mathcal{L}[\hat{g}](\lambda)$ exists for $\lambda > 0$ and

$$\mathcal{L}[\hat{g}](\lambda) = \frac{1}{\lambda} \mathcal{L}[\hat{g}'](\lambda) + \frac{\sigma_2}{\sigma_1 + \sigma_2} \frac{1}{\lambda} = \frac{1}{\lambda} \Gamma(\lambda) + \frac{\sigma_2}{\sigma_1 + \sigma_2} \frac{1}{\lambda} = F(\lambda), \quad \lambda > 0,$$

(see e.g. Theorem 8.1 in [3]). Finally, we obtain that $g = \hat{g}$, a.e., since both function have the same Laplace transform (see e.g. Theorem 5.4 in [3]). \square

Proposition 4.4 only yields a formula for g for almost all $t > 0$. The reason for this is that functions with equal Laplace transform only coincide up to null sets. Since we do not know a priori that g is continuous, we work for simplicity with the version \hat{g} of g that is equal to the right-hand side of (22) for all $t > 0$. Additionally, we introduce a version \hat{Q} of Q that makes a definition of a candidate for the value function of our original control problem (6) possible. With this candidate we perform a verification in the proof of Theorem 2.1. For $(t, x) \in (0, \infty) \times \mathbb{R}$ we define the function \hat{Q} by

$$\hat{Q}(t, x) := \begin{cases} \frac{l-x}{\sqrt{2\pi}\sigma_2} \int_0^t \hat{g}(t-s) s^{-\frac{3}{2}} \exp\left(-\frac{(x-l)^2}{2\sigma_2^2 s}\right) ds, & x < l, \\ 1 + \int_0^t (\hat{g}(t-s) - 1) \mathcal{L}^{-1} \left[\frac{\cosh\left(\frac{1}{2\sigma_1}(u+l-2x)\sqrt{2\cdot}\right)}{\cosh\left(\frac{1}{2\sigma_1}(u-l)\sqrt{2\cdot}\right)} \right] (s) ds, & x \in (l, u), \\ \frac{x-u}{\sqrt{2\pi}\sigma_2} \int_0^t \hat{g}(t-s) s^{-\frac{3}{2}} \exp\left(-\frac{(x-u)^2}{2\sigma_2^2 s}\right) ds, & x > u, \\ \hat{g}(t), & x = l, u, \end{cases} \quad (25)$$

and we set $\hat{Q}(0, x) := \mathbb{1}_{[l, u]}(x)$. We have the following:

Lemma 4.6. *The function \hat{Q} has the following properties:*

- (a) $\hat{Q} \in \mathcal{C}^{1,2}((0, \infty) \times \mathbb{R} \setminus \{l, u\}) \cap \mathcal{C}^{0,1}((0, \infty) \times \mathbb{R})$.
- (b) $\hat{Q}(t, \cdot)$ is symmetric in $x = \frac{u+l}{2}$.

Proof. (a) Follows from Lemma A.4 in the Appendix below.

(b) Follows from the symmetry of Q and the definition. \square

We can turn to the proof of the main result of this paper, which is presented in the next section.

5 Proof of the main result

In this section we first prove, via a classical verification, Theorem 2.1. We then prove Theorem 1.1.

Note that the HJB equation of the control problem (6) is given by

$$\partial_t v(t, x) - \mathbb{1}_{[l, u]}(x) - \sup_{b \in [\sigma_1, \sigma_2]} \frac{b^2}{2} \partial_{xx} v(t, x) = 0, \quad v(0, x) = 0. \quad (26)$$

Proof of Theorem 2.1. 1. Let $w(t, x) := \int_0^t \hat{Q}(s, x) ds$. We show that w solves the HJB equation (26). Since $\mathcal{L}[\hat{Q}(\cdot, x)]$ exists on $(0, \infty)$ we know by Theorem 8.1 in [3] that also the Laplace transform of w exists and that

$$\mathcal{L}[w(\cdot, x)](\lambda) = \frac{1}{\lambda} \mathcal{L}[\hat{Q}(\cdot, x)](\lambda), \quad \lambda > 0.$$

Moreover, $\mathcal{L}[\hat{Q}(\cdot, x)](\lambda) = V(x, \lambda)$ and V satisfies (13), (14) and (15). Therefore, by multiplying (14) and (15) with $\frac{1}{\lambda}$ we see that the Laplace transform of w solves the equations

$$\lambda \mathcal{L}[w(\cdot, x)](\lambda) - \frac{1}{\lambda} - \frac{\sigma_1^2}{2} \partial_{xx} \mathcal{L}[w(\cdot, x)](\lambda) = 0, \quad x \in (l, u), \quad (27)$$

$$\lambda \mathcal{L}[w(\cdot, x)](\lambda) - \frac{\sigma_2^2}{2} \partial_{xx} \mathcal{L}[w(\cdot, x)](\lambda) = 0, \quad x \notin [l, u]. \quad (28)$$

We have that $\mathcal{L}[\partial_t w(\cdot, x)](\lambda) = \lambda \mathcal{L}[w(\cdot, x)](\lambda)$ and $\mathcal{L}[\partial_{xx} w(\cdot, x)](\lambda) = \partial_{xx} \mathcal{L}[w(\cdot, x)](\lambda)$ for all $\lambda > 0$. Consequently, the injectivity of the Laplace transform implies that w satisfies the equations

$$\begin{aligned} \partial_t w(t, x) - 1 - \frac{\sigma_1^2}{2} \partial_{xx} w(t, x) &= 0, \quad x \in (l, u), \\ \partial_t w(t, x) - \frac{\sigma_2^2}{2} \partial_{xx} w(t, x) &= 0, \quad x \notin [l, u]. \end{aligned} \quad (29)$$

for all $(t, x) \in (0, \infty) \times \mathbb{R}$. Note that the injectivity of the Laplace transform only implies that (29) is satisfied for almost all $t > 0$, but the continuity of $\partial_t w$ and $\partial_{xx} w$ in t implies that (29) holds true for all $t > 0$.

Now, we observe that $\partial_t w(t, x) = \hat{Q}(t, x) \in [0, 1]$ for all $(t, x) \in (0, \infty) \times \mathbb{R}$. Hence, (29) implies that $w(t, \cdot)$ is concave on $[l, u]$, and convex on $\mathbb{R} \setminus [l, u]$ for all $t > 0$. As a direct consequence we obtain that w solves the HJB equation (26).

2. We show that $w = v$. Note that we know by the definition of w that

$$w(t, x) = \int_0^t \mathbb{P}(X_s^{x, \hat{\alpha}} \in [l, u]) ds = J(t, x, \hat{\alpha}) \leq v(t, x), \quad (t, x) \in (0, \infty) \times \mathbb{R},$$

where $X^{x, \hat{\alpha}}$ is the solution of (7) controlled by the feedback control $\hat{\alpha}_s = \hat{a}(X_s^{x, \hat{\alpha}})$ and starting at time 0 in x . Hence, it suffices to show that $w(t, x) \geq v(t, x)$. Let $(t, x) \in (0, \infty) \times \mathbb{R}$ and $\alpha \in \mathcal{A}$ be an arbitrary control. We denote by $X^{x, \alpha}$ the process governed by (1) and controlled by α . We can apply Itô's formula to $(s, x) \mapsto w(t-s, x)$ between 0 and t and obtain after taking expectations and localizing the terms

$$0 = w(t, x) + \mathbb{E} \left[\int_0^t \left(-\partial_t w(t-s, X_s^{x, \alpha}) + \frac{\alpha_s^2}{2} \partial_{xx} w(t-s, X_s^{x, \alpha}) \right) ds \right]. \quad (30)$$

The application of Itô's formula is possible, because $w \in \mathcal{C}^{1,2}((0, \infty) \times \mathbb{R} \setminus \{l, u\}) \cap \mathcal{C}^{1,1}((0, \infty) \times \mathbb{R})$ and $\partial_x w(t, \cdot)$ is absolutely continuous for all $t > 0$ (see e.g. Section 3.7 in [4]). Since w solves (26), and $w(t, \cdot)$ is concave on $[l, u]$ and convex otherwise, we can estimate the integrand on the right-hand side of (30) from above by $-\mathbb{1}_{[l, u]}(X_s^{x, \alpha})$. It follows that

$$0 \leq w(t, x) - \int_0^t \mathbb{P}(X_s^{x, \alpha} \in [l, u]) ds.$$

Since the choice of α was arbitrary it follows that $v(t, x) \leq w(t, x)$. Finally, $w = v$ and $\hat{\alpha}$ is an optimal control. \square

Proof of Theorem 1.1. From the proof of Theorem 2.1 we know that $v(t, x) = \int_0^t \hat{Q}(s, x) ds$. Now from Equation (20) and the definition of \hat{Q} in (25) we obtain the occupation time bound given in (4). \square

6 Limiting cases

In this section we study the limiting cases $u \rightarrow \infty$ and $l \rightarrow -\infty$. Note that it suffices to consider the case $u \rightarrow \infty$, since the other case can be derived from it. then the control problem reformulates to

$$v(t, x) = \sup_{\alpha \in \mathcal{A}} \int_0^t \mathbb{P}(X_s^{x, \alpha} \geq l) ds, \quad (31)$$

and the HJB equation is given by

$$\partial_t v(t, x) - \mathbb{1}_{[l, \infty)}(x) - \sup_{b \in [\sigma_1, \sigma_2]} \frac{b^2}{2} \partial_{xx} v(t, x) = 0, \quad v(0, x) = 0. \quad (32)$$

As in the previous sections we consider in the beginning the infinite time horizon problem

$$V(x) = \sup_{\alpha \in \mathcal{A}} \int_0^\infty e^{-\lambda t} \mathbb{P}(X_t^{x, \alpha} \geq l) dt,$$

in order to derive a solution to the original problem (31). For the infinite time horizon control problem the HJB equation is given by

$$\lambda V(x) - \mathbb{1}_{[l, \infty)}(x) - \sup_{b \in [\sigma_1, \sigma_2]} \frac{b^2}{2} V''(x) = 0.$$

One can solve the control problem by performing a verification with the function, given by the limit of (16) as $u \rightarrow \infty$. Another way is to solve the HJB equation as in Section 3, by assuming that V is convex on $(-\infty, l)$ and concave otherwise, and show by verification that the solution equals the value function. In both cases we obtain that

$$V(x) = \begin{cases} \frac{\sigma_2}{\sigma_1 + \sigma_2} \frac{1}{\lambda} e^{\frac{\sqrt{2\lambda}}{\sigma_2}(x-l)}, & x < l, \\ \frac{1}{\lambda} - \frac{1}{\lambda} \frac{\sigma_1}{\sigma_1 + \sigma_2} e^{-\frac{\sqrt{2\lambda}}{\sigma_1}(x-l)}, & x \geq l. \end{cases}$$

Moreover, the optimal control is given by the feedback function $b(x) := \sigma_1 \mathbb{1}_{[l, \infty)}(x) + \sigma_2 \mathbb{1}_{(-\infty, l)}(x)$. Now, to solve our original problem (31) we observe that the inverse Laplace transform of V is given by

$$\hat{Q}(t, x) := \mathcal{L}^{-1}[V(x)](t) = \begin{cases} \frac{2\sigma_2}{\sigma_1 + \sigma_2} \left(1 - \Phi\left(\frac{l-x}{\sigma_2\sqrt{t}}\right)\right), & x < l, \\ \frac{2\sigma_1}{\sigma_1 + \sigma_2} \Phi\left(\frac{x-l}{\sigma_1\sqrt{t}}\right), & x \geq l. \end{cases}$$

By applying standard result for Laplace transforms we see that w , given by $w(t, x) := \int_0^t \hat{Q}(s, x) ds$, solves the HJB equation (32). Standard verification arguments imply that $v = w$ and that the optimal control is given by the feedback function b .

We remark that the solution in the unbounded case can also be derived from [6] (see in particular Remark 8 in [6]).

A Appendix

A.1 Auxiliary results

Lemma A.1. (a) For all $z \in D$ we have

$$|F(z)| \leq \frac{1}{|z|}.$$

(b) F is holomorphic on $D := \mathbb{C} \setminus (-\infty, 0]$.

(c) For any $b > 0$ it holds

$$\lim_{r \rightarrow \infty} \int_{-r}^r F(b + is) e^{(b+is)t} ds = 2i \int_0^\infty \frac{e^{-xt}}{x} \frac{1}{\frac{\sigma_1}{\sigma_2} \cot\left(\frac{u-l}{\sqrt{2}\sigma_1} \sqrt{x}\right) + \frac{\sigma_2}{\sigma_1} \tan\left(\frac{u-l}{\sqrt{2}\sigma_1} \sqrt{x}\right)} dx.$$

In particular, the limit on the left-hand side exists and does not depend on the particular choice of $b > 0$. Moreover, we can pass to the limit $b \downarrow 0$ and obtain

$$\lim_{r \rightarrow \infty} \int_{-r}^r F(is) e^{ist} ds = 2i \int_0^\infty \frac{e^{-xt}}{x} \frac{1}{\frac{\sigma_1}{\sigma_2} \cot\left(\frac{u-l}{\sqrt{2}\sigma_1} \sqrt{x}\right) + \frac{\sigma_2}{\sigma_1} \tan\left(\frac{u-l}{\sqrt{2}\sigma_1} \sqrt{x}\right)} dx$$

Proof. (a) Recall that for all $x, y \in \mathbb{R}$

$$\sqrt{x + iy} = \sqrt{\frac{\sqrt{x^2 + y^2} + x}{2}} + i \cdot \operatorname{sgn}^+(y) \sqrt{\frac{\sqrt{x^2 + y^2} - x}{2}}, \quad (33)$$

see (21). One can write the complex hyperbolic cotangent as follows:

$$\coth(x + iy) = \frac{\sinh(2x)}{\cosh(2x) - \cos(2y)} + i \frac{-\sin(2y)}{\cosh(2x) - \cos(2y)}, \quad (34)$$

for any $x, y \in \mathbb{R}$ such that \coth is defined. This yields for $z \in \mathbb{C}$ and $x + iy := \frac{u-l}{\sqrt{2}\sigma_1} \sqrt{z}$

$$\begin{aligned} & \left| \frac{\sigma_1}{\sigma_2} \coth\left(\frac{u-l}{\sqrt{2}\sigma_1} \sqrt{z}\right) + 1 \right|^2 \\ &= \left(1 + \frac{\sigma_1}{\sigma_2} \frac{\sinh(2x)}{\cosh(2x) - \cos(2y)} \right)^2 + \left(-\frac{\sigma_1}{\sigma_2} \frac{\sin(2y)}{\cosh(2x) - \cos(2y)} \right)^2 \end{aligned} \quad (35)$$

$$\geq 1 + \left(-\frac{\sigma_1}{\sigma_2} \frac{\sin(2y)}{\cosh(2x) - \cos(2y)} \right)^2 \geq 1, \quad (36)$$

where we have used that $x = \frac{u-l}{\sqrt{2}\sigma_1} \operatorname{Re}(\sqrt{z}) > 0$. We emphasize that the inequalities in (36) extend to the case where $x = 0$ and $y = ik\pi$, $k \in \mathbb{Z}$, because $\coth(x + iy)$ has a pole in those points implying that $\infty \geq 1$. It follows that

$$|F(z)| = \frac{1}{|z|} \frac{1}{\left| \frac{\sigma_1}{\sigma_2} \coth\left(\frac{u-l}{\sqrt{2}\sigma_1} \sqrt{z}\right) + 1 \right|} \leq \frac{1}{|z|}, \quad z \in \mathbb{C}. \quad (37)$$

(b) The complex hyperbolic cotangent function \coth is defined and holomorphic on $\mathbb{C} \setminus \{ik\pi : k \in \mathbb{Z}\}$. Moreover, (33) implies that for all $z \in D$ we have $\operatorname{Re}(\sqrt{z}) > 0$ and $\sqrt{\cdot}$ is holomorphic on D . Combining these facts with (36) yields that F is holomorphic on D by the chain rule.

(c) Let $b > 0$, $\varepsilon > 0$ sufficiently small and $r > \varepsilon$. Fix $t > 0$. By Cauchy's theorem we have that the integral over the contour shown in figure 1 below is equal to zero, i.e.

$$\int_{-r}^r F(b + is) e^{(b+is)t} ds = - \sum_{i=1}^7 \int_{\gamma_i(r, \varepsilon)} F(z) e^{zt} dz.$$

The integral over $\gamma_1, \gamma_2, \gamma_6$ and γ_7 converges to zero as $r \rightarrow \infty$: One can bound $|F(z)|$ by $\frac{1}{r}$ for $z \in \operatorname{Ran}(\gamma_i)$, see (37). We have e.g.

$$\left| \int_{\gamma_1} F(z) e^{zt} dz \right| = \left| \int_0^{b+r} F(b - s + ir) e^{(b-s+ir)t} ds \right| \leq \frac{e^b}{r} \int_0^{b+r} e^{-s} ds = \frac{e^b}{r} (1 - e^{-(b+r)}) \xrightarrow{r \rightarrow \infty} 0.$$

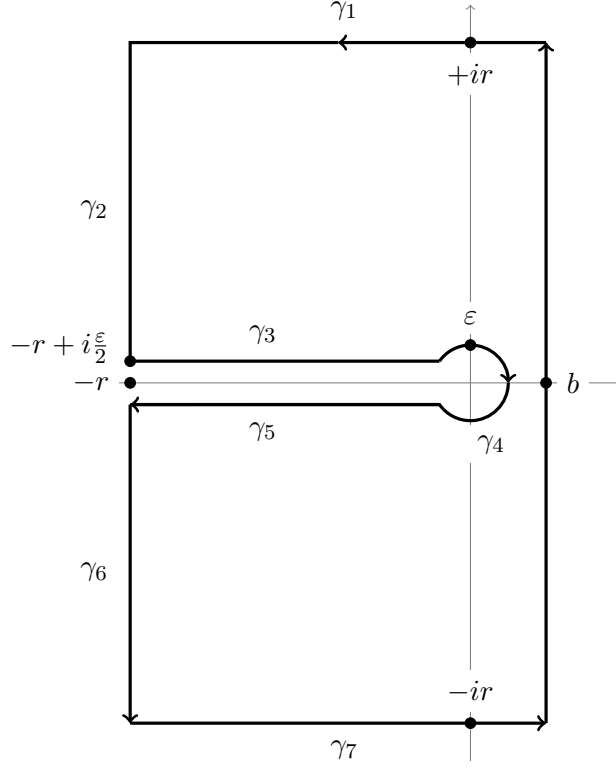

Figure 1: Contour for Cauchy's theorem

The contour integrals over $\gamma_2, \gamma_6, \gamma_7$ can be estimated in the same way. That implies for $i = 1, 2, 6, 7$

$$\lim_{r \rightarrow \infty} \int_{\gamma_i} F(z) e^{zt} dz = 0.$$

Contour integral over γ_4 : We have that

$$\left| \int_{\gamma_4} F(z) e^{zt} dz \right| \leq \left(\max_{z \in \text{Ran}(\gamma_4)} |F(z) e^{zt}| \right) (\text{length of } \gamma_4) = \frac{2\pi\epsilon}{\epsilon} \max_{|z|=\epsilon} \left(\frac{1}{\left| \frac{\sigma_1}{\sigma_2} \coth \left(\frac{u-l}{\sqrt{2}\sigma_1} \sqrt{z} \right) + 1 \right|} \right).$$

Using (33) we see that for $z = x + iy \in \mathbb{C}, |z| = \epsilon$,

$$\sqrt{z} = \sqrt{\frac{\sqrt{x^2 + y^2} + x}{2}} + i \cdot \text{sgn}^+(y) \sqrt{\frac{\sqrt{x^2 + y^2} - x}{2}} = \frac{1}{\sqrt{2}} (\sqrt{\epsilon + x} + i \cdot \text{sgn}^+(y) \sqrt{\epsilon - x}),$$

and thus with (35) and L'Hôpital's rule

$$\begin{aligned} \frac{1}{\left| \frac{\sigma_1}{\sigma_2} \coth \left(\frac{u-l}{\sqrt{2}\sigma_1} \sqrt{z} \right) + 1 \right|} &\leq \frac{\sigma_2}{\sigma_1} \frac{\cosh \left(\frac{u-l}{\sigma_1} \sqrt{\epsilon + x} \right) - \cos \left(\frac{u-l}{\sigma_1} \sqrt{\epsilon - x} \right)}{\sinh \left(\frac{u-l}{\sigma_1} \sqrt{\epsilon + x} \right)} \\ &\leq \frac{\cosh \left(\frac{u-l}{\sigma_1} \sqrt{\epsilon} \right) - \cos \left(\frac{u-l}{\sigma_1} \sqrt{\epsilon} \right)}{\sinh \left(\frac{u-l}{\sigma_1} \sqrt{\epsilon} \right)} \xrightarrow{\epsilon \downarrow 0} 0. \end{aligned}$$

From the first to the second line we have used that the term is monotonically decreasing in x . To sum up, the contour integral over γ_4 converges to zero as $\epsilon \downarrow 0$.

Contour integral over γ_3 : One can parametrize γ_3 e.g. by $\gamma_3(s) = -s + i\frac{\varepsilon}{2}$, $s \in \left[\frac{\sqrt{3}}{2}\varepsilon, r\right]$. We have

$$\int_{\gamma_3} F(z)e^{zt} dz = - \int_{\frac{\sqrt{3}}{2}\varepsilon}^r F\left(-s + i\frac{\varepsilon}{2}\right) e^{(-s+i\frac{\varepsilon}{2})t} ds$$

First of all, we want to take the limit $\varepsilon \downarrow 0$. Observe that with $C := \frac{u-l}{2\sigma_1}$ and

$$x := C\sqrt{\sqrt{s^2 + \frac{\varepsilon^2}{4}} - s}, \quad y := C\sqrt{\sqrt{s^2 + \frac{\varepsilon^2}{4}} + s}$$

we obtain by using (34) that

$$\begin{aligned} \left| \coth\left(\frac{u-l}{\sqrt{2}\sigma_1}\sqrt{-s + i\frac{\varepsilon}{2}}\right) + \frac{\sigma_2}{\sigma_1} \right|^2 &= \left| \coth(x + iy) + \frac{\sigma_2}{\sigma_1} \right|^2 \\ &= \left(\frac{\sigma_2}{\sigma_1} + \frac{\sinh(2x)}{\cosh(2x) - \cos(2y)} \right)^2 + \left(\frac{\sin(2y)}{\cosh(2x) - \cos(2y)} \right)^2 \\ &\geq \left(\frac{\sigma_2}{\sigma_1} \right)^2 + \left(\frac{\sin(2y)}{1 - \cos(2y)} \right)^2 \geq 1 + \left(\frac{\sin(2y)}{1 - \cos(2y)} \right)^2 \\ &= 1 + \cot^2(y) = \frac{1}{\sin^2(y)} = \frac{1}{\sin^2\left(C\sqrt{\sqrt{s^2 + \frac{\varepsilon^2}{4}} + s}\right)}, \quad s > 0. \end{aligned}$$

Hence, we have

$$\begin{aligned} \mathbf{1}_{\left[\frac{\sqrt{3}}{2}\varepsilon, 1\right]}(s) \left| F\left(-s + i\frac{\varepsilon}{2}\right) \right| &\leq \mathbf{1}_{\left[\frac{\sqrt{3}}{2}\varepsilon, 1\right]}(s) \frac{1}{s} \left| \sin\left(C\sqrt{\sqrt{s^2 + \frac{\varepsilon^2}{4}} + s}\right) \right| \\ &\leq \mathbf{1}_{\left[\frac{\sqrt{3}}{2}\varepsilon, 1\right]}(s) \frac{|\sin(C\sqrt{2s + \frac{\varepsilon}{2}})|}{s} \leq \frac{|\sin(C\sqrt{3s})|}{s}, \quad s > 0. \end{aligned}$$

Note that the function $\frac{1}{s}|\sin(C\sqrt{3s})|$ is absolutely integrable on $[0, r]$. Dominated convergence with domination by this function yields

$$\lim_{\varepsilon \downarrow 0} \int_{\frac{\sqrt{3}}{2}\varepsilon}^r F\left(-s + i\frac{\varepsilon}{2}\right) e^{(-s+i\frac{\varepsilon}{2})t} ds = \int_0^r F(-s)e^{-st} ds.$$

In particular, the integral on the right-hand sides exists and converges absolutely. Now, we consider the limit $r \rightarrow \infty$: Since $|F(-s)| \leq 1$ according to (35) the integral $\int_1^\infty F(-s)e^{-st} ds$ converges absolutely. Consequently, also the integral $\int_0^\infty F(-s)e^{-st} ds$ converges absolutely and

$$\begin{aligned} \lim_{r \rightarrow \infty} \lim_{\varepsilon \downarrow 0} \int_{\gamma_3} F(z)e^{zt} dz &= \int_0^\infty F(-s)e^{-st} ds \\ &= - \int_0^\infty e^{-st} \frac{1}{s} \frac{1}{\frac{\sigma_1}{\sigma_2} \coth\left(i\frac{u-l}{\sqrt{2}\sigma_1}\sqrt{s}\right) + 1} ds \\ &= - \int_0^\infty e^{-st} \frac{1}{s} \frac{1}{-i\frac{\sigma_1}{\sigma_2} \cot\left(\frac{u-l}{\sqrt{2}\sigma_1}\sqrt{s}\right) + 1} ds. \end{aligned} \tag{38}$$

In the same way one can show that the contour integral over γ_5 converges. We obtain

$$\lim_{r \rightarrow \infty} \lim_{\varepsilon \downarrow 0} \int_{\gamma_5} F(z)e^{zt} dz = \lim_{r \rightarrow \infty} \lim_{\varepsilon \downarrow 0} \int_{\frac{\sqrt{3}}{2}\varepsilon}^r F\left(-s - i\frac{\varepsilon}{2}\right) e^{(-s-i\frac{\varepsilon}{2})t} ds$$

$$\begin{aligned}
&= \int_0^\infty \frac{e^{-st}}{s} \frac{1}{\frac{\sigma_1}{\sigma_2} \coth\left(\frac{u-l}{\sqrt{2}\sigma_1}(-i)\sqrt{s}\right) + 1} ds \\
&= \int_0^\infty \frac{e^{-st}}{s} \frac{1}{i\frac{\sigma_1}{\sigma_2} \cot\left(\frac{u-l}{\sqrt{2}\sigma_1}\sqrt{s}\right) + 1} ds.
\end{aligned}$$

In addition, the integral on the right-hand side converges absolutely. Summing up, we obtain that

$$\begin{aligned}
&\lim_{r \rightarrow \infty} \int_{-r}^r F(b+is)e^{(b+is)t} ds \\
&= \int_0^\infty e^{-st} \frac{1}{s} \frac{1}{-i\frac{\sigma_1}{\sigma_2} \cot\left(\frac{u-l}{\sqrt{2}\sigma_1}\sqrt{s}\right) + 1} ds - \int_0^\infty \frac{e^{-st}}{s} \frac{1}{i\frac{\sigma_1}{\sigma_2} \cot\left(\frac{u-l}{\sqrt{2}\sigma_1}\sqrt{s}\right) + 1} ds \\
&= \int_0^\infty \frac{e^{-st}}{s} \left(\frac{1}{-i\frac{\sigma_1}{\sigma_2} \cot\left(\frac{u-l}{\sqrt{2}\sigma_1}\sqrt{s}\right) + 1} - \frac{1}{i\frac{\sigma_1}{\sigma_2} \cot\left(\frac{u-l}{\sqrt{2}\sigma_1}\sqrt{s}\right) + 1} \right) ds \\
&= \int_0^\infty \frac{e^{-st}}{s} \frac{2i\frac{\sigma_1}{\sigma_2} \cot\left(\frac{u-l}{\sqrt{2}\sigma_1}\sqrt{s}\right)}{\left(\frac{\sigma_1}{\sigma_2} \cot\left(\frac{u-l}{\sqrt{2}\sigma_1}\sqrt{s}\right)\right)^2 - 1} ds \\
&= 2i \int_0^\infty \frac{e^{-st}}{s} \frac{1}{\frac{\sigma_1}{\sigma_2} \cot\left(\frac{u-l}{\sqrt{2}\sigma_1}\sqrt{s}\right) + \frac{\sigma_2}{\sigma_1} \tan\left(\frac{u-l}{\sqrt{2}\sigma_1}\sqrt{s}\right)} ds, \quad t > 0.
\end{aligned}$$

Now, we consider the limit $b \downarrow 0$: Using the arguments above we have that

$$\int_{-r}^r F(b+is)e^{(b+is)t} ds = - \sum_{i=1}^7 \int_{\gamma_i(r,\varepsilon)} F(z)e^{zt} dz.$$

By taking the limit $\varepsilon \downarrow 0$ on the right-hand side we see that only γ_1 and γ_7 depend on the choice of b . Moreover, we can use dominated convergence for the limit $b \downarrow 0$ and obtain

$$\begin{aligned}
\int_{-r}^r F(is)e^{ist} ds &= \int_0^r F(-s+ir)e^{-s+ir} ds - \int_0^r F(s-r-ir)e^{s-r-ir} ds \\
&\quad - \int_{\gamma_2} F(z)e^{zt} dz - \int_{\gamma_6} F(z)e^{zt} dz \\
&\quad + 2i \int_0^r \frac{e^{-st}}{s} \frac{1}{\frac{\sigma_1}{\sigma_2} \cot\left(\frac{u-l}{\sqrt{2}\sigma_1}\sqrt{s}\right) + \frac{\sigma_2}{\sigma_1} \tan\left(\frac{u-l}{\sqrt{2}\sigma_1}\sqrt{s}\right)} ds.
\end{aligned}$$

Taking the limit $r \rightarrow \infty$ yields

$$\lim_{r \rightarrow \infty} \int_{-r}^r F(is)e^{ist} ds = 2i \int_0^\infty \frac{e^{-st}}{s} \frac{1}{\frac{\sigma_1}{\sigma_2} \cot\left(\frac{u-l}{\sqrt{2}\sigma_1}\sqrt{s}\right) + \frac{\sigma_2}{\sigma_1} \tan\left(\frac{u-l}{\sqrt{2}\sigma_1}\sqrt{s}\right)} ds.$$

□

Lemma A.2. *The function Γ , defined in (23), has the following properties:*

- (a) Γ is holomorphic on $\{z \in \mathbb{C} : \operatorname{Re}(z) > 0\}$.

(b) For all $x \geq 0$ we have

$$\int_{-\infty}^{\infty} |\Gamma(x + iy)| dy < \infty,$$

and $\Gamma(z) = \Gamma(x + iy)$ converges to zero as $z = x + iy$ converges two-dimensionally to infinity in every half-plane $x \geq 0$.

(c) Γ can be represented as Laplace transform of a continuous function $\gamma : \mathbb{R} \rightarrow \mathbb{R}$. For all $x > 0$ we have

$$\gamma(t) = \frac{1}{2\pi} \int_{-\infty}^{\infty} \Gamma(x + is) e^{its} ds, \quad t \in \mathbb{R},$$

where the right-hand side does not depend on the particular choice of $x > 0$. In addition, $\gamma(t) = 0$, $t \leq 0$ and

$$\gamma(t) = \frac{1}{2\pi} \int_{-\infty}^{\infty} \Gamma(is) e^{its} ds = \frac{2}{\pi} \int_0^{\infty} \operatorname{Re}(\Gamma(is)) \cos(ts) ds, \quad t > 0. \quad (39)$$

Remark A.3 (cf. [3], chapter 28). We say that a function $f : \mathbb{C} \rightarrow \mathbb{C}$ converges in the half-plane $x \geq x_0$ to zero as $z = x + iy$ converges two-dimensionally to ∞ if for every $\varepsilon > 0$ there exists $R > 0$ such that

$$|f(z)| \leq \varepsilon,$$

for all $z \in \mathbb{C}$ with $\operatorname{Re}(z) \geq x_0, |z| > R$.

Proof. (a) Follows from Lemma A.1 (a).

(b) For the following estimates let $x, y \in \mathbb{R}, x > 0$, be fixed. We want to estimate $|\Gamma(x + iy)|$ in order to show the absolute integrability of $\Gamma(x + i \cdot)$. We denote by r and s the real and imaginary part of $\sqrt{2}(u - l)\sigma_1^{-1}\sqrt{x + iy}$, i.e. $r + is := \sqrt{2}(u - l)\sigma_1^{-1}\sqrt{x + iy}$. In particular,

$$r := \frac{u - l}{\sigma_1} \sqrt{\sqrt{x^2 + y^2} + x}, \quad s := \pm \frac{u - l}{\sigma_1} \sqrt{\sqrt{x^2 + y^2} - x},$$

where the sign of s depends on the sign of y (recall the formula (33)). Using the formula for the complex hyperbolic cotangent (34) we have

$$\begin{aligned} \left| \frac{\sigma_1}{\sigma_2} \coth \left(\frac{u - l}{\sqrt{2}\sigma_1} \sqrt{x + iy} \right) + 1 \right| &= \left| \frac{\sigma_1}{\sigma_2} \coth \left(\frac{r + is}{2} \right) + 1 \right| \\ &\geq 1 + \frac{\sigma_1}{\sigma_2} \frac{\sinh(r)}{\cosh(r) - \cos(s)} \geq 1 + \frac{\sigma_1}{\sigma_2} \frac{\sinh(r)}{\cosh(r)}. \end{aligned}$$

Moreover, we have

$$\begin{aligned} \left| 1 - \coth \left(\frac{u - l}{\sqrt{2}\sigma_1} \sqrt{x + iy} \right) \right|^2 &= \left| 1 - \coth \left(\frac{r + is}{2} \right) \right|^2 \\ &= \left(1 - \frac{\sinh(r)}{\cosh(r) - \cos(s)} \right)^2 + \left(\frac{\sin(s)}{\cosh(r) - \cos(s)} \right)^2 \\ &= \frac{\sinh^2(r) - 2\sinh(r)(\cosh(r) - \cos(s)) + (\cosh(r) - \cos(s))^2 + \sin^2(s)}{(\cosh(r) - \cos(s))^2} \\ &= \frac{(\cosh(r) - \sinh(r))^2 + 2\sinh(r)\cos(s) - 2\cosh(r)\cos(s) + \cos^2(s) + \sin^2(s)}{(\cosh(r) - \cos(s))^2} \\ &= \frac{2 - 2\cos(s)(\cosh(r) - \sinh(r))}{(\cosh(r) - \cos(s))^2} \end{aligned}$$

$$\leq \frac{2}{(\cosh(r) - \cos(s))^2}$$

Combining the estimates above we see that

$$\begin{aligned} |\Gamma(x + iy)| &= \left| \frac{1}{\frac{\sigma_1}{\sigma_2} \coth\left(\frac{u-l}{\sqrt{2}\sigma_1}\sqrt{x+iy}\right) + 1} - \frac{\sigma_2}{\sigma_1 + \sigma_2} \right| \\ &= \left| \frac{1 - \frac{\sigma_2}{\sigma_1 + \sigma_2} \left(\frac{\sigma_1}{\sigma_2} \coth\left(\frac{u-l}{\sqrt{2}\sigma_1}\sqrt{x+iy}\right) + 1\right)}{\frac{\sigma_1}{\sigma_2} \coth\left(\frac{u-l}{\sqrt{2}\sigma_1}\sqrt{x+iy}\right) + 1} \right| \\ &= \frac{\sigma_1}{\sigma_1 + \sigma_2} \frac{\left|1 - \coth\left(\frac{u-l}{\sqrt{2}\sigma_1}\sqrt{x+iy}\right)\right|}{\left|\frac{\sigma_1}{\sigma_2} \coth\left(\frac{u-l}{\sqrt{2}\sigma_1}\sqrt{x+iy}\right) + 1\right|} \\ &\leq \frac{\sigma_1}{\sigma_1 + \sigma_2} \frac{\sqrt{2}}{\cosh(r) - \cos(s)} \left(1 + \frac{\sigma_1}{\sigma_2} \frac{\sinh(r)}{\cosh(r) - \cos(s)}\right)^{-1} \\ &= \frac{\sqrt{2}\sigma_1}{\sigma_1 + \sigma_2} \left(\cosh(r) - \cos(s) + \frac{\sigma_1}{\sigma_2} \sinh(r)\right)^{-1} \\ &\leq \frac{\sqrt{2}\sigma_1}{\sigma_1 + \sigma_2} \left(\frac{\sigma_1}{\sigma_2} \sinh(r)\right)^{-1} \leq \frac{\sqrt{2}\sigma_2}{\sigma_1 + \sigma_2} \frac{1}{\sinh\left(\frac{u-l}{\sigma_1}\sqrt{\sqrt{x^2 + y^2} + x}\right)} \\ &\leq \frac{\sqrt{2}\sigma_2}{\sigma_1 + \sigma_2} \frac{1}{\sinh\left(\frac{u-l}{\sigma_1}\sqrt{|y|}\right)}. \end{aligned}$$

In the last steps we have used that $\cosh(r) - \cos(s) \geq 0$, and that $\sqrt{|y|} \leq \sqrt{\sqrt{x^2 + y^2} + x}$.

Now, we have that

$$\int_0^1 |\Gamma(x + iy)| dy \leq \frac{\sqrt{2}\sigma_2}{\sigma_1 + \sigma_2} \int_0^1 \frac{1}{\sinh\left(\frac{u-l}{\sigma_1}\sqrt{y}\right)} dy = \frac{\sqrt{2}\sigma_2}{\sigma_1 + \sigma_2} \frac{2\sigma_1^2}{(u-l)^2} \int_0^{\frac{u-l}{\sigma_1}} \frac{y}{\sinh(y)} dy < \infty,$$

since $0 \leq y \leq \sinh(y)$ for $y \geq 0$. Moreover,

$$\begin{aligned} \int_1^\infty |\Gamma(x + iy)| dy &\leq \frac{\sqrt{2}\sigma_2}{\sigma_1 + \sigma_2} \int_1^\infty \frac{1}{\sinh\left(\frac{u-l}{\sigma_1}\sqrt{y}\right)} dy = \frac{\sqrt{2}\sigma_2}{\sigma_1 + \sigma_2} \frac{2\sigma_1^2}{(u-l)^2} \int_{\frac{u-l}{\sigma_1}}^\infty \frac{y}{\sinh(y)} dy \\ &\leq \frac{\sqrt{2}\sigma_2}{\sigma_1 + \sigma_2} \frac{2\sigma_1^2}{(u-l)^2} \frac{2}{1 - e^{-2}} \int_{\frac{u-l}{\sigma_1}}^\infty ye^{-y} dy < \infty. \end{aligned}$$

Hence, $\int_0^\infty |\Gamma(x + iy)| dy < \infty$. In exactly the same way one can argue that $\int_{-\infty}^0 |\Gamma(x + iy)| dy < \infty$. We obtain that $\Gamma(x + i \cdot)$ is absolutely integrable for all $x > 0$.

The convergence of $\Gamma(z)$ to zero as z tends two-dimensionally to infinity follows from the estimates above: Let $\varepsilon > 0$. Since $\sinh(a)$ converges to ∞ as $a \rightarrow \infty$, there exists an $R > 0$ such that

$$|\Gamma(z)| = |\Gamma(x + iy)| \leq \frac{\sqrt{2}\sigma_2}{\sigma_1 + \sigma_2} \frac{1}{\sinh\left(\frac{u-l}{\sigma_1}\sqrt{\sqrt{x^2 + y^2} + x}\right)} < \varepsilon,$$

for all $z = x + iy \in \mathbb{C}$ with $|z| = \sqrt{x^2 + y^2} > R$ and $x \geq 0$.

(c) Theorem 28.2 in [3] implies that there exists a continuous $\gamma : \mathbb{R} \rightarrow \mathbb{R}$ such that $\mathcal{L}[\gamma] = \Gamma$ and

$$\gamma(t) = \frac{1}{2\pi} \int_{-\infty}^{\infty} \Gamma(x + is) e^{its} ds, \quad t \in \mathbb{R}, \quad (40)$$

since the points (a) and (b) yield the sufficient conditions. The right-hand side does not depend on the choice of x and $\gamma(t) = 0$, $t \leq 0$. Dominated convergence with domination by

$$\frac{\sqrt{2}\sigma_2}{\sigma_1 + \sigma_2} \frac{1}{\sinh\left(\frac{u-l}{\sigma_1} \sqrt{|y|}\right)}$$

implies that we can take the limit $x \rightarrow 0$ on the right-hand side of (40) and obtain

$$\gamma(t) = \frac{1}{2\pi} \int_{-\infty}^{\infty} \Gamma(is) e^{its} ds, \quad t \in \mathbb{R}.$$

Note that $\Gamma(-is) = \overline{\Gamma(is)}$, $s \in \mathbb{R}$, since $\sqrt{-is} = \overline{\sqrt{is}}$, $s \in \mathbb{R}$, $\coth(\bar{z}) = \overline{\coth(z)}$, $z \in \mathbb{C}$, we have that

$$\begin{aligned} \Gamma(-is) &= \frac{1}{\frac{\sigma_1}{\sigma_2} \coth\left(\frac{u-l}{\sqrt{2}\sigma_1} \sqrt{-is}\right) + 1} - \frac{\sigma_2}{\sigma_1 + \sigma_2} \\ &= \frac{1}{\frac{\sigma_1}{\sigma_2} \coth\left(\frac{u-l}{\sqrt{2}\sigma_1} \sqrt{is}\right) + 1} - \frac{\sigma_2}{\sigma_1 + \sigma_2} = \overline{\Gamma(is)}, \quad s \in \mathbb{R}. \end{aligned}$$

This implies together with the property $\gamma(t) = 0$, $t \leq 0$, that for $t > 0$

$$\begin{aligned} \gamma(t) &= \gamma(t) + \gamma(-t) = \frac{1}{2\pi} \int_{-\infty}^{\infty} \Gamma(is) (e^{its} - e^{-its}) ds = \frac{1}{\pi} \int_{-\infty}^{\infty} \Gamma(is) \cos(ts) ds \\ &= \frac{1}{\pi} \int_0^{\infty} \Gamma(is) \cos(ts) ds + \frac{1}{\pi} \int_{-\infty}^0 \Gamma(is) \cos(ts) ds \\ &= \frac{1}{\pi} \int_0^{\infty} \Gamma(is) \cos(ts) ds + \frac{1}{\pi} \int_0^{\infty} \overline{\Gamma(is)} \cos(ts) ds = \frac{2}{\pi} \int_0^{\infty} \operatorname{Re}(\Gamma(is)) \cos(ts) ds. \end{aligned}$$

□

A.2 Smoothness properties of \hat{Q}

Lemma A.4. $\hat{Q} \in \mathcal{C}^{1,2}((0, \infty) \times \mathbb{R} \setminus \{l, u\}) \cap \mathcal{C}^{0,1}((0, \infty) \times \mathbb{R})$. The derivatives are given by the formulas in the proof.

Proof. 1. **Continuity of \hat{Q} :** \hat{Q} is obviously continuous on $(0, \infty) \times ((-\infty, l) \cup (l, u) \cup (u, \infty))$. We consider the point $x = u$. Let $t > 0$. Then using integration by parts we see that

$$\begin{aligned} \lim_{x \downarrow u} \hat{Q}(t, x) &= \lim_{x \downarrow u} \left(2\hat{g}(t) - 2\hat{g}(0+) \Phi\left(\frac{x-u}{\sigma_2 \sqrt{t}}\right) - \int_0^t 2\hat{g}'(t-s) \Phi\left(\frac{x-u}{\sigma_2 \sqrt{s}}\right) ds \right) \\ &= 2\hat{g}(t) - \hat{g}(0+) - (\hat{g}(t) - \hat{g}(0+)) = \hat{g}(t), \end{aligned}$$

and similarly,

$$\lim_{x \uparrow u} \hat{Q}(t, x) = 1 + \lim_{x \uparrow u} \int_0^t (\hat{g}(t-s) - 1) \frac{u-x}{\sqrt{2\pi}\sigma_1 s^{\frac{3}{2}}} \exp\left(-\frac{(u-x)^2}{2\sigma_1^2 s}\right) ds$$

$$\begin{aligned}
& + \lim_{x \uparrow u} \int_0^t (\hat{g}(t-s) - 1) \sum_{k \neq 0} (-1)^k \frac{u-x+k(u-l)}{\sqrt{2\pi}\sigma_1 s^{\frac{3}{2}}} \exp\left(\frac{(u-x+k(u-l))^2}{2\sigma_1^2 s}\right) ds \\
& = 1 + \lim_{x \uparrow u} \left(2(\hat{g}(t) - 1) - 2(\hat{g}(0+) - 1) \Phi\left(\frac{u-x}{\sigma_1 \sqrt{t}}\right) - \int_0^t 2\hat{g}'(t-s) \Phi\left(\frac{u-x}{\sigma_1 \sqrt{s}}\right) ds \right) \\
& \quad + \int_0^t (\hat{g}(t-s) - 1) \sum_{k \neq 0} (-1)^k \frac{k(u-l)}{\sqrt{2\pi}\sigma_1 s^{\frac{3}{2}}} \exp\left(\frac{(k(u-l))^2}{2\sigma_1^2 s}\right) ds \\
& = \hat{g}(t).
\end{aligned}$$

Hence, $\hat{Q}(t, \cdot)$ is continuous in $x = u$. The symmetry of \hat{Q} implies that $\hat{Q}(t, \cdot)$ is also continuous in $x = l$. Thus, $\hat{Q} \in C^{0,0}((0, \infty) \times \mathbb{R})$.

2. Differentiability w.r.t. t : We know that $\hat{g} \in C^1((0, \infty))$ and therefore also \hat{Q} is continuously differentiable in time, except for the points $x = l, u$, where the derivatives are not continuous. Using Leibniz's integral rule we can calculate the derivative explicitly: For $x < l$ we have

$$\begin{aligned}
\partial_t \hat{Q}(t, x) & = \frac{l-x}{\sqrt{2\pi}\sigma_2} \int_0^t \hat{g}'(t-s) s^{-\frac{3}{2}} \exp\left(-\frac{(x-l)^2}{2s\sigma_2^2}\right) ds \\
& \quad + \frac{l-x}{\sqrt{2\pi}\sigma_2} \hat{g}(0+) t^{-\frac{3}{2}} \exp\left(-\frac{(x-l)^2}{2t\sigma_2^2}\right) \\
& = \frac{l-x}{\sqrt{2\pi}\sigma_2} \int_0^t \hat{g}(t-s) s^{-\frac{7}{2}} \left(\frac{(l-x)^2}{2\sigma_2^2} - \frac{3}{2}s\right) \exp\left(-\frac{(x-l)^2}{2s\sigma_2^2}\right) ds, \quad t > 0.
\end{aligned}$$

For $x \in (l, u)$ we observe that

$$\begin{aligned}
\partial_t \hat{Q}(t, x) & = \sum_{k=-\infty}^{\infty} (-1)^k \int_0^t \hat{g}'(t-s) \frac{u-x+k(u-l)}{\sqrt{2\pi}\sigma_1 s^{\frac{3}{2}}} \exp\left(-\frac{(u-x+k(u-l))^2}{2\sigma_1^2 s}\right) ds \\
& \quad + \sum_{k=-\infty}^{\infty} (-1)^k (\hat{g}(0+) - 1) \frac{u-x+k(u-l)}{\sqrt{2\pi}\sigma_1 t^{\frac{3}{2}}} \exp\left(-\frac{(u-x+k(u-l))^2}{2\sigma_1^2 t}\right) \\
& = \sum_{k=-\infty}^{\infty} (-1)^k \frac{u-x+k(u-l)}{\sqrt{2\pi}\sigma_1} \int_0^t (\hat{g}(t-s) - 1) s^{-\frac{7}{2}} \left(\frac{(u-x+k(u-l))^2}{2\sigma_1^2 s^{\frac{3}{2}}} - \frac{3}{2}s\right) \\
& \quad \cdot \exp\left(-\frac{(u-x+k(u-l))^2}{2\sigma_1^2 s}\right) ds.
\end{aligned}$$

Note also Remark 4.3 for details on the uniform convergence of the series.

The symmetry of \hat{Q} in $\frac{l+u}{2}$ implies that for $x > u$

$$\partial_t \hat{Q}(t, x) = \frac{x-u}{\sqrt{2\pi}\sigma_2} \int_0^t \hat{g}(t-s) s^{-\frac{7}{2}} \left(\frac{(x-u)^2}{2\sigma_2^2} - \frac{3}{2}s\right) \exp\left(-\frac{(x-u)^2}{2s\sigma_2^2}\right) ds, \quad t > 0.$$

For $x = l, u$ we have

$$\partial_t \hat{Q}(t, x) = \hat{g}(t), \quad t > 0.$$

3. Differentiability w.r.t. x : For $x < l$ we have for $t > 0$

$$\partial_x \hat{Q}(t, x) = \frac{1}{\sqrt{2\pi}\sigma_2} \int_0^t \hat{g}(t-s) s^{-\frac{3}{2}} \left(\frac{(l-x)^2}{s\sigma_2^2} - 1\right) \exp\left(-\frac{(x-l)^2}{2s\sigma_2^2}\right) ds, \quad (41)$$

$$\partial_{xx} \hat{Q}(t, x) = \frac{(l-x)^3}{\sqrt{2\pi}\sigma_2^5} \int_0^t \hat{g}(t-s) s^{-\frac{7}{2}} \left(1 - \frac{3s\sigma_2^2}{(l-x)^2}\right) \exp\left(-\frac{(x-l)^2}{2s\sigma_2^2}\right) ds. \quad (42)$$

For $x \in (l, u)$ we have for $t > 0$

$$\begin{aligned} \partial_x \hat{Q}(t, x) = \sum_{k=-\infty}^{\infty} (-1)^k \int_0^t \frac{g(t-s) - 1}{\sqrt{2\pi}\sigma_1 s^{\frac{3}{2}}} \left(\frac{(u-x+k(u-l))^2}{\sigma_1^2 s} - 1 \right) \\ \exp\left(-\frac{(u-x+k(u-l))^2}{2\sigma_1^2 s}\right) ds, \end{aligned} \quad (43)$$

and

$$\begin{aligned} \partial_{xx} \hat{Q}(t, x) = \sum_{k=-\infty}^{\infty} (-1)^k \int_0^t \frac{g(t-s) - 1}{\sqrt{2\pi}} \frac{u-x+k(u-l)}{\sigma_1^3 s^{\frac{5}{2}}} \left(\frac{(u-x+k(u-l))^2}{\sigma_1^2 s} - 3 \right) \\ \cdot \exp\left(-\frac{(u-x+k(u-l))^2}{2\sigma_1^2 s}\right) ds. \end{aligned}$$

For $x > u$ we can again use the symmetry of \hat{Q} and obtain that for $t > 0$

$$\begin{aligned} \partial_x \hat{Q}(t, x) &= \frac{1}{\sqrt{2\pi}\sigma_2} \int_0^t \hat{g}(t-s) s^{-\frac{3}{2}} \left(\frac{(x-u)^2}{2s\sigma_2^2} - 1 \right) \exp\left(-\frac{(x-u)^2}{2s\sigma_2^2}\right) ds, \\ \partial_{xx} \hat{Q}(t, x) &= \frac{(x-u)^3}{\sqrt{2\pi}\sigma_2^5} \int_0^t \hat{g}(t-s) s^{-\frac{7}{2}} \left(1 - \frac{3s\sigma_2^2}{(x-u)^2} \right) \exp\left(-\frac{(x-u)^2}{2s\sigma_2^2}\right) ds. \end{aligned}$$

4. Differentiability of \hat{Q} in $x = l, u$: For $(t, x) \in (0, \infty) \times (-\infty, l)$ we have using (41) and integration by parts

$$\partial_x \hat{Q}(t, x) = \frac{2}{\sqrt{2\pi}\sigma_2} \left(\hat{g}(0+) t^{-\frac{1}{2}} \exp\left(-\frac{(l-x)^2}{2t\sigma_2^2}\right) + \int_0^t \hat{g}'(t-s) s^{-\frac{1}{2}} \exp\left(-\frac{(l-x)^2}{2s\sigma_2^2}\right) ds \right).$$

Thus, taking the limit $x \uparrow l$ yields

$$\lim_{x \uparrow l} \partial_x \hat{Q}(t, x) = \frac{2}{\sqrt{2\pi}\sigma_2} \left(\hat{g}(0+) t^{-\frac{1}{2}} + \int_0^t \hat{g}'(t-s) s^{-\frac{1}{2}} ds \right).$$

and the Laplace transform of the right-hand side is given by

$$\begin{aligned} \mathcal{L} \left[\lim_{x \uparrow l} \partial_x \hat{Q}(\cdot, x) \right] (\lambda) &= \frac{2}{\sqrt{2\pi}\sigma_2} \mathcal{L} \left[(\cdot)^{-\frac{1}{2}} \right] (\lambda) (\hat{g}(0+) + \mathcal{L}[\hat{g}'](\lambda)) \\ &= \frac{2}{\sqrt{2}\sigma_2} \frac{1}{\sqrt{\lambda}} (\hat{g}(0+) + \lambda F(\lambda) - \hat{g}(0+)) \\ &= \frac{1}{\sigma_2} \sqrt{\frac{2}{\lambda}} \lambda F(\lambda) = \frac{1}{\sigma_2} \sqrt{\frac{2}{\lambda}} \frac{1}{\frac{\sigma_1}{\sigma_2} \coth\left(\frac{u-l}{\sqrt{2}\sigma_1} \sqrt{\lambda}\right) + 1}. \end{aligned}$$

Now, we consider the case $x \in (l, u)$: We can apply the integration by parts formula to (43) and obtain for $(t, x) \in (0, \infty) \times (l, u)$

$$\begin{aligned} \partial_x \hat{Q}(t, x) &= 2 \sum_{k=-\infty}^{\infty} (-1)^k (\hat{g}(0+) - 1) \frac{t^{-\frac{1}{2}}}{\sqrt{2\pi}\sigma_1} \exp\left(-\frac{(u-x+k(u-l))^2}{2t\sigma_1^2}\right) \\ &\quad + 2 \sum_{k=-\infty}^{\infty} (-1)^k \int_0^t \hat{g}'(t-s) \frac{s^{-\frac{1}{2}}}{\sqrt{2\pi}\sigma_1} \exp\left(-\frac{(u-x+k(u-l))^2}{2s\sigma_1^2}\right) ds. \end{aligned}$$

We observe that if $x \downarrow l$ we have

$$\begin{aligned}
\lim_{x \downarrow l} \partial_x \hat{Q}(t, x) &= 2 \sum_{k=-\infty}^{\infty} (-1)^k (\hat{g}(0+) - 1) \frac{t^{-\frac{1}{2}}}{\sqrt{2\pi\sigma_1}} \exp\left(-\frac{((k+1)(u-l))^2}{2t\sigma_1^2}\right) \\
&\quad + 2 \sum_{k=-\infty}^{\infty} (-1)^k \int_0^t \hat{g}'(t-s) \frac{s^{-\frac{1}{2}}}{\sqrt{2\pi\sigma_1}} \exp\left(-\frac{((k+1)(u-l))^2}{2s\sigma_1^2}\right) ds \\
&= -2 \sum_{k=-\infty}^{\infty} (-1)^k (\hat{g}(0+) - 1) \frac{t^{-\frac{1}{2}}}{\sqrt{2\pi\sigma_1}} \exp\left(-\frac{(k(u-l))^2}{2t\sigma_1^2}\right) \\
&\quad - 2 \sum_{k=-\infty}^{\infty} (-1)^k \int_0^t \hat{g}'(t-s) \frac{s^{-\frac{1}{2}}}{\sqrt{2\pi\sigma_1}} \exp\left(-\frac{(k(u-l))^2}{2s\sigma_1^2}\right) ds \\
&= -\frac{2(\hat{g}(0+) - 1)}{\sqrt{2\pi\sigma_1}} t^{-\frac{1}{2}} - \frac{4(\hat{g}(0+) - 1)}{\sqrt{2\pi\sigma_1}} t^{-\frac{1}{2}} \sum_{k=1}^{\infty} (-1)^k \exp\left(-\frac{(k(u-l))^2}{2t\sigma_1^2}\right) \\
&\quad - \frac{2}{\sqrt{2\pi\sigma_1}} \int_0^t \hat{g}'(t-s) s^{-\frac{1}{2}} ds \\
&\quad - \frac{4}{\sqrt{2\pi\sigma_1}} \sum_{k=1}^{\infty} (-1)^k \int_0^t \hat{g}'(t-s) s^{-\frac{1}{2}} \exp\left(-\frac{(k(u-l))^2}{2s\sigma_1^2}\right) ds.
\end{aligned}$$

The Laplace transformation of this identity implies that

$$\begin{aligned}
&-\mathcal{L} \left[\lim_{x \downarrow l} \partial_x \hat{Q}(\cdot, x) \right] (\lambda) \\
&= \frac{2(\hat{g}(0+) - 1)}{\sqrt{2\pi\sigma_1}} \mathcal{L} \left[(\cdot)^{-\frac{1}{2}} \right] (\lambda) \\
&\quad + \frac{4(\hat{g}(0+) - 1)}{\sqrt{2\pi\sigma_1}} \sum_{k=1}^{\infty} (-1)^k \mathcal{L} \left[(\cdot)^{-\frac{1}{2}} \exp\left(-\frac{(k(u-l))^2}{2\sigma_1^2(\cdot)}\right) \right] (\lambda) \\
&\quad + \frac{2}{\sqrt{2\pi\sigma_1}} \mathcal{L} [\hat{g}'] (\lambda) \mathcal{L} \left[(\cdot)^{-\frac{1}{2}} \right] \\
&\quad + \frac{4}{\sqrt{2\pi\sigma_1}} \sum_{k=1}^{\infty} (-1)^k \mathcal{L} [\hat{g}'] (\lambda) \mathcal{L} \left[(\cdot)^{-\frac{1}{2}} \exp\left(-\frac{(k(u-l))^2}{2\sigma_1^2(\cdot)}\right) \right] (\lambda) \\
&= \frac{\hat{g}(0+) - 1}{\sigma_1} \sqrt{\frac{2}{\lambda}} \left(1 + 2 \sum_{k=1}^{\infty} (-1)^k \exp\left(-\frac{k(u-l)}{\sigma_1} \sqrt{2\lambda}\right) \right) \\
&\quad + \frac{1}{\sigma_1} \sqrt{\frac{2}{\lambda}} (\lambda F(\lambda) - \hat{g}(0+)) \left(1 + 2 \sum_{k=1}^{\infty} (-1)^k \exp\left(-\frac{k(u-l)}{\sigma_1} \sqrt{2\lambda}\right) \right) \\
&= \sqrt{\frac{2}{\lambda}} \frac{1}{\sigma_1} (\hat{g}(0+) - 1 + \lambda F(\lambda) - \hat{g}(0+)) \left(1 + 2 \sum_{k=1}^{\infty} (-1)^k \exp\left(-\frac{k(u-l)}{\sigma_1} \sqrt{2\lambda}\right) \right) \\
&= \sqrt{\frac{2}{\lambda}} \frac{1}{\sigma_1} (\lambda F(\lambda) - 1) \left(1 + 2 \sum_{k=1}^{\infty} (-1)^k \exp\left(-\frac{k(u-l)}{\sigma_1} \sqrt{2\lambda}\right) \right) \\
&= \sqrt{\frac{2}{\lambda}} \frac{1}{\sigma_1} (\lambda F(\lambda) - 1) \left(-1 + \frac{2}{1 + \exp\left(-\frac{u-l}{\sigma_1} \sqrt{2\lambda}\right)} \right)
\end{aligned}$$

$$\begin{aligned}
&= \sqrt{\frac{2}{\lambda}} \frac{1}{\sigma_1} (\lambda F(\lambda) - 1) \tanh\left(\frac{u-l}{\sqrt{2}\sigma_1} \sqrt{\lambda}\right) \\
&= \sqrt{\frac{2}{\lambda}} \frac{1}{\sigma_1} \frac{-\frac{\sigma_1}{\sigma_2} \coth\left(\frac{u-l}{\sqrt{2}\sigma_1} \sqrt{\lambda}\right)}{\frac{\sigma_1}{\sigma_2} \coth\left(\frac{u-l}{\sqrt{2}\sigma_1} \sqrt{\lambda}\right) + 1} \tanh\left(\frac{u-l}{\sqrt{2}\sigma_1} \sqrt{\lambda}\right) \\
&= -\sqrt{\frac{2}{\lambda}} \frac{1}{\sigma_2} \frac{1}{\frac{\sigma_1}{\sigma_2} \coth\left(\frac{u-l}{\sqrt{2}\sigma_1} \sqrt{\lambda}\right) + 1}.
\end{aligned}$$

Hence, we obtain $\mathcal{L}\left[\lim_{x \downarrow l} \partial_x \hat{Q}(\cdot, x)\right](\lambda) = \mathcal{L}\left[\lim_{x \uparrow l} \partial_x \hat{Q}(\cdot, x)\right](\lambda)$. Since $\partial_x \hat{Q}(\cdot, x)$ is continuous on $(0, \infty)$ for all $x \in \mathbb{R} \setminus \{l, u\}$ the injectivity of the Laplace transformation implies that

$$\lim_{x \downarrow l} \partial_x \hat{Q}(t, x) = \lim_{x \uparrow l} \partial_x \hat{Q}(t, x), \quad t > 0,$$

see e.g. Theorem 5.4 in [3]. Symmetry implies that $\lim_{x \uparrow u} \partial_x \hat{Q}(t, x) = \lim_{x \downarrow u} \partial_x \hat{Q}(t, x)$. Finally, we have $\hat{Q} \in \mathcal{C}^{1,2}((0, \infty) \times \mathbb{R} \setminus \{l, u\}) \cap \mathcal{C}^{0,1}((0, \infty) \times \mathbb{R})$. \square

References

- [1] S. Ankirchner, C. Blanchet-Scalliet, and M. Jeanblanc. “Controlling the occupation time of an exponential martingale”. In: *Appl. Math. Optim.* 76.2 (2017), pp. 415–428.
- [2] A. N. Borodin and P. Salminen. *Handbook of Brownian Motion—Facts and Formulae*. Second. Probability and its Applications. Birkhäuser Verlag, Basel, 2002.
- [3] G. Doetsch. *Introduction to the theory and application of the Laplace transformation*. Translated from the second German edition by Walter Nader. Springer-Verlag, New York-Heidelberg, 1974.
- [4] I. Karatzas and S. E. Shreve. *Brownian motion and stochastic calculus*. Second. Vol. 113. Graduate Texts in Mathematics. Springer-Verlag, New York, 1991.
- [5] N. V. Krylov. *Controlled diffusion processes*. Vol. 14. Stochastic Modelling and Applied Probability. Translated from the 1977 Russian original by A. B. Aries, Reprint of the 1980 edition. Springer-Verlag, Berlin, 2009.
- [6] J. M. McNamara. “Optimal control of the diffusion coefficient of a simple diffusion process”. In: *Mathematics of Operations Research* 8.3 (1983), pp. 373–380.
- [7] S. Nakao. “On the pathwise uniqueness of solutions of one-dimensional stochastic differential equations”. In: *Osaka Journal of Mathematics* 9.3 (1972), pp. 513–518.