



**HAL**  
open science

# On the Digital Control of MEMS Gyroscopes: a Robust Approach

Fabricio Saggin, Cécile Pernin, Anton Korniienko, Gérard Scorletti,  
Christophe Le Blanc

► **To cite this version:**

Fabricio Saggin, Cécile Pernin, Anton Korniienko, Gérard Scorletti, Christophe Le Blanc. On the Digital Control of MEMS Gyroscopes: a Robust Approach. [Research Report] Ecole Centrale de Lyon. 2021. hal-03125932v2

**HAL Id: hal-03125932**

**<https://hal.science/hal-03125932v2>**

Submitted on 8 Feb 2021

**HAL** is a multi-disciplinary open access archive for the deposit and dissemination of scientific research documents, whether they are published or not. The documents may come from teaching and research institutions in France or abroad, or from public or private research centers.

L'archive ouverte pluridisciplinaire **HAL**, est destinée au dépôt et à la diffusion de documents scientifiques de niveau recherche, publiés ou non, émanant des établissements d'enseignement et de recherche français ou étrangers, des laboratoires publics ou privés.

# On the Digital Control of MEMS Gyroscopes: a Robust Approach

Fabrício Saggin\*, Cécile Pernin\*, Anton Korniienko\*, Gérard Scorletti\* and Christophe Le Blanc†

\* Laboratoire Ampère, Ecole Centrale de Lyon, Université de Lyon, France

† Asygn, Grenoble, France

## I. ABSTRACT

This document provides further details on the paper “Digital Control of MEMS Gyroscopes: a Robust Approach” [1]. These details concern the choice of the weighting functions for the  $H_\infty$  synthesis.

## II. SYSTEM DESCRIPTION AND CONTROL OBJECTIVES

As described in [1], the object of study is the control of a MEMS gyroscope.

The considered control architecture is represented in Fig. 1, where  $G_c$  is the model of the gyroscope with actuation and instrumentation, and  $K_c$  is the controller. Both are Multi Input Multi Output (MIMO) systems, in continuous time (CT). The controller  $K_c$  directly applies a signal  $u_x$  (resp.  $u_y$ ) on the drive (resp. sense) mode. The signal  $d_x$  (resp.  $d_y$ ) is the disturbance on  $u_x$  (resp.  $u_y$ ) and represents the Coriolis force acting on the drive (resp. sense) mode. Thus, estimating  $d_y$  allows to compute the Coriolis force, and then the angular rate. The input signals of  $G_c$  are  $u_{d_x}$  and  $u_{d_y}$ . The outputs of  $G_c$  are the signals  $x$  and  $y$ , representing voltages proportional respectively to the displacements on the drive mode and on the sense mode. The measurement noise is denoted  $n_x$  (resp.  $n_y$ ) on the drive (resp. sense) mode. The resonance frequency (in rad/s) of the drive (resp. sense) mode is denoted  $\omega_{0_x}$  (resp.  $\omega_{0_y}$ ).

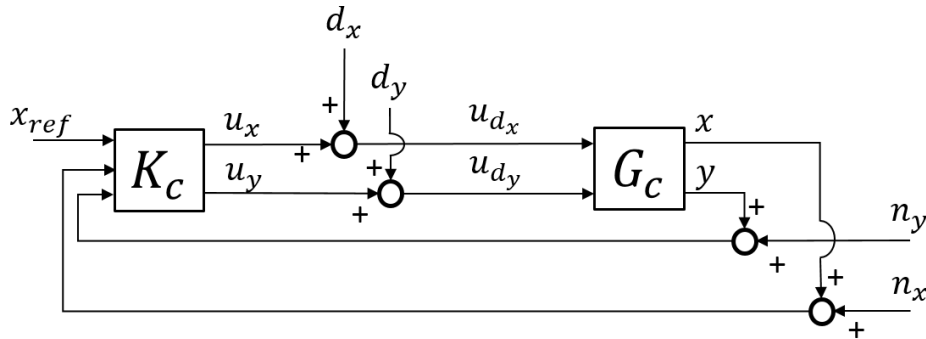

Fig. 1: Control architecture.

A discrete-time (DT) model of the gyroscope is obtained by identification and the electrical coupling is compensated, as described in [2], [3]. From the DT model, a CT model  $G_c$  is obtained by using the bilinear (or Tustin) transform. A controller  $K_c$  is calculated from  $G_c$ . The frequency distortion induced by the bilinear transform is compensated when the bilinear transform is applied to  $K_c$ , obtaining a DT controller  $K_d$ .

The Bode diagram of the gyroscope  $G_c$  is presented in Fig. 2 and  $G_c$  is partitioned as follows:

$$G_c(s) = \begin{bmatrix} G_{c_{xx}}(s) & G_{c_{xy}}(s) \\ G_{c_{yx}}(s) & G_{c_{yy}}(s) \end{bmatrix}, \quad (1)$$

where the main dynamic of  $G_{c_{xx}}$  (resp.  $G_{c_{yy}}$ ) corresponds to a resonator with resonance frequency  $\omega_{0_x}$  (resp.  $\omega_{0_y}$ ) and quality factor  $Q_x$  (resp.  $Q_y$ ). The transfers  $G_{c_{xy}}$  and  $G_{c_{yx}}$  model the couplings between drive and sense modes. The transfer  $G_{c_{yx}}$  presents resonance peaks at  $\omega_{0_x}$  and  $\omega_{0_y}$  and a magnitude that is globally smaller than that of  $G_{c_{xx}}$  and  $G_{c_{yy}}$ . The transfer  $G_{c_{xy}}$  is negligible for the MEMS sensor used in this study. Finally, the actuation and instrumentation circuitry justifies the phase of the transfers.

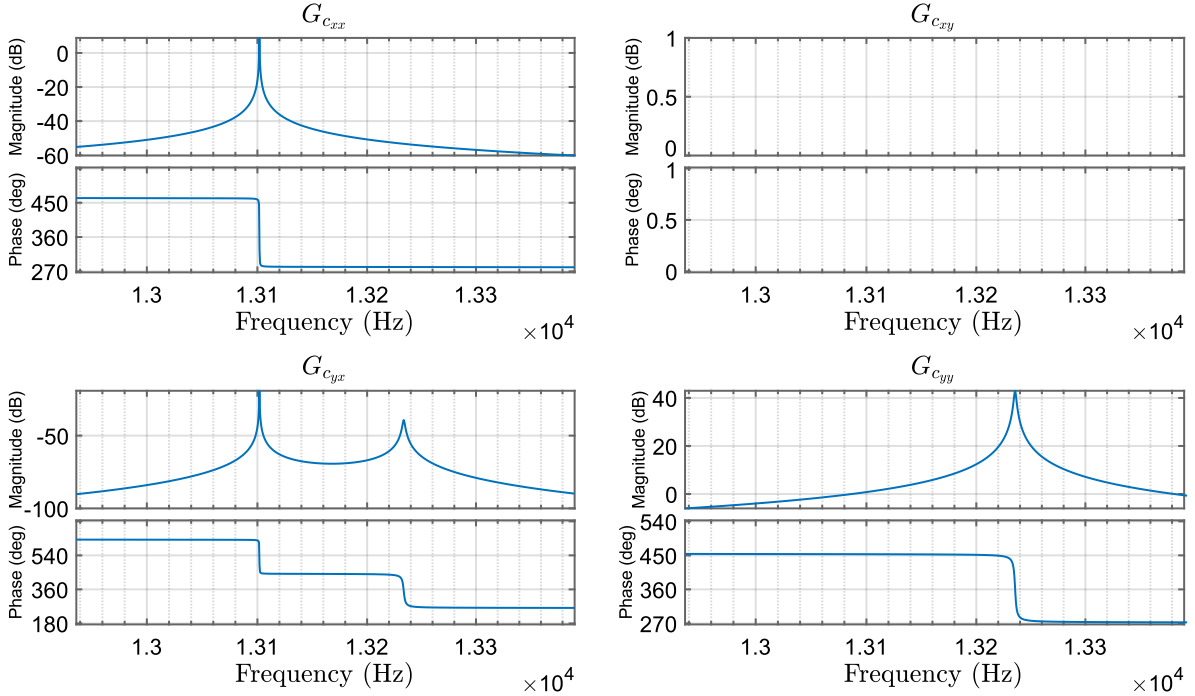

Fig. 2: Bode diagram of the gyroscope model.

The main control specifications are :

- 1) Track the sinusoidal reference signal  $x_{ref}(t) = A_{ref} \sin(\omega_{0_x} t)$  with an error  $\varepsilon_x(t) = x_{ref}(t) - x(t)$ , such that  $|\varepsilon_x| < \varepsilon_{x_{max}} |A_{ref}|$  in steady-state, where  $A_{ref} \in \mathbb{R}$  and  $\varepsilon_{x_{max}} \in \mathbb{R}^+$ .
- 2) Reject the disturbance  $d_y(t) = A_{d_y} \sin(\omega_{0_x} t + \phi_y)$  on the signal  $u_{d_y}$ , *i.e.*, with a maximum error  $u_{d_y}$  such that  $|u_{d_y}| < \varepsilon_{u_{max}} |A_{d_y}|$ , where  $A_{d_y} \in \mathbb{R}$ ,  $\phi_y \in \mathbb{R}$  and  $\varepsilon_{u_{max}} \in \mathbb{R}^+$ .
- 3) Robust stability against model uncertainties in low and high frequencies.

Secondary control objectives are also considered:

- Minimize the control effort  $u_x$  on the drive mode.
- Limit the influence of the measurement noises  $n_x$  and  $n_y$ .
- Reject the disturbance  $d_x(t) = A_{d_x} \sin(\omega_{0_x} t + \phi_x)$  with an error  $\varepsilon'_x(t) = x(t)$ , such that  $|\varepsilon'_x| < \varepsilon'_{x_{max}} |A_{d_x}|$  in steady-state, where  $A_{d_x} \in \mathbb{R}$ ,  $\phi_x \in \mathbb{R}$  and  $\varepsilon'_{x_{max}} \in \mathbb{R}^+$ .

### III. CHOICE OF THE WEIGHTING FUNCTION PARAMETERS

In the  $H_\infty$  synthesis, the controller design is formulated as an optimization problem subject to mathematical constraints, which express performance and stability robustness requirements into a mathematical criterion to be minimized. The choice of the input and output signals and of the weighting functions, *i.e.*, the so-called  $H_\infty$  criterion, must be adapted to the specifications.

We consider the criterion presented in Fig. 3, where the signals of interest  $\tilde{w} = (x_{ref}, d_x, d_y, n_x, n_y)^T$  and  $\tilde{z} = (\varepsilon_x, u_x, u_{d_y})^T$ , weighting functions  $W_w = \text{diag}(W_{w_1}, \dots, W_{w_5})$  and  $W_z = \text{diag}(W_{z_1}, \dots, W_{z_3})$  are defined with  $w = (w_1, w_2, w_3, w_4, w_5)^T = W_w^{-1} \tilde{w}$  and  $z = (z_1, z_2, z_3)^T = W_z \tilde{z}$ .

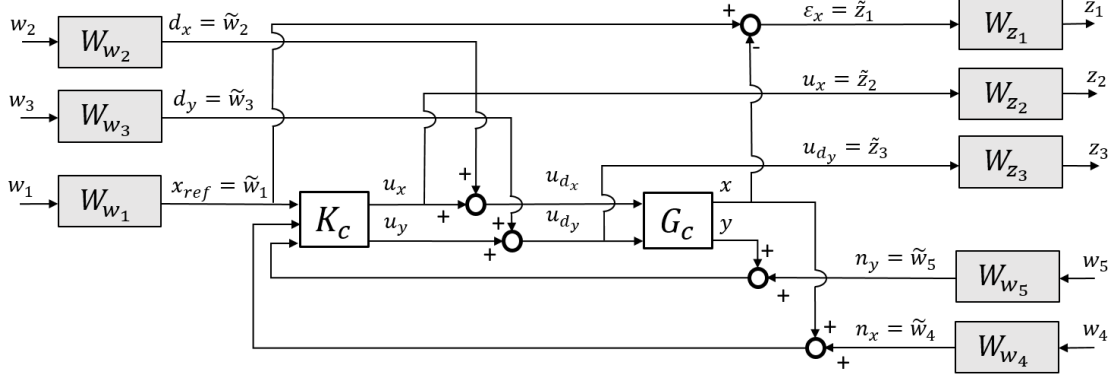

Fig. 3:  $H_\infty$  criterion.

The  $H_\infty$  problem is the following: for a given  $\gamma$ , find a controller such that the weighted closed-loop transfer functions are stable and

$$\left\| \begin{bmatrix} T_{w_1 \rightarrow z_1} & T_{w_2 \rightarrow z_1} & T_{w_3 \rightarrow z_1} & T_{w_4 \rightarrow z_1} & T_{w_5 \rightarrow z_1} \\ T_{w_1 \rightarrow z_2} & T_{w_2 \rightarrow z_2} & T_{w_3 \rightarrow z_2} & T_{w_4 \rightarrow z_2} & T_{w_5 \rightarrow z_2} \\ T_{w_1 \rightarrow z_3} & T_{w_2 \rightarrow z_3} & T_{w_3 \rightarrow z_3} & T_{w_4 \rightarrow z_3} & T_{w_5 \rightarrow z_3} \end{bmatrix} \right\|_\infty < \gamma, \quad (2)$$

where we use the notation  $T_{a \rightarrow b}$  to denote the transfer from a signal  $a$  to a signal  $b$ .

If the above problem has a solution with  $\gamma < 1$ , then it can be shown (see [4]) that (2) implies

$$\forall \omega \in \mathbb{R}, \forall k \in \{1, \dots, 5\}, \forall l \in \{1, \dots, 3\}, |T_{\tilde{w}_k \rightarrow \tilde{z}_l}(j\omega)| < |W_{w_k}(j\omega)W_{z_l}(j\omega)|^{-1}. \quad (3)$$

Therefore, the choice of the weighting functions allows to impose upper bounds on the magnitude of the closed-loop transfer functions and thus to ensure compliance with the specifications, which are themselves expressed as upper bounds.

Two main types of dynamic weighting functions are used in this work, which are adapted to the reference tracking and disturbance rejection of sinusoidal signals [5]:

- 1) An ‘‘amplification’’ weighting function  $W_{amp}$

$$W_{amp}(k, W_{max}, W_{int}, \omega_{min}, \omega_{max}, s) = k \cdot \frac{s^2 + \alpha s + \omega_{min}\omega_{max}}{s^2 + \alpha/W_{max} \cdot s + \omega_{min}\omega_{max}} \quad (4)$$

with

$$\alpha = (\omega_{max} - \omega_{min}) \cdot W_{max} \cdot \sqrt{\frac{W_{int}^2 - 1}{W_{max}^2 - W_{int}^2}}, \quad (5)$$

where  $k > 0$ ,  $W_{max} > W_{int} > 0$  and  $\omega_{max} > \omega_{min} > 0$  can be chosen by the user. The magnitude plot of this type of weighting function is given in Fig. 4, with  $\omega_0^2 = \omega_{min} \cdot \omega_{max}$ .

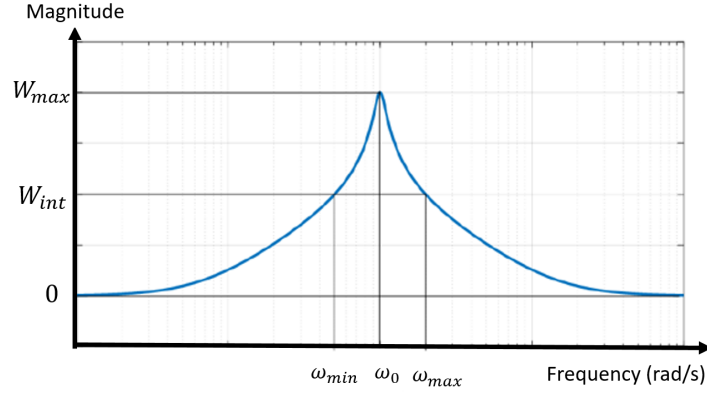

Fig. 4: Magnitude plot of  $W_{amp}/k$ .

2) An “attenuation” weighting function  $W_{att}$

$$W_{att}(k, W_{min}, W_{int}, \omega_{min}, \omega_{max}, s) = k \cdot \frac{s^2 + \beta W_{min} s + \omega_{min} \omega_{max}}{s^2 + \beta s + \omega_{min} \omega_{max}} \quad (6)$$

with

$$\beta = (\omega_{max} - \omega_{min}) \cdot \sqrt{\frac{1 - W_{int}^2}{W_{int}^2 - W_{min}^2}} \quad (7)$$

The magnitude of this transfer is given in Fig. 5, with  $\omega_0^2 = \omega_{min} \cdot \omega_{max}$ .

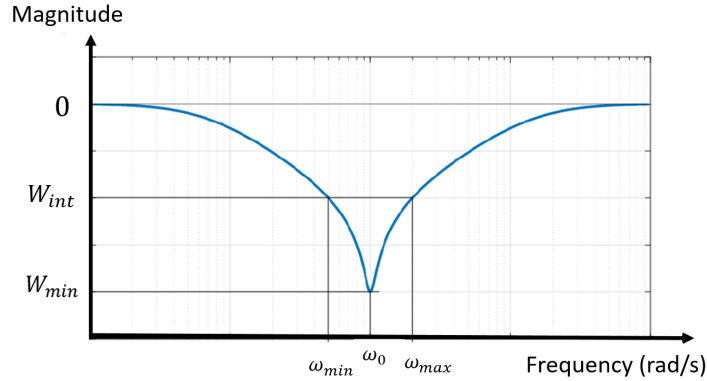

Fig. 5: Magnitude plot of  $W_{att}/k$ .

The desired specifications can be expressed through the choice of the weighting functions and their parameters, as follows.

### Main Control Specifications

- *Reference tracking:*

The signals of interest are  $x_{ref}$ , the reference signal, and  $\varepsilon_x$ , the tracking error to be minimized. The function to be worked on is  $T_{x_{ref} \rightarrow \varepsilon_x}$ . The objective is to track a sinusoidal reference signal  $x_{ref}$  of frequency  $\omega_{0_x}$ . More precisely, the first control specification demands:

$$|T_{x_{ref} \rightarrow \varepsilon_x}(j\omega_{0_x})| < \varepsilon_{x_{max}} \quad (8)$$

For  $k = l = 1$ , (3) is equivalent to

$$\forall \omega \in \mathbb{R}, |T_{x_{ref} \rightarrow \varepsilon_x}(j\omega)| < |W_{z_1}(j\omega)W_{w_1}(j\omega)|^{-1}. \quad (9)$$

Thus, (8) can be enforced using (9) via the product  $W_{z_1} W_{w_1}$ . The weighting functions must be chosen so that  $|W_{w_1}(j\omega_{0_x})W_{z_1}(j\omega_{0_x})|^{-1} \leq \varepsilon_{x_{max}}$ .

The weighting functions are selected such that:

$$W_{w_1} \cdot W_{z_1} = W_{amp}(k_1, W_{max_1}, W_{int_1}, \omega_{min_1}, \omega_{max_1}) \quad (10)$$

with

$$\begin{cases} \omega_{max_1} = \omega_{0_x} + \delta\omega_x \\ \omega_{min_1} = \omega_{0_x} - \delta\omega_x, \\ W_{int_1} = \frac{1}{\varepsilon_{x_{max}} \cdot k_1} \end{cases} \quad (11)$$

where  $\delta\omega_x > 0$  is associated with the reference tracking bandwidth,  $k_1 > 0$  and  $W_{max_1} > 0$ . In general, these last parameters are chosen by the user iteratively.

- *Disturbance rejection on the sense mode:*

The signals of interest are  $d_y$ , the disturbance, and  $u_{d_y}$ , the estimation error to be minimized. The function to be worked on is  $T_{d_y \rightarrow u_{d_y}}$ . The second control specification demands:

$$\left| T_{d_y \rightarrow u_{d_y}}(j\omega_{0_x}) \right| < \varepsilon_{u_{max}} \quad (12)$$

With  $k = l = 3$ , (3) is equivalent to

$$\forall \omega \in \mathbb{R}, \left| T_{d_y \rightarrow u_{d_y}}(j\omega) \right| < |W_{w_3}(j\omega)W_{z_3}(j\omega)|^{-1}. \quad (13)$$

Similar to the reference tracking, the weighting functions are such that:

$$W_{w_3} \cdot W_{z_3} = W_{amp}(k_2, W_{max_2}, W_{int_2}, \omega_{min_2}, \omega_{max_2}) \quad (14)$$

with

$$\begin{cases} \omega_{max_2} = \omega_{0_x} + \delta\omega_y \\ \omega_{min_2} = \omega_{0_x} - \delta\omega_y, \\ W_{int_2} = \frac{1}{\varepsilon_{u_{max}} \cdot k_2} \end{cases} \quad (15)$$

where  $\delta\omega_y > 0$  is associated with the bandwidth of the disturbance rejection on the sense mode,  $k_2 > 0$  and  $W_{max_2} > 0$ . In general, these last parameters are chosen by the user iteratively.

- *Robustness against model uncertainties:*

The identification experiment also provides the model uncertainties related to the drive and sense modes [3]. In general, due to the band-pass characteristic of these resonant modes, the identified model is accurate for the frequencies close to the resonance frequencies, while it is rather uncertain in low and high frequencies.

Qualitatively, to ensure the robust stability of the system against this type of uncertainty, the transfers from  $n_x$  and  $n_y$  to  $u_x$  and  $u_{d_y}$  must present the following property: the magnitude is small in the frequency range where the uncertainties are important; and the magnitude can be important where the uncertainties are small [4]. Therefore, the corresponding weighting functions have to present high gains in low and high frequencies, and small gains around the resonance frequencies, similar to attenuation function.

## Secondary Control Specifications

- *Minimization of the control effort on the drive mode.*

The signal of interest is  $u_x$ . All the transfer functions which have  $u_x$  as output signal are considered, but here, we focus on  $T_{x_{ref} \rightarrow u_x}$ , corresponding to the control effort to track the sinusoidal reference on the drive mode. Equation (3) implies that

$$\forall \omega \in \mathbb{R}, \left| T_{x_{ref} \rightarrow u_x}(j\omega) \right| < |W_{w_1}(j\omega)W_{z_2}(j\omega)|^{-1} \quad (16)$$

The gain of  $T_{x_{ref} \rightarrow u_x}(j\omega)$  at  $\omega_{0_x}$  is constrained by the specification of tracking, (*i.e.*, the value of  $\varepsilon_{x_{max}}$ ) and the gains of the gyroscope at  $\omega_{0_x}$ :  $T_{x_{ref} \rightarrow u_x}(j\omega_{0_x})$  cannot be lowered under a minimal value, necessary to ensure the desired reference tracking performance. Consequently, the control effort can only be influenced to a limited extent in steady state. This reasoning is actually valid not only at  $\omega_{0_x}$ , but also on all the bandwidth  $\delta\omega_x$  associated with reference tracking.

However, it is possible to limit the control effort in transient state by minimizing as much as possible the gain of  $T_{x_{ref} \rightarrow u_x}(j\omega)$  outside the bandwidth  $[\omega_{0_x} - \delta\omega_x; \omega_{0_x} + \delta\omega_x]$ . This also enforces the robust stability [4]. The weighting functions are chosen so that  $W_{w_1} \cdot W_{z_2}$  behaves like an attenuation function, that is, with low gains around  $\omega_{0_x}$  and high gains in low and high frequencies.

- *Limit the influence of the measurement noises  $n_x$  and  $n_y$*

The signals of interests are  $n_x$  and  $n_y$ . The weighting functions are designed to minimize the magnitude of the transfer functions that have  $n_x$  and  $n_y$  as inputs, for all frequencies. However, similarly to the control effort minimization, trade-offs have to be made between the desired reference tracking and disturbance rejection performances on the one hand, and the noise attenuation on the other hand. Consequently, the weighting functions related to the signals  $n_x$  and  $n_y$  are chosen so that the transfer functions having  $n_x$  and  $n_y$  as inputs behave like attenuation functions, that is, with low gains around  $\omega_{0_x}$  and high gains in low and high frequencies.

- *Disturbance rejection on the drive mode*

The disturbance  $d_x$  represents the Coriolis force acting on the drive mode. The reasoning is the same as for the disturbance rejection on the sense mode, and the weighting functions can be chosen as:

$$W_{w_2} \cdot W_{z_1} = W_{amp}(k_3, W_{max_3}, W_{int_3}, \omega_{min_3}, \omega_{max_3}) \quad (17)$$

with

$$\begin{cases} \omega_{max_3} = \omega_{0_x} + \delta\omega'_x \\ \omega_{min_3} = \omega_{0_x} - \delta\omega'_x \\ W_{int_3} = \frac{1}{\varepsilon'_{x_{max}} \cdot k_3} \end{cases}, \quad (18)$$

where  $\delta\omega'_x > 0$  is associated with the bandwidth of the disturbance rejection on the drive mode,  $\varepsilon'_{x_{max}}$  corresponds to the disturbance rejection error,  $k_3 > 0$  and  $W_{max_1} > 0$ . In general, these last parameters are chosen by the user iteratively.

The final choice of the weighting functions is made keeping in mind that the more important the total order of the weighting functions is, the more important the order of the controller is.

The following numerical values are selected:

$$\begin{cases} \varepsilon_{x_{max}} = 0.005 \\ \delta\omega_x = 2 \text{ rad/s} \\ \varepsilon_{u_{max}} = 0.01 \\ \delta\omega_y = 7 \text{ rad/s} \\ \varepsilon'_{x_{max}} = 0.005 \\ \delta\omega'_x = 2 \text{ rad/s} \end{cases} \quad (19)$$

The selected weighting functions are the following:

$$\begin{cases} W_{w_1} = W_{amp}(k_1, W_{max_1}, W_{int_1}, \omega_{min_1}, \omega_{max_1}) \\ W_{w_2} = W_{amp}(k_3, W_{max_3}, W_{int_3}, \omega_{min_3}, \omega_{max_3}) \\ W_{w_3} = W_{amp}(k_2, W_{max_2}, W_{int_2}, \omega_{min_2}, \omega_{max_2}) \\ W_{z_1} = 1 \\ W_{z_2} = W_{att}(k_4, W_{min_4}, W_{int_4}, \omega_{min_4}, \omega_{max_4}) \\ W_{z_3} = 1 \\ W_{z_4} = W_{att}(k_5, W_{min_5}, W_{int_5}, \omega_{min_5}, \omega_{max_5}) \\ W_{z_5} = W_{att}(k_6, W_{min_6}, W_{int_6}, \omega_{min_6}, \omega_{max_6}) \end{cases} \quad (20)$$

All the parameters of these functions are given in Table I.

TABLE I: Numerical values of the parameters of the weighting functions

$k_1$	$k_2$	$k_3$	$k_4$	$k_5$	$k_6$
$10^{-8/20}$	$10^{-8/20}$	$10^{-8/20}$	$10^{40/20}$	$10^{80/20}$	$10^{40/20}$
$W_{int_1}$	$W_{int_2}$	$W_{int_3}$	$W_{int_4}$	$W_{int_5}$	$W_{int_6}$
$1/(\varepsilon_{x_{max}} \cdot k_1)$	$1/(\varepsilon_{u_{max}} \cdot k_2)$	$1/(\varepsilon'_{x_{max}} \cdot k_3)$	0.001	0.0178	0.224
$W_{max_1}$	$W_{max_2}$	$W_{max_3}$	$W_{min_4}$	$W_{min_5}$	$W_{min_6}$
$4 \cdot W_{int_1}$	$5 \cdot W_{int_2}$	$4 \cdot W_{int_3}$	$10^{-5}$	$5.6234 \cdot 10^{-5}$	$10^{40/20}$
$\omega_{min_1}$	$\omega_{min_2}$	$\omega_{min_3}$	$\omega_{min_4}$	$\omega_{min_5}$	$\omega_{min_6}$
$\omega_{0_x} - \delta\omega_x$	$\omega_{0_x} - \delta\omega_y$	$\omega_{0_x} - \delta\omega'_x$	0.6	0.75	0.9
$\omega_{max_1}$	$\omega_{max_2}$	$\omega_{max_3}$	$\omega_{max_4}$	$\omega_{max_5}$	$\omega_{max_6}$
$\omega_{0_x} + \delta\omega_x$	$\omega_{0_x} + \delta\omega_y$	$\omega_{0_x} + \delta\omega'_x$	1.6667	1.333	1.111

#### IV. SYNTHESIS RESULTS

In this work, the *Robust Control Toolbox* of Matlab<sup>®</sup> [6] is used to solve the  $H_\infty$  control problem.

With the model  $G_c$  and the weighting functions of the previous section, the  $H_\infty$  problem (see (2)) is solved with  $\gamma = 0.95$ . The closed-loop transfer functions are presented in Fig. 8 and Fig. 9. The upper bounds imposed by the weighting functions are respected.

The magnitude of  $T_{x_{ref} \rightarrow \varepsilon_x}$  is low at the resonance frequency  $\omega_{0_x}$ : -68 dB, *i.e.*,  $4.10^{-4} < \varepsilon_{x_{max}}$ . Then, the tracking specification is respected.

The magnitude of  $T_{d_x \rightarrow \varepsilon_x}$  is low at the resonance frequency  $\omega_{0_x}$ : -50 dB, *i.e.*,  $3.10^{-3} < \varepsilon'_{x_{max}}$ . Then, the disturbance rejection specification on the drive mode is respected.

The magnitude of  $T_{d_y \rightarrow u_{d_y}}$  is low at the resonance frequency  $\omega_{0_x}$ : -55 dB, *i.e.*,  $2.10^{-3} < \varepsilon_{u_{max}}$ . Then, the disturbance rejection specification on the sense mode is respected.

The magnitude of the transfers with the noises  $n_x$  and  $n_y$  as inputs is minimized in low and high frequencies, limiting the influence of the measurement noises on the signals of interest and enhancing the robustness of the system against model uncertainties in these frequency ranges.

The Bode plot of the obtained controller  $K_c$  is represented in Fig. 6 and Fig. 7. It is reminded that  $In(1)$ , or  $Input(1)$ , is  $x_{ref}$ ;  $In(2)$  is  $x$ ;  $In(3)$  is  $y$ ;  $Out(1)$  is  $u_x$ ;  $Out(2)$  is  $u_y$ . The controller has important gains around the resonance frequency  $\omega_{0_x}$ , which enables to ensure a good tracking of  $x_{ref}$  and a good estimation of  $d_y$ . Its gains are weak in low and high frequencies, which enables to minimize the control effort in transient state, to limit the influence of the measurement noise on the signals of interest and to enhance robustness.



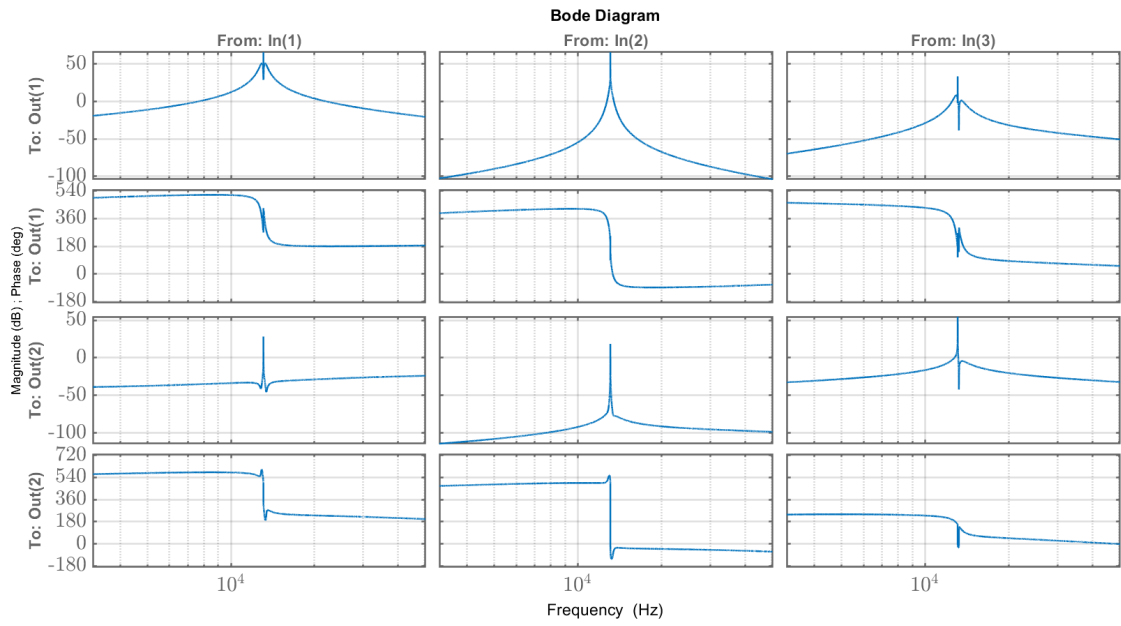

Fig. 6: Bode plot of  $K_c$ .

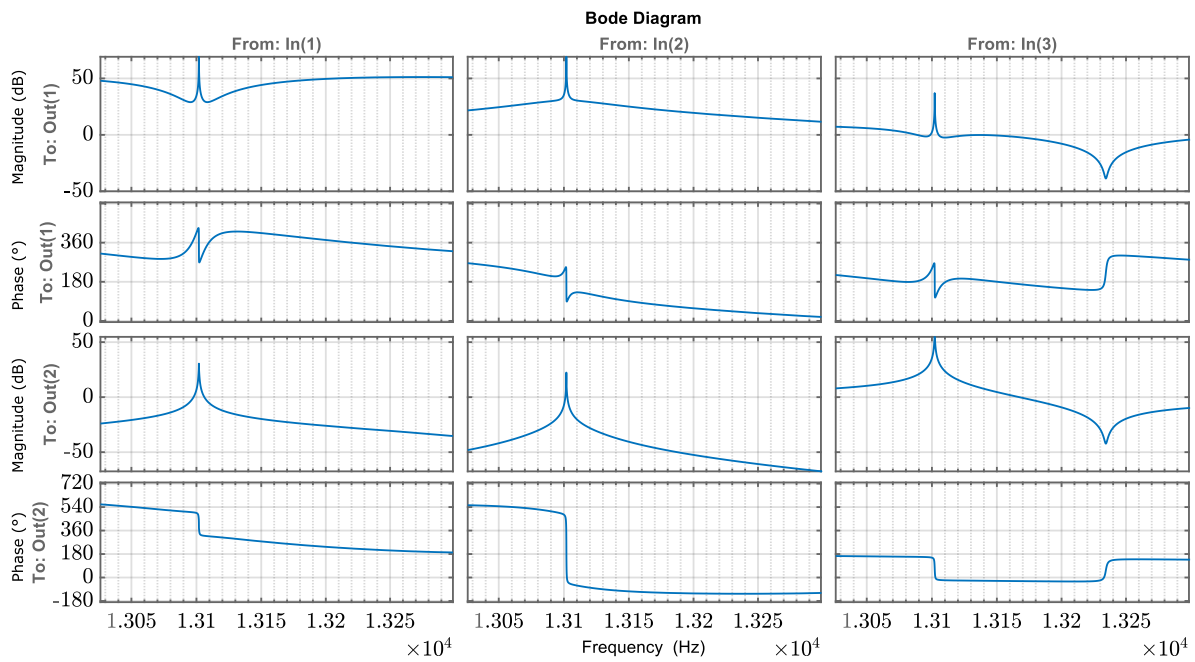

Fig. 7: Bode plot of  $K_c$  – zoom.

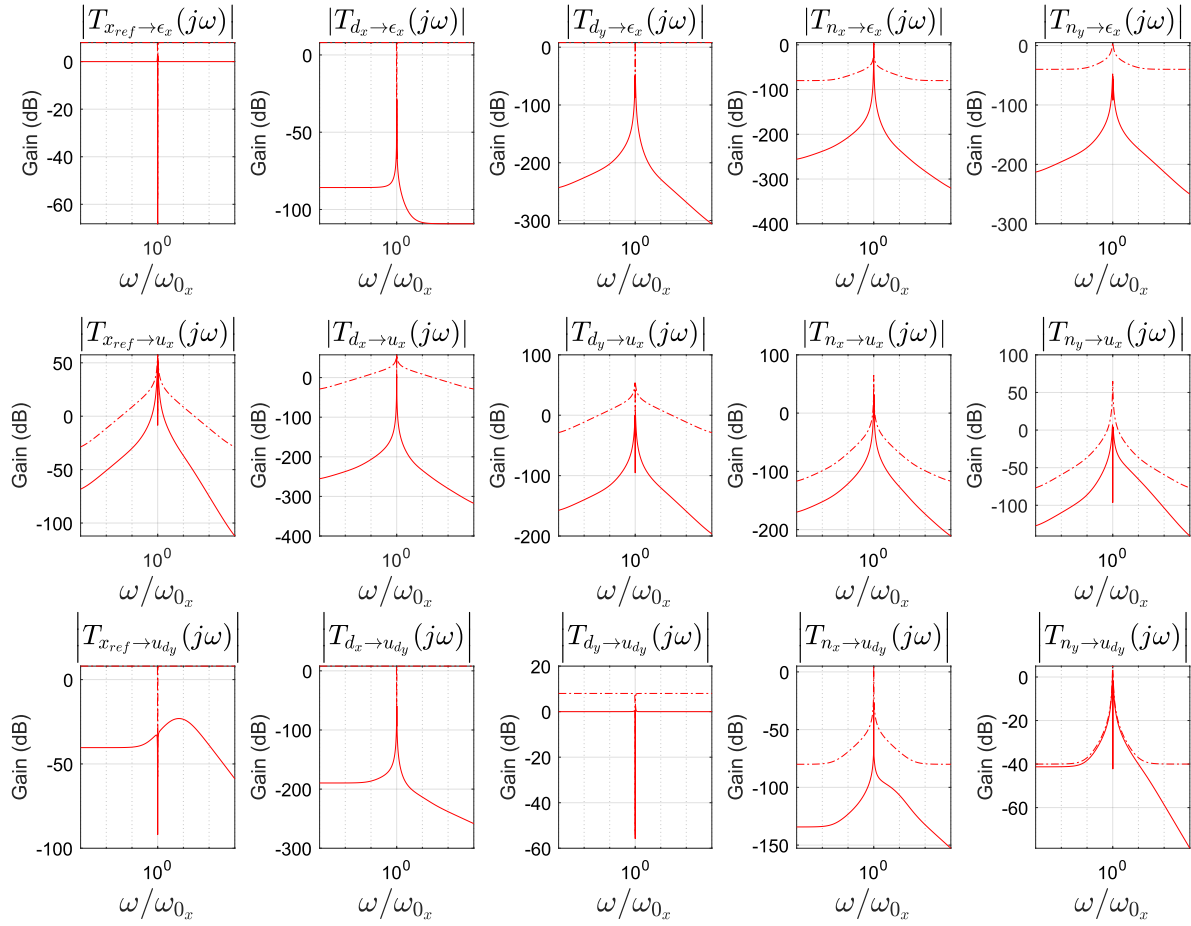

Fig. 8: Magnitudes of the closed-loop transfer functions (solid line) and upper bounds enforced by the weighting functions (dashed line).

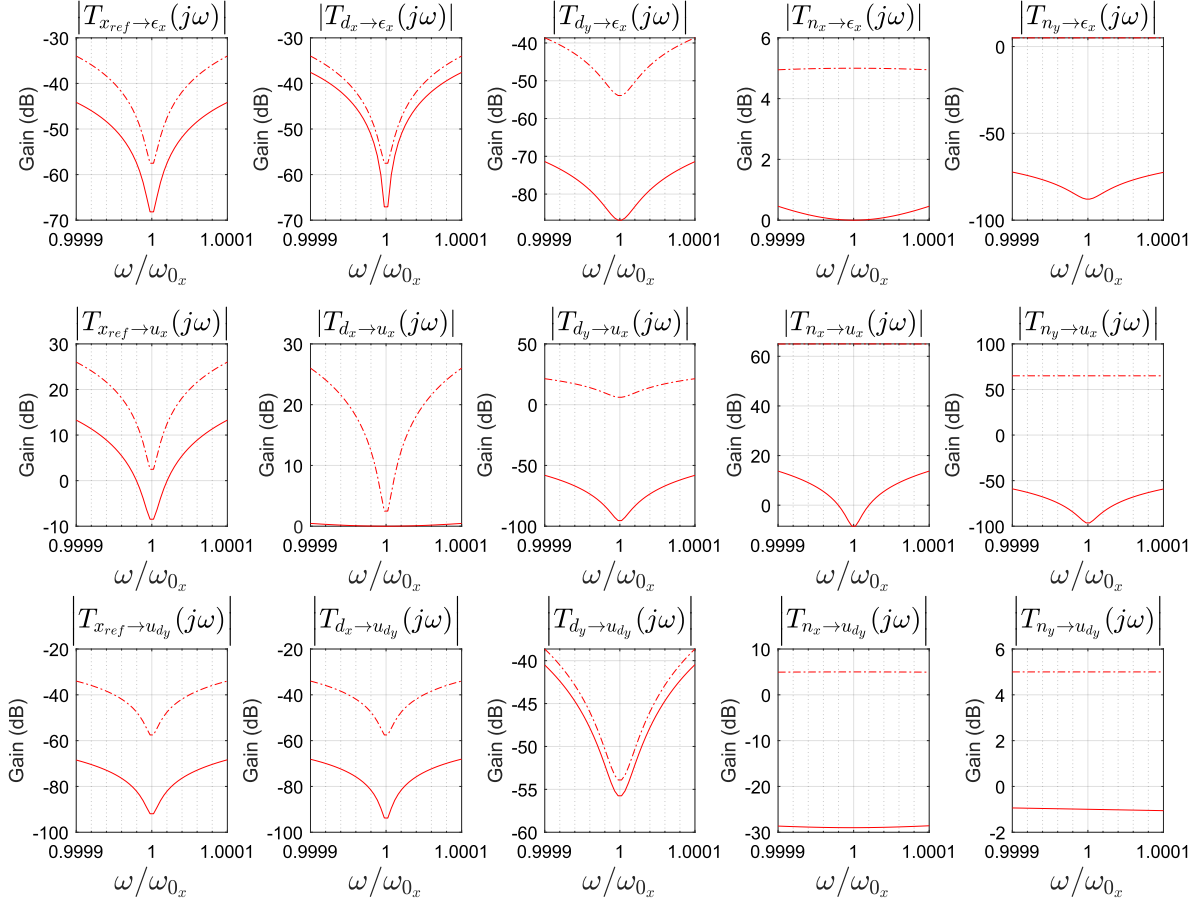

Fig. 9: Zoom around  $\omega_{0_x}$  on the magnitudes of the closed-loop transfer functions (solid line) and upper bounds enforced by the weighting functions (dashed line).

## REFERENCES

- [1] F. Saggini, C. Pernin, A. Kornienko, G. Scorletti, and C. Le Blanc, "Digital Control of MEMS Gyroscopes: a Robust Approach," in *IEEE International Symposium on Inertial Sensors and Systems (INERTIAL)*. (to be published), 2021.
- [2] K. Colin, F. Saggini, C. Le Blanc, X. Bombois, A. Kornienko, and G. Scorletti, "Identification-Based Approach for Electrical Coupling Compensation in a MEMS Gyroscope," in *IEEE International Symposium on Inertial Sensors and Systems (INERTIAL)*. IEEE, apr 2019, pp. 1–4. [Online]. Available: <https://hal.archives-ouvertes.fr/hal-02174925>
- [3] K. Colin, "Data informativity for the prediction error identification of MIMO systems : identification of a MEMS gyroscope," Theses, Université de Lyon, Sep. 2020. [Online]. Available: <https://tel.archives-ouvertes.fr/tel-03114994>
- [4] S. Skogestad and I. Postlethwaite, *Multivariable feedback control - analysis and design*, 2nd ed. John Wiley & Sons, 2001.
- [5] G. Scorletti and V. Fromion, *Automatique fréquentielle avancée*, 2009. [Online]. Available: <https://cel.archives-ouvertes.fr/cel-00423848v2>
- [6] G. Balas, R. Chiang, A. Packard, and M. Safonov, "The robust control toolbox of matlab," MathWork, Tech. Rep., 2020. [Online]. Available: [https://fr.mathworks.com/help/pdf\\_doc/robust/index.html](https://fr.mathworks.com/help/pdf_doc/robust/index.html)