



**HAL**  
open science

## Modeling interactions for inoperability management: from fault tree analysis (FTA) to dynamic bayesian network (DBN)

Ayeley Tchangani, François Pérès

### ► To cite this version:

Ayeley Tchangani, François Pérès. Modeling interactions for inoperability management: from fault tree analysis (FTA) to dynamic bayesian network (DBN). 4th IFAC Workshop on Advanced Maintenance Engineering, Services and Technologies - AMEST 2020, Sep 2020, Cambridge, United Kingdom. pp.342-347, 10.1016/j.ifacol.2020.11.055 . hal-03120188

**HAL Id: hal-03120188**

**<https://hal.science/hal-03120188>**

Submitted on 25 Jan 2021

**HAL** is a multi-disciplinary open access archive for the deposit and dissemination of scientific research documents, whether they are published or not. The documents may come from teaching and research institutions in France or abroad, or from public or private research centers.

L'archive ouverte pluridisciplinaire **HAL**, est destinée au dépôt et à la diffusion de documents scientifiques de niveau recherche, publiés ou non, émanant des établissements d'enseignement et de recherche français ou étrangers, des laboratoires publics ou privés.



## Open Archive Toulouse Archive Ouverte



OATAO is an open access repository that collects the work of Toulouse researchers and makes it freely available over the web where possible

This is an author's version published in: <http://oatao.univ-toulouse.fr/27199>

### Official URL:

<https://doi.org/10.1016/j.ifacol.2020.11.055>

### To cite this version:

Tchangani, Ayeley  and Pérès, François  *Modeling interactions for inoperability management: from fault tree analysis (FTA) to dynamic bayesian network (DBN)*. (2020) In: 4th IFAC Workshop on Advanced Maintenance Engineering, Services and Technologies - AMEST 2020, 10 September 2020 - 11 September 2020 (Cambridge, United Kingdom).

Any correspondence concerning this service should be sent to the repository administrator: [tech-oatao@listes-diff.inp-toulouse.fr](mailto:tech-oatao@listes-diff.inp-toulouse.fr)

# Modeling Interactions for Inoperability Management: from Fault Tree Analysis (FTA) to Dynamic Bayesian Network (DBN)

Ayeley Tchangani\* Francois Pères\*\*

\* LGP - Université de Toulouse, 47 Avenue d'Azereix, 65016 Tarbes, France (email: ayeley.tchangani@iut-tarbes.fr)

\*\* LGP - Université de Toulouse, 47 Avenue d'Azereix, 65016 Tarbes, France (email: francois.peres@enit.fr)

**Abstract:** This paper considers the problem of modeling the mechanism of inoperability propagation within a network of complex systems (a production unit, a transportation system, an energy supply system, etc.). We are particularly interested in modeling one of the main attributes of complexity that is *interaction*; indeed, interactions between systems in a network or components in a system have the effect of propagating and perhaps even amplifying local inoperabilities. Two types of interactions are considered: *influence* that can be described by an acyclic hierarchical relationships graph of the interacting systems or components and *interdependence* for which the graphical representation of relationships allows loops. Hierarchy is mainly functional or structural and is analyzed and established in this communication using fault tree analysis (FTA) as the underlying mathematical tools whereas interdependence is apprehended through dynamic Bayesian network (DBN) by considering that effects are delayed. The ultimate DBN model (obtained in two steps: (1) a static Bayesian network (BN) isomorphic to the FTA model and then (2) DBN model by introducing delayed interdependence effects) of a complex system can serve as a decision support system for many risk related scenarios analysis and/or activities such as predictive maintenance.

*Keywords:* Inoperability Propagation, Networked Systems, Risk Assessment and Management, Inoperability Prognostic, Predictive Maintenance, Dynamic Bayesian Network.

## 1. INTRODUCTION

Systems that engineers and scientists are facing today, whether for their modeling, analysis, or management, and in particular for the management of the risks of their dysfunction, are increasingly complex. This complexity is due, among other things, to the need to increase the capacities of these systems by networking them, creating interactions that can lead to unpredictable behavior. Complexity is a word that encompasses a set of concepts whose meaning is highly dependent on the context Gell-Mann (2002), Gold- enfeld and Kadanoff (199), Mainzer (2007). The definition of a complex system varies depending on the discipline to which it applies. The complexity attributes basically addressed in this paper are related to the number of components of a system and principally their interactions that may lead to cascade effect in the case of the failure of one of them. We consider two types of interactions: *influence* and *interdependence*. Influence is materialized by the fact that components interact in hierarchy to form system so that its model can be described by a directed acyclic graph (DAG) whereas interdependence consists in components potentially influencing each other that can be described by a graph where cycles and loops are allowed. In the case of physical systems that are designed and built by man, whose analysis for operational maintenance

procedures is the main subject of this communication, the structure of hierarchy (or interchangeably influence) is rather functional (grouping together the elements of one level to perform a function of another level) whereas the structure of interdependence is physical (exchange of materials, energy, information, friction, etc.). In the field of maintenance, the tools for modeling and analysis of the hierarchy structure are mainly those derived from dependability and, in particular, fault trees analysis (FTA).

FTA is dedicated to analyzing dysfunctional status of a system. Fault tree analysis (FTA), originally developed in 1962 at Bell Laboratories by H.A. Watson, under a U.S. Air Force Ballistics Systems Division contract to evaluate the Minuteman I Intercontinental Ballistic Missile (ICBM) Launch Control System Clifton (1999), is a top down, deductive failure analysis in which an undesired state of a system is analyzed using Boolean logic to combine a series of lower-level events.

This approach can be used for following non exhaustive purposes: understanding the logic leading to the undesired state of a system; showing compliance with the (input) system safety / reliability requirements; prioritizing the contribution of each primary or elementary event or component to the occurrence of the undesired event establishing by the way the criticality of each elementary event;

monitoring and controlling the safety performance of the complex system; minimize and optimize resources; assisting in designing a system; diagnosing and prognosis; etc.

FTA analysis involves following five steps Clifton (1999) going from the definition of the undesired event to study to controlling the identified hazards, through understanding of the system, construction of the fault tree; and evaluating the fault tree.

The use of FTA for modeling the inoperability process of a system has some major flaws:

- the impossibility to take into account the physical interactions between components; components are considered to function independently;
- the states of the components are considered as binary (working or faulty) whereas in practice one can have intermediate states (degraded functioning);
- the difficulty in obtaining numerical indicators of the health status of the system from the health status of the components;
- it is not possible in general to take into account external possible influence on the behavior of the system and/or components;
- etc.

In order to try to remedy these flaws of FTA in order to obtain the models of inoperability of the systems as close to reality as possible, we propose in this paper to proceed in two steps: (1) modeling the hierarchical structure of the system by a fault tree and (2) transforming the model into a dynamic Bayesian network that allows to correct most of the above-mentioned flaws.

The idea of transforming fault trees into Bayesian networks with a view to exploiting their potential to allow a precise analysis of modeled systems is not new in itself. Indeed, there are works in the literature related to this transformation such as Bobbio et al. (2001) which has shown that any fault tree can be transformed into a Bayesian network with the possibility of introducing uncertainty at the level of logic gates; similarly, Montani et al. (2008) has also considered and shown the importance of the relationship between fault trees and Bayesian networks in their work; other related work on this issue is that of Khakzad et al. (2011). What our work tries to bring is that we consider in this paper the integration of the evolution in time of the system and its context of use; moreover the structuring of the transformation process in our work is based on the notions of hierarchy (which can be found in works such as Lanus et al. (2003)) and the interactions leading to three levels in the Bayesian network, namely components level, intermediate level (here the minimal cut sets), and the system level with the possibility of intra - level interdependency; the inter - level dependency being determined by the hierarchy.

## 2. PROPOSED APPROACH

As mentioned above, interactions in terms of influence can be described by a hierarchical structure where the behavior of the basic components influences the behavior of intermediate subsystems to gradually reach the behavior of the overall system. Thus in this section, we will first present the elementary components' structure, then the in-

teraction of these components using fault trees whose final result is the determination of minimum cut sets to finally transform this tree structure into a static Bayesian network by isomorphism. By considering the ageing process of components, delayed effects interdependence between components, and possible influence of external signals, a model in the form of a dynamic Bayesian is obtained as ultimate decision support tool to that can be used for risk informed decision making.

### 2.1 Structure of the system

Structurally, let us consider a system  $S$  in the sense of dependability consisting of  $n$  components given by the set  $C = \{C_1, C_2, \dots, C_n\}$  where each component can be only in two states: either the component is functioning (state OK) or it is not functioning (state OFF). As the purpose of this paper is to study the inoperability of the system, let us define by  $x_i(t)$  the inoperability status of component  $i$  at time instant  $t$  that is binary in this case and given by equation (1)

$$x_i(t) = \begin{cases} 1 & \text{if component } C_i \text{ is OFF at time } t \\ 0 & \text{if component } C_i \text{ is OK at time } t \end{cases}; (1)$$

so that the inoperability status of the overall system can be resumed by its inoperability vector  $x(t)$  as shown by equation (2)

$$x(t) = [x_1(t) \ x_2(t) \ \dots \ x_n(t)]. (2)$$

The ultimate analysis goal is to determine  $\varphi(x(t))$  that represents the inoperability status of the system at time  $t$  defined by equation (3)

$$\varphi(x(t)) = \begin{cases} 1 & \text{if system } S \text{ is OFF at time } t \\ 0 & \text{if system } S \text{ is OK at time } t \end{cases}. (3)$$

To determine this function  $\varphi(x(t))$ , the well indicated mathematical tool is the so called fault tree analysis that is presented in the following.

To analyze the inoperability of the system that is mainly to determining  $\varphi(x(t))$  using FTA analysis, one consider boolean algebra Sikorski (1969) consisting of two operations  $+$  (OR Gate) and  $\bullet$  (AND Gate) so that the physical structure (how basic components states do combine to lead to the state of the system) of the system can be transformed into a tree. From this tree, one can determined the reduced structural functions  $\varphi(x(t))$  that is a valuable information for determining inoperability status of the system. The main results of this analysis are structural or qualitative in terms of *cut sets* (a cut set is a subset of components whose simultaneous failure leads to system failure regardless of the condition of the other components; a cut set is minimal if it does not contain another cut set) and quantitative in terms of probability of inoperability of the system  $I_S(t)$  given actual conditions described by equation (4)

$$I_S(t) = \Pr \{\varphi(x(t)) = 1\}. (4)$$

In terms of prognostics,  $I_S(t)$  is a good indicator to determine for instance the remaining useful life  $RUL^\alpha(t_0)$  at each time instant  $t_0$  at caution or boldness rate  $\alpha$  (probability that the system being operational); indeed by

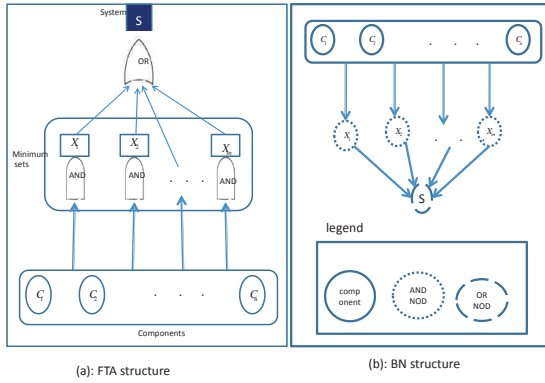

Fig. 1. Representation of the structure of the system by a tree through minimum cut sets (a) and the equivalent Bayesian network (b)

setting up the threshold  $\alpha$ ,  $RUL^\alpha(t_0)$  is given by equation (5)

$$RUL^\alpha(t_0) = I_S^{-1}(1 - \alpha) - t_0 \quad (5)$$

where  $I_S^{-1}(1 - \alpha)$  is the inverse of  $I_S(t)$  defined by (6)

$$I_S^{-1}(1 - \alpha) = \{T : I_S(T) = 1 - \alpha\}; \quad (6)$$

the main challenge therefore is to calculate this indicator  $I_S(t)$ .

Theoretically, it is possible to calculate this function from minimum cut sets; indeed, let us denote by  $X = \{X_1, X_2, \dots, X_m\}$  the set of minimum cut sets obtained from qualitative analysis where  $x_k = [x_{k_1} \ x_{k_2} \ \dots \ x_{k_k}]$  is the vector containing the components of the cut set  $X_k$  and  $\varphi_{X_k}(x_k)$  the indicator of event  $X_k$  happening; therefore  $\varphi_{X_k}(x_k)$  and  $\varphi(x)$  are given by equations (7) and (8) respectively

$$\varphi_{X_k}(x_k) = x_{k_1} \bullet x_{k_2} \bullet \dots \bullet x_{k_k} \quad (7)$$

$$\varphi(x) = \varphi_{X_1}(x_1) + \varphi_{X_2}(x_2) + \dots + \varphi_{X_m}(x_m) \quad (8)$$

that is graphically illustrated by Figure 1 (a).

In theory from equation (8), one can calculate  $I_S(t)$  by using some properties of probabilities theory; but in practice this may be very challenging mainly when the system is constituted by a great number of components and/or if their dynamic behavior is subjected to some external disturbance signals and/or delayed-effect interdependence between components. On other hand, graph of Figure 1 (a) is isomorphic to probabilistic graph known in the literature as Bayesian network and their extension (dynamic Bayesian networks) when one consider for instance ageing process of components and/or influence of external signals.

The advantage of transforming a fault tree or a probability diagram, see for instance Bobbio et al. (2001) and Tchangani (2001), into a Bayesian network is multifaceted: instead of considering binary states to describe the behavior of a system, intermediate states can be introduced to represent, for example, degraded system behaviors; similarly, the probabilities of occurrence can be degraded to simulate a certain level of ignorance. In the perspective

of using Bayesian technology (largely considered in risk management decision making Tchangani (2011)) to model the inoperability of a system with hierarchical interactions, we will briefly recall the principle of dynamic Bayesian networks, the literature on this subject being well provided, and then show how a failure tree can be transformed into a Bayesian network.

## 2.2 Dynamic Bayesian Networks (DBN)

Dynamic Bayesian networks Murphy (2002) derive from an extension of Bayesian networks (see Nielsen and Jensen (2009) Pearl (1988) and references therein) that describe probabilistic relationships between variables of a knowledge domain in order to take into account time behavior. Dynamic Bayesian networks (DBNs) are directed acyclic graphical models of stochastic processes, see [9], and they generalize Hidden Markov Models (HMMs) and Linear Dynamical Systems (LDSs) by representing the hidden and observed state in terms of state variables, which can have complex interdependencies. The graphical structure provides an easy way to specify these conditional interdependencies, and hence to provide a compact parameterization of the model. A dynamic Bayesian networks is completely defined by two components: its structure that is a directed acyclic graph (DAG) where nodes represent variables and directed arcs represents influential relationships between these variables and its parameters that represent conditional probability density (CPD) functions in the case of a continuous variable (the allowed values of the variable belong to a continuous set) or conditional probability table (CPT) in the case of a discrete variable (the allowed values of the variable belong to a discrete set that will be in general a finite set). A dynamic Bayesian network structure consists of an intra slices directed acyclic graph and an inter slices directed graph; slices represent time instants to describe dynamic behavior of the system. Intra slice graph models the instantaneous relationships of nodes (a Bayesian network) and the inter slice graph represents the dynamics of the nodes. Intra slice parameters are conditional probability density functions and/or conditional probability tables of the corresponding Bayesian network and inter slice parameters represent the dynamics of variables on one hand and their relationships with the variables that influence their behavior on the other hand. The advantage of the Bayesian network model over the Markov chain representation for instance, besides the fact that the model is more compact and/or the possibility to consider the influence of the history up to some complexity, is that the transition matrix  $P$  can be learnt (estimated) from the expert knowledge and/or experimental data or parameters depending on external dynamic signals. BN and DBN have been widely used to assist decision making processes in domains such as: dependability, product health management and maintenance, see for instance Liu et al. (2018), Tchangani and Noyes (2006), and references therein. Dynamic Bayesian networks are of particular interest for modeling interactions whose effects are delayed as is usually the case for physical systems. Indeed, in this case the interactions are modeled by the inter-slice relations in the Dynamic Bayesian network while the functional relations form the static Bayesian network at the level of a slice. Of course, the indicators or measures

of importance defined in the safety of operation literature such as those in equations (11) to (15) are easily calculable in a DBN model by running the model.

### 2.3 Transforming a fault tree into a DBN

In this section, we will use dynamic Bayesian networks (DBN) to establish inoperability analysis model of a system which FTA analysis leads to graph of Figure 1 (a); indeed, from this Figure the corresponding Bayesian network structure is given by Figure 1 (b) with three types of nodes as described by the legend, namely nodes representing basic components and intermediate AND and OR combination nodes.

As evoked in the previous section, building a DBN consists in constructing its structure that is straightforward here as the intra-slice structure is isomorphic to the FTA of Figure 1 (a); and establishing its parameters. Specifying these parameters that is conditional probability tables (CPT) for nodes  $X_i$  and  $S$  may be very tedious; indeed if  $X_i$  is constituted of  $n_i$  components the corresponding CPT will have  $2^{n_i}$  lines (in the binary case (ON/OFF)); to overcome this issue and given that each node is homogeneous (either AND or OR), we propose to regroup hierarchically parents by two or three nodes at most to facilitate specifying CPTs. To introduce interdependence relationships, we consider them to be delayed allowing by the way the possibility of modeling loops in interactions, taking into account ageing process of components, and possible influence of external signals. Though the range of historical effect on actual behavior of the system may be very long, when observations are made on small sample time (what is not a hard constraint), one can considered this range to be reduced. In terms of DBN, we consider therefore a two slices DBN model as shown by Figure 2 where arcs with  $t-1$  denote delayed effect: inner such arcs correspond to auto-influence (ageing process for instance) of components whereas arc on the cluster represent delayed effects of other components; external signal  $w(t)$  is supposed to have an instantaneous effect but it could have its own dynamics that can be taken into account in this model. Quantitatively, interdependence between a components  $i$  and other components as well as its environment is summarized by its transition matrix  $P_i(t)$  at time  $t$  given by equation (9)

$$P_i(t) = Pr\{x_i(t)/x(t-1), w(t)\} \quad (9)$$

By so doing the corresponding dynamic Bayesian network model that can be implemented using existing software packages such as Netica Netica (2019), BayesiaLab BayesiaLab (2019), Hugin Expert Hugin (2019), etc. or by writing ones own code to deduce the  $I_S(t)$  of the system is given by Figure 2 where dotted loops over components denote dynamic behavior of states of these components between two consecutive time slices to represent their ageing process and  $w(t)$  is a possible external disturbance signals that may affect components.

By running the DBN of Figure 2, one will not only determine  $I_S(t)$  that can be used to determine the  $RUL$  of the system, but many other indicators useful for diagnosis, predictive maintenance, risk analysis, etc. such as the following ones known as importance factors in dependability literature Limmios (2005).

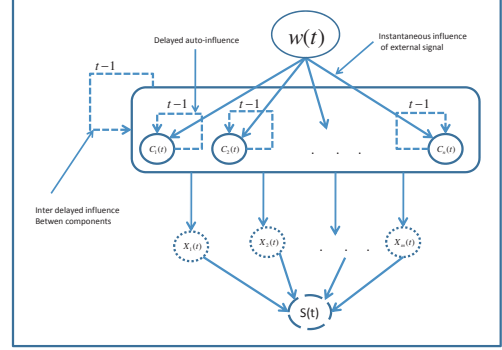

Fig. 2. Two time slices model of BN of Figure 1 (b)

- Criticality of a component: a vector  $x(t)$  is critical at time  $t$  for component  $C_i$  if it verifies equation (10)

$$\varphi((1_i, x(t))) = 1 \text{ and } \varphi((0_i, x(t))) = 0 \quad (10)$$

where  $(x_i, x(t))$  means that the component  $C_i$  is in its status  $x$  (0 or 1) at time  $t$ . It means that if component  $C_i$  is inoperable at time instant  $t$  then the system will be inoperable and if it is functioning the system will be functioning.

- Risk augmentation factor  $RAF_i(t)$  of component  $i$ : relative increase of the probability of inoperability of the system knowing that the basic component  $C_i$  is inoperable given by equation (11)

$$RAF_i(t) = \frac{I_{S/x_i(t)=1}(t) - I_S(t)}{I_S(t)} \quad (11)$$

where  $I_{S/x_i(t)=1}$  is the probability of inoperability of the system given that the component  $C_i$  is totally inoperable.

- Risk diminution factor  $RDF_i(t)$  of component  $i$ : relative decrease of the probability of inoperability of the system knowing that the component  $C_i$  is operating given by following equation (12)

$$RDF_i(t) = \frac{I_S(t) - I_{S/x_i(t)=0}(t)}{I_S(t)} \quad (12)$$

where  $I_{S/x_i(t)=0}$  is the probability of inoperability of the system given that the component  $C_i$  is totally operable.

- Vessely-Fussell or diagnosis importance factor  $VF_i(t)$  of component  $i$ : probability that the basic component  $C_i$  is inoperable knowing that the system is inoperable defined by equation (13)

$$VF_i(t) = Pr\{x_i(t) = 1/\varphi(x(t)) = 1\} \quad (13)$$

- Birnbaum's factor  $BF_i(t)$  of component  $i$ : probability that vector  $x(t)$  is critical for component  $C_i$  at time instant  $t$  defined by (14)

$$BF_i(t) = I_{S/x_i(t)=1}(t) - I_{S/x_i(t)=0}(t) \quad (14)$$

- Lambert or critical component factor  $LF_i(t)$  (diagnosis) of component  $i$ : probability that the vector  $x(t)$  is critical for component  $C_i$  and the system is inoperable or the probability that the inoperability of component  $C_i$  is the cause of the inoperability of the system that is given by equation (15)

$$LF_i(t) = \Psi_i(t) Pr\{x_i(t) = 1\} \quad (15)$$

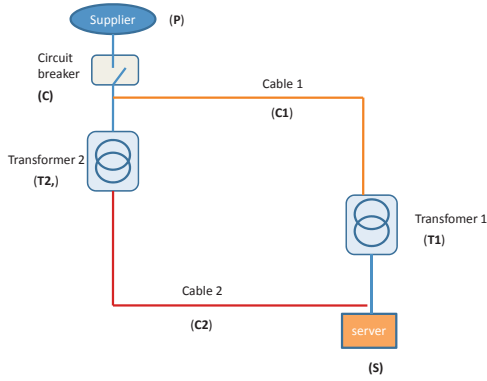

Fig. 3. Scheme of illustrative case study

where  $\Psi_i(t)$  is given by (16)

$$\Psi_i(t) = \left( \frac{I_{S/x_i(t)=1}(t) - I_{S/x_i(t)=0}(t)}{I_S(t)} \right) \quad (16)$$

In the following section, we will illustrate the approach described in the previous sections on a case study system that is primarily intended to be pedagogical. The reader will have noted that the simplicity of this illustrative example does not prevent the approach from being applied to real world application cases.

#### 2.4 Illustrative case study

Consider a power supply system for a server consisting of a power supplier (P), a circuit breaker (C) and two parallel circuits (active redundancy) each consisting of a cable (C1/2) and a transformer (T1/2) as shown in Figure 3.

The main objective is to model this system in order to prognosis the possibility of inoperability of the server due to a lack of electrical energy. FTA analysis of this system (giving the fault tree as that of Figure 1 does not bring anything significant here) leads to 6 minimal cut sets: two of order 1 (the number of elements in the cut set) in terms of  $P$  (main power supplier) and  $C$  (circuit brcker) and four of order 2 consisting in  $T1T2$  (transformers),  $T1C2$  (transformer 1 and cable 2),  $T2C1$  (transformer 2 and cable 1) and finally  $C1C2$  (cables).

Let us consider the following dynamic scenario: it is admitted that nominal failure rate of all components are considered to be  $\lambda_i^0 = 10^{-3}/TU$  where TU stands for time unit; but the real failure rate of the two transformers depend on a time varying disturbance signal  $w(t)$ , with a nominal value  $w_0$ , according to the law given by equation (17)

$$\lambda_{T_i}(t) = \lambda_{T_i}(t-1) + \beta_{T_i}(w(t) - w_0), \quad \lambda_{T_i}(0) = \lambda_i^0 \quad (17)$$

and the main purpose is to study the influence of this signal on the  $I_S(t)$  of the system. Dynamic Bayesian Network model of this system is shown on Figure 4 where  $S(t)$  represents the status of whether the server is supplied of power or not.

Let us denote by  $RUL_{w_0}^\alpha(t_0)$  and  $RUL_{w(t)}^\alpha(t_0)$  the remaining useful life from time instant  $t_0$  at the caution

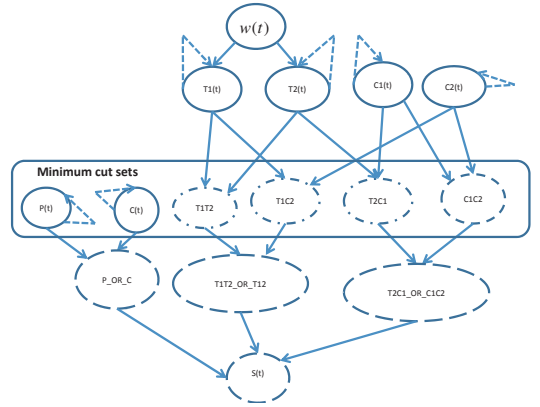

Fig. 4. Dynamic Bayesian network model of considered illustrative application

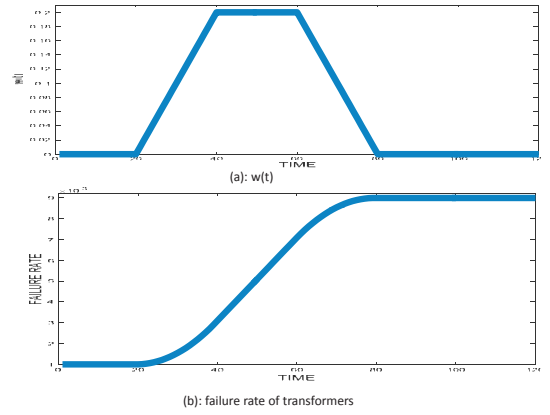

Fig. 5. Simulated behavior of external signal  $w(t)$  and transformers failure rate

or boldness index  $\alpha$  in nominal behavior of the external signal ( $w_0$ ) and when transformers are subjected to external signal  $w(t)$  respectively. Consider now the following conditions:

- nominal behavior of external signal is  $w_0 = 0$ ;
- $w(t)$  and consequently  $\lambda_{T_i}(t)$  behave like the curve shown on Figure 5 (a) and Figure 5 (b) with  $\beta_{T_i} = 10^{-3}$ .

By running the DBN model given by Figure 4, we obtain result shown on Figure 6 for  $I_S(t)$  where the red curve corresponds to perturbed case whereas the blue one corresponds to nominal behavior of external disturbance signal  $w(t)$ .

From this Figure 6 we can see that at caution or boldness index of  $\alpha = 10\%$ , the nominal and the disturbed RULs at time instant  $t_0 = 20$  are given by  $RUL_{w_0}^{0.1}(20) \approx 750 - 20 = 730 TU$  and  $RUL_{w(t)}^{0.1}(20) \approx 250 - 20 = 230 TU$ . In terms of decision making, given the behavior of external signal  $w(t)$ , decision maker can either maintain the caution or boldness level of 10% and then shorten the mission time from 730 to 230 or maintain the mission time of 730 by diminishing the caution from 10% to almost 0%.

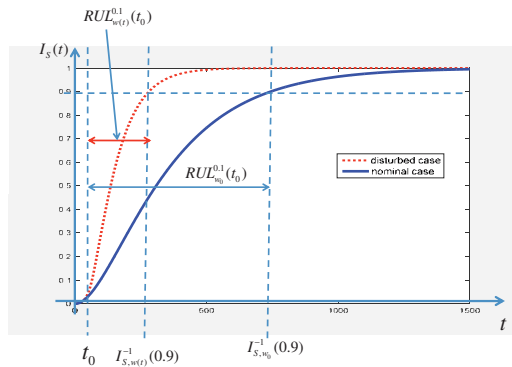

Fig. 6. Results obtained by running the DBN model for the considered scenario

### 3. CONCLUSION

A problem of modeling complex systems in order to analyze and manage risk related to their inoperability has been considered in this communication. Two main attributes of complexity has been addressed, namely hierarchy and interdependence. Basically, hierarchy is considered through directed acyclic graph (DAG) to represent functional relationship between components of the systems whereas interdependence is considered to represent delayed inter-relationship effect between components. Thus, modeling process goes from functional or dysfunctional analysis using fault tree analysis (FTA) as the underlying mathematical tool to obtain structural model representing functional or organizational description of the system; then this FTA model that is isomorphic to Bayesian network (BN) is transformed to a dynamic Bayesian network (DBN) to taken into account delayed interdependence effect. The ultimate DBN model can serve as a decision support system for many decision making as it permits to simulate different scenarios, to estimate many indicators related to inoperating status of the system. Future works will be devoted to applying this approach to real world problems. The apparent difficulty in moving to a scale of application on real systems of the approach set out in this paper lies in the complexity of constructing the dynamic Bayesian network and defining its parameters. However, the structuring adopted in this paper, namely a functional hierarchy and delayed-effect interdependency, makes it possible to envisage the construction of the model by modules.

### REFERENCES

BayesiaLab: <http://www.bayesia.com/>  
 Bobbio, A., Portinale, L., Minichino, M., and Ciancamerla, E. (2001). Improving the analysis of dependable systems by mapping fault trees into Bayesian networks. *Reliability Engineering & System Safety*, 71(3), 249-260.  
 Clifton E. (1999). *Fault Tree Analysis - A History*. Proceedings of the 17th International Systems Safety Conference, 1999.  
 Gell-Mann M. (2002). What is complexity, *Complexity and industrial clusters*, 13-12, Springer.

Goldenfeld N., Kadanoff L.P. (1999). Simple lessons from complexity science, 284(15411): 87-3.  
 Haimes, Y., Horowitz, B., Lambert, J., Santos, J. R., Lian, C., and Crowther, K. (2005). Inoperability Input-Output Model for Interdependent Infrastructure Sectors. I: Theory and Methodology, *Journal of Infrastructure Systems*, 11 (2): 67-13.  
 Hugin: <https://www.hugin.com/>  
 Khakzad, N., Khan, F., & Amyotte, P. (2011). Safety analysis in process facilities: Comparison of fault tree and Bayesian network approaches. *Reliability Engineering & System Safety*, 96(8), 925-932.  
 Lanus, M., Yin, L., and Trivedi, K. S. (2003). Hierarchical composition and aggregation of state-based availability and performability models. *IEEE Transactions on Reliability*, 52(1), 44-52.  
 Limnios N. (2005). *Arbres de défaillance*. Herms-Lavoisier.  
 Liu Q., Tchangani A., Pérès F., Gonzalez-Prida V. (2018). Object Oriented Bayesian Network for complex system risk assessment Proceedings of the Institution of Mechanical Engineers, Part O: Journal of Risk and Reliability, 232 (4): 340-351.  
 Mainzer K. *Thinking in complexity: The computational dynamics of matter, mind, and mankind*, Springer Science & Business Media, 2007.  
 Montani, S., Portinale, L., Bobbio, A., and Codetta-Raiteri, D. (2008). Radyban: A tool for reliability analysis of dynamic fault trees through conversion into dynamic Bayesian networks. *Reliability Engineering & System Safety*, 93(7), 922-932.  
 Murphy KP. (2002). *Dynamic bayesian networks: representation, inference and learning*. PhD Thesis, University of California, Berkeley.  
 Netica: <https://www.norsys.com/netica.html>  
 Nielsen TD., Jensen FV. (2009). *Bayesian networks and decision graphs*. Springer Science & Business Media.  
 Pearl J. (1988). *Probabilistic reasoning in intelligent systems: networks of plausible inference*, Morgan Kaufmann.  
 Santos, J. R. (2006). Inoperability Input-Output Modeling of Disruptions to Interdependent Economic System, *Systems Engineering*, 9 (1): 20-15.  
 Sikorski R. (1969). *Boolean Algebras* (3/e ed.) Berlin: Springer-Verlag, ISBN 978-0-387-04469-9.  
 Tchangani A. P. (2017). Modelling Inoperability Propagation Mechanism in Interdependent Systems, Proceedings of 4<sup>th</sup> IEEE International Conference on Control, Decision and Information Technology; CoDIT'17: 18-6, IEEE Xplore.  
 Tchangani A.P. (2015). Integrating Human Attitude in Risk Assessment Process, *Journal of Uncertain Systems*, 9 (3): 175-8.  
 Tchangani A.P. (2011). A Model to support Risk Management Decision-Making, *Studies in Informatics & Control Journal* 20: 3. 209-220.  
 Tchangani A.P., Noyes D. (2006). Modeling Dynamic Reliability using Dynamic Bayesian Networks *Journal Européen des Systèmes Automatisés*, 40(8): 911-25.  
 Tchangani A.P. (2001). Reliability Analysis using Bayesian Networks, *Studies in Informatics & Control Journal* 10: 3. 181-188.  
 Weng G., Bhalla U.S., Iyengar R. (1999). Complexity in biological signaling systems *Science*, 284 (15411): 92-5.