



HAL
open science

Influence of operation mode of a drop-feed-pellet domestic boiler on gaseous and particulate emissions

Angel Alfonso Martinez Martinez, Corine Lacour, Jérôme Yon, Alexis Coppalle

► To cite this version:

Angel Alfonso Martinez Martinez, Corine Lacour, Jérôme Yon, Alexis Coppalle. Influence of operation mode of a drop-feed-pellet domestic boiler on gaseous and particulate emissions. INFUB-12: 12th European Conference on Industrial Furnaces and Boilers, Nov 2020, Porto, Portugal. hal-03117136

HAL Id: hal-03117136

<https://hal.science/hal-03117136v1>

Submitted on 20 Jan 2021

HAL is a multi-disciplinary open access archive for the deposit and dissemination of scientific research documents, whether they are published or not. The documents may come from teaching and research institutions in France or abroad, or from public or private research centers.

L'archive ouverte pluridisciplinaire **HAL**, est destinée au dépôt et à la diffusion de documents scientifiques de niveau recherche, publiés ou non, émanant des établissements d'enseignement et de recherche français ou étrangers, des laboratoires publics ou privés.

Influence of operation mode of a drop-feed-pellet domestic boiler on gaseous and particulate emissions

Martinez Angel, Lacour Corine, Yon Jérôme, Coppalle Alexis

martinea@coria.fr

Normandie University, INSA Rouen, UNIROUEN, CNRS, CORIA, 76000 Rouen, France

Abstract

Wood pellet combustion as source of energy is increasingly used in Europe [14]. However, heating appliances such as wood pellet boiler relies on combustion processes and, consequently, are responsible for emissions, which could negatively affect the human health and the global warming [15]. The emissions of pellet boilers are influenced by the mode of feeding and operational characteristics of the combustion. The goal of this study is to investigate the influence of the feeding mode on the quality of the emissions in particular soot and ashes. Two feeding operating conditions are considered (pulsed and continuous alimentation) in a drop-feed-pellet boiler (20kW). Gaseous and particulate emissions were sampled at the vicinity of the boiler outlet. Monitoring of the emission of gaseous pollutants (CO, NO_x) has been done, measurement of particles emissions is ensured by a Pegasor Particle Sensor (PPS) system. The mass concentration of particles is measured with a micro-balance TEOM and the soot particle sizes with a Scanning Mobility Particle Sizer (SMPS). Results show an increase of the carbon monoxide emissions for pulsed feeding mode between 500-900 ppm, whereas the maximum peaks observed for the continuous feeding were 100-200 ppm. In addition, the soots size ranges between 50-60 nm for all the operating modes. We also investigated the use of the PPS system for the monitoring of particles emission during the boiler running. This apparatus enables a time resolved evaluation of PM emission. Nevertheless, a coefficient is needed to convert the measured current in mass concentrations. In the present work, that coefficient has been determined by comparing the exact mass concentration with the micro-balance (TEOM) to the value given by the PPS. It appears that the calibration of the PPS is requisite when changing the fuel composition.

Introduction

Nowadays, the use of biomass for domestic purpose, like water heating and building heating is increasing. In the same time, the quantity of scientific investigations and the financial incentives for the acquisition of this kind of heating systems are also increasing. Currently, this market is already well known in some countries of Europe [1]. Usually, the pellets boilers use wood derived fuel, because of the limited availability of other natures of biomass for energy purposes [2]. Due to the high pressure on the forest resources that some industrial sectors are applying, it is more and more important to improve the performance of this kind of technologies to assure the best use of the raw materials [3]. In addition, it is important to improve these combustion processes, because with their increasing use, pollutant emissions also increase [4]. In previous works, the influence in the feeding mode is shown for the emissions of CO [5,6]. It is also shown that the characteristics of the boiler, the fuel properties and the operating conditions affect significantly the combustion process and the pollutant emissions. The emissions from incomplete pellets combustion, in particular CO and unburned hydrocarbons (HC), can be reduced when combustion conditions promote the oxidation of products. Mixing limitations and low temperatures inhibit oxidation and lead to increased emissions of CO [7]. Disturbances of the fuel bed, occurring during intermittent operation and in top-fed burners, deteriorate combustion conditions temporarily, leading to peaks of CO and HC emissions [7]. In small domestic boilers, the temperature in the combustion chamber is typically below 1300°C and, therefore, NO formation via the fuel mechanism is expected to be the main source of NO_x emissions [8]. It is well established that NO_x emissions are strongly dependent of the fuel nitrogen content, confirming the importance of the fuel-NO mechanism [8]. But, the operating conditions in the chamber can affect directly the emissions of NO because of the turbulence or temperature.

For the present study, we use a domestic boiler of 20 kW nominal thermal power, and different feeding modes are imposed to analyse the consequences in term of pollutant emissions. For the sampling in the exhaust smokes, a Fine Particle Sampler (FPS) is used to ease the sampling and dilution procedure.

For the gases measurements a TESTO analyser equipped with electrochemical cells is used. Particles emissions are continuously monitored by means of a PPS. However, the PPS does not measure directly the particle content in the smoke and need to be calibrated with a microbalance TEOM. The main objective of the present article is to evaluate the impact of the feeding mode on CO and particle emission in the smokes. To accomplish this goal, the performance of a domestic top-feed boiler with pulsed and continuous feeding is investigated

1. Experimental equipment

1.1 Biomass used

Commercial pellets according to the norm DIN plus are used as biomass fuel. An elemental analysis is performed to know the concentration of the principal elements in the pellet (C, H) and the values for the other elements (S, Cl, N) have been taken from the DIN standards [10]. The characteristics of the pellets are given in the table 1. One can see that our values for H and C are close to others authors values [11,12]. For the moisture, we use a process according to the standard UNE-EN 14774-2 and our values are in the range of DIN Standards [10]. The concentration of other elements than C, H and O are small. If the concentration values of all others elements than C and H are neglected, O concentration is equal to 47.61%.

Table 1. Physical and chemical characteristics of the pellet.

Diameter	6mm±1	N	≤0.3%
Length	3.15-40mm	S	≤0.03%
Moisture	6%	Cl	≤0.02%
Ashes	≤0.7%	C	46.68%
Mechanical resistance	≥97.5%	H	5.71%
Quantity of fines	≤1%		
Additives	≤2%		
PCI	4.6-5.3 kWh/kg		
Density	≤1200 kg/m ³		
Origin	Wood		

1.2 Experimental setup

A schematic of the test system is presented in fig 1, the boiler has a nominal thermal capacity of 20kW. The pellets are manually loaded into a hopper and are fed through a screw feeder working in 2 different ways, by impulses or continuously. Calibration of the screw feeder has been performed in order to determinate the pellet consumption rate, for both regimes. The boiler operates with a reduced pressure and a natural aspiration of air inlet.

The heated water in the boiler is cooled down in a plate-heat-exchanger with an external water circuit. As shown in fig 1, VT-1 is a 3-way valve and is used to adjust and regulate the water temperature at the entrance of the boiler. The temperature is adjusted by mixing the hot water coming out of the boiler and the chilled water from the heat exchanger. This water entrance temperature is critical for the regulation of the system and the operating performance of the boiler. The P-1 is a line pump that can be regulated in 3 different flows. The water flow rates is measured by means of magnetic rotameters (D-1,D-2), enabling to perform a full heat balance of the system.

In the boiler circuit, the inlet and the outlet water temperatures are measured with T5 and T6 thermocouples and in the heat exchanger with T1 and T2. All these thermocouples were K-type with 1 mm in probe diameter. The combustion chamber is also equipped with a 0.25 mm K-type thermocouple to monitor the temperature changes with a faster time response. A K-type thermocouple is placed in the flue-gas exhaust duct. The analog outputs of the thermocouples and flowmeters were transmitted via an A/D board to a computer using a National Instrument board, where the signals are processed and the mean values are computed over 1 s sampling periods.

The dimensions of the combustion chamber of the boiler are $15 \times 15 \times 15 \text{ cm}^3$. The pellets are fed in a pellet-drop-feed way. The igniter is an electrical resistance located close to the centre base of the combustion chamber, where the air is admitted through orifices in the 4 sides of the chamber.

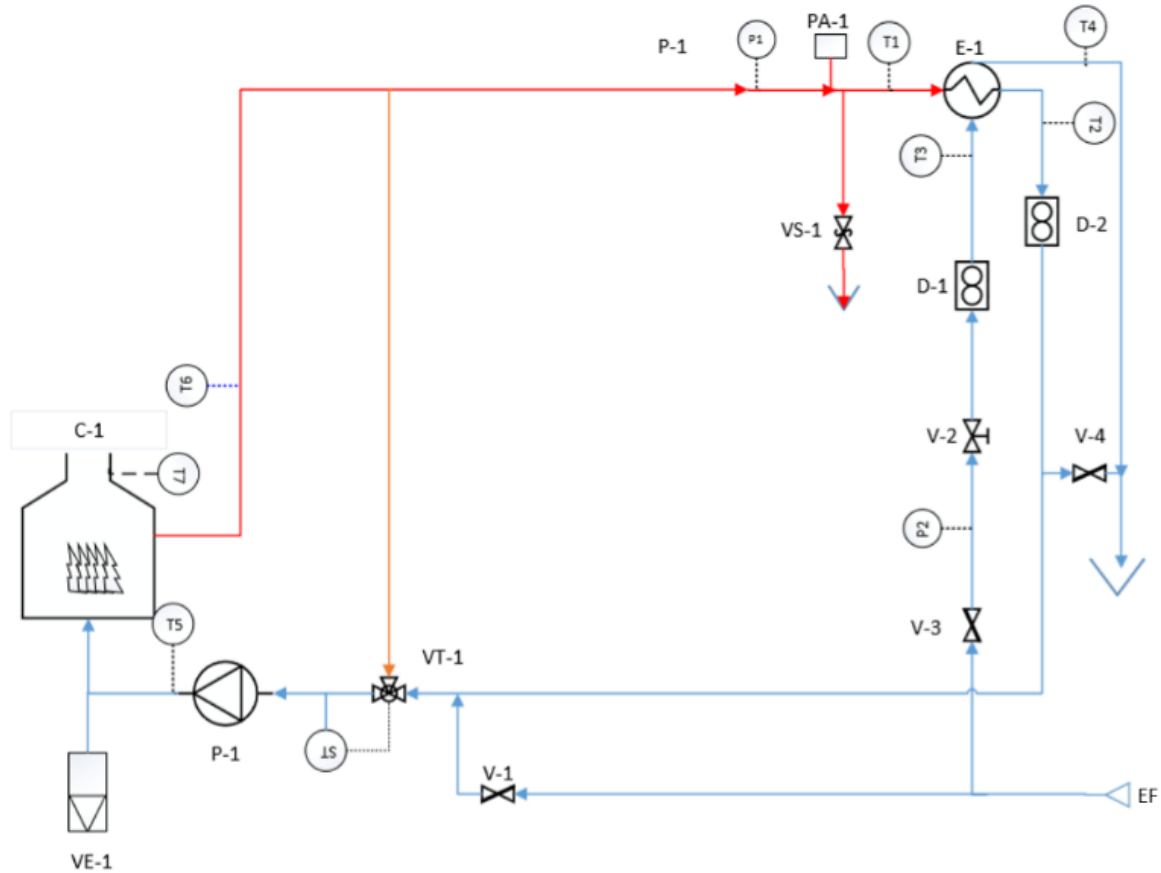

Figure 1. Experimental Setup Diagram.

1.3. Particle and gas sampling in the chimney

The analysis is focused on the pollutant emissions. The boiler flue gas samples are extracted in the boiler chimney just after the extractor and gas and particle concentrations are measured. The boiler flue-gas composition is continuously monitored during the boiler operation in order to evidence any change in its operating conditions. The sampling of flue-gas for measurement of O_2 , CO_2 , CO , and NO_x concentration was achieved using a TESTO 350 device. The analysis of the concentrations is performed on a dry basis.

For the particle sampling, a Fine Particle Sampler (FPS, Dekati manufacturer) was used (fig.2). It is a versatile solution for diluting and conditioning aerosol samples for measurement instruments. His two-stage dilution system allows dilution factor adjustment between 1:20 and 1:200. The head of the probe can be heated and samples can be taken at high temperatures (up to 350°C) and at atmospheric pressure. For the present study, the head is heated at 200°C for avoiding the condensation of heavy condensable hydrocarbons. Thus, the dilution is performed for samples at high temperature which allows to avoid the dew point of condensable gases to be reached. The influence of the temperature head of the probe on the results is investigated. In fig 3, the comparison between a heated and a cool heads is presented, the difference could be due to the effect of the condensation though the probe and before the samples reach the measurement facility. With a heated head, there is less condensation and a higher concentration is observed.

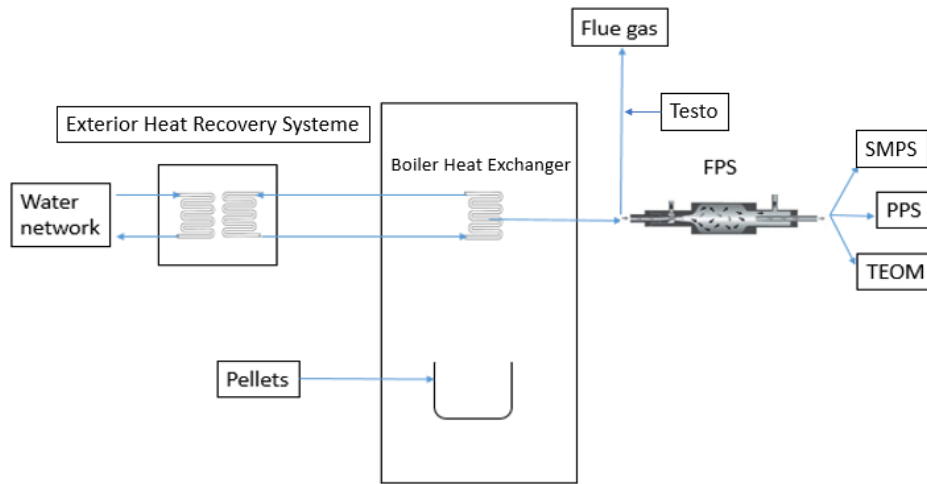

Figure 2. Layout of measurement equipments.

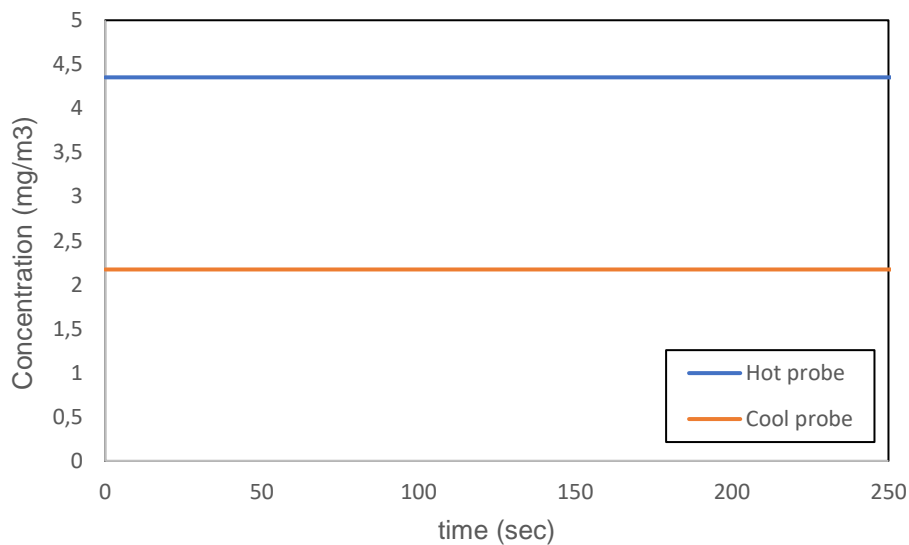

Figure 3. Influence of probe heating in the particle concentration (dilution factor 12 for both experiments, TEOM measurements, continuous mode).

1.4. Particle measurements

Particles concentration is measured by means of a Pegasor Particle Sensor system (PPS, Pegasor manufacturer) which allows to follow continuously the variation of particulate matter concentration thanks to its fast time response. The principle of PPS is based on the electrical detection of aerosol following the “escaping current” technique, which was first described by Lehtimäki [13]. A sample of the smoke is charged by a corona-ionized flow and is pumped by an ejector diluter. While the majority of the corona ions return to the grounded body of the sensor due to their high electrical mobility, a small quantity is lost with the charged particles exiting the sensor. This “escaping current” is used as a measure of the particle concentration in the exhaust gas. The Pegasor particle sensor has thus to be calibrated. This has been done with both total particle mass and total particle number concentration by The Laboratory of Applied Thermodynamics in Thessaloniki Greece (LAT), on the exhausts of car engines and in fossil fuel smokes. For the present study, the PPS has been used in the gas exhaust of the biomass boiler, the nature of the particle and the corona discharge are suspected to be different from previous studies, the calibration has thus been done again. For that, we use a Tapered Element Oscillating Microbalance (TEOM), which is an instrument used for measuring the particle mass concentration. It makes use of a small vibrating filter whose oscillation frequency changes when aerosol particles are

deposited on it, increasing its inertia [16]. TEOM-based devices have been approved by the U.S. Environmental Protection Agency for environmental air quality monitoring, and by the U.S. Mine Safety and Health Administration for monitoring coal dust exposure for miners to prevent several respiratory diseases.

2. Results and discussion

2.1. Calibration of the PPS

The following equation gives the concentration calculated with the current I detected by the PPS:

$$Cs = \frac{1}{16,666} \frac{K}{qv} I$$

Where:

Cs= Particles concentration.

qv= Flow through the pps.

I= Currant measured in PPS

K= Calibration Constant

As explained above, K is a constant which has been first calibrated for internal combustion engine operations. The constant need thus to be specifically determined for the use in biomass combustion smokes. The figure 4 shows an example of TEOM measurement during 140 seconds, and the corresponding PPS signal.

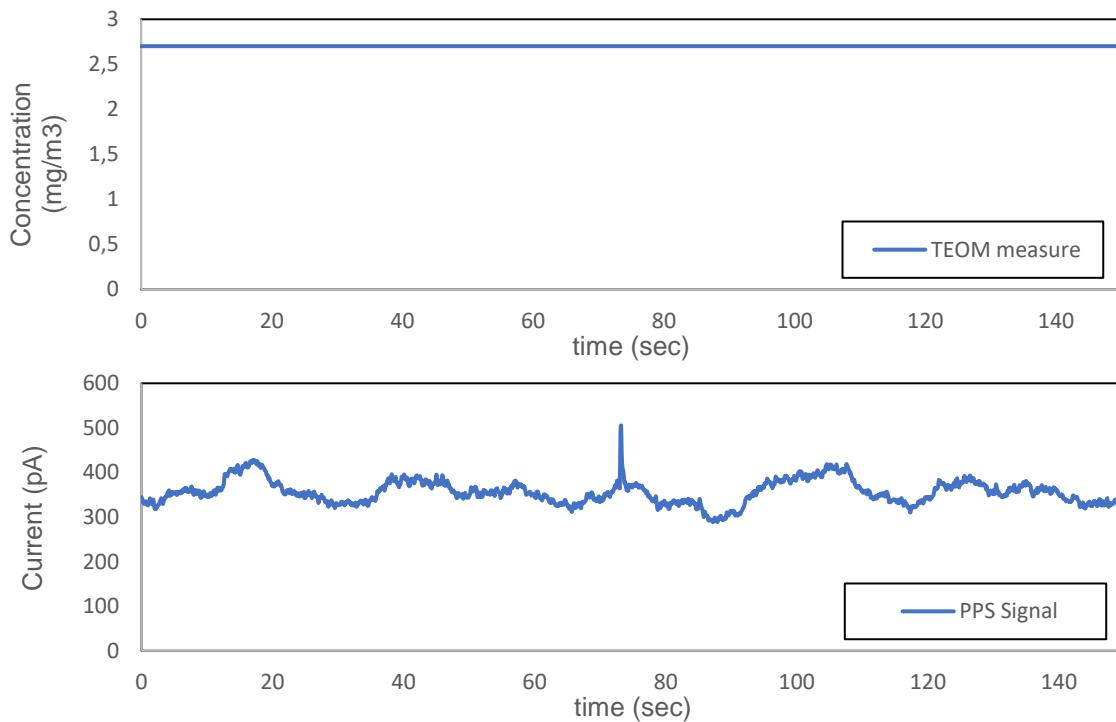

Figure 4. Example of values of mass concentration provided by the TEOM and the current delivered by the PPS.

As seen in fig. 4, there is more variations in the signal delivered by the PPS. This must not be interpreted as a noise in the current signal. Most of the variations are due to the fast response of the PPS compared to the TEOM, which response time is about several second. A series of experiments has been performed to determinate a mean K value, and the results are reported in the table 2.

Table 2. Measure series used for the calibration of the PPS and values of K.

Experiment	TEOM	PPS	flow rate in PPS	K
	[mg/m ³]	[pA]	[L/min]	
1	2,83	365,4	5,69	0,73
2	2,431	359,157	5,69	0,64
3	2,633	384,209	5,69	0,65
4	2,842	346,242	5,69	0,78
5	2,889	368,307	5,69	0,74
6	2,59	380,457	5,69	0,65
7	2,659	386,7	5,69	0,65
8	2,905	396,519	5,69	0,69
			mean	0,70

The values provided by the constructor are function of the diameter of the particles. For a diameter close to 100 nm they give a $K=2.5$. We can see a significant difference of the value given by the constructor $K=2.5$ and the value obtained in this work $K=0.7$. This can be explained by the specific nature of the particles present at the exhaust of the biomass boiler. Large quantities of ashes are present, changing the electrical property of the aerosols and the corona discharge may have a different effect on the biomass particles compared to soot that are mainly black carbon. As presented in fig 3, the temperature of the probe has an important influence on the measured aerosol concentration. Thus, a constant temperature of 200°C of the probe is ensured to avoid any condensation that would lead to errors in the evaluation of the calibration factor K.

2.2 Influence of feeding mode

The boiler can operate with two feeding methods, pulsed and continuously. For the “pulsed” mode, the feeding screw operates with cycles of 10 seconds, for example if 80 %of the nominal power is required, the feeding system is running for 8 seconds and stop for 2 seconds. For the “continuous” mode, the velocity of rotation for the endless screw is reduced in order to reach 80% of the nominal power. Using the two feeding methods (pulsed and continuous), the comparison was made for the same power fixed to 14kW, corresponding to the 80% of maximal nominal power of the boiler. The operation parameters for the two methods of feeding are presented in the table 3.

Table 3. Experimental conditions for the two feeding modes at 80% of the nominal power of the boiler and at 100% in the continuous mode.

Temperature	Continuous 80%	Pulsed 80%	Continuous 100%
T1 (°C)	61.88	61.99	60.33
T2 (°C)	19.55	19.60	23.83
T3 (°C)	16.52	16.53	14.70
T4 (°C)	31.18	31.12	40.89
T5 (°C)	54.30	54.21	51.23
T6 (°C)	61.59	62.05	60.35
T7 (°C)	149.22	150.57	146.37
Chamber temperature (°C)	847.6	844.3	870.2
Power U (kW)	14.70	14.64	17.55
Efficiency	0.65	0.63	0.71

In the table 3, the efficiency of the boiler is defined as the ratio between the power available for the water circuit and the power given by the pellet combustion (PCI, table 1). We can see that for the same 80%

power, under pulsed and continuous feeding modes, the efficiency is similar. But, it should be noted that for the pulsed feeding, the pellets are provided 8 seconds during the cycle of ten seconds, that means that the feeding is not so far from the continuous mode. For comparison, the values obtained for a continuous mode with 100% of the nominal power are presented in Table 3. The temperatures measured in the combustion chamber are close to 850°C for all operating conditions presented, ensuring that the variations in NOx or CO levels are not induced by temperature conditions in the furnace.

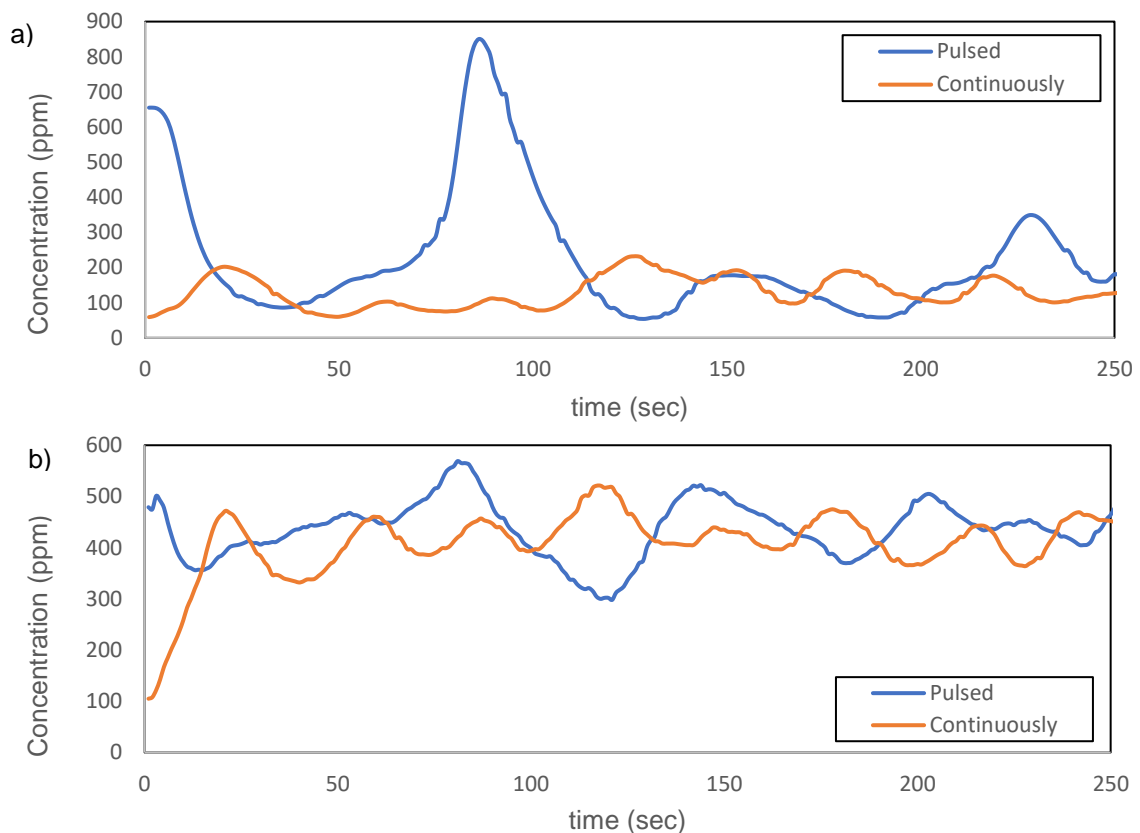

Figure 5. Pulsed and continuous modes at 70% of the nominal power of the boiler: a) PPM of CO b) PPM of NOx.

In the figure 5, the CO and NOx emissions are presented for the two feeding modes. The CO emissions present a significant variability with the pulsed mode compared to the 'continuous' mode, as observed in [7]. Carbon monoxide emissions are ranged between 100 to 900 ppm for pulsed feeding mode with peaks reaching 500-900 ppm, whereas the maximum peaks observed for the continuous feeding were 100-200 ppm. Concerning the NOx emissions, they do not present important differences between the two feeding modes.

In the figure 6 a) and b), the concentration and size of particles are presented for the two modes. Particles diameters have been measured with the FPS probe with a dilution of 38 and a probe temperature of 200°C. The figure 6 a) presents the variations of the particle concentrations as a function of time. The feeding mode does not have a strong influence on the mass concentration of particles. The diameter of particles is also very close for the two feeding modes. Its order of magnitude is about 50 nm, a small value in comparison with the value encountered in the exhaust of diesel engine or in flame of gas combustibles like methane or propane.

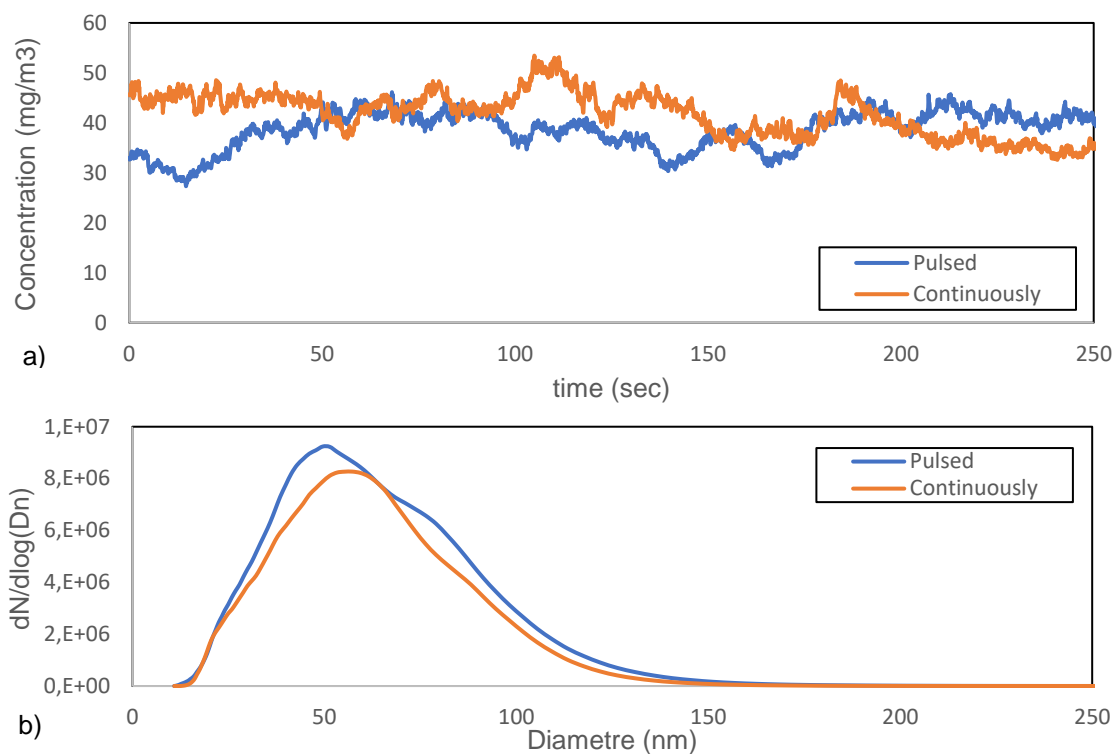

Figure 6. Pulsed and continuous modes at 70% of the nominal power of the boiler: a) mass particle concentrations b) Particle diameter distributions.

3. Conclusions

The influence of the feeding mode (pulsed and continuous) on gaseous and particulate emissions has been investigated in a drop-feed-pellet boiler (20kW). Results show an increase of the carbon monoxide emissions for pulsed feeding mode between 100-900 ppm, with significant peaks, whereas the maximum peaks observed for the continuous feeding only reach 100-200 ppm, with a weak standard deviation. The present results are comparable with results presented by Qiu [9]. The author used a boiler with the same nominal power (20 kW), but with a down-feeding furnace. The comparison of the present results and results presented by Qiu, show that operating in drop-feed pulsed mode produces more fluctuations in CO levels than a down-feed mode. Higher CO levels can be explained in the drop-feed configuration, due to an alteration of the pellets bed by the regular drop of fresh pellets joining the burning bed. In pulsed mode, the feeding is not regular and sometimes fuel bed collapses on itself. On the other hand, we can observe that for the drop-feed continuous mode, the fluctuations are less important because this feeding mode is closer to the down-feed pellets mode.

Concerning the NO_x emissions, the present results show that emission levels are similar for the two feeding modes (pulsed and continuously). The temperature measured into the combustion chamber is very close for the two cases (Table 3) and as the NO_x emissions are very sensitive to the furnace and flame temperatures, this should contribute to explain the similarity in NO_x levels[8]. It should also be noted that Qiu presents lower NO_x levels thanks to air staging implemented in his set-up [9]

As far as particles emissions are concerned, their concentration levels are equivalent for both feeding modes. Moreover, no significant fluctuations are observed, unlike for CO emissions. Mean particles emissions measured in the present study are weaker than the levels reported in the literature [9]. Further investigations are needed to understand the behaviour of particle emissions, and particularly for the temperature variations.

Finally, this contribution pointed out the need for a dedicated calibration for PPS measurement. Indeed, the results show that the effect of the nature of the particles is of particular importance in the determination of the factor K. This is attributed to the fact that the electrical properties of the corona discharge may change with particles of different composition. A new value of K factor is proposed here for particle concentration measurement with biomass fuel.

5. References

- [1] Verma, V. K., Bram, S., & De Ruyck, J. (2009). Small scale biomass heating systems: standards, quality labelling and market driving factors—an EU outlook. *Biomass and bioenergy*, 33(10), 1393-1402.
- [2] Verma, V. K., Bram, S., Gauthier, G., & De Ruyck, J. (2011). Evaluation of the performance of a multi-fuel domestic boiler with respect to the existing European standard and quality labels: Part-1. *Biomass and Bioenergy*, 35(1), 80-89.
- [3] Selkimäki, M., Mola-Yudego, B., Röser, D., Prinz, R., & Sikanen, L. (2010). Present and future trends in pellet markets, raw materials, and supply logistics in Sweden and Finland. *Renewable and Sustainable Energy Reviews*, 14(9), 3068-3075.
- [4] Vicente, E. D., & Alves, C. A. (2018). An overview of particulate emissions from residential biomass combustion. *Atmospheric Research*, 199, 159-185.
- [5] Fiedler, F. (2004). The state of the art of small-scale pellet-based heating systems and relevant regulations in Sweden, Austria and Germany. *Renewable and sustainable energy reviews*, 8(3), 201-221.
- [6] Boman, C., Pettersson, E., Westerholm, R., Boström, D., & Nordin, A. (2011). Stove performance and emission characteristics in residential wood log and pellet combustion, part 1: pellet stoves. *Energy & Fuels*, 25(1), 307-314.
- [7] Rabaçal, M., Fernandes, U., & Costa, M. (2013). Combustion and emission characteristics of a domestic boiler fired with pellets of pine, industrial wood wastes and peach stones. *Renewable Energy*, 51, 220-226.
- [8] De Soete, G. G. (1991, January). Heterogeneous N₂O and NO formation from bound nitrogen atoms during coal char combustion. In *Symposium (International) on Combustion* (Vol. 23, No. 1, pp. 1257-1264). Elsevier.
- [9] Qiu, G. (2013). Testing of flue gas emissions of a biomass pellet boiler and abatement of particle emissions. *Renewable energy*, 50, 94-102.
- [10] García-Maraver, A., Popov, V., & Zamorano, M. (2011). A review of European standards for pellet quality. *Renewable Energy*, 36(12), 3537-3540.
- [11] Johansson, L. S., Leckner, B., Gustavsson, L., Cooper, D., Tullin, C., & Potter, A. (2004). Emission characteristics of modern and old-type residential boilers fired with wood logs and wood pellets. *Atmospheric environment*, 38(25), 4183-4195.
- [12] Arranz, J. I., Miranda, M. T., Montero, I., Sepúlveda, F. J., & Rojas, C. V. (2015). Characterization and combustion behaviour of commercial and experimental wood pellets in South West Europe. *Fuel*, 142, 199-207.
- [13] Lehtimäki, M. (1983). Modified Electrical Aerosol Detector, Aerosol in the Mining and Industrial Work Environments. *Ann Arbor Science Publishers, Ann Arbor*.
- [14] C N Hamelinck, R A A Suurs, A P C Faaij. International bioenergy transport costs and energy balance. *Biomass and Bioenergy* 2005;29:114-34.

[15] OBAIDULLAH, M., et al. A review on particle emissions from small scale biomass combustion. *International Journal of Renewable Energy Research (IJRER)*, 2012, vol. 2, no 1, p. 147-159.

[16] Patashnick, H., & Rupprecht, E. G. (1991). Continuous PM-10 measurements using the tapered element oscillating microbalance. *Journal of the Air & Waste Management Association*, 41(8), 1079-1083.