



HAL
open science

Bio-energy Carriers as Back-up Fuel in Hybrid Solar Power Plants

Jan Baeyens, Shuo Li, Huili Zhang, Raf Dewil, Gilles Flamant, Renaud Ansart, Yimin Deng

► **To cite this version:**

Jan Baeyens, Shuo Li, Huili Zhang, Raf Dewil, Gilles Flamant, et al.. Bio-energy Carriers as Back-up Fuel in Hybrid Solar Power Plants. 10th International Conference on Environment Science and Engineering (ICESE 2020), May 2020, Vienne, Austria. pp.012012, 10.1088/1755-1315/544/1/012012 . hal-03116724

HAL Id: hal-03116724

<https://hal.science/hal-03116724>

Submitted on 20 Jan 2021

HAL is a multi-disciplinary open access archive for the deposit and dissemination of scientific research documents, whether they are published or not. The documents may come from teaching and research institutions in France or abroad, or from public or private research centers.

L'archive ouverte pluridisciplinaire **HAL**, est destinée au dépôt et à la diffusion de documents scientifiques de niveau recherche, publiés ou non, émanant des établissements d'enseignement et de recherche français ou étrangers, des laboratoires publics ou privés.



Open Archive Toulouse Archive Ouverte (OATAO)

OATAO is an open access repository that collects the work of Toulouse researchers and makes it freely available over the web where possible

This is a Publisher's version published in: <http://oatao.univ-toulouse.fr/27261>

Official URL: <https://doi.org/10.1088/1755-1315/544/1/012012>

To cite this version:

Baeyens, Jan and Li, Shuo and Zhang, Huili and Dewil, Raf and Flamant, Gilles and Ansart, Renaud  and Deng, Yimin *Bio-energy Carriers as Back-up Fuel in Hybrid Solar Power Plants*. (2020) In: 10th International Conference on Environment Science and Engineering (ICESE 2020), 18 May 2020 - 21 May 2020 (Vienne, Austria).

Any correspondence concerning this service should be sent to the repository administrator: tech-oatao@listes-diff.inp-toulouse.fr

Bio-energy Carriers as Back-up Fuel in Hybrid Solar Power Plants

Jan Baeyens¹, Shuo Li², Huili Zhang², Raf Dewil³, Gilles Flamant⁴, Renaud Ansart⁵ and Yimin Deng^{3,*}

1 European Powder and Process Technology, Tremelo, Belgium

2 Beijing University of Chemical Technology (BUCT), School of Life Science and Technology, Beijing, China

3 KULeuven, Department of Chemical Engineering, Process & Environmental Technology Lab., Sint-Katelijne-Waver, Belgium

4 PROMES-CNRS, Odeillo-Font Romeu, France

5 Laboratoire de Génie Chimique, Université de Toulouse, CNRS, INPT, UPS, Toulouse, France.

*E-mail: dengyimin0718@163.com

Abstract. Electricity from concentrated solar power (CSP) plants, gains an increasing interest and importance. To fully match the supply-demand principle, CSP processes include a thermal energy storage and back-up fuel supply. Novel CSP concepts are needed with specific targets of increased efficiency and reliability, and of reduced CAPEX and OPEX. The use of particle suspensions offers significant advantages since applicable in all sub-sections of the complete CSP as heat carrier from the receiver, to the heat storage, and ultimately to the power block. The use of particles in the steam generation (power block) is a common fluidized bed boiler technology. This paper will present the entire particle-based concept, while also discussing the potential to use biomass-based energy carriers as back-up heat supply. Process data and expected effects on the process economy of the system will be discussed.

1. Introduction

In the current CSP technology, mostly Parabolic Trough Collectors (PTC) and Solar Power Towers (SPT) [1] are used, with either thermal fluids or molten salt eutectics as respective heat carriers or transfer fluids (HTF).

Operating temperatures are limited to ~390 °C (PTC) or ~565 °C (molten salt in solar power towers, SPT). SPTs mostly apply molten salts, although direct steam or hot air applications are also proposed, each technology with its advantages and drawbacks [2–5], such as difficulties in storing heat in hot air and steam systems, possible solidification of molten salts at around 220 °C, molten salt degradation when heated beyond 565 °C, heat tracing of the molten salt circuits, etc.

Particle suspension do not suffer from these limitations, and can operate at a very high and low temperature, while also facilitating hot and cold storage [2]. The upper temperature limit will be determined by the high temperature mechanical properties of the construction materials. Worldwide, the 2030 CSP potential is forecast at over 260 GW of electricity, with about 30 to 40% from SPT technology [6].



Developments of new molten salts are considered, either by using mixes of the common Na/K nitrate eutectic with LiNO_3 or by using other eutectic mixes (CO_3^{2-} , Cl^- or F^- salts), although such salts can corrode construction materials at high temperatures [7–10]. Using particle suspensions as heat carrier has been examined at laboratory and pilot scale since about 2010 [11, 12]. The higher operating temperatures will foster the use of advanced power cycle configurations, with combined cycles (air or CO_2 Brayton plus steam Rankine) or even supercritical cycles. The cycle efficiencies are thereby expected to increase from 35% for steam conditions at 375 °C, to 40% for high-tech molten salt SPTs with steam conditions of 535 °C, and even to 45 and ~50% for supercritical and combined power generation concepts [13-16].

2. The application of particle suspensions as heat carriers

This concept relies upon using a bubbling fluidized bed of fine Geldart A type powders [17, 18], with a forced external particle circulation. In using A-type particles, the operating superficial air velocity can be low (max. 0.15 m/s), thus limiting the air-related sensible heat losses. The system is now commonly referred to as Particle-in-Tube or as the Upflow Bubbling Fluidized Bed (UBFB). Imposed particle circulation rates, expressed per unit cross sectional area of the receiver tubes, can reach 150 $\text{kg/m}^2\text{s}$. During the project development, the receiver internal diameter was gradually increased from 29 to 50 mm. Zhang et al. [11] reviewed previous research on similar dense up-flow systems.

The UBFB novel concept was developed through French National and European funding [19-23]. The layout of the UBFB loop involves a pressurized bottom fluidized bed (also called dispenser) and operated at a superficial air velocity close to the particle minimum fluidization velocity, a number of vertical receiver tubes that are exposed over a given height to the concentrated solar irradiation and fitted with a secondary air injection, a disengagement chamber at the receiver tube discharges, a pressurized storage hopper with downcomer and non-mechanical recycle valve (L-valve) to the dispenser [11, 24].

The heat transfer from the receiver wall to the UBFB is high, and the result of the vigorous bubbling and associated particle renewal at the wall [25] (since bubbles in A-type powders are known to reach a maximum stable bubble size and a high bubble frequency). These bubbles also induce a "gulfstream" mixing throughout the bed (and hence tube) height [26].

The integration of the particle suspension HTF, in either bubbling or moving bed [27] mode, throughout the whole power plant system, is illustrated in Figures 1 and 2 below, for different power generation concepts. The A-type particles are readily flowable, hence fostering the use of a tube bank filled with phase change materials (E-PCM) to supplement the sensible heat storage of the powders, with a latent heat storage contribution [28–30].

3. On-sun proof of concept

Single and multi-tube particle-driven receivers were assessed at the CNRS solar furnace of Font Romeu (France), with various fine A-type powders as suspension material (silicon carbide, cristobalite and olivine).

Superficial air velocities at operating bed temperature of maximum 700 °C varied from 5 to about 20 times the minimum fluidization velocity of the powders (0.5 to 0.8 cm/s). Solid circulation fluxes up to about 50 $\text{kg/m}^2\text{s}$ were imposed. The experimental set-ups and experimental procedures were previously described in detail [11, 12, 30, 31].

The heat transfer coefficient (HTC) between the wall and the UBFB were determined per total m^2 of the receiver tube surface area. They were found to be a nearly linear function of the imposed solid circulation flux, with a limited impact of the superficial gas velocity only. Values of ~50 kW/m^2 were measured at a solid circulation flux of about 10 $\text{kg/m}^2\text{s}$, increasing steadily to ~150 kW/m^2 at 46 $\text{kg/m}^2\text{s}$, and this in both the single and multi-tube testing.

With the contributions of both the particle convection and radiation heat transfer at the high wall temperatures, the overall heat transfer coefficient ranged from 430 $\text{W/m}^2\text{K}$ to 1120 $\text{W/m}^2\text{K}$ [8, 26].

4. Biomass-based Back-up Fuel Systems

Biomass is widely available, with an energy content of 15 to 23 MJ/kg. Biomass or its pyrolysis/gasification derivatives can be readily applied in a hybrid CSP. A currently investigated hybrid co-generation plant is illustrated in Figure 1, where the possible application of biomass or its derived syngas as back-up fuel is indicated, and applied in various sub-sections of the overall plant layout.

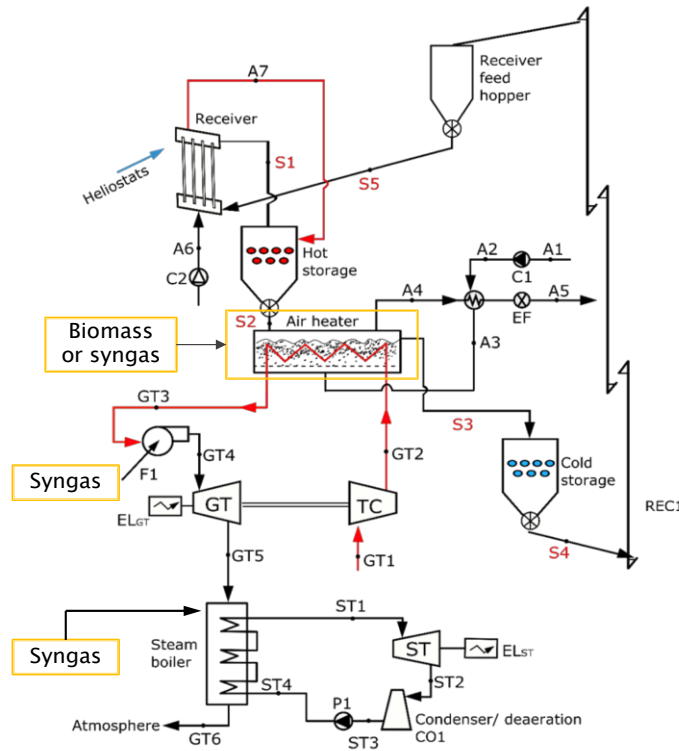
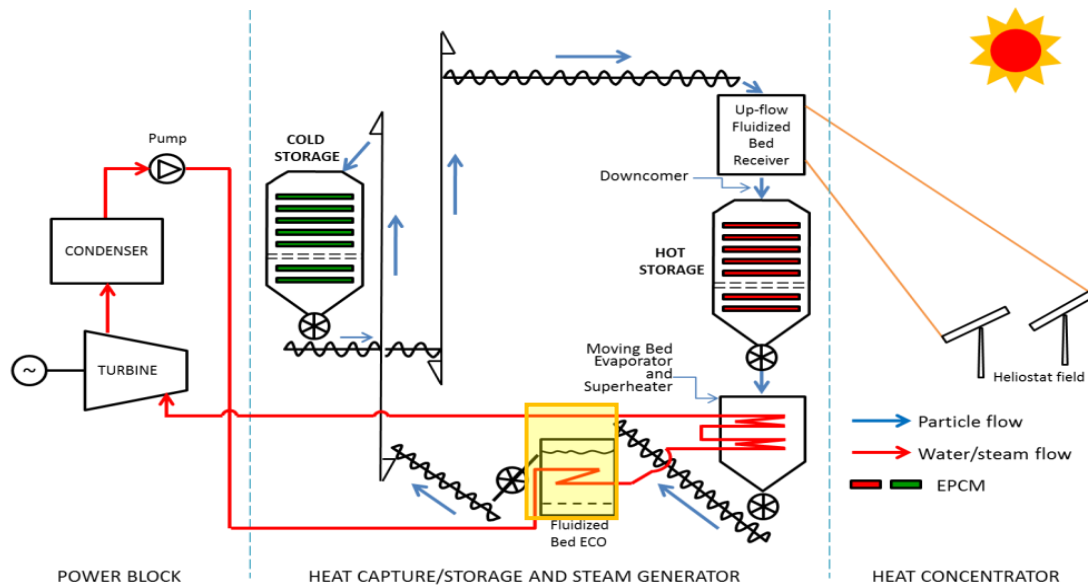

Figure 1. The CNRS hybrid co-generation project at the Themis CSP.

Several alternative applications were assessed and are represented in Figure 2.

(a)



(a)

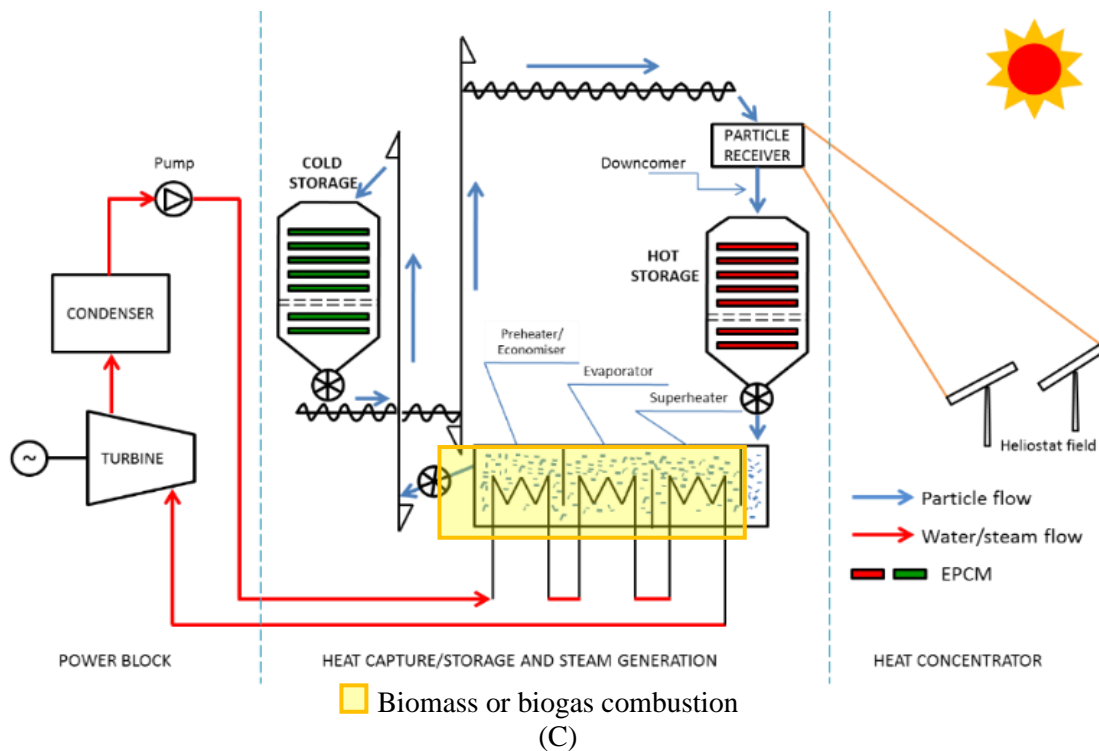
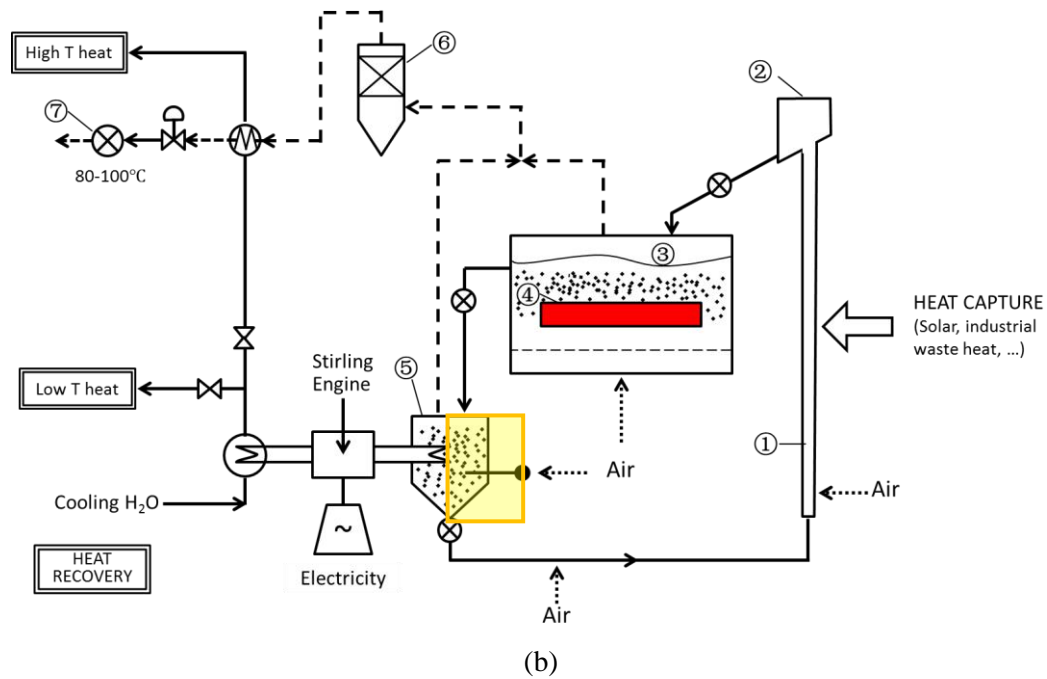

Figure 2. Different options of a hybrid biomass - CSP power plant.

5. Conclusion and recommendations

The UBFB receiver, operated with particles at high temperatures, and the subsequent application of the particle suspension in the different sub-sections of the power plant, fosters the use of high efficiency power generation cycles. It is expected that the particle loops, operating at higher temperatures throughout the process, will significantly decrease the required heat storage volumes for an equivalent capacity of the molten salt applications. Since solidification is no longer an issue of

concern, circuits will not require a heat tracing. The higher cycle efficiencies achieved, will moreover allow a reduced size of the heliostat field. These SPT advantages should reduce the levelized cost of electricity (LCOE) by between 10 to 20%, with a target electricity cost of less than 100€/MWh. Since a back-up system is required for non-sun periods, the use of biomass-based energy carriers has a high potential to further reduce the back-up fuel environmental footprint.

6. References

- [1] Zhang H L, Baeyens J, Degrève J and Cacères G. 2013 Concentrated solar power plants: Review and design methodology. *Renew Sustain Energy Rev* **22** 466–81
- [2] Zhang H L, Baeyens J, Cáceres G, Degrève J and Lv YQ. 2016 Thermal Energy Storage: Recent Developments and Practical Aspects. *Prog Energy Combust Sci* **53** 1-40
- [3] Steinmann W-D and Eck M. 2006 Buffer storage for direct steam generation. *Sol Energy* **80** 1277–82
- [4] U.S. Department of Energy. 2012 *Improving steam system performance, a sourcebook for industry*. DOE/GO-102012-3423. 2nd ed
- [5] Bradshaw RW and Siegel NP. 2009 Molten Nitrate Salt Development For Thermal Energy Storage In Parabolic Trough Solar Power Systems. *Es2008 Proc 2nd Int Conf Energy Sustain* **2** 631–7.
- [6] Zhang HL. 2016 The development of power circulation systems in solar energy capture and storage (KU Leuven)
- [7] Zhang HL, Gowing T, Degrève J, Leadbeater T and Baeyens J. 2016 The use of particle heat carriers in the Stirling engine concept. *Energy Technol.* **4(3)** 401-408
- [8] Reddy, R. G. 2013 The University of Alabama. Novel Molten Salts Thermal Energy Storage for Concentrating Solar Power Generation. doi:10.2172/1111584
- [9] Cabeza LF, Gutierrez A, Barreneche C, Ushak S, Fernández ÁG, Inés Fernández A and Mario G. 2015 Lithium in thermal energy storage: A state-of-the-art review. *Renew Sustain Energy Rev* **42** 1106–12
- [10] Fernández AG, Ushak S, Galleguillos H and Pérez FJ. 2014 Development of new molten salts with LiNO₃ and Ca(NO₃)₂ for energy storage in CSP plants. *Appl Energy* **119** 131–40
- [11] Zhang H L, Benoit H, Gauthier D, Degrève J, Baeyens J, López IP, Lopez I P, Hemati M and Flamant G. 2016 Particle circulation loops in solar energy capture and storage: Gas--solid flow and heat transfer considerations. *Appl Energy* **161** 206–24
- [12] Flamant G, Gauthier D, Benoit H, Sans J-L, Garcia R, Boissière B, Ansart R and Hemati M. 2013 Dense suspension of solid particles as a new heat transfer fluid for concentrated solar thermal plants: On-sun proof of concept. *Chem Eng Sci* **102** 567–76
- [13] Cziśla F, Kremer H, Much U, Riemschneider J-E and Quinkertz R. 2009 Advanced 800+ MW Steam Power Plants and Future CCS Options. *Siemens Ind Turbomach* 1–21
- [14] Siemens. 2010 *Steam turbines for CSP plants*. (Erlangen, Germany)
- [15] Singer C, Buck R, Pitz-Paal R and Müller-Steinhagen H. 2010 Assessment of Solar Power Tower Driven Ultrasupercritical Steam Cycles Applying Tubular Central Receivers With Varied Heat Transfer Media. *J Sol Energy Eng* **132** 041010
- [16] Torresol Energy. www.torresolenergy.com, retrieved in April 2020
- [17] Baeyens J and Geldart D. 1886 *Gas Fluid. Technol.*, (Chichester, UK: John Wiley & Sons Ltd) ed Geldart D chapter 5
- [18] Baeyens J and Geldart D. 1986 Solids Mixing. *Gas Fluid. Technol.*, (UK: John Wiley & Sons Ltd.) ed Geldart D p 97–122
- [19] Matsubara K, Kazuma Y, Sakurai A, Suzuki S, Soon-Jae L, Kodama T, et al. 2014 High-temperature Fluidized Receiver for Concentrated Solar Radiation by a Beam-down Reflector System. *Energy Procedia* **49** 447–56
- [20] Martin J and Vitko J. 1982 ASCUAS: a solar central receiver utilizing a solid thermal carrier. doi:10.2172/5663779

- [21] Siegel N, Gross M, Ho C, Phan T and Yuan J. 2014 Physical Properties of Solid Particle Thermal Energy Storage Media for Concentrating Solar Power Applications *Energy Procedia* **49** 1015–23
- [22] Zhang HL, Baeyens J, Degrève J, Brems A and Dewil R. 2014 The convection heat transfer coefficient in a Circulating Fluidized Bed (CFB). *Adv Powder Technol* **25** 710–5
- [23] Next-CSP project, H2020 funding (grant H2020-LCE-07-2016 NextCSP Project N° 727762).
- [24] Baeyens J and Geldart D. 1980 Modelling approach to the effect of equipment scale on fluidised bed heat transfer data. *J Powder Bulk Solids Technol* **4** 1
- [25] Geldart D. 1986 *Gas Fluidization Technology* (London Wiley)
- [26] Zhang H, Degrève J, Dewil R and Baeyens J. 2015 Wall-to-Suspension Heat Transfer in a CFB Downcomer. *J Powder Technol* 1–9
- [27] Fernandes D, Pitié F, Cáceres G and Baeyens J. 2012 Thermal energy storage: “How previous findings determine current research priorities.” *Energy* **39** 246–57.
- [28] Pitié F, Zhao CY, Baeyens J, Degrève J and Zhang HL. 2013 Circulating fluidized bed heat recovery/storage and its potential to use coated phase-change-material (PCM) particles. *Appl Energy* **109** 505–13
- [29] Zhang HL, Baeyens J, Degrève J, Cáceres G, Segal R and Pitié F. 2014 Latent heat storage with tubular-encapsulated phase change materials (PCMs). *Energy* **76** 66–72
- [30] Benoit H, Perez I, Gauthier D, Sans J-L and Flamant G. 2015 On-sun demonstration of a 750°C heat transfer fluid for concentrating solar systems: dense particle suspension in tube. *Sol Energy* **118** 622–33
- [31] B. Boissiere, R. Ansart, D. Gauthier, G. Flamant and M. Hemati 2015 Experimental hydrodynamic study of gas-particle dense suspension upward flow for application as new heat transfer and storage fluid *Can. J. Chem. Eng.* **93** 317–330

Acknowledgments

The authors acknowledge the European H2020 funding (grant H2020-LCE-07-2016 NextCSP Project N° 727762).