



HAL
open science

InSAR Corner Cube at GRSM.

M. Aimar, Clément Courde, Xavier Collilieux, Bénédicte Fruneau, Guillaume Schmidt, Isabelle Delprat, Damien Pesce, Fabien Bergerault, Pierre Cumerlato, Guy Woppelmann

► **To cite this version:**

M. Aimar, Clément Courde, Xavier Collilieux, Bénédicte Fruneau, Guillaume Schmidt, et al.. InSAR Corner Cube at GRSM.. 2019 ILRS Technical Workshop: Laser ranging: To improve economy, performance, and adoption for new applications., ILRS, Oct 2019, Stuttgart, Germany. hal-03114069

HAL Id: hal-03114069

<https://hal.science/hal-03114069>

Submitted on 18 Jan 2021

HAL is a multi-disciplinary open access archive for the deposit and dissemination of scientific research documents, whether they are published or not. The documents may come from teaching and research institutions in France or abroad, or from public or private research centers.

L'archive ouverte pluridisciplinaire **HAL**, est destinée au dépôt et à la diffusion de documents scientifiques de niveau recherche, publiés ou non, émanant des établissements d'enseignement et de recherche français ou étrangers, des laboratoires publics ou privés.



ILRS TECHNICAL WORKSHOP 2019 (Stuttgart 21st – 25th October)

Session 2 : Improving current station performance (Local ties).

Title : InSAR Corner Cube at GRSM.

Mourad Aimar ¹, Clément Courde ¹, Xavier Collilieux ^{2,3}, Bénédicte Fruneau ⁴, Guillaume Schmidt ³,
Isabelle Delprat ³, Damien Pesce ⁵, Fabien Bergerault ⁵, Pierre Cumerlato ⁵, Guy Wöppelmann ⁶.

¹ UCA, CNRS, OCA, IRD, 06460 Caussols, France.

² Université de Paris, IPGP, CNRS, IGN, F-75005 Paris, France.

³ ENSG-Géomatique, IGN, F-77455 Marne-la-Vallée, France.

⁴ LaSTIG, Université Paris-Est, UPEM, IGN, Marne-la-Vallée, France.

⁵ INIGF, Saint-Mandé, France.

⁶ Laboratoire L.E.S., UMR7266 – Univ La Rochelle and CNRS, La Rochelle, France.

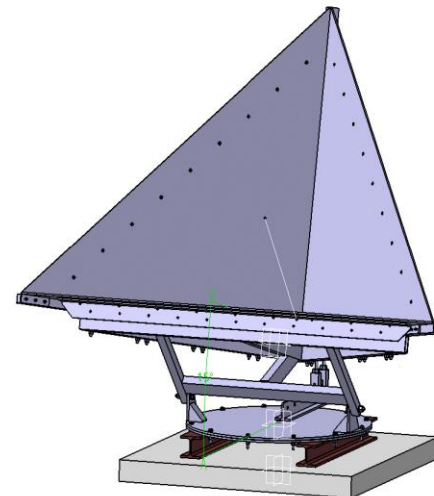
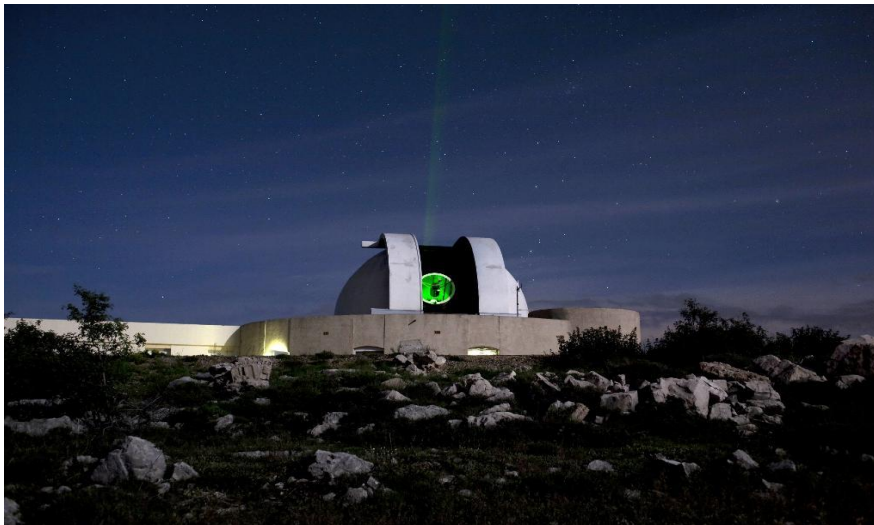

1 – Context : Geodetic observatories.

A geodetic observatory consists of four technics :

VLBI
(Very Long
Baseline
Interferometry)

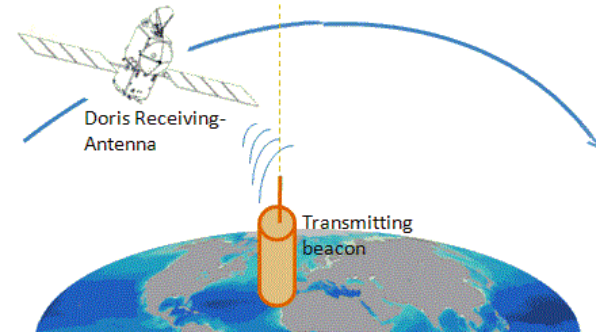

DORIS
(Doppler Orbitography by Radiopositioning
Integrated on Satellite)

GNSS
(Global Navigation
Satellite Service)



SLR / LLR
(Satellite/Lunar
Laser Ranging)

1 – Context : Geodetic observatories.



	Product	VLBI	SLR	GNSS	DORIS
Earth rotation	length of day	XXX	X	XXX	
	movement of pole	XXX	XX	XXX	X
	nutation	XXX		X	
	UT1	XXX			

Terrestrial frame	coverage homogeneity	X	X	XX	XXX
	center of mass		XXX	X	X
	center of figure	XX			
	tectonic movements	XXX	XX	XXX	XXX
	densification		X	XXX	XX

Celestial frame		XXX			
------------------------	--	-----	--	--	--

Gravity field	high wavelengths (statistical)		XXX	XX	X
	short wavelengths (statistical)		XX	XXX	XX
	temporal variations		XX	X	

2 – Calern's multitechnical geodetic observatory :

Co-location site which host three different spatial geodesy technics :

- SLR/LLR station (MéO) ;
- 2 GNSS receivers : GRAC and GRAS ;
- DORIS beacon : permanent station since september 2018 ;

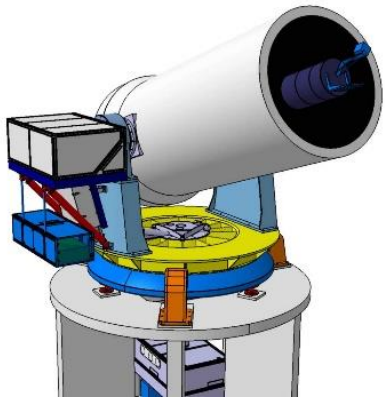

MéO



GRAC



GRAS

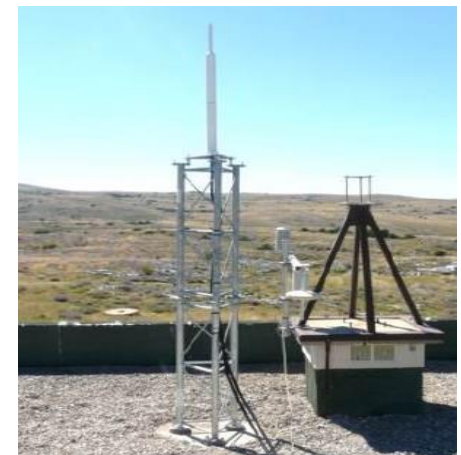

DORIS Beacon

2 – Calern's multitechnical geodetic observatory :

- Located in south of France, the site was inaugurated in 1974 ;
- Calcerous plate of 20 km² in the Grasse hinterland :
 - Altitude : 1270m (longitude 6,9230°E ; latitude 43,750° N) ;
 - Good compromise between accessibility (20 km of Grasse) and astronomical quality ;



3 – Improving current station performance :

Various arguments led us to install an InSAR Corner Cube :

→ Local ties : 1x/year, IGN (France) carry out the local ties in our co-location site. But, if there are deformation of soils ? An InSAR CC allows to monitor the local stability and ground displacement ;

→ Seasonal hydraulic load : InSAR method demonstrate its very good hability to measure vertical effects (8-9 mm North and Est component) ^[1]. With an InSAR CC, we can reach a better accuracy ;

→ Tide gauges : an InSAR CC can improve the measure for a tide gauge near from the coast and who can't be equipped with a GNSS receiver ^[2] ;

→ Global Geodetic Observing System (GGOS) : millimetric accuracy, and stability better than 0,1mm/year ;

[1] : Multi-geodetic characterization of the seasonal signal at the CERGA geodetic reference station, France (A. Memin and al, EGU, 2017) ;

[2] : Calibrating the SAR SSH of Sentinel-3A and CryoSat-2 over the Corsica Facilities (P. Bonnefond and al, Remote Sensing, 2018) ;



4 – Advantages of a Corner Cube (CC) :

- CC is a passive instrument (doesn't need any energy) ;
- ESA provides freely SAR images from Sentinel 1A & 1B (Copernicus program) ;
- SAR images acquired day and night, at all weather (C-band) ;
- Monitoring the local stability, and ground displacement in our co-location site ;
- Monitoring the seasonal hydraulic load in our site, with a better accuracy ;

A corner reflector represents an identifiable physical point scatter, exhibiting a strong signal in radar images with a stable phase through time, allowing a good precision of displacement measurement.



5 – Design of the Corner Cube :

- To measure displacement $< 0,5\text{mm}$ in C-band :
CR side length = $1,5\text{m}$ (hypotenuse side = $2,12\text{m}$) ^[3] ;
- To resist to the wind up to 150km/h : thickness = 8mm ;
- To maximize the signal backscattered :
 - Flatness default (plate) $< 0,75\text{mm}$;
 - Perpendicularity default (plates between them) $< 2\text{mm}$,
- Plate materiel : aluminium, powdercoated (grey color) ;
- Orientable in azimuth and elevation ;
- Fixed on a $1\text{m} \times 1\text{m}$ concrete slab (totally hidden by the CC to prevent additional reflection) ;

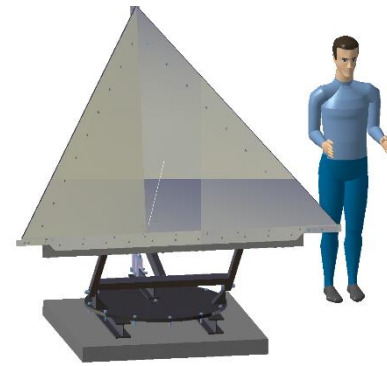

[3] : The Design of Radar Corner Reflectors for the Australian Geophysical Observing System. A single design suitable for InSAR deformation monitoring and SAR calibration at multiple microwave frequency bands (Garthwaite and al, Geoscience Australia record, 2015/03, 2015b) ;

5 – Design of the Corner Cube :

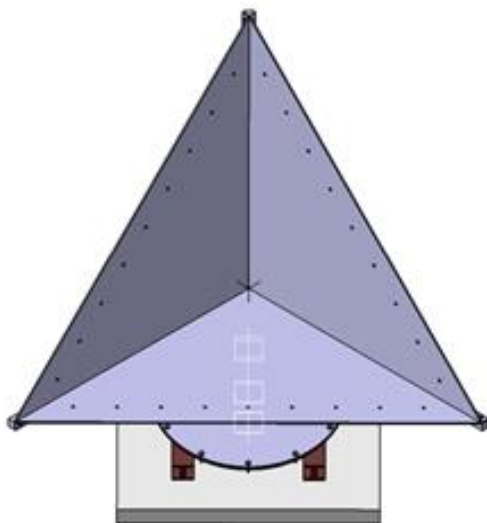
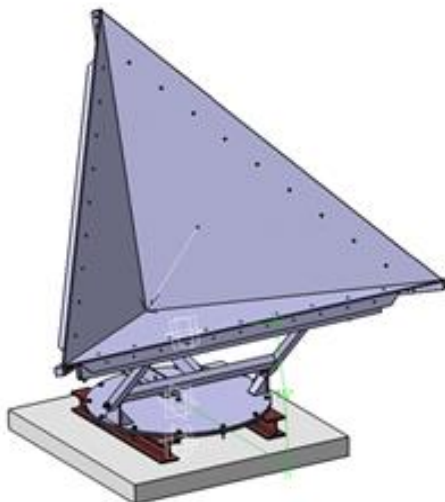
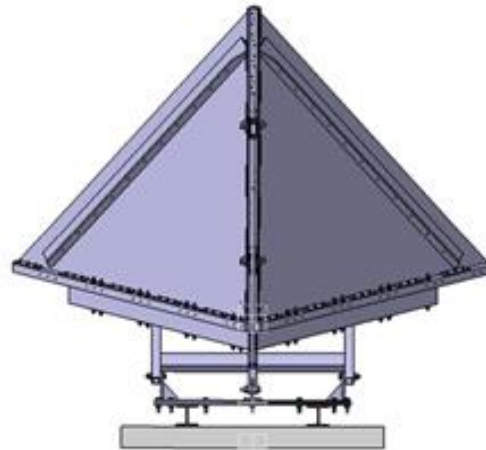
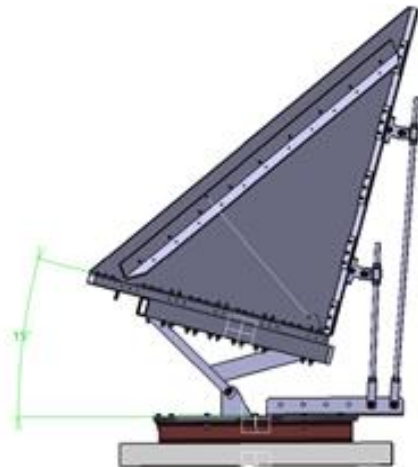
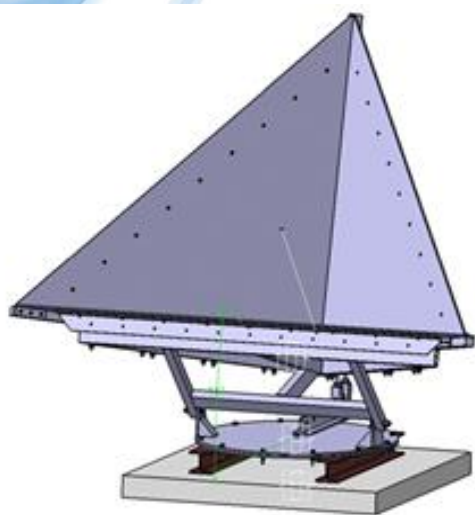

6 – Sentinel 1A et 1B :

- Calern site is visible by S1A and S1B from 4 distinct relative orbits :
- 2 ascending (88, 161) and 2 descending (66, 139) ;
 - With a time revisit of 6 days ;
 - Provides 5 images for S1A, and 4 images for S1B ;

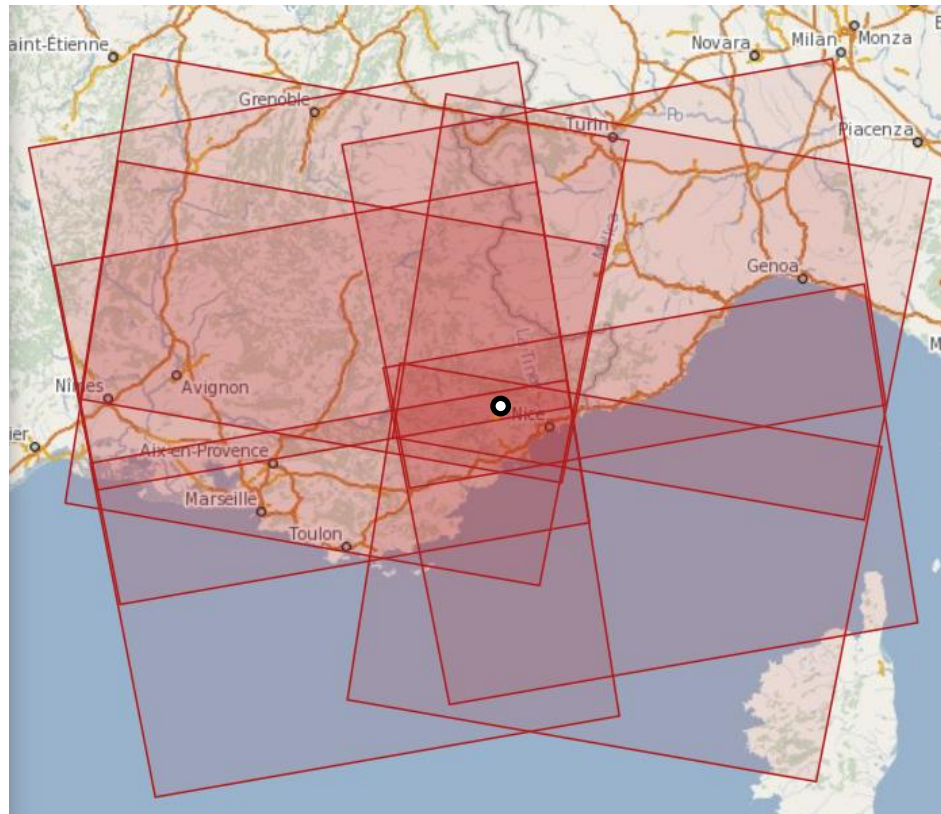

<https://scihub.copernicus.eu/dhus/#/home>



7 – Site selection and validation :

The choice of the site, different constraints must be followed ^[4] :

- Clear sky visibility toward East and West ;
- No additionnal multipath for GNSS stations, or DORIS station ;
- Low radar backscatter signal prior the installation ;

After a test phase (summer 2018) in differente locations, regarding the different Sentinel-1 orbits, we have choose the one which is close to the CATS stations :

- Located at 100m from the closest GNSS station ;
- 70m from the DORIS station ;

^[4] : Practical Considerations before Installing Ground-Based Geodetic Infrastructure for Integrated InSAR and cGNSS Monitoring of Vertical Land Motion (Parker and al, Sensors 2017) ;

7 – Site selection and validation :

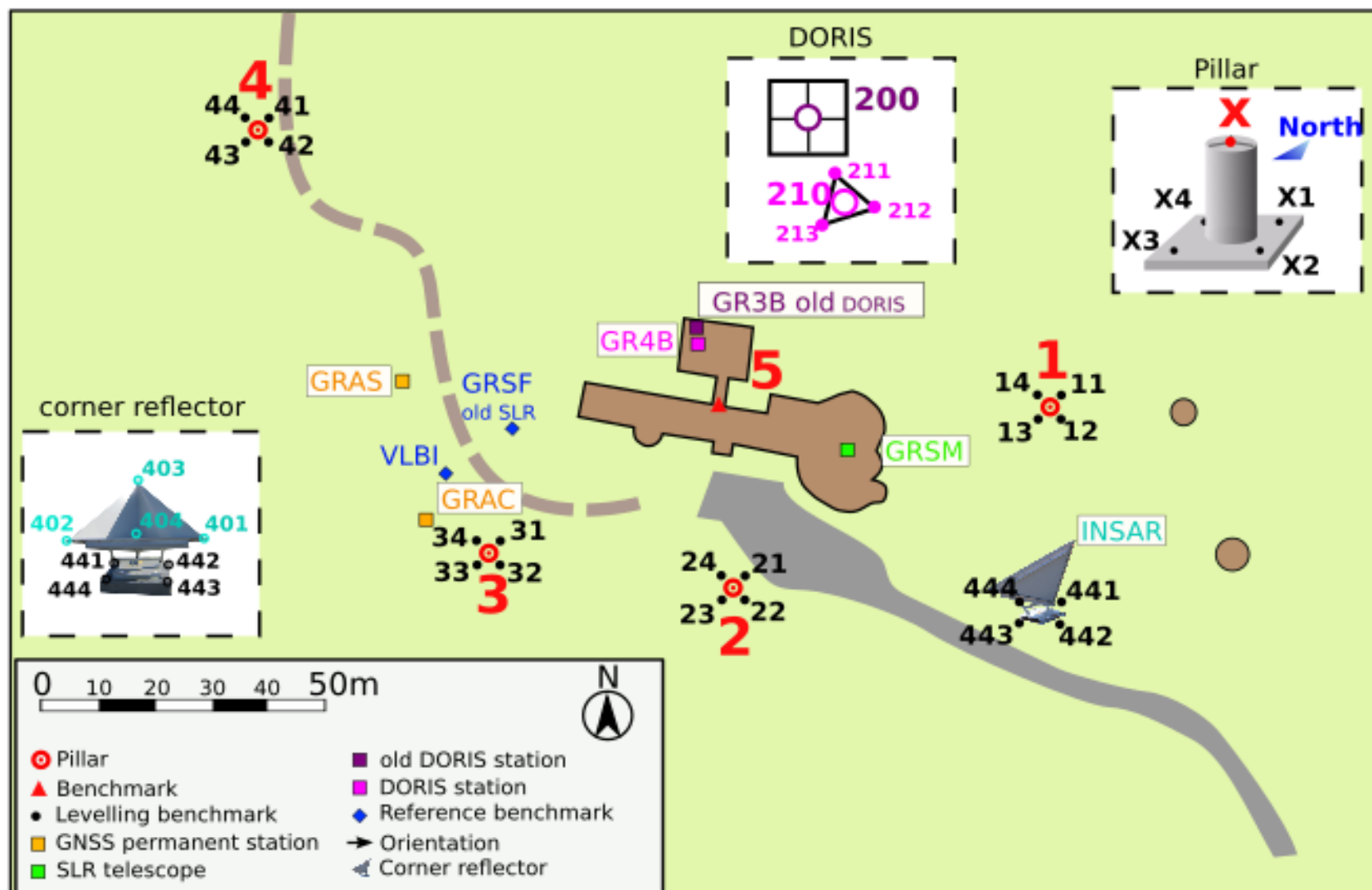

Map of Calern geodetic observatory and its geodetic benchmarks.



7 – Site selection and validation :

SCR before/after the installation of the CC.

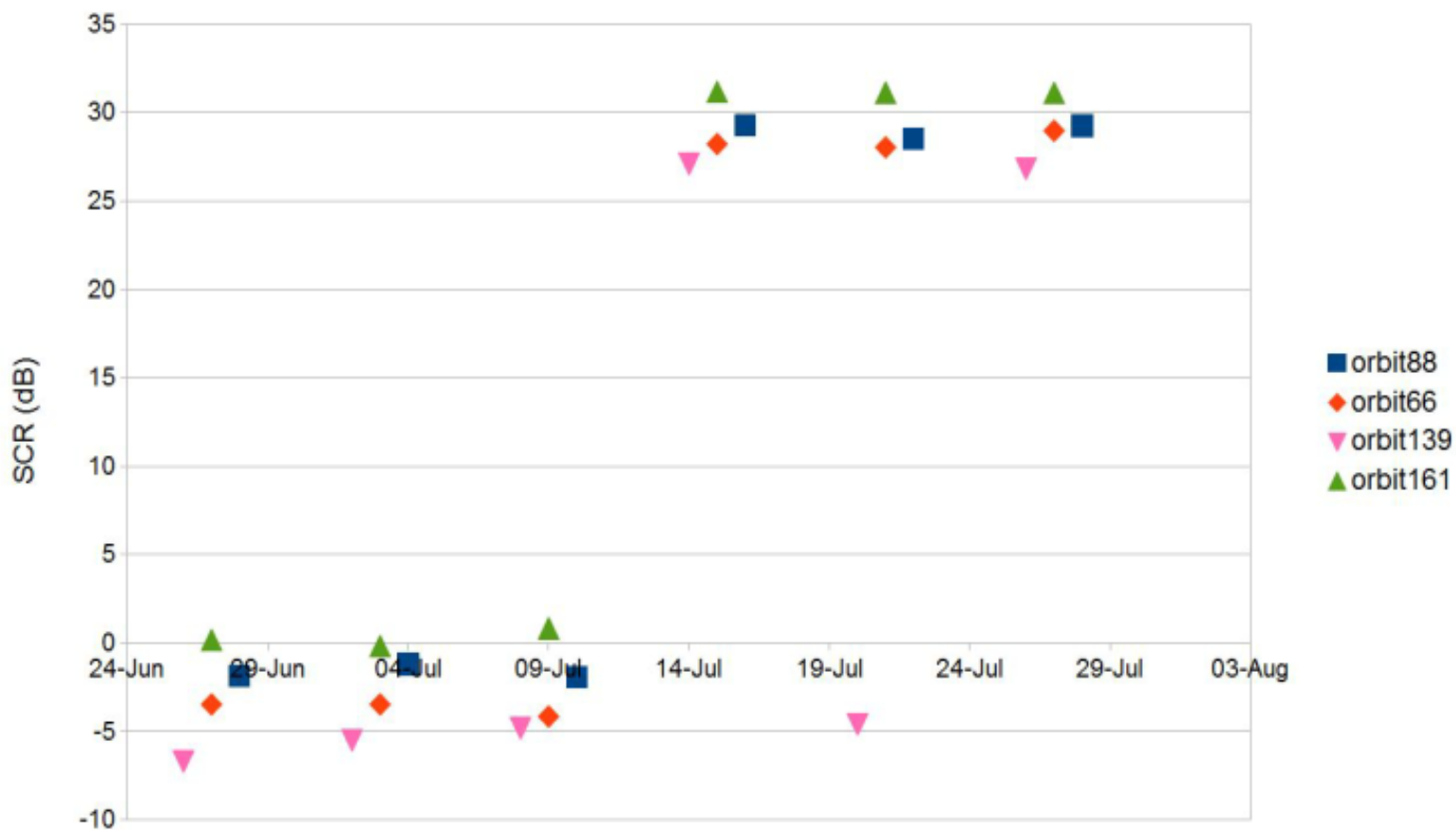



7 – Site selection and validation :

- These results validate our choice of location for the CC (close to the CATS stations) ;
- We decided to keep the CC toward the relative orbit 88. Its small incidence angle (35°) makes InSAR more sensitive to the vertical component of the deformation ;
- The CC was definitively anchored on its concrete slab, the 3rd December 2018 ;



8 – Impact on GNSS and DORIS stations :

→ There is no multipath impact on GNSS permanent stations (a), and the DORIS permanent station (a) ;

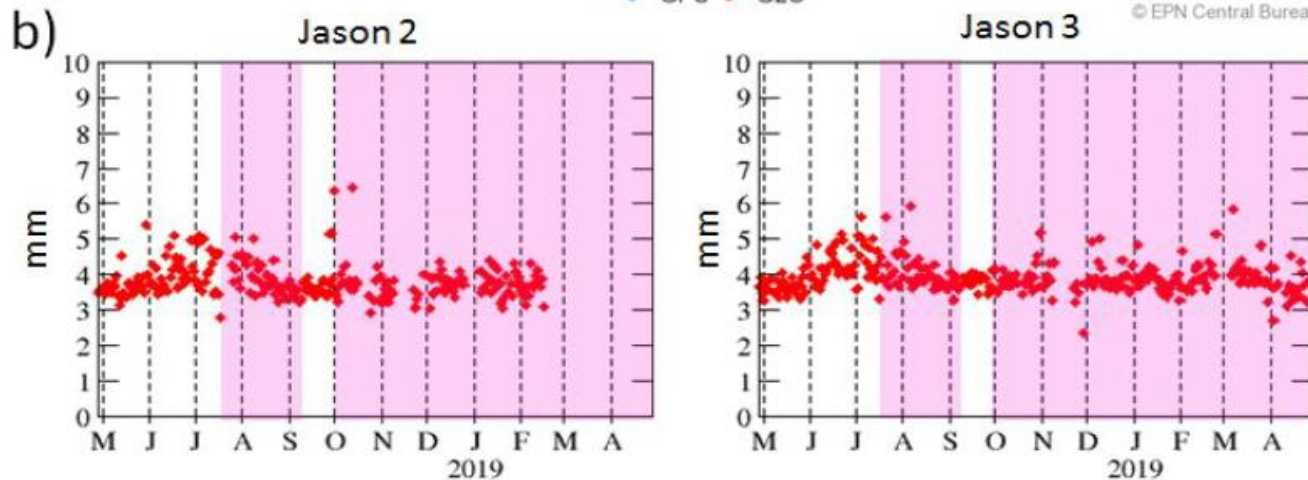
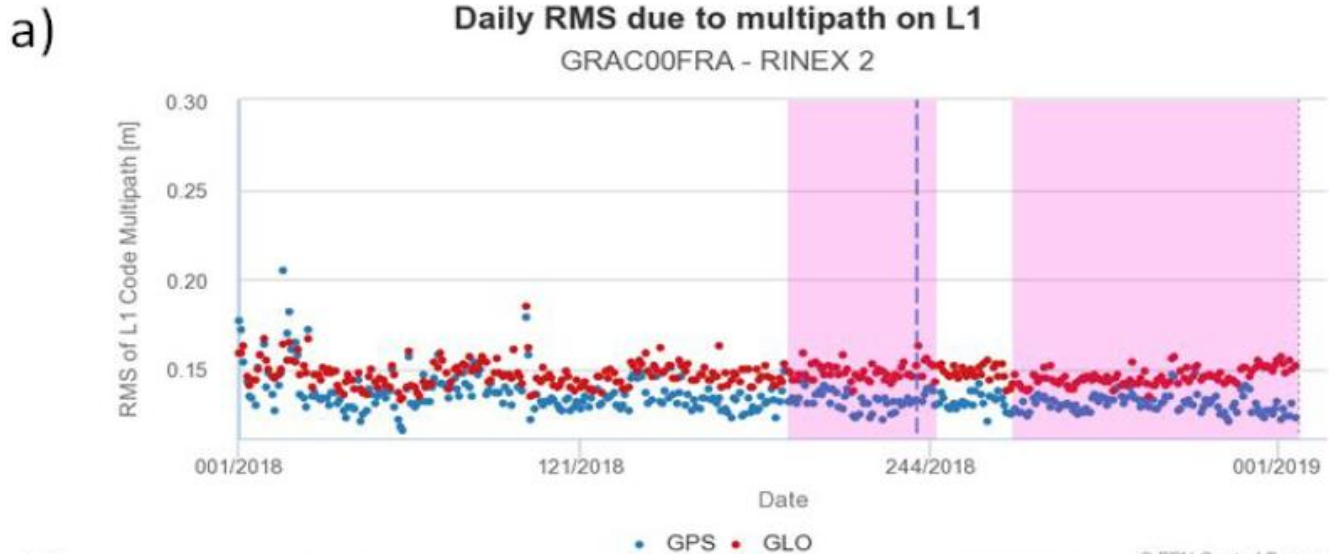



Conclusion :

- We have installed a permanent CC, new geodetic instrument, at the Calern Geodetic Observatory ;
- No multipath impact on GNSS and DORIS stations ;
- The SCR > 27dB → theoretical measurement precision of 0,1 mm ;
- It will be surveyed regularly to monitor its stability ;
- The CR designed to be versatil : it can be oriented toward differents satellites orbits ;

Acknowledgment :

- PN GRAM, BQR OCA, BQR GEOAZUR wich funded the CR ;
- S2M (OCA) for the design, the manufacture, and the implementation ;

Collilieux X., C. Courde, B. Fruneau, M. Aimar, G. Schmidt, I. Delprat, D. Pesce, F. Bergerault, P. Cumerlato and G. Wöppelmann (2019) Validation of a Corner Reflector installation at OCA multi-technique geodetic Observatory, Journal of Applied Geodesy, submitted.