



HAL
open science

Data-driven control in the frequency-domain: From reference model selection to controller validation

Pauline Kergus, Martine Olivi, Charles Poussot-Vassal, Fabrice Demourant

► To cite this version:

Pauline Kergus, Martine Olivi, Charles Poussot-Vassal, Fabrice Demourant. Data-driven control in the frequency-domain: From reference model selection to controller validation. European Network of System Identification, 2019, Maastricht, Netherlands. hal-03095969

HAL Id: hal-03095969

<https://hal.science/hal-03095969v1>

Submitted on 4 Jan 2021

HAL is a multi-disciplinary open access archive for the deposit and dissemination of scientific research documents, whether they are published or not. The documents may come from teaching and research institutions in France or abroad, or from public or private research centers.

L'archive ouverte pluridisciplinaire **HAL**, est destinée au dépôt et à la diffusion de documents scientifiques de niveau recherche, publiés ou non, émanant des établissements d'enseignement et de recherche français ou étrangers, des laboratoires publics ou privés.

Data-driven control in the frequency-domain: From reference model selection to controller validation

Pauline Kergus, Martine Olivi, Charles Poussot-Vassal, Fabrice Demourant

ONERA, Toulouse, France
INRIA, Sophia-Antipolis, France

Loewner Data-Driven Control: general formulation

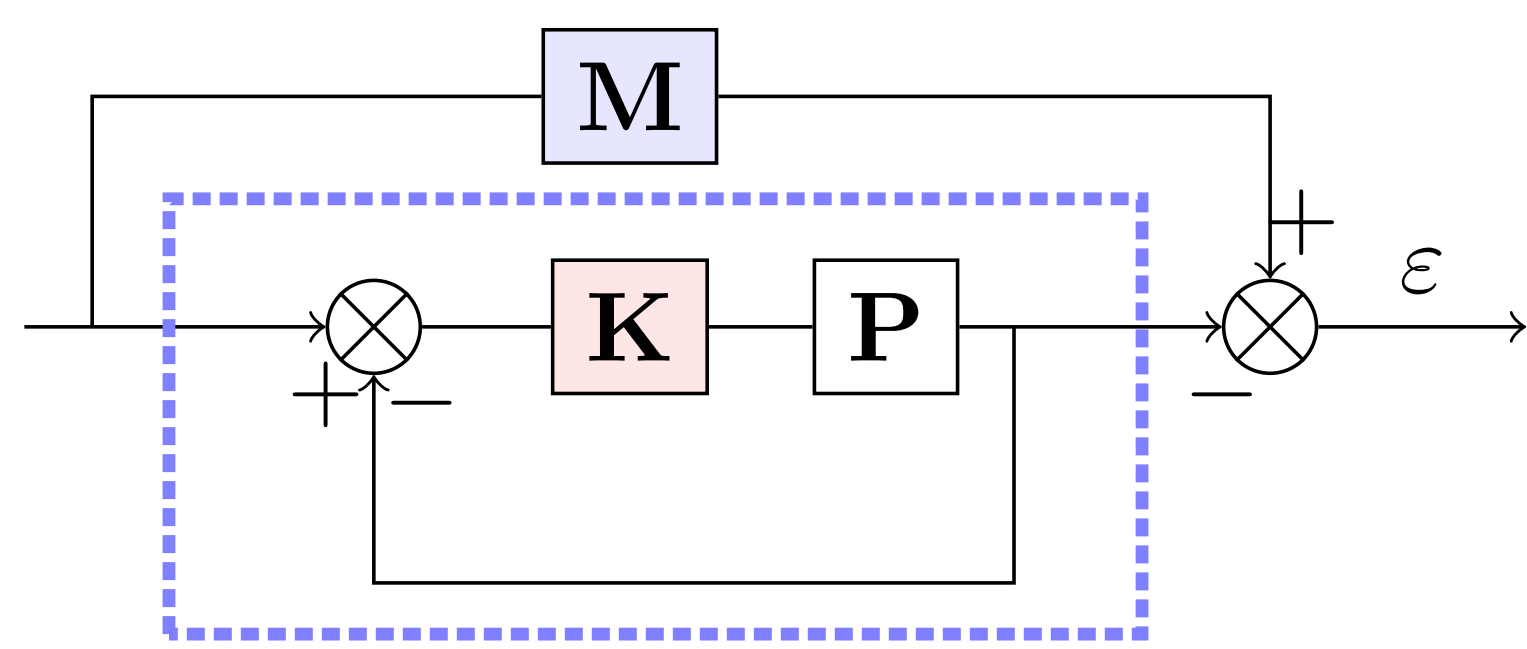

Input data

- Frequency-domain data from the plant P : $\{\omega_i, \Phi_i\}$, $i = 1 \dots N$.
- Reference model M .

Proposed methodology

1. Computation of the ideal controller K^* frequency-response: $K^*(j\omega_i) = \Phi_i^{-1}M(j\omega_i)(I - M(j\omega_i))^{-1}$.
2. Interpolation and reduction of the ideal controller K^* through the Loewner framework.

$$\left. \begin{aligned} P(s) &= \frac{0.03616(s-140.5)(s-40)^3}{(s^2+1.071s+157.9)(s^2+3.172s+1936)} \\ M(s) &= \frac{1}{0.04s^2+0.4s+1} \end{aligned} \right\}$$

$$K^*(s) = k \frac{(s^2+1.071s+157.9)(s^2+3.172s+1936)}{s(s+10)(s-140.5)(s-40)^3}$$

- The reference model should be achievable by the plant.
- A data-driven closed-loop stability analysis is needed.

Selection of an achievable reference model

$$\begin{cases} y_{z_i}^T P(z_i) = 0 \\ y_{p_j}^T P(p_j) = \infty \end{cases} \Rightarrow \begin{cases} y_{z_i}^T M(z_i) = 0 \\ M(p_j) y_{p_j} = y_{p_j} \end{cases}$$

- 1) Projection of the available data to determine the nature of P : the system is stable but Non-Minimum Phase (NMP).

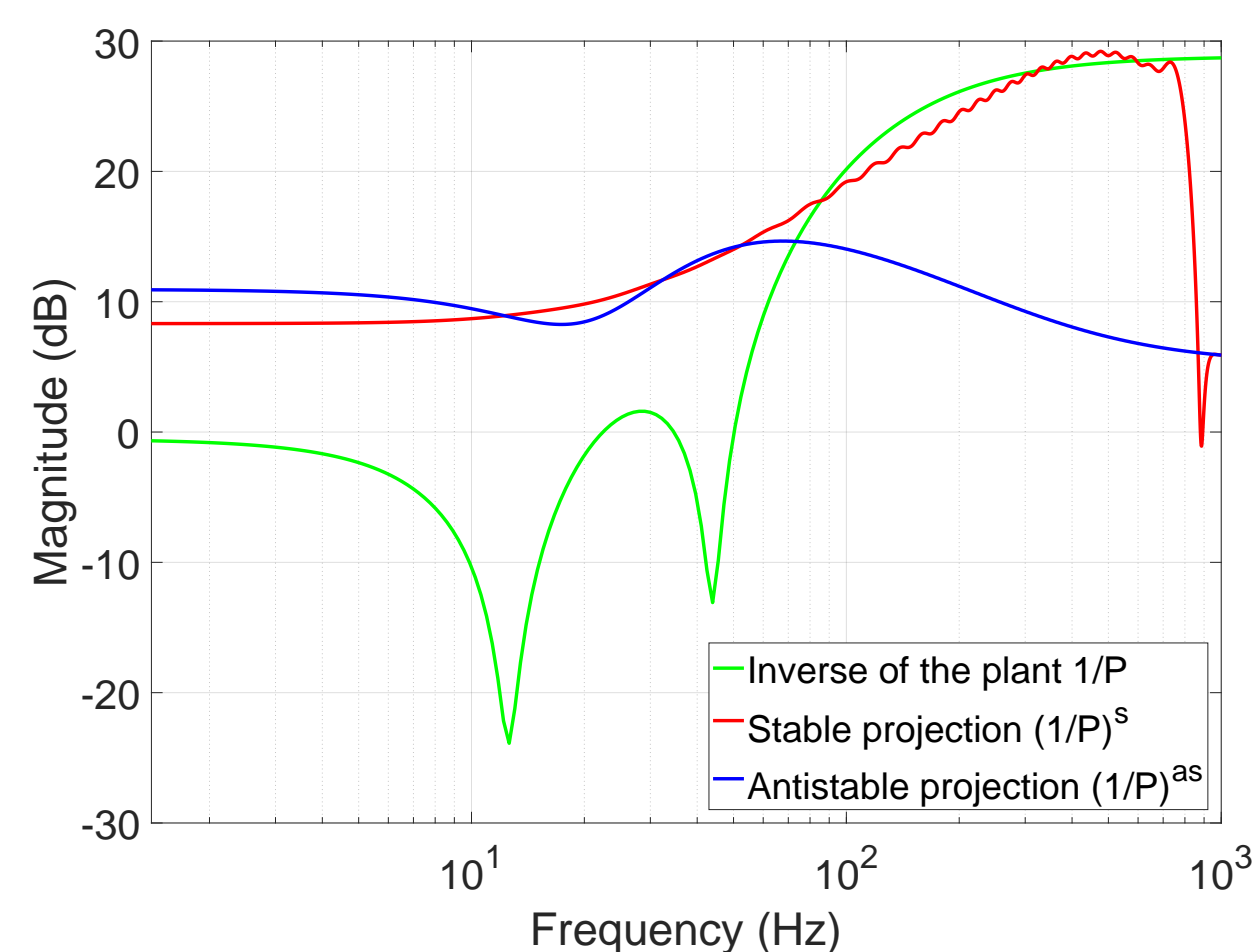
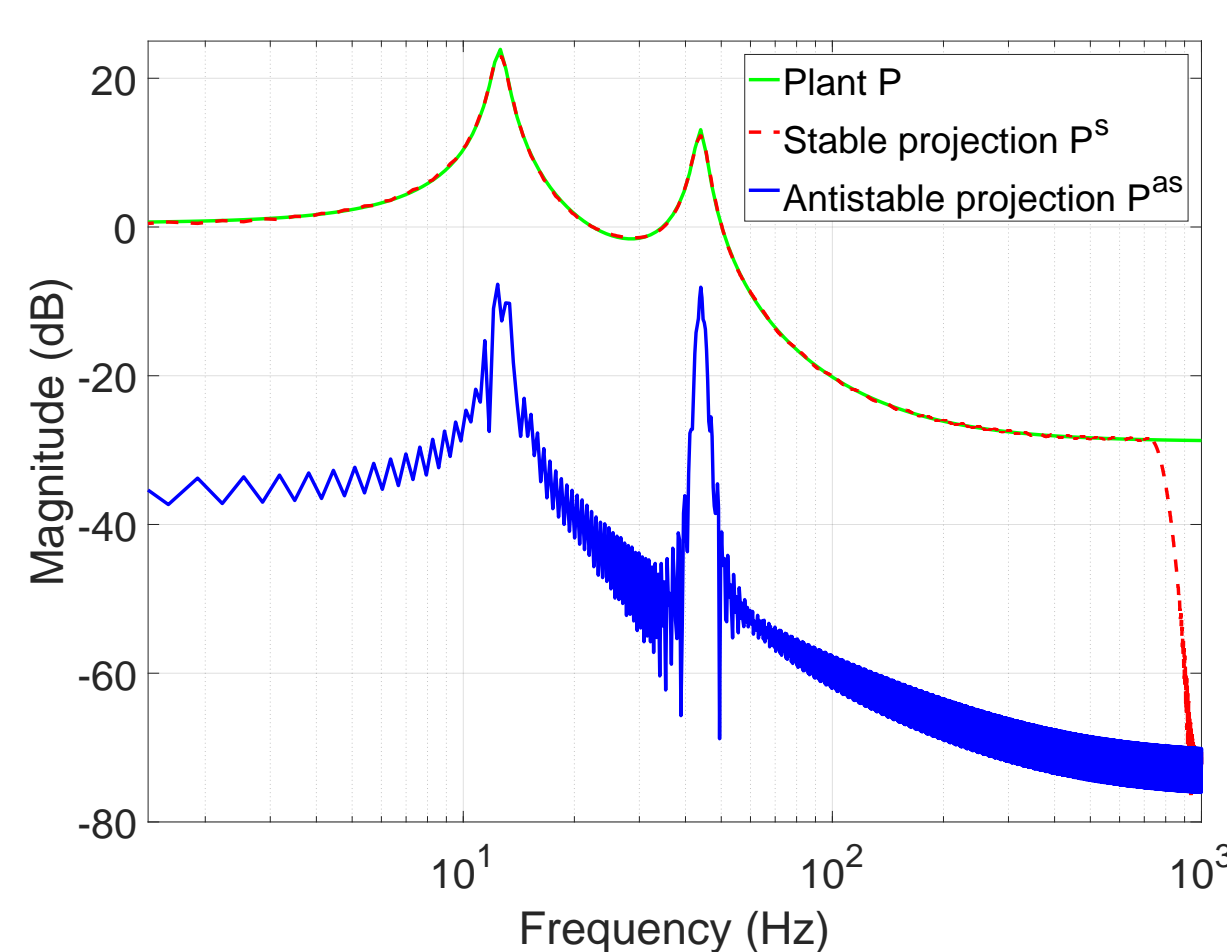

- 2) Principal Hankel Components technique to determine the number of NMP zeros and obtain an estimate of the instabilities.

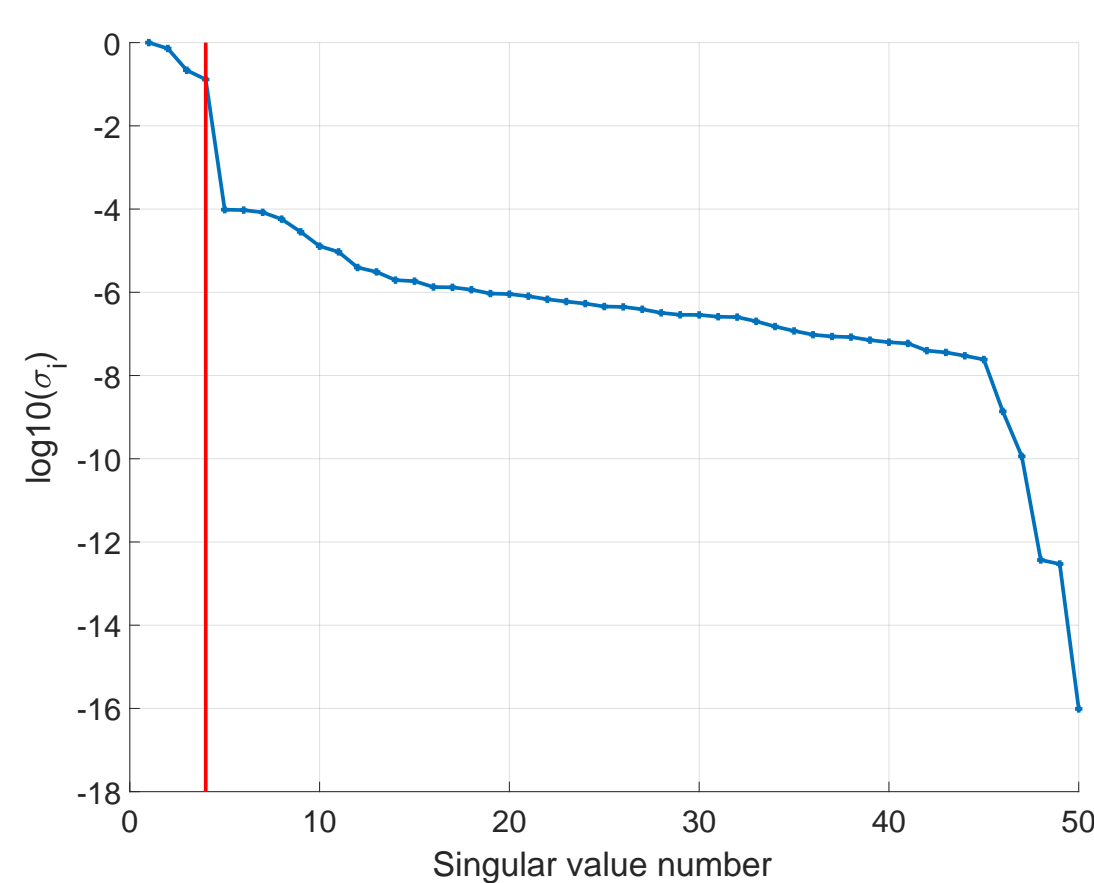

True z_i	Estimated \tilde{z}_i
140.5	140.58
40	41.3+2 <i>l</i>
40	41.3+2 <i>l</i>
40	37.4

- 3) Construction of an achievable reference model M_f .

$$M_f = MB_z$$

$$B_z(s) = \prod_{i=1}^{n_z} \frac{s - \tilde{z}_i}{s + \tilde{z}_i}$$

→ No more compensation of instabilities in the open-loop!

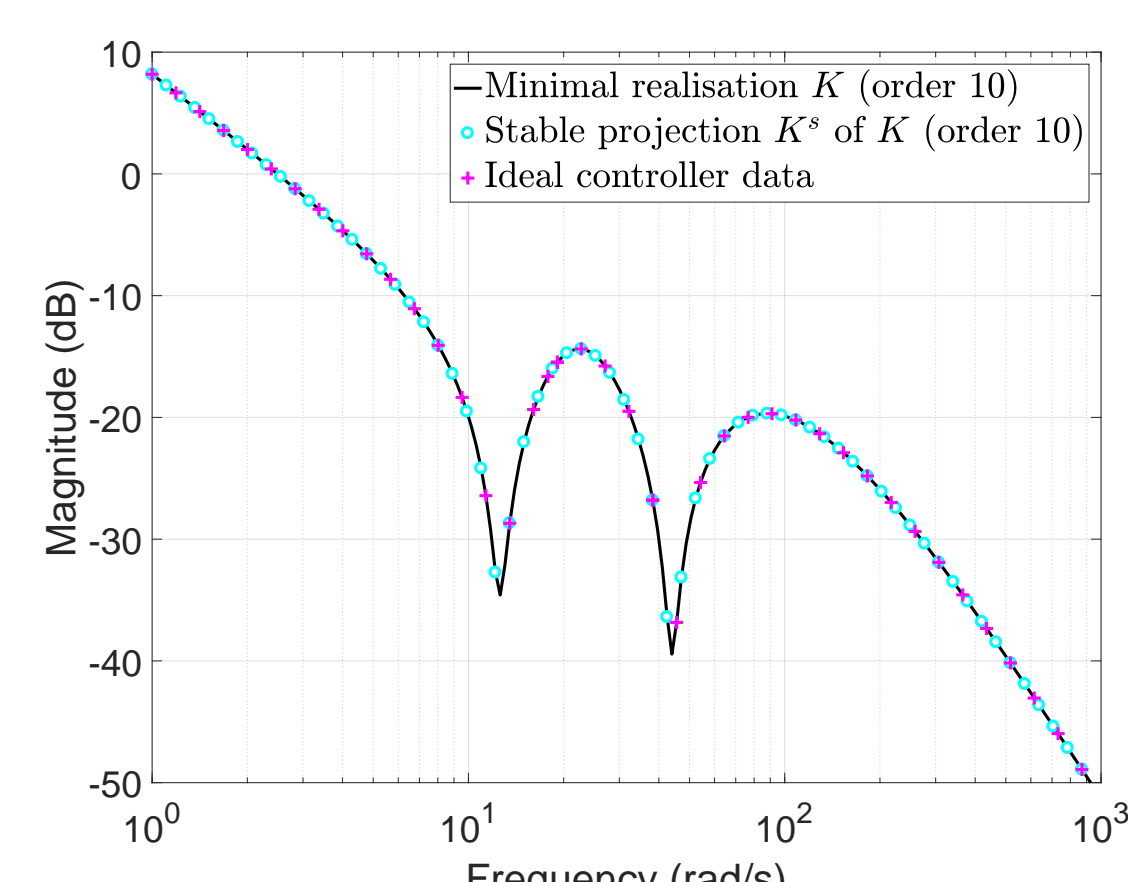

Data-driven closed-loop stability analysis

Controller modelling error Δ

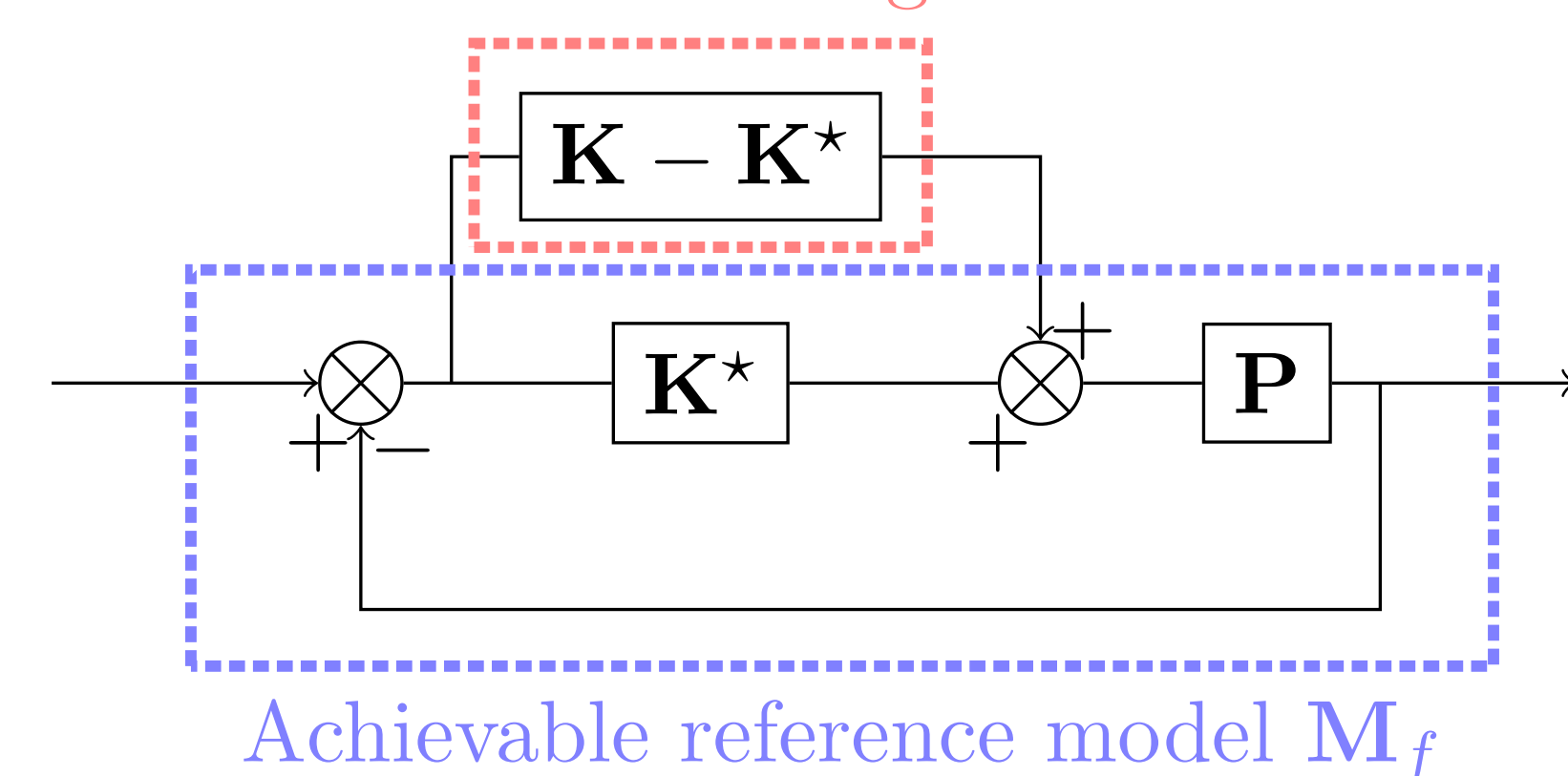

The interconnection is stable for all stable Δ such that $\|\Delta\|_\infty < \gamma$ iff $\|(1 - M_f)P\|_\infty \leq \gamma^{-1}$.

→ Maximal controller modelling error $\tilde{\gamma}^{-1} = \max_{i=1 \dots N} |(1 - M_f(j\omega_i))\Phi_i|$

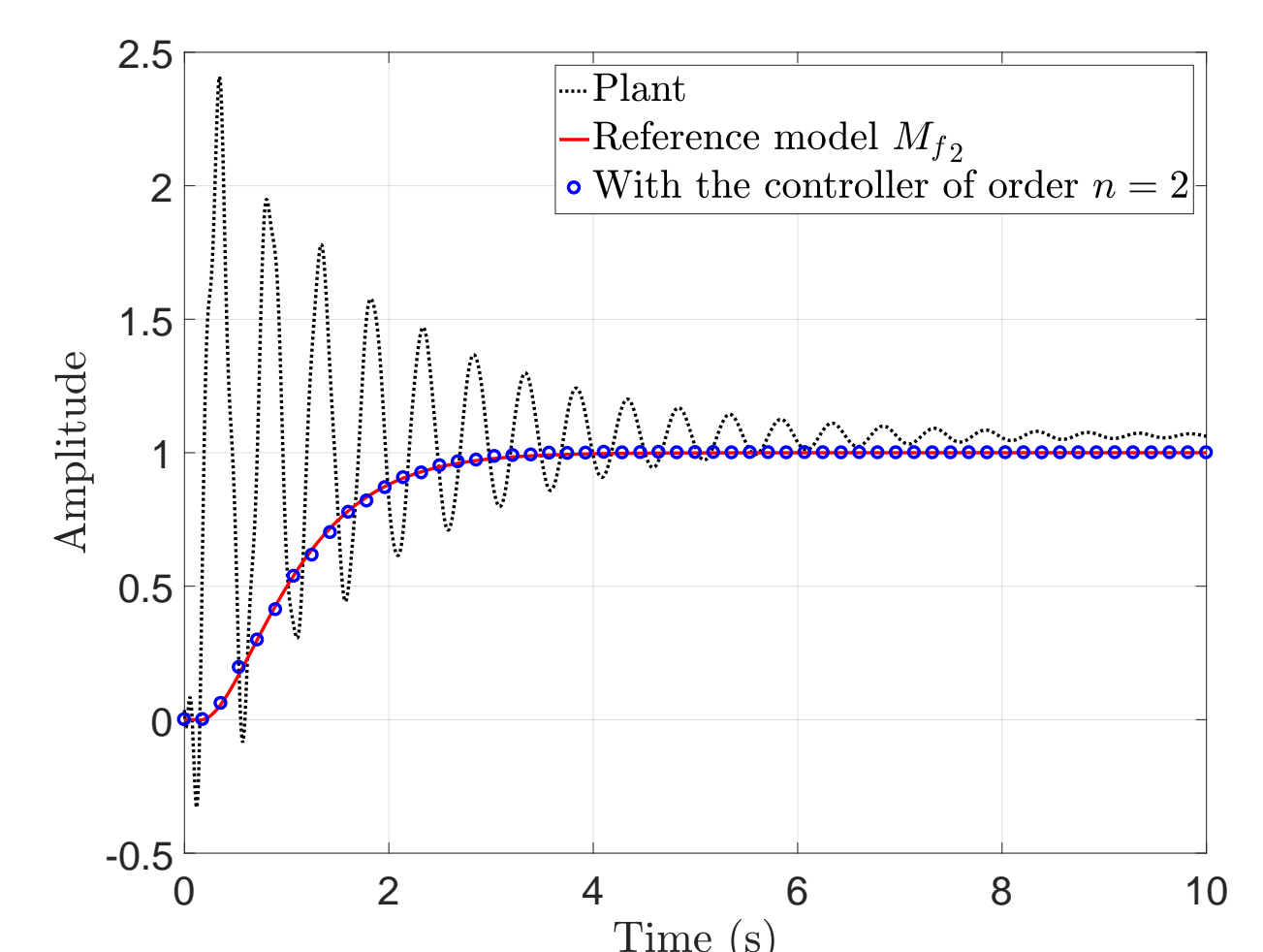
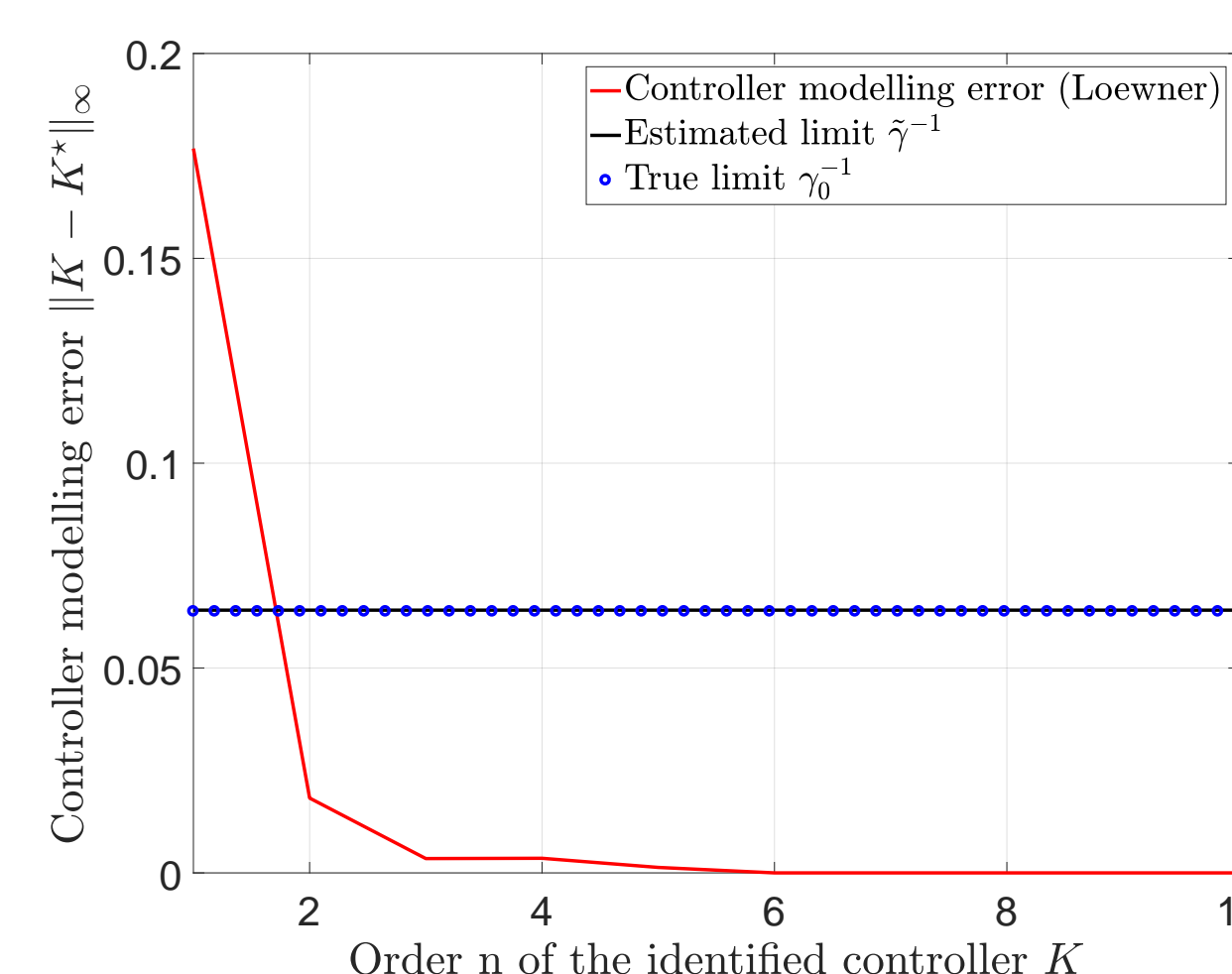

Conclusions and outlooks

- Data-driven technique taking into account the inherent performance limitations of the plant.
- The reduction of the controller is performed under a stability constraint.
- Need for a better data-driven estimation of the \mathcal{H}_∞ -norm.
- Too conservative stability test: possibility to use other stability indicators.

Bibliography

1. Kergus, P., Olivi, M., Poussot-Vassal, C., Demourant, F. (2019). *From reference model selection to controller validation: Application to Loewner Data-Driven Control*. IEEE Control Systems Letters.
2. Cooman, A., Seyfert, F., Olivi, M., Chevillard, S., Baratchart, L. (2017). *Model-free closed-loop stability analysis: A linear functional approach*. IEEE Transactions on Microwave Theory and Techniques, 66(1), 73-80.
3. Cooman, A., Seyfert, F., Amari, S. (2018). *Estimating unstable poles in simulations of microwave circuits*. IEEE/MTT-S International Microwave Symposium-IMS (pp. 97-100).
4. Van Heusden, K., Karimi, A., Bonvin, D. (2009). *Data-driven controller validation*. IFAC Proceedings Volumes, 42(10), 1050-1055