



HAL
open science

Does carbon dioxide storage by cyanobacteria induce biomineralization in presence of basaltic glass?

Thomas Ferrini, Olivier Grandjouan, Olivier Pourret, Raul E Martinez

► To cite this version:

Thomas Ferrini, Olivier Grandjouan, Olivier Pourret, Raul E Martinez. Does carbon dioxide storage by cyanobacteria induce biomineralization in presence of basaltic glass?. *Geochemical Journal -Japan-*, 2021, 55 (2), pp.51-58. 10.2343/geochemj.2.0617 . hal-03085925

HAL Id: hal-03085925

<https://hal.science/hal-03085925>

Submitted on 22 Dec 2020

HAL is a multi-disciplinary open access archive for the deposit and dissemination of scientific research documents, whether they are published or not. The documents may come from teaching and research institutions in France or abroad, or from public or private research centers.

L'archive ouverte pluridisciplinaire **HAL**, est destinée au dépôt et à la diffusion de documents scientifiques de niveau recherche, publiés ou non, émanant des établissements d'enseignement et de recherche français ou étrangers, des laboratoires publics ou privés.

1 **Does carbon dioxide storage by cyanobacteria induce**
2 **biomineralization in presence of basaltic glass?**

3
4
5 Thomas Ferrini¹, Olivier Grandjouan¹, Olivier Pourret^{1,#}, Raul E. Martinez^{2,*}

6
7 ¹UniLaSalle, AGHYLE, 19 rue Pierre Waguet, 60026 Beauvais cedex, France

8
9 ²Institut für Geowissenschaften, Universität Freiburg, Alberstraße 23b, 79104 Freiburg,
10 Germany

11
12
13
14
15
16 *Present address: Max Planck Institute for Biogeochemistry

17 #Corresponding author: olivier.pourret@unilasalle.fr.

24

25 **Abstract**

26 Cyanobacteria induced biomineralization of atmospheric CO₂ is a natural process leading to the
27 formation of carbonates by spontaneous precipitation or through the presence of nucleation
28 sites, under supersaturated conditions. As importance of basaltic rocks in the carbon cycle has
29 already been highlighted, basaltic glass was chosen to test its ability to release cations needed
30 for carbonate formation in presence of *Synechococcus* sp. cyanobacteria. Active cyanobacteria
31 were expected to generate a local alkaline environment through photosynthetic metabolism.
32 This process produces oxygen and hydroxide ions as waste products, raising the pH of the
33 immediate cell surface vicinity and indirectly enhancing the carbonate CO₃²⁻ concentration and
34 providing the a degree of saturation that can lead to the formation of calcite CaCO₃ or magnesite
35 MgCO₃. In the presence of active cells, the saturation index (SI) increased from -10.56 to -9.48
36 for calcite and from -13.6 to -12.5 for magnesite, however they remained negative due to the
37 low Ca²⁺ and Mg²⁺ activities. Dead cells were expected to act as nucleation sites by the stepwise
38 binding of carbonate with Ca²⁺ and Mg²⁺ on their surface. In the presence of inactive cells, SI
39 values were closer to 0 but still negative due to the low pH and cation concentrations. Our
40 results highlight that our current understanding of the carbon cycle suggests that Earth's climate
41 is stabilized by a negative feedback involving CO₂ consumption and especially during chemical
42 weathering of silicate minerals.

43

44 **Keywords:** biomineralization, cyanobacteria, basaltic glass, carbonate, saturation index,
45 critical zone

46 **1. Introduction**

47

48 The rise of CO₂ concentrations in the atmosphere is one of the most important
49 environmental problems on Earth today arising from anthropic activity (Gerlach, 2011). Carbon
50 storage methods, or carbon concentration mechanisms (CCM), need to be developed urgently
51 in order to reduce the CO₂ impact on Earth's terrestrial and aquatic environments. The ability
52 of cyanobacteria to induce the biomineralization of CO₂ is an option which is still in its infancy
53 and could possibly be used in the near-future to decrease atmospheric CO₂ levels (Martinez *et*
54 *al.*, 2016). Previous studies have proven the link between cyanobacteria photosynthesis and the
55 presence of metallic cations could lead to carbonate precipitation in the presence of atmospheric
56 CO₂ and under suitable solution conditions (Jansson and Northen, 2010; Martinez *et al.*, 2016;
57 Obst *et al.*, 2009).

58

59 Photosynthesis and CCM are the first steps to biomineralization of CO₂. Cyanobacteria
60 are autophototrophic microorganisms. They are primary producers, which generate their own
61 nutrients by carrying out the oxygenic photosynthesis (Martinez *et al.*, 2016). This metabolism
62 needs carbon as a source of inorganic carbon in the form of dissolved CO₂, natural light as
63 source of energy and water to provide electrons needed in the redox transformation of carbon
64 (Schubert *et al.*, 1997). The Calvin-Benson cycle permits the assimilation of the inorganic
65 carbon thanks to the initial CO₂-fixing-enzyme of photosynthesis: RuBisCO (Ribulose
66 Biphosphate Carbolxylase Oxygenase) (Fridlyand and Scheibe, 1999; Spreitzer and Salvucci,
67 2002). Chemical and photochemical reactions take place in photosystems located on the
68 thylakoid membrane of the cyanobacteria cell. ATP (Adenosine triphosphate) and NADPH
69 (Nicotinamide adenine dinucleotide phosphate) are chemical substances which permit CO₂
70 assimilation. A constant supply of inorganic carbon (IC) is required to carry out photosynthesis.

71 Dissolved CO₂, in the form of bicarbonate HCO₃⁻ is the inorganic form of carbon used by
72 cyanobacteria as an IC source. A metabolic system is used to attain inorganic carbon from the
73 aqueous environment. The CCM corresponds to an environmental adaptation of cyanobacteria,
74 it allows IC incorporation inside the cell in the form of HCO₃⁻ and convert it to CO₂ (Price *et*
75 *al.*, 2008). Molecules are attracted and stocked inside the cell with the help of IC transporters
76 located in both plasma and outer membranes. HCO₃⁻ transport is enhanced by the extra-ATP
77 generated during photosynthesis. The inorganic carbon is transported into the bacterial micro-
78 compartment where the bicarbonate molecules are transformed into CO₂ by the enzyme
79 carbonic anhydrase. The remaining CO₂ is then assimilated by the enzyme RuBisCO for
80 photosynthesis (Figure 1). A proton H⁺ is consumed by each of these reactions, leading to the
81 release of a hydroxide ion (OH⁻) outside the cell as a waste product along with O₂. This allows
82 the generation of an alkaline pH within the micro-environment around the cyanobacteria cell.
83 This alkaline pH permits the deprotonation of the external bicarbonate HCO₃⁻ to carbonate ions
84 CO₃²⁻. The presence of both metal cations (e.g. Ca²⁺/Mg²⁺) and carbonate (CO₃²⁻) allows the
85 nucleation of carbonates in the form of calcite (CaCO₃) and magnesite (MgCO₃) (Martinez *et*
86 *al.*, 2016; Riding, 2006). However, the amount of metal cations and carbonate must be high
87 enough to reach supersaturation with respect to these carbonate minerals.

88 In this study, basaltic glass was chosen as a source of metallic cations due to its
89 composition and abundance on the Earth's surface. Its importance in the carbon cycle has been
90 proven on several previous studies (Dessert *et al.*, 2003; Grimm *et al.*, 2019; Schlesinger and
91 Bernhardt, 2013; Schott *et al.*, 2012). A high rate of dissolution of basaltic glass would be
92 required to release significant metallic cation concentrations to achieve supersaturation with
93 respect to carbonate phases. Varying an electrolyte NaNO₃ background concentration has been
94 shown to affect the process of simple silicate mineral dissolution and the rate of release of
95 metallic cations as well as their activity (Martinez *et al.*, 2014; Martinez *et al.*, 2016). An

96 optimal concentration is needed in order to reach Ca^{2+} and Mg^{2+} activities, which together with
97 carbonate ion activities would lead to precipitation of carbonates. The *Synechococcus*
98 cyanobacteria species chosen for this study is representative of seawater cyanobacteria as along
99 with *Prochlorococcus* sp., it is responsible for approximately 30% of the photosynthesis on
100 Earth. *Synechococcus* sp. is a unicellular coccoid cyanobacteria containing outermost surface
101 layers but no cell covering sheath (Martinez *et al.*, 2010; Martinez *et al.*, 2008). The goal of this
102 study is to determine whether basaltic glass is an efficient source of metal cations needed for
103 CO_2 mineralization and then to quantify the rates of carbonate precipitation in presence of this
104 primary silicate and *Synechococcus* cyanobacteria species so that optimal conditions in terms
105 of basaltic glass dissolution and cyanobacteria biomass can be found.

106

107 **2. Material and methods**

108

109 A 20 mL aliquot of active *Synechococcus* sp. cyanobacteria stock at the stationary phase was
110 placed in a 5 L Schott® bottle. *Synechococcus* sp. cultures were grown in Cyanobacteria BG-
111 11 Freshwater Medium (Sigma-Aldrich C3061) for three weeks to stationary growth phase
112 (Martinez *et al.*, 2010). Active cyanobacteria stocks were prepared in order to achieve
113 photosynthesis in presence of basaltic glass (see bulk composition in Table 1), in order to
114 quantify the influence of cyanobacteria on the dissolution of the mineral could be observed and
115 the supersaturation conditions reached (see discussion on choice of experimental conditions in
116 Martinez *et al.*, 2010). Stock cultures of cyanobacteria were kept at room temperature ($23\pm 1^\circ\text{C}$)
117 under constant cool white fluorescent light illumination (5000 lx) and a constant filtered air
118 injection (3 L/min at around 400 ppm) in order to provide cyanobacteria with needed inorganic
119 carbon. The air inflow was used to keep the culture in a constant movement needed for optimal
120 growth. For each experiment, 5 L of 1/500 diluted cyanobacteria growth medium inoculated

121 with a 20 mL aliquot of regular 1/50 BG-11 (Table 2) cyanobacteria stock was placed on a
122 rotary shaker at 250 rpm (Martinez *et al.*, 2008). Dead cyanobacteria were prepared by
123 autoclaving an aliquot of active stock at 121°C for 20 min. To measure the exact cyanobacteria
124 mass, a 25 mL sample was collected. Vacuum filtration was used to filter the sample through a
125 0.2 µm pore size cellulose nitrate filter (Whatman®). The filtered sample was placed in an oven
126 at 60°C for 30 min and then weighed.

127

128 **2.1. Flow through open reactors system experimental design**

129

130 Basaltic glass dissolution experiments were performed at 23±1°C by mixing two different stock
131 solutions in flow through reactors with a peristaltic pump with a fixed inflow rate of 1.4 µL/min.
132 The active cyanobacteria and inorganic stocks solutions used are described in **Tables 2 and 3**.
133 To quantify the rates of basaltic glass and carbonate precipitation in presence of *Synechococcus*
134 *sp.* cyanobacteria, duplicate flow through reactors were used, each connected to the inorganic
135 and active cyanobacteria stocks by a peristaltic pump (Active cyanobacteria Flow Through open
136 reactor, AFT; **Table 2 and Figure 2**).

137 To assess the role of bio-mineralization by dead cells, a calcium chloride stock solution was
138 used instead of basaltic glass as the source of metal cations (e.g. Ca²⁺). For these experiments,
139 a flow through reactor was connected through the peristaltic pump to both the calcium chloride
140 and dead cyanobacteria stocks previously washed by centrifuging at 10,000 rpm for 20 min
141 (Calcium Flow Through reactor, CFT; **Table 3 and Figure 3**). Preliminary results and tests
142 are available in Ferrini and Grandjouan (2015). These dead cells act as nucleation sites. They

143 decrease the activation energy for precipitation, but saturation index (SI) values are not
144 influenced by the existence of nucleation sites (Martinez *et al.*, 2008).

145 For all experiments, Tygon R 3603 tubes were used to link both stocks to 200 mL flow through
146 reactors with the help of a 4 channel peristaltic pump with a low flow rate of 1.4 $\mu\text{L}/\text{min}$.

147

148 **2.2. Sample analysis**

149

150 In order to monitor the chemical evolution and the cyanobacteria biomass concentration of the
151 solution inside the flow through reactor, the pH, conductivity, alkalinity, optical density, and
152 Ca^{2+} and Mg^{2+} concentrations were measured from samples collected in 50 mL polypropylene
153 Falcon® tubes from the output of the flow through reactors, once daily. Time zero was taken
154 to be the time of this first sampling of the flow through reactor solution (Martinez *et al.*, 2016).
155 Reactors were placed in a water bath at 22°C in order to keep their contents solutions at a
156 constant temperature. A 20 mL sample was taken from each reactor for all experiments. An
157 aliquot of 7 mL of sample was used to measure the optical density of the solution at 750 nm
158 wavelength, to approximate the concentration of cyanobacteria biomass over time. The
159 remaining 13 mL were used to measure pH, total alkalinity and conductivity. The pH and
160 alkalinity were measured with an automatic titration system (Metrohm® 719 Titrino automatic
161 titrator). In this study, dominated by the presence of dissolved CO_2 , the total alkalinity (TA)
162 provides an estimate of the concentrations of bicarbonate and carbonate species in solution. The
163 TA is determined through an acid titration (alkalinity titration) where the final concentration of
164 the acid, at the second end-point of the carbonate system, $\text{pH} = 4.3$, represents the total alkalinity
165 of the solution. Carbonate alkalinity (CA) is determined by driving the alkalinity titration to the

166 first end-point for the carbonate system at pH = 8.3. From the carbonate alkalinity, the CO₃²⁻
167 concentration in solution, which is part of total alkalinity, can be determined:

$$168 \quad TA = [HCO_3^-] + 2 [CO_3^{2-}] + [OH^-] - [H^+] \quad (1a)$$

$$169 \quad CA = 2 [CO_3^{2-}] + [OH^-] \quad (1b)$$

170 As [CO₃²⁻], [H⁺] and [OH⁻] are negligible for neutral to alkaline pH conditions (between 6 and
171 11), total alkalinity can be re-defined to:

172

$$173 \quad TA = [HCO_3^-] \quad (2)$$

174

175 Ca²⁺ and Mg²⁺ concentrations were measured by flame atomic adsorption spectroscopy (F-
176 AAS) with an Analytik Jena Vario 6 flame atomic adsorption spectrometer. The conductivity
177 of sample aliquots was measured using a WTW LF 325 conductivity meter where conductivity
178 is measured in mS/cm (Harris, 2010). Conductivity measurements for a particular solution
179 allow calculation of the ionic strength (IS). The IS is proportional to the concentration of all
180 dissolved salts in a solution. The ionic strength is required to calculate cation activity (ac) as
181 shown below:

$$182 \quad ac = [C]\gamma_C \quad (3)$$

183 where [C] is the species concentration and γ_C is the activity coefficient. The log₁₀ of γ_C can be
184 calculated as per the Debye-Hückel equation Eq. 4 as a function of the solution IS determined
185 from conductivity measurements:

$$186 \quad \log \gamma_C = (-0.51 * z^2 * \sqrt{IS}) / (1 + (\alpha * \sqrt{IS} / 305)) \quad (4)$$

187 where z represents the charge of the ion (e.g. for Mg²⁺, z=2), α the radius of the ion in picometers
188 (e.g. for Ca²⁺, $\alpha_{Ca^{2+}} = 600$ pm) (Harris, 2010; Stumm and Morgan, 1996).

189 To predict the formation of carbonate phases in this study, it is first necessary to quantify the
190 degree of solution supersaturation with respect to Ca or Mg carbonates. This requires
191 knowledge of the saturation index for each of these mineral phases. However, calculation of
192 saturation state is first necessary. The saturation state (Ω) represents the degree of saturation of
193 a solution with respect to a particular mineral phase (Langdon *et al.*, 2000) and is defined as
194 follows:

$$195 \quad \Omega = (aCa^{2+} * aCO_3^{2-}) / K_{sp} \quad (5)$$

196 Where K_{sp} is the solubility product of the mineral phase that can potentially form in solution
197 (e.g. for calcite, $K_{sp}=10^{-8.48}$) and, aCa^{2+} and aCO_3^{2-} are the activities of Ca^{2+} and CO_3^{2-}
198 respectively. The SI is then defined as:

$$199 \quad SI = \log_{10}(\Omega) \quad (6)$$

200 A positive value of SI indicates supersaturation with respect to a mineral phase and suggests
201 that precipitation of the mineral would occur. However this depends further on solution
202 conditions (e.g. mineral nucleation, spontaneous nucleation/precipitation) (Langdon *et al.*,
203 2000).

204

205 **3. Results**

206

207 Temporal evolution of the pH, the total alkalinity and the cations concentrations has been
208 measured. These values were used to calculate saturation index with respect to calcite and
209 magnesite. Related values for AFT and CFT are presented in Figures 4 and 5 and Figures 6 and
210 7, respectively. For all conditions, experiments were carried out in duplicates.

211

212 **3.1. Active cyanobacteria Flow Through open reactor results**

213

214 In this experiments, the pH remained alkaline, starting at 10.9 ± 1 and declining until a pH of
215 10.1 at 150 h (Figure 4). Total alkalinity increased from 1 mmol/L to 1.8 mmol/L in 242 h for
216 both reactors (Figure 4). $[Ca^{2+}]$ and $[Mg^{2+}]$ remained constant for the duration of the
217 experiments at an average of 3.37 ± 1.00 mg/L for $[Ca^{2+}]$ and 3.28 ± 0.44 mg/L for $[Mg^{2+}]$.
218 A slight decrease in these concentrations was observed for the experiment in the first reactor.
219 SI values for both calcite and magnesite remained negative for the time of the experiment. The
220 $SI_{(calcite)}$ increased from -10.6 to -9.4 over a period of 145 h whereas the $SI_{(magnesite)}$ raised from
221 -13.6 to -12.5 (Figure 5). Both SI curves reached a constant threshold at 150 h.

222

223 **3.2. Calcium Flow Through reactor results**

224

225 The pH and the total alkalinity increased through the 300 h of the experiments. A total alkalinity
226 of 0.2 mmol/L was recorded at the start of experiments to reach a final value of 0.75 mmol/L
227 (Figure 6). The pH was for the most part neutral but raised from 6.3 to a last value of 6.75

228 (Figure 6). The calcium chloride used permitted to obtain a rather constant $[Ca^{2+}]$ concentration
229 at an average of 280 mg/L. The calculated $SI_{(calcite)}$ is negative but close to the solution
230 supersaturation with respect to calcite. These values are remained within the range of -4.6 to -
231 4.9 for the duration of the experiment (Figure 7).

232

233 4. Discussion

234

235 None of both experiments could achieve supersaturation state with respect to calcite or
236 magnesite. The SI remain negative but fluctuate as a function of the pH, the cation concentration
237 and the total alkalinity. This confirms that saturation index depends on metal cations and CO_3^{2-}
238 activities and further suggests the inability of basaltic glass dissolution to provide the necessary
239 amount of cations required for solution supersaturation with respect to carbonates. The AFT
240 experiment shows constant $[\text{Ca}^{2+}]$ and $[\text{Mg}^{2+}]$ concentrations (see details in Ferrini and
241 Grandjouan (2015)). In this case an increase in the CO_3^{2-} activity would be required to achieve
242 supersaturated conditions with respect to carbonate, this would be reflected in a positive value
243 of the SI for these mineral phases. As the concentration of cations remained constant, a higher
244 concentration of carbonate or a higher degree of bicarbonate deprotonation from a higher pH
245 would be required. This means an enhanced deprotonation of bicarbonate HCO_3^- and the
246 consumption of hydroxide ion (OH^-). This then explains the decreasing pH and the increasing
247 total alkalinity as per eq.1. According to the previously mentioned definition of the carbonate
248 alkalinity a pH higher than 8.3 would be required in order to induce bicarbonate ion
249 deprotonation for production of CO_3^{2-} in significant concentrations (Stumm and Morgan, 1996).
250 A higher pH could be reached by active cyanobacteria. Indeed, cyanobacteria consume
251 bicarbonate ions by photosynthesis which leads to the higher pH values, the formation of
252 carbonate (CO_3^{2-}) and a raising SI in the presence of sufficient metal cations for supersaturation
253 In the CFT case, increasing pH rates can be explained by the presence of dead cyanobacteria
254 mass and their interaction of their deprotonated cell surface groups with dissolving CO_2 from
255 air injection (Weber and Martinez, 2017). However, SI remains negative because of the near-
256 neutral pH which prevents calcite precipitation as bio-mineralization needs a pH higher than
257 8.3 to commence the generation of carbonate ions.

258 It has been shown that active cyanobacteria have a protective mechanism against carbonate
259 precipitation on their surface, which is missing for dead cyanobacteria implying that this is the
260 consequence of the metabolic activity of these primary producers (Martinez *et al.*, 2010;
261 Martinez *et al.*, 2008). Dead cyanobacteria cells or cellular debris may act as nucleation sites
262 by binding Ca^{2+} and Mg^{2+} cations on their surface. This could explain why the SI results become
263 less negative in the CFT experiment in presence of dead cells. There are two mechanisms of
264 mineral precipitation which are favored depending on the degree of solution supersaturation
265 with respect to a particular mineral. In our study, we did not observe supersaturation with
266 respect to carbonate minerals, nor the conditions for spontaneous nucleation of these minerals,
267 a process that takes place saturation state values equal or in excess of 3 to 4. However, the
268 existence of nucleation sites, does decrease the activation energy for precipitation, therefore
269 affecting the saturation index for a particular mineral, not in the bulk solution, but in the
270 microenvironment of dead cell surfaces, for example, where the value of the SI for a specific
271 carbonate mineral may be enhanced due to the higher concentration of metal cations and
272 carbonate, near the negatively charged reactive solid surface. Therefore, the presence of both
273 active and dead cyanobacteria, as in the natural environment, contributes to controlling the
274 mode of carbonate mineral precipitation, through the generation of an alkaline pH or due to the
275 efficient sorption of metal cations leading to the nucleation of mineral phases (Martinez *et al.*,
276 2010; Martinez *et al.*, 2016; Weber and Martinez, 2017).

277 Another important factor which is needed for supersaturation is the metal cations
278 concentrations. CFT results proved that high metal cation concentrations from an efficiently
279 dissolving source, such as calcium chloride, lead to SI values which are closer to solution
280 supersaturation with respect to carbonates. AFT [Ca^{2+}] and [Mg^{2+}] concentrations from basaltic
281 glass dissolution were insufficient to achieve carbonate precipitation. Indeed, a solution needs
282 to be supersaturated with respect to a particular mineral in order for it to precipitate. Therefore,

283 the precipitation of carbonate minerals will depend not only on the metal cation activity but
284 also on the carbonate activity. In our results the pH of the solutions was low, therefore we
285 observed a low carbonate activity and a slight release of metal cations from the basaltic glass.
286 Therefore, both of these aspects did not allow the ion activity product of metal cation and
287 carbonate in solution, to exceed the solubility product for carbonate minerals. This implies that
288 the use of basaltic glass for carbonation and CO₂ mineralization would be inefficient if
289 employed at large scale, requiring the use of faster dissolving simple silicate minerals such as
290 olivine, or finding a way to enhance the release of metal cations from simple and more
291 complicated alumino-silicate minerals. The slight decrease in metal cation concentrations in
292 these experiments, occasionally observed, can be explained by the need for more testing and
293 development of the flow through reactor used, where a fast flow rate would cause dilution of
294 metal cations. A slower pump rate would have to be used. Moreover, higher metal cation
295 dissolution rates would have to be reached, however, another silicate mineral would need to be
296 tested which can release metal cations at a faster rate. The background electrolyte concentration
297 of 0.04 mol/L NaNO₃ could be modified in order to find the optimal concentration and optimize
298 the dissolution rate and the metal cation activities. Smaller basaltic glass particles can be used,
299 this would produce and increase mineral surface area which would lead to an increase in the
300 basaltic glass dissolution rate.

301 As proposed on Figure 1, parameters which could contribute to achieving supersaturation state
302 with respect to carbonates and subsequent precipitation in the presence of cyanobacteria are
303 highlighted. As evidenced by our study, several points have to be improved in order to achieve
304 carbonate nucleation and precipitation. *Synechococcus* cyanobacteria have to be grown in
305 proper conditions with enough space and time to get to cell population saturation (at least 2
306 weeks). Active cells lead to an alkaline (high pH) environment by the photosynthesis process,
307 and indirectly to the formation of carbonate CO₃²⁻. The “flow through reactor” open system

308 permits a constant CO₂ supply and other nutrients required for photosynthesis and cell growth.
309 On another hand, basaltic glass has to be dissolved in optimal conditions so as to reach high
310 aqueous [Ca²⁺] and [Mg²⁺] concentrations. Providing all these conditions, calcite or magnesite
311 precipitation could be expected in the flow through reactors. Using the rate model in Eq.11 an
312 approximation of the total carbonate precipitation amount could be calculated for potential
313 implementation of these systems at the larger scale. Scanning electron microscopy and energy-
314 dispersive X-ray spectroscopy analyses could then help to the analysis and identification of
315 carbonates to confirm the presence of calcite or aragonite polymorphs or that of magnesite. By
316 finding optimal conditions for cyanobacteria induced bio-mineralization, this method could be
317 used to stock significant quantities of CO₂ at a large scale.

318 Overall, our results highlight that our current understanding of the long-term carbon cycle
319 suggests that Earth's climate is stabilized by a negative feedback involving CO₂ consumption
320 and especially during chemical weathering of silicate minerals (Penman *et al.*, 2020).

321

322 **Acknowledgments**

323 The authors would like to thank the Institut Polytechnique UniLaSalle, for funding part of this
324 study and T.F. and O.G. bachelor thesis. In addition the authors would like to thank Ms. Sigrid
325 Hirth-Walther of the Institute of Geosciences at the University of Freiburg for F-AAS
326 measurements, Dr. Petru Jitaru of Institut Polytechnique UniLaSalle for ICP-MS analysis.
327 Furthermore, the authors would like to extend their gratitude to Dr. Christian Grimm and Dr.
328 Eric H. Oelkers of the GET-CNRS in Toulouse, France, for providing the basaltic glass samples
329 used in this study. Eventually, we thank Dr. Daniel E. Ibarra for insightful review of the
330 manuscript.

331

332 **References**

- 333 Dessert, C., Dupré, B., Gaillardet, J., François, L. M. and Allègre, C. J. (2003) Basalt weathering laws
 334 and the impact of basalt weathering on the global carbon cycle. *Chem. Geol.* **202**, 257-273.
- 335 Ferrini, T. and Grandjouan, O. (2015) CO₂ storage by cyanobacteria induced biomineralization in
 336 presence of basaltic glass. Bachelor.
- 337 Fridlyand, L. E. and Scheibe, R. (1999) Regulation of the Calvin cycle for CO₂ fixation as an example
 338 for general control mechanisms in metabolic cycles. *Biosystems.* **51**, 79-93.
- 339 Gerlach, T. (2011) Volcanic versus anthropogenic carbon dioxide. *Eos, Transactions American*
 340 *Geophysical Union.* **92**, 201-202.
- 341 Grimm, C., Martinez, R. E., Pokrovsky, O. S., Benning, L. G. and Oelkers, E. H. (2019) Enhancement
 342 of cyanobacterial growth by riverine particulate material. *Chem. Geol.* **525**, 143-167.
- 343 Harris, D. C. (2010) *Quantitative Chemical Analysis, Eight Edition.* MacMillan Publishing
- 344 Jansson, C. and Northen, T. (2010) Calcifying cyanobacteria—the potential of biomineralization for
 345 carbon capture and storage. *Current Opinion in Biotechnology.* **21**, 365-371.
- 346 Langdon, C., Takahashi, T., Sweeney, C., Chipman, D., Goddard, J., Marubini, F., Aceves, H., Barnett,
 347 H. and Atkinson, M. J. (2000) Effect of calcium carbonate saturation state on the calcification
 348 rate of an experimental coral reef. *Global Biogeochem. Cy.* **14**, 639-654.
- 349 Martinez, R. E., Gardés, E., Pokrovsky, O. S., Schott, J. and Oelkers, E. H. (2010) Do photosynthetic
 350 bacteria have a protective mechanism against carbonate precipitation at their surfaces?
 351 *Geochim. Cosmochim. Acta.* **74**, 1329-1337.
- 352 Martinez, R. E., Pokrovsky, O. S., Schott, J. and Oelkers, E. H. (2008) Surface charge and zeta-potential
 353 of metabolically active and dead cyanobacteria. *J. Colloid Interface Sci.* **323**, 317-325.
- 354 Martinez, R. E., Weber, S. and Bucher, K. (2014) Quantifying the kinetics of olivine dissolution in
 355 partially closed and closed batch reactor systems. *Chem. Geol.* **367**, 1-12.
- 356 Martinez, R. E., Weber, S. and Grimm, C. (2016) Effects of freshwater *Synechococcus* sp. cyanobacteria
 357 pH buffering on CaCO₃ precipitation: Implications for CO₂ sequestration. *Appl. Geochem.* **75**,
 358 76-89.
- 359 Obst, M., Wehrli, B. and Dittrich, M. (2009) CaCO₃ nucleation by cyanobacteria: laboratory evidence
 360 for a passive, surface-induced mechanism. *Geobiology.* **7**, 324-347.
- 361 Penman, D. E., Caves Rugenstein, J. K., Ibarra, D. E. and Winnick, M. J. (2020) Silicate weathering as
 362 a feedback and forcing in Earth's climate and carbon cycle. *Earth-Science Reviews.* **209**,
 363 103298.
- 364 Price, G. D., Badger, M. R., Woodger, F. J. and Long, B. M. (2008) Advances in understanding the
 365 cyanobacterial CO₂-concentrating-mechanism (CCM): functional components, Ci transporters,
 366 diversity, genetic regulation and prospects for engineering into plants. *Journal of Experimental*
 367 *Botany.* **59**, 1441-1461.
- 368 Riding, R. (2006) Cyanobacterial calcification, carbon dioxide concentrating mechanisms, and
 369 Proterozoic–Cambrian changes in atmospheric composition. *Geobiology.* **4**, 299-316.
- 370 Schlesinger, W. H. and Bernhardt, E. S. (2013) Chapter 5 - The Biosphere: The Carbon Cycle of
 371 Terrestrial Ecosystems. *Biogeochemistry (Third Edition)* (Schlesinger, W. H. and Bernhardt, E.
 372 S. eds.), 135-172, Academic Press.
- 373 Schott, J., Pokrovsky, O. S., Spalla, O., Devreux, F., Gloter, A. and Mielczarski, J. A. (2012) Formation,
 374 growth and transformation of leached layers during silicate minerals dissolution: The example
 375 of wollastonite. *Geochim. Cosmochim. Acta.* **98**, 259-281.
- 376 Schubert, W.-D., Klukas, O., Krauß, N., Saenger, W., Fromme, P. and Witt, H. T. (1997) Photosystem
 377 I of *Synechococcus elongatus* at 4 Å resolution: comprehensive structure analysis. *Journal of*
 378 *Molecular Biology.* **272**, 741-769.
- 379 Spreitzer, R. J. and Salvucci, M. E. (2002) RUBISCO: Structure, Regulatory Interactions, and
 380 Possibilities for a Better Enzyme. *Annual Review of Plant Biology.* **53**, 449-475.
- 381 Stumm, W. and Morgan, J. J. (1996) *Aquatic Chemistry.* Wiley Intersciences
- 382 Weber, S. and Martinez, R. E. (2017) Effects of *Synechococcus* sp. cyanobacteria inert biomass on
 383 olivine dissolution: Implications for the application of enhanced weathering methods. *Appl.*
 384 *Geochem.* **84**, 162-172.

385

386

387 **Table 1** Bulk composition of basaltic glass

Element	Unit	Concentration
SiO ₂	%	47.49
Al ₂ O ₃	%	14.06
Fe ₂ O ₃	%	13.51
MgO	%	9.38
CaO	%	11.62
Na ₂ O	%	1.85
K ₂ O	%	0.28
TiO ₂	%	1.53
P ₂ O ₅	%	0.17
MnO	%	0.2
Cr ₂ O ₃	%	0.086

388

389

390

391

392 **Table 2** Composition of flow through reactors initial solution for AFT experiment.

5L of active cyanobacteria stock	
Reagent	Quantity
aliquot BG-11	10 mL
<i>Synechococcus</i> sp. at the stationary phase	20 mL
NaNO ₃	0.04 mol/L
MgSO ₄	0.003 mol/L
"Inorganic" stock	
Basaltic glass	20 g
NaNO ₃	0.04 mol/L
MgSO ₄	0.003 mol/L

393

394

395 **Table 3** Composition of flow through reactors initial solution for CFT experiment.

5 L dead cyanobacteria "autoclaved" stock	
Reagent	Quantity
Active cyanobacteria "autoclaved"	
(20 min at 121°C)	60 mL
NaNO ₃	0.04 mol/L
MgSO ₄	0.003 mol/L
Calcium chloride stock	
CaCl	0.09 mol/L
NaNO ₃	0.04 mol/L
MgSO ₄	0.003 mol/L

Figure captions

Figure 1 Schematic interpretation of optimal conditions leading to cyanobacteria induced bio-mineralization in presence of basaltic glass.

Figure 2 Active cyanobacteria Flow Through open reactor (AFT) experimental set up.

Figure 3 Calcium Flow Through reactor (CFT) experimental set up.

Figure 4 Evolution of pH and total alkalinity through time experiment (0.04 mol/L NaNO₃; AFT experiment 2). Experiment was duplicated between 0 and 120 h.

Figure 5 Evolution of saturation index through time experiment (0.04 mol/L NaNO₃; AFT experiment 2).

Figure 6 Evolution of pH and total alkalinity through time experiment (0.04 mol/L NaNO₃; CFT experiment).

Figure 7 Evolution of Saturation index through time experiment (0.04 mol/L NaNO₃; CFT experiment).

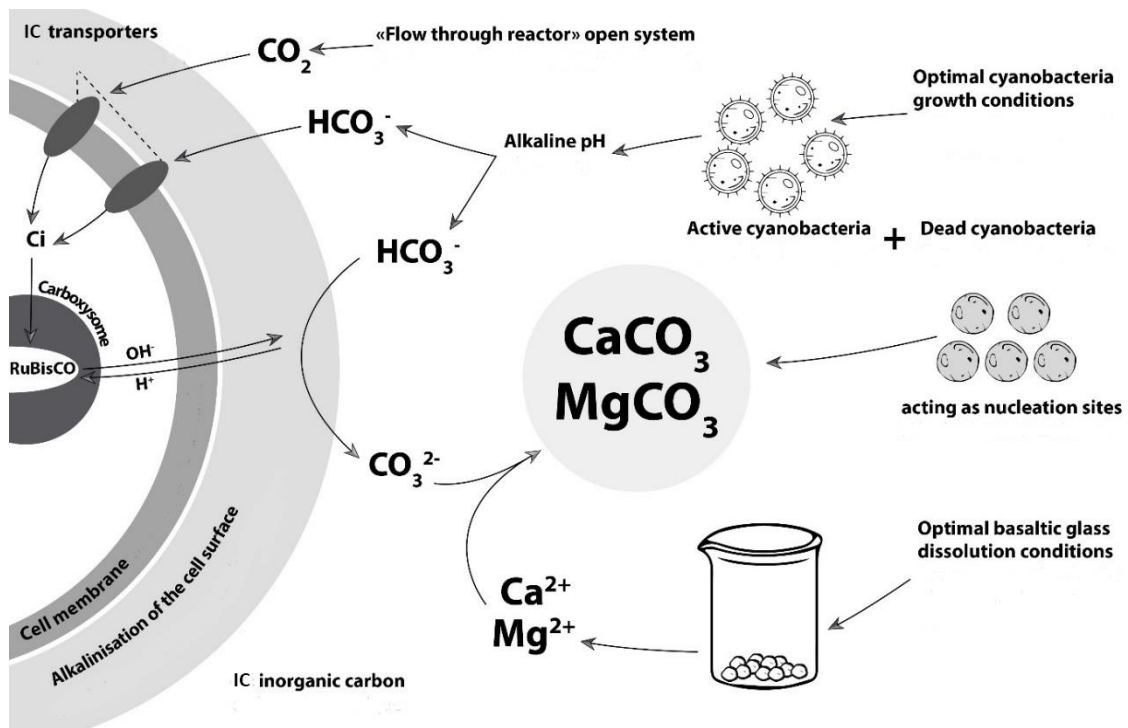

Figure 1

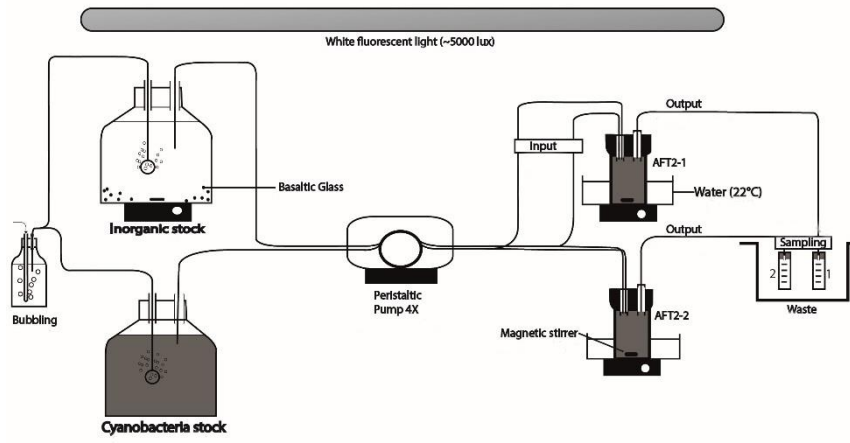

Figure 2

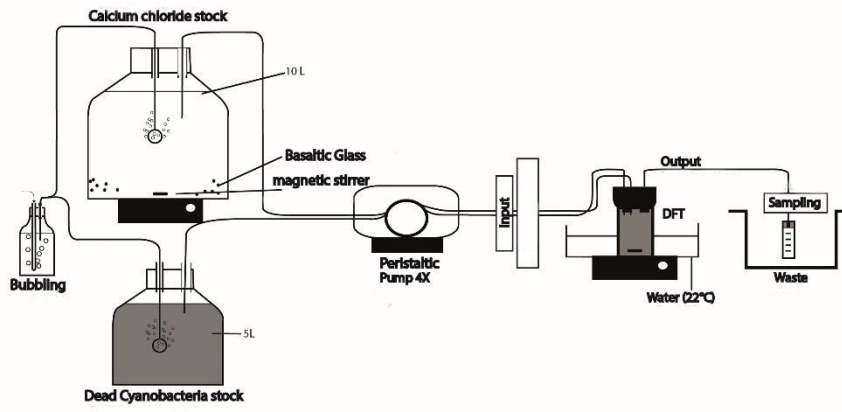

Figure 3

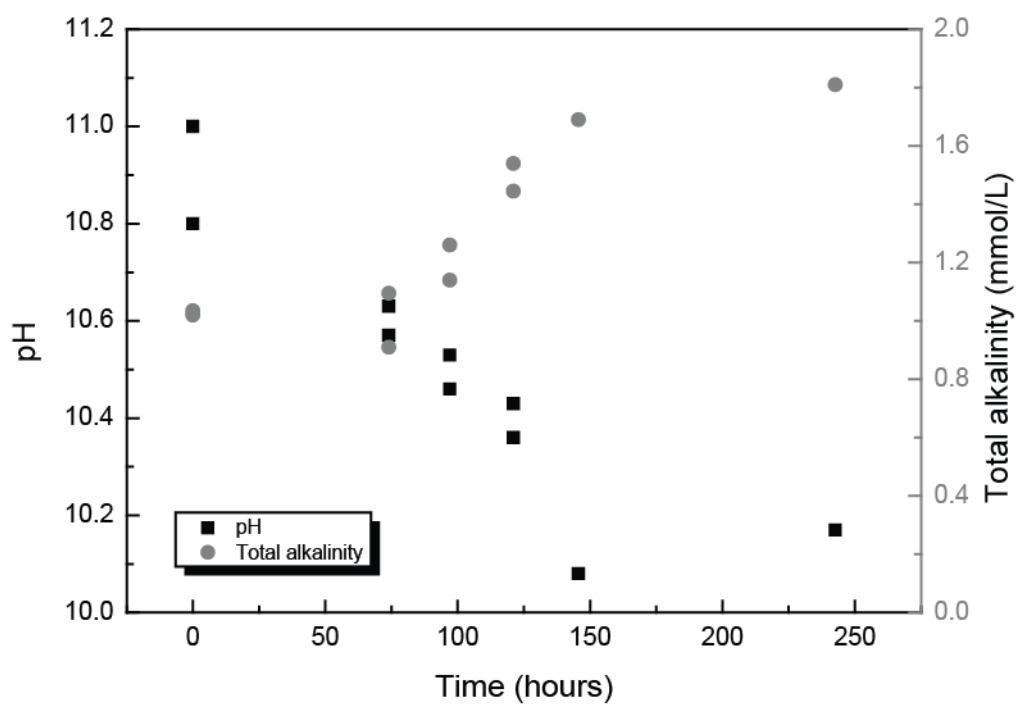

Figure 4

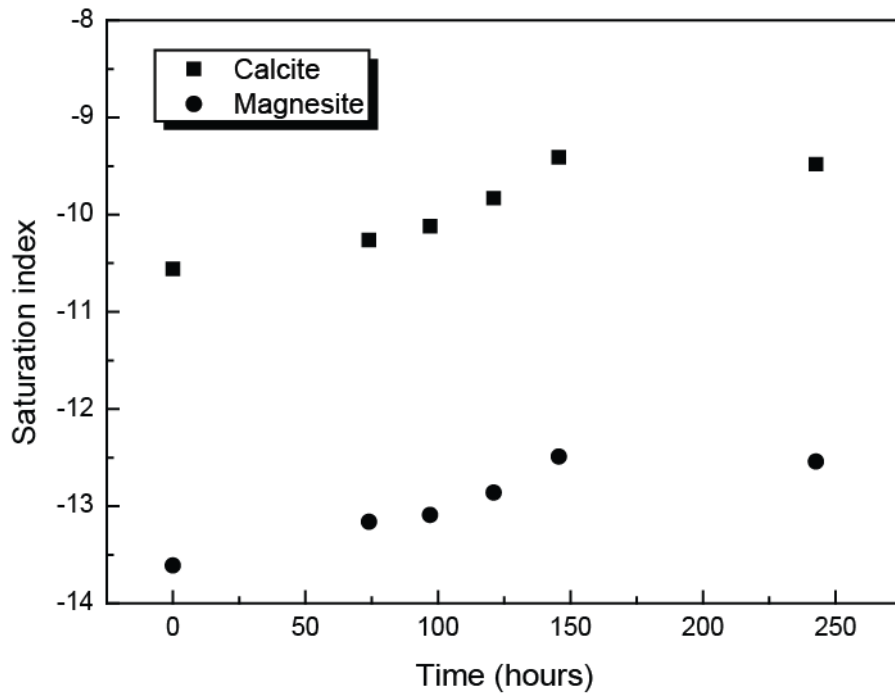

Figure 5

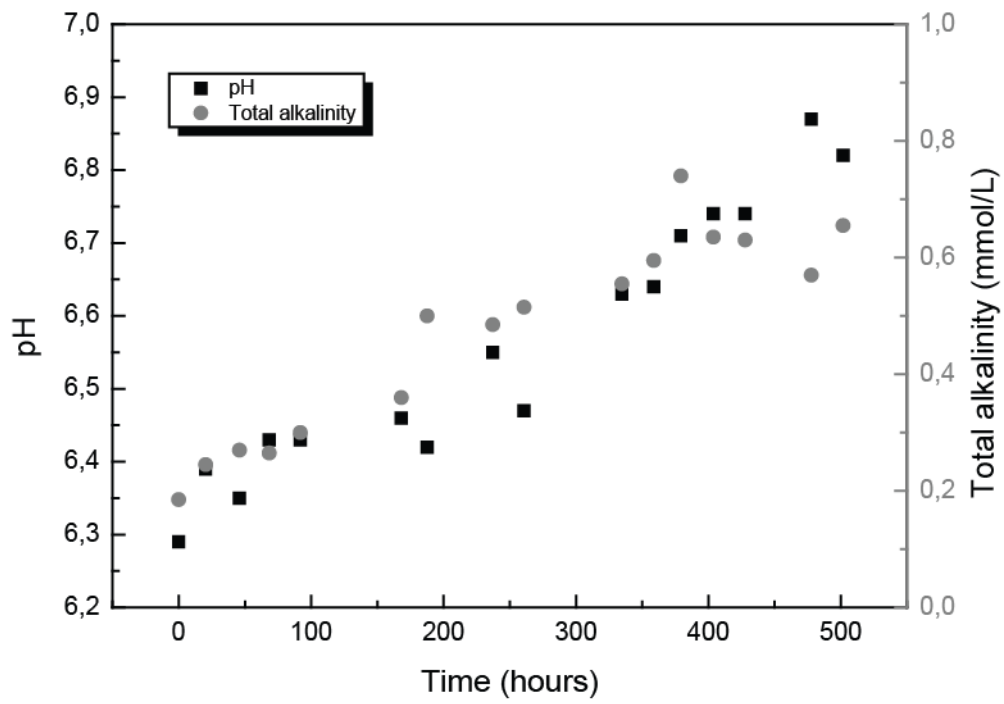

Figure 6

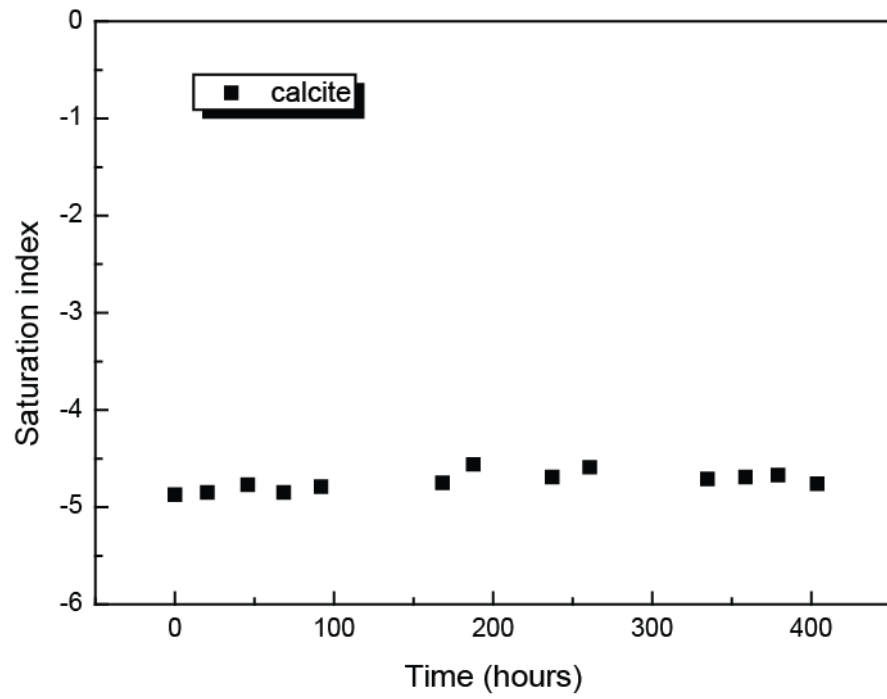

Figure 7