



HAL
open science

The Dikpālas of ancient Java revisited: A new identification for the 24 directional deities on the Śiva temple of the Loro Jonggrang complex

Andrea Acri, Roy Jordaan

► **To cite this version:**

Andrea Acri, Roy Jordaan. The Dikpālas of ancient Java revisited: A new identification for the 24 directional deities on the Śiva temple of the Loro Jonggrang complex. *Bijdragen tot de taal-, land- en volkenkunde / Journal of the Humanities and Social Sciences of Southeast Asia*, 2012, 168 (2-3), pp.274-313. 10.1163/22134379-90003562 . hal-03060462

HAL Id: hal-03060462

<https://hal.science/hal-03060462v1>

Submitted on 20 Dec 2022

HAL is a multi-disciplinary open access archive for the deposit and dissemination of scientific research documents, whether they are published or not. The documents may come from teaching and research institutions in France or abroad, or from public or private research centers.

L'archive ouverte pluridisciplinaire **HAL**, est destinée au dépôt et à la diffusion de documents scientifiques de niveau recherche, publiés ou non, émanant des établissements d'enseignement et de recherche français ou étrangers, des laboratoires publics ou privés.



Distributed under a Creative Commons Attribution - NonCommercial 4.0 International License

ANDREA ACRI AND ROY JORDAAN

The Dikpālas of ancient Java revisited

A new identification for the 24 directional deities on the Śiva temple of the Loro Jonggrang complex

Introduction

Caṅḍi Śiva, sacred centre of the famous ninth-century Loro Jonggrang temple complex at Prambanan, Central Java, is decorated with numerous iconic and narrative reliefs.¹ Starting from the eastern staircase and traversing the perambulatory in a clockwise direction, we find narrative reliefs of the *Rāmāyaṇa* on the balustrade wall on our left, and iconic reliefs of 24 seated male deities, each flanked by several attendants – collectively referred to in the accompanying iconographic plan (Figure 1) as ‘*lokapāla* with attendants’ – on our right, that is, on the temple body proper.

The objective of the present inquiry is to identify this set of 24 deities forming Śiva’s retinue – an unresolved issue in the art history of Central Java. Our findings have implications for the understanding of the iconographic master plan of Loro Jonggrang, and, in a wider sense, of developments in Indo-Javanese and Balinese iconography.

¹ The authors would like to thank Arlo Griffiths and Mark Long for their copious comments (the latter also for having provided them with his recent photos of panels D5 and D15, see Figures 8 and 10), and the two anonymous referees who reviewed the manuscript for their useful suggestions. The authors retain sole responsibility for any flaws to be found in this article. Andrea Acri wishes to thank the following institutions for their support during the period in which this article was researched, written and revised: the School of Culture, History and Language of the College of Asia and the Pacific, Australian National University; the Oxford Centre for Hindu Studies; and the Asia Research Institute, National University of Singapore.

ANDREA ACRI is postdoctoral fellow at the Asia Research Institute, National University of Singapore. His main academic interests include the Shaiva religion in India and Indonesia, and Old Javanese and Sanskrit literature. He is the author of ‘On birds, ascetics, and kings in Central Java: Rāmāyaṇa Kakawin, 24.95-126 and 25’, *Bijdragen tot de Taal-, Land- en Volkenkunde* 166, 2010, pp. 475-506. He edited (with Helen Creese and Arlo Griffiths) *From Laikā eastwards: The Rāmāyaṇa in the literature and visual arts of Indonesia*. Leiden: KITLV Press, 2011. Andrea Acri may be contacted at ariaa@nus.edu.sg.

ROY JORDAAN is a private scholar. He obtained his PhD in cultural anthropology from Leiden University. His publications include ‘Bĕlahan and the division of Airlangga’s realm’, *Bijdragen tot de Taal-, Land- en Volkenkunde* 163, 2007, pp. 326-55, and ‘Candi Badut and the trajectory of Hindu-Javanese temple architecture’, *Artibus Asiae* 71, 2011, pp. 55-74. Roy Jordaan may be contacted at rejordaan@hotmail.com.

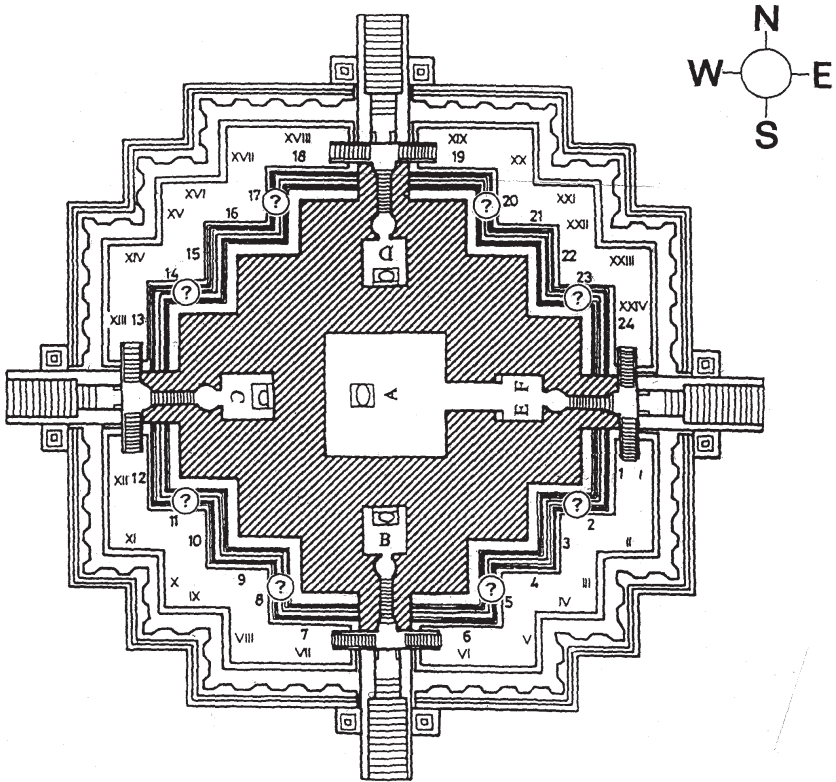

- A Śiva Mahādeva
- B Agastya
- C Gaṇeśa
- D Durgā
- E-F Nandīśvara-Mahākāla
- I-24 *lokapāla* with attendants
- I-XXIV Rāmāyaṇa reliefs



Figure 1. Iconographic plan of Caṅḍi Śiva, Loro Jonggrang (adapted from Jordaan 1996:6); the encircled question marks represent the eight unknown interstitial deities

Art-historical research thus far

First photographed by Kassian Cephas and discussed by Isaac Groneman (1893), who thought the 24 deities represented a mixed assembly of Bodhisattvas and Hindu deities, it was Martine Tonnet (2008) who recognized that 16

deities belonged to the category of Lokapālas or ‘world protectors’, that is, regents of the cardinal and intermediate directions. Most of these Lokapālas, on account of their seemingly similar features and attributes, were assumed to be represented twice. Tonnet proposed the following identifications:

East	Indra (2x)
Southeast	Agni (2x)
South	Yama (2x)
Southwest	Nairṛta and Sūrya
West	Varuna (2x)
Northwest	Vāyu (2x)
North	Kuvera and Soma
Northeast	Īśāna (2x)

Many years later, Van Lohuizen-de Leeuw (1955) reviewed the matter and agreed with all the identifications listed above, except for Nairṛta and Soma, for whom she proposed substituting Sūrya and Kuvera, respectively. She argued that the 16 deities are identical with a specific set of eight Lokapālas – whence their name Aṣṭadīkpālas, or eight (*aṣṭa*) deities, each of which guards (*pāla*) a particular point (*dīś*) or section of the world (see Figure 2).

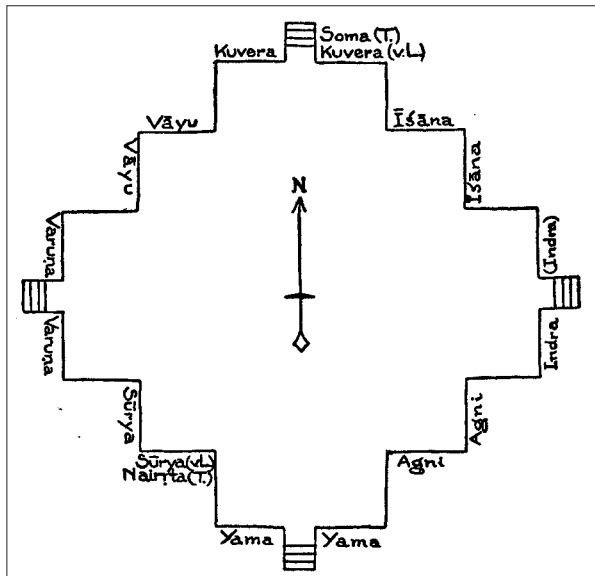

Figure 2. Plan of Tonnet's and Van Lohuizen-de Leeuw's identification of the Lokapālas of Caṇḍi Śiva (Source: Van Lohuizen-de Leeuw 1955:377)

According to Van Lohuizen-de Leeuw, the Aṣṭadikpālas depicted on the Śiva temple wall are in accordance with the Purāṇas, 'apart from the common substitution of Sūrya for Nairṛta'. She noted that her corrections 'improved the group as a whole for we have now a regular system in which each of the eight cardinal [and intermediate] points is represented by two panels depicting the same god' (1955:80). Even so, the ostensibly minor modification of substituting Sūrya for Nairṛta was disputed by Jordaan (1992), who argued that the Aṣṭadikpālas depicted on the temple are likely to comply with the standard list of the Purāṇas, in which Nairṛta (not Sūrya) is the guardian of the Southwest.²

Be that as it may, provided we accept the identification of the first series of reliefs as representing the Aṣṭadikpālas (henceforth referred to by the synonym 'Lokapālas'), the problem remaining is the identity of the eight gods on the panels flanking that first series, and the figures on the panels interposed between them. The figures belonging to the latter series are placed between the eight (four cardinal and four intermediate) directions of the compass, resulting in a regular distribution of three sets of eight deities on the temple wall. Tonnet proposed the following identifications for the eight deities on the interposed reliefs: (1) Bṛhaspati, or alternatively Bhatāra Guru (or a syncretic merging of the two) (relief 2); (2) Hanumān (relief 5); (3) Brahmaṇaspati (relief 8); (4) Sūrya (relief 11); (5) Kārttikeya (relief 14); (6) Kāma (relief 17) (7) Viśvakarman (relief 20); and (8) Nārada (relief 23). This yields the set of 16 deities in Figure 3.

The investigation continued

Considering the substantial advances in the study of ancient Javanese art, literature and religion since the time Tonnet and van Lohuizen-de Leeuw wrote on the issue,³ as well as the advances in studies of related cultural domains of

² So far this point of disagreement has received scant attention among professional archaeologists and art historians of Java. For instance, Maulana Ibrahim's (1996:13) identifications are the same as Tonnet's of 1908, with the pair of Nairṛta and Sūrya as joint Lokapālas of the Southwest, and Kuvera and Soma as the guardians of the North, whereas Cecilia Levin (1999:306) simply reproduces Van Lohuizen-de Leeuw's identifications of 1955, with Sūrya as the twice-represented Lokapāla of the Southwest. Moertjijpto and Prasetyo (1994) mention 'Niruti' as the guardian deity of the Southwest and Kuvera of the North, but without any arguments or references. Soekmono (1995:96) mentions the eight deities (Aṣṭadevatas or Lokapālas) encircling Śiva, together forming the Navasaṇas, without discussing them in relation to Caṇḍi Śiva. Above all, these examples serve to illustrate the slow progress in Indo-Javanese art history.

³ Śaiva religion and its foundational scriptures in both the Indian subcontinent and Java/Bali were still little known and studied then. Both these scholars relied upon such studies as Coleman (1832) and Wilkins (1913) which, although foundational, are now outdated – especially with respect to Śaiva traditions.

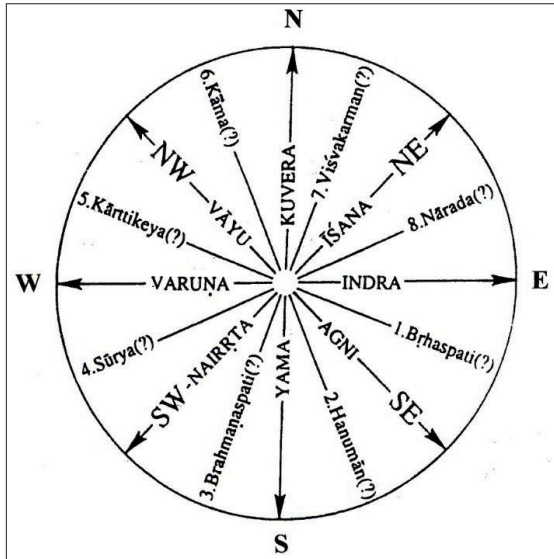

Figure 3. Circle diagram with the names of the Aṣṭadīpālas in capital letters with their direction, and Tonnet's tentative identifications of the other set of eight deities, whose names are followed by question marks as in Figure 1 (adapted from Jordaan 1996:101)

the Indian subcontinent, we propose an alternative hypothesis for the conceptual plan underlying the iconography of Caṇḍi Śiva – and its satellites Caṇḍi Viṣṇu and Caṇḍi Brahmā – of the Loro Jonggrang complex.

First, we reject van Lohuizen-de Leeuw's (in part also Tonnet's) opinion that the Lokapālas are represented twice. Besides the fact that we could find no plausible reason justifying the builders' choice to duplicate this series of deities,⁴ we found that not all the deities, or their attendants, display identical iconographic features.⁵ This was noted by Tonnet, who regarded the two Southwest panels as representing Nairṛta and Sūrya, and the two North panels as representing Kubera and Soma. However, if we accept Tonnet's identifications, the resulting scheme (including the deities placed between the intermediate directions) yields a 'random' series of unrelated deities whose grand total

⁴ We do not think symmetry is a convincing argument. One may argue that architectural reasons were involved: the temple's main axis being occupied by staircases and its secondary axis being corners, it is not possible for the Lokapālas to occupy their 'real' or proper positions. If so, however, one would expect the eight interstitial deities, representing the intermediate directions, to be duplicated as well – which is not the case. Further, as far as we know, no other temples in the Indonesian archipelago (and, possibly, the Indian subcontinent too) display pairs of Lokapālas.

⁵ A telling example is the different body shape of the deities forming the pair 'Kubera and Soma' (Tonnet) or '2x Kubera' (Van Lohuizen-de Leeuw): see below, Panels D18, D19.

amounts to 17 – a numerical as well as iconographic oddity that Tonnet herself was uneasy about and which was later dismissed by Van Lohuizen-de Leeuw.⁶

In Jordaan's introduction (1996) to a collection of Dutch articles on Prambanan, Van Lohuizen-de Leeuw is quoted as saying that she could accept some of Tonnet's identifications of the interposed deities, but not others. Regrettably, she does not mention the names of any of these deities, except Sūrya, for whom, as we have just noted, she claims a position among the Lokapālas at the expense of Nairṛta. Commenting on her statement about the remaining identifications, Jordaan observed that van Lohuizen-de Leeuw gives the impression that the interstitial deities were identifiable individually and do not necessarily constitute a well-defined group, such as the Lokapālas of the main directions. Jordaan (1996:103) argued for an approach from the latter premise:

It seems impossible to make progress by inductively trying to identify each of the deities individually. If one follows this procedure, one arrives at van Lohuizen-de Leeuw's position, namely that some of Tonnet's identifications are unacceptable, while others are more plausible. This would be a meaningless conclusion as long as it did not uncover the common theme or principle uniting the deities. It seems more logical to start from the premise that these eight figures were not grouped together randomly, but rather constitute a distinctive set, grouped together in this place for a specific reason.

In *The Hindu temple*, Stella Kramrisch refers to such accompanying deities in general terms only, namely as 'certain specific images of the lesser gods'. Kramrisch (1976, II: 304) has the following to say about the occupants of the interposed sections:

Apart from the main images, in their niches, and indispensable to all temples are the images of the Aṣṭadikpālas, the Guardians of the Eight points of space, each in its correct location. The multitude of divine figures stationed between these two kinds of essential images, each on a facet and having a console of its own, are Nāgas, Śārdūlas, Apsaras, Surasundarīs, Mithunas, etc. [...] and certain specific images of the lesser gods. Each such type of the 'surrounding divinities' is represented in many variations of posture and movement on the walls of the temple.

Note the wording 'certain specific images of the lesser gods', which seems to indicate that these gods were not selected at random, but for a particular reason. It seems to us that a convincing identification of these deities should

⁶ Van Lohuizen-de Leeuw 1955:380. The odd number is due to Tonnet's identification of the interstitial deity between Southwest and West as Sūrya, who is already represented in one of the two panels associated with the Southwest, thus resulting in his being represented twice.

be based not only on their intrinsic iconographic features (such as posture and attributes), but should also conform to some set of ‘lesser gods’ known from Old Javanese or Sanskrit textual sources or archaeological remains. It is therefore against the background of Śaiva views of the cosmos – of which the Hindu temple is ultimately a representation – and of the position of Lord Śiva, along with his retinue, within this conceptual framework that the iconography of Caṇḍi Śiva should be investigated.

Introducing Śiva’s retinue

Before reviewing in detail our predecessors’ identifications of the 24 relief panels of Caṇḍi Śiva, and then advancing our own, we discuss, from a textual and historical perspective, beliefs about Śiva’s retinue in India and ancient Java. These beliefs carry important implications for the present enquiry.

First is the concept of *āvaraṇa*, a series of deities encircling the main god that is made the object of ritual worship, meditative visualization (as in a *maṇḍala* or *yantra*), enshrinement or depiction in a building. Such a circle – or series of circles – of deities surrounding the paramount Lord Śiva has the function of protecting him and evoking the powers that are sought after, worshipped or visualized in a given context. Although *āvaraṇa* may be formed by independent deities, such as Rudras, all of them ultimately constitute aspects or manifestations of Śiva himself.

The series of deities in question are usually hierarchically and schematically arranged in inner and outer circles. The most common standard encountered in Sanskrit Śaiva scriptures preserved in South India is five, but this number is by no means fixed: for instance, descriptions of *āvaraṇa* ranging from one to six circles can be found.⁷ The Śaiva *āvaraṇa* may include, for example, the octads of Rudras known as Vidyēśvaras and Mūrtis; the Lokapālas (along with, or symbolized by, their weapons); the attendant deities known as Gaṇēśvaras; or the aspects/faces/limbs of Śiva known as Brahmamantras and Śivāṅgamantras.

It seems very likely that the concept of *āvaraṇa* deities was known in ancient Java and applied to the master plan and iconography of the Śiva temple of Loro Jonggrang, where the Lokapālas also serve as manifestations of the main god, Śiva. A first step towards the identification of the *āvaraṇa* of the Śiva temple is to investigate whether any series of guardians or attendants of the directions attested in the iconography of South Asian Śaiva temples or

⁷ Compare the discussion by Goodall et al. 2005:23–6; Brunner, Oberhammer and Padoux 2000:205. Note that the *Niśvāsataṭṭvasaṃhitā*, which is probably the earliest known Siddhāntatantra (probably fifth or sixth century AD), gives only three outer circuits, that is the Vidyēśvaras, the Lokapālas, and their weapons.

described in Śaiva scriptural literature, may have served as the prototype that inspired the Javanese architects. As for the latter source, it is probable that the early Śaiva Saiddhāntika corpus of Sanskrit scriptures from South Asia served as the prototype for the Old Javanese literature that constituted the doctrinal basis of the 'localized' variety of Śaivism flourishing in Java and Bali since the early centuries AD (see Acri 2006). We therefore make use of texts belonging to the corpus of Old Javanese-*cum*-Sanskrit texts known as Tuturs and Tattvas as important sources of information for our research.

Besides the well-known list of eight Lokapālas,⁸ two other sets of eight deities are widely mentioned in Śaiva Sanskrit texts, namely the Vidyeśvaras (or Vidyeśas, the 'Eight Lords of Knowledge') and the Mūrtyaṣṭakas (the 'Eight Forms' [of Śiva]; also Aṣṭamūrtis or Mūrtīśas).⁹ Considering that these deities are known to be part of Śiva's retinue, and are at the same time intimately connected with him either as 'aspects' or 'manifestations' (Liebert 1976:185, 336; Brunner, Oberhammer and Padoux 2000:156), they would not be out of place at the Śiva temple of Prambanan.

An argument in favour of the presence of the Vidyeśvaras at the temple is the fact that they are attested, albeit scantily, in Old Javanese Śaiva texts.¹⁰ For instance, in the *Dharma Pātañjala*¹¹ they are mentioned – as Vidyeśāna¹² – along with Brahmā, Viṣṇu and the Lokapālas.¹³ They further appear in the

⁸ The existence of a group of 16 Lokapālas is reported by Kirfel (1959:55), who notes their rare occurrence (*vereinzelt*). Regrettably, he does not give further details or references that would allow us to learn more about their identities.

⁹ The term is ambiguous, for it primarily designates the eight manifestations of Śiva in the world, namely the five elements, and the Moon, the Sun, and the Sacrificer (*yajamāna*) or, according to other traditions, mind (*manas*). These eight aspects are dominated by the respective Lords (Mūrtīśas), themselves constituting manifestations of Śiva, being Śarva, Paśupati, Ugra, Bhava, Īśvara, Mahādeva and Bhīma (Brunner, Oberhammer and Padoux 2000:156-7).

¹⁰ Although the dating of Old Javanese Śaiva texts – either argumentative 'Tattvas' or mystical and esoteric 'Tuturs' – remains problematic, the texts used in this article (see *Dharma Pātañjala*, *Vṛhaspatitattva*, *Tattvajñāna*, *Bhuvanakośa*, *Bhuvanasaṅkṣepa*) belong to the earliest stratum of the corpus, which reflects the doctrinal status quo of Saiddhāntika sources composed in the subcontinent between the fifth/sixth and eighth/ninth centuries (Acri 2006:126, 2011a:210-1, 226, 2011b:12-3). Even in the case that the Old Javanese sources merely preserved an archaic doctrinal status quo but were actually composed at a later time, they are unlikely, in our opinion, to postdate the eleventh/twelfth century.

¹¹ See *Dharma Pātañjala*, p. 282, line 10. The single West Javanese palm-leaf manuscript transmitting this text is remarkably old, bearing a colophon dated 1469 AD.

¹² See note 14.

¹³ The names of the Lokapālas are not singled out in the passage in question; but elsewhere in the same text (p. 278 lines 8-10) the following list is given: Brahmā, Viṣṇu, Indra, Yama, Baruṇa, Kuvera, Āgneya, Nairṛiti, Bāyabya and Aiśānya. Note that the last four deities of the series are to be identified with Agni, Nīrti, Vāyu and Īśāna, having been named after the directions they govern. In the relevant passage of the *Dharma Pātañjala* this series of ten deities underlies a scheme according to which the theophany of Śiva (Pātañjala) and his four brothers (Kuśika, Gārgya, Maitri, and Kuruṣya) is surrounded by the Lokapālas of the ten directions, following the order nadir, zenith, E, S, W, N, SE, SW, NW, NE.

Vṛhaspatitattva, which lists their names one by one.¹⁴

As to the other series, that of the Mūrtyaṣṭakas, these are only rarely mentioned in the extant Old Javanese literature. We know of only two sources referring to them, namely the *Bhuvanakośa* and the *Brahmāṇḍapurāṇa*. Verses 3.1-11 of the former text homologize this series of deities to ontological principles when detailing the process of reabsorption of the cosmos into Śiva, as follows: Śarva (earth), Bhava (water), Paśupati (fire), Īśāna (wind), Bhīma (ether), Mahādeva (*manas*), Ugra (*tanmātra*), Rudra (*tejas* = ahaṅkāra), Īśvara (*buddhi*), Brahmā (*avyakta*), Puruṣa (*caitanya*), Maheśvara (*kāraṇa*).¹⁵ The *Brahmāṇḍapurāṇa* (p. 56) mentions an incomplete, and slightly different, list of seven deities that are characterized as forms of Parameśvara (that is Śiva) – who is himself a son of Brahmā – as follows: Rudra, Bhava, Śarva, Īśa, Bhīma, Ugra, Mahādeva. Paśupati, the deity that would make the series an octad, is missing as the result of a textual corruption.

The above data, however, do not stand up to extant archaeological and textual iconographic evidence. Inspection of Rao's classic study *Elements of Hindu iconography* (1916) reveals that neither the Vidyeśvaras nor the Mūrtyaṣṭakas are considered to be depicted on Caṅḍi Śiva in view of striking iconographic incongruities. According to the descriptions found in Sanskrit textual sources, both the Vidyeśvaras and Mūrtyaṣṭakas are four-armed, while some are three-faced,¹⁶ contrary to the unidentified Prambanan deities who each have two arms and one face. Also relevant is Rao's (1916:404) remark that there are no sculptural representations of the Vidyeśvaras and Mūrtyaṣṭakas in any of the South Indian temples, and that he did not know of any found in a North Indian temple. This would make their presence in Java exceptional and, therefore, unlikely.

Another counter example is provided by the eight Bhairava gods or Aṣṭabhairavas, who in the Indian zodiac of the Śiva Rock Temple at Tiruchirappalli happen to occupy the positions of the intermediate directions (see Mollien 1853; Kirfel 1959:56). Apart from the fact that this series is mentioned nowhere in extant Old Javanese sources, what seems to argue against the identification of the Prambanan deities as being Aṣṭabhairavas, is that at Tiruchirappalli they are depicted as four-armed and that some of their attri-

¹⁴ See *Vṛhaspatitattva*, Old Javanese commentary to Sanskrit śloka 14, lines 19-26. The edited text as well as Zoetmulder's *Old Javanese-English dictionary* read *aṣṭavidyāsana*, translating it as 'the Eight Seats of Learning'; the alternative reading Vidyeśāna (as found also in *Dharma Pātañjala* 282.10) is discussed in Acri 2011b:63-4. For a hypothesis that the *Vṛhaspatitattva*'s description of the Vidyeśvaras and their cosmic role reflects views found in early Saiddhāntika sources from South Asia, see Acri 2011a.

¹⁵ See Ziesenis 1939:99-100.

¹⁶ This piece of information concurs with data drawn from recently edited Sanskrit Śaiva sources such as the twelfth-century *Pañcāvaraṇastava* by Aghoraśiva; see the useful table in Goodall et al. 2005:33-44.

butes are not found among the Prambanan deities. It is true that in Liebert's (1976:36) iconographic dictionary several varieties of Bhairavas are distinguished, but most of their attributes do not match the Prambanan deities either.

So far, our search for a prototypical group of deities common to both the ancient Indian and Javano-Balinese traditions has failed to produce a series that can be convincingly linked to those depicted on Caṇḍi Śiva. We therefore wonder whether a 'localized' series, that is, one attested only in the Javano-Balinese tradition, could offer a clue to get out of the present impasse.

An interesting clue is offered by van Lohuizen-de Leeuw herself in her article 'The Dikpālakas in ancient Java' (1955). In her discussion of the identification of the Lokapālas in the East Javanese temples of Jalatuṅḍa, Singhasari and Panataran, van Lohuizen-de Leeuw draws attention to a series of Śaiva deities commonly referred to in Bali as Navasaṅa (Sanskrit *nava* + Old/Modern Javanese *sania/sanga*, both meaning 'nine'). These deities – which are themselves manifestations of Śiva – are aptly named, since they rule or watch over the nine principal directions of the compass (that is, eight plus the centre). Van Lohuizen-de Leeuw notes striking correspondences between the attributes of the eight deities and those of the Lokapālas. The correspondences, drawn on the basis of the Balinese texts and visual documents used by van Lohuizen-de Leeuw, are as follows:¹⁷

East	Isuara	<i>bajra</i>	[thunderbolt]
Southeast	Mahesora	<i>dupa</i>	[burning incense/flames]
South	Brahma	<i>danda</i>	[rod]
Southwest	Rudra	<i>kadga</i>	[sword]
West	Mahadeva	<i>pasah</i>	[snare]
Northwest	Sangkara	<i>duaja</i>	[banner]
North	Visnu	<i>gada</i>	[mace]
Northeast	Sambu	<i>trisula</i>	[trident]
Nadir	Darma	<i>cakra</i>	[wheel]
Centre	Siva	<i>padma</i>	[lotus]
Zenith	Guru	<i>naraca</i>	[balance]

This series appears to be well known in Bali, where it still plays a role in many aspects of ritual and religious practice, art, and architecture.¹⁸

¹⁷ See Van Lohuizen-de Leeuw 1955:372-3, Chart VI (the original spelling of which has been reproduced here). In compiling the chart, Van Lohuizen-de Leeuw drew on Balinese drawings on pieces of cloth, reproduced and discussed in early twentieth-century contributions by Damsté, Goslings and Nieuwenkamp; and on drawings found in an Old Javanese manuscript from Bali published by Damsté. The variants in this list, for instance with respect to the deities' attributes, are reported below, in our chart. Compare also the chart in Tan 1967:445, summarizing data gathered by previous authors.

¹⁸ Compare the drawings of the Navasaṅas by contemporary Balinese artists such as I Ketut Bu-

As van Lohuizen-de Leeuw rightly observes, this series may represent a Javanized version of the manifestations of Śiva known in South Asian Sanskrit literature as the Mūrtyaṣṭakas.¹⁹ Although hinting at the possibility of the Navasaṅgas being represented at Panataran instead of the Lokapālas, van Lohuizen-de Leeuw (1955:376) was puzzled as to whether the one set preceded the other, or both were used simultaneously. She considered the possibility of a conflation between the two octads but did not investigate the matter further. In her view, the Navasaṅgas were introduced in Java in the mid-fourteenth century at the earliest, but they derived from an ancient Indian prototype.²⁰

An intriguing question is why the two series eventually came to share the same attributes. One possible answer is a merging of the two octads: a general one, formed by the mainstream 'Brahmanic' series of Lokapālas, and a specifically Śaiva one, formed by the Navasaṅgas. Van Lohuizen-de Leeuw herself (1955:381) hinted at this possibility by suggesting that the set of attributes of the Lokapālas was 'borrowed' by the Navasaṅgas.²¹ In her opinion, the Lokapālas were replaced by the Navasaṅgas, and the attributes of the former were conferred upon the latter. She concludes her article with an interesting remark: 'We should leave open the possibility that the Dikpālakas at Singhasari were already indicated by names of Śiva although retaining the attributes and *vāhanas* of the older group of Dikpālakas' (Van Lohuizen-de Leeuw 1955:383). Further:

diana and I Gusti Nyoman Mirdiana, reproduced in Stephen 2005:126, 128. According to Stephen (personal communication, October 2011), Mirdiana did not draw on textual sources but on a commonly known (oral) tradition concerning the iconography of the Navasaṅgas. As can be inferred from the drawings, the series of nine deities displays the same set of attributes, and is ordered according to the same spatial sequence, as the series described by Van Lohuizen-de Leeuw.

¹⁹ Besides consisting mainly of forms of Śiva, the two series have three deities in common, namely Paśupati, Īśvara and Mahādeva. The Mūrtyaṣṭakas also share five forms with the eleven manifestations of Śiva called Ekādaśarudras, who themselves share three aspects in common with the Navasaṅgas (see Van Lohuizen-de Leeuw 1955:382). A conscious attempt to associate the Navasaṅgas and the Mūrtyaṣṭakas by attributing to the former the rulership over the elements associated with the latter is found in a Sanskrit hymn from Bali (*Stuti and Stava*, 73), which correlates the Navasaṅgas with the eight elemental manifestations of Śiva, as follows: Rudra/earth, Īśvara/water, Śaṅkara/fire, Hara (=Viṣṇu)/wind, Īśāna/moon, Śiva/ether, Mahādeva/sun, Sureśvara (=Maheśvara)/*yajamāna*.

²⁰ See Van Lohuizen-de Leeuw 1955:381-2: 'Although it is clear now that the Navasaṅgas took over from the Aṣṭadikpālakas this does not imply that the group as such is much younger than the Aṣṭadikpālakas. Undoubtedly it goes back to a group which must have existed in India long before that.'

²¹ In particular, she notes the correspondence between the attribute of Viṣṇu appearing among the Navasaṅgas, namely the *gadā*, and of Kubera, but on the other hand remarks that 'most of the gods and their attributes are unrelated, such as Maheśvara and the flame, Brahmā and the *danḍa* or Śaṅkara and the *dhvaja*'. This led her to conclude that 'a set of new names for the Dikpālakas was introduced towards the end of the East Javanese period, but their attributes remained the same as those of the Aṣṭadikpālakas'. We find this line of reasoning unconvincing, especially with respect to the iconography of Caṅḍi Śiva. Note, for example, that both panels that are said to represent Vāyu do not provide that deity with a *dhvaja* but with incense on lotus.

It is possible that already in early times the Aṣṭadikpālakas were considered aspects of the great god Śiva. This would be entirely in line with the general Indian belief cherished also in Hindu Java, that all differentiations are but aspects of the One Deity, whether He be called Śiva, Viṣṇu or be indicated by any other name. This idea seems to be corroborated by the fact that a considerable number of guardians at Lara Jonggrang have differing earrings in their left and right ears which is a peculiarity of Śiva. If the idea that the Aṣṭadikpālakas were aspects of the great god Śiva existed already in the Central Javanese period, then it is clear that the ground was already prepared at a very early date for the eventual change-over from Aṣṭadikpālakas to Navasanga (p. 384).

In an attempt to find a solution to this problem, let us carry Van Lohuizen-de Leeuw's consideration one step further and see whether evidence of an identification between the Lokapālas and the Navasaṅas can be found in the Central Javanese period and in the iconography of Caṅḍi Śiva. We begin by presenting data drawn from Old Javanese Śaiva texts that were not available to Van Lohuizen-de Leeuw,²² to see whether they might help us identify the 24 deities carved on the temple wall.²³

First, while the extant evidence for the term *navasāna* is of relatively recent date,²⁴ the same series of deities is attested in other – arguably earlier, that is pre-Majapahit – Old Javanese texts. These texts either pass over in silence the collective designation of the deities, or refer to them as Digbandhas ('those fixing the quarters of space') or Lokanāthas ('Lords of the world'), both being near synonyms of Lokapālas. In order to avoid possible anachronism, from now on we shall refer to this series of deities as (Śaiva) Digbandhas rather than Navasaṅas.

Second, a tendency to identify the Lokapālas with forms or manifestations of Śiva can already be observed in several early Old Javanese Śaiva texts.²⁵ For instance, as noted by Ziesenis (1939:109-10), the *Bhuvanakośa* describes the octad of Lokapālas in terms that apparently identify them as manifestations of Śiva himself.²⁶ Similarly, the *Sūrya Sevana*, describing the daily Śaiva worship of

²² Other sources than those mentioned here can be found in Damais 1969. Our focus is on texts that are arguably early, texts that could have been known, in one form or another, to the builders of the Loro Jonggrang temple complex.

²³ Symbols strongly reminiscent of the attributes of the Digbandhas/Navasaṅas have been found on a stone unearthed in 1985 from the Opak River, which might have been transported by the river from its original location in Caṅḍi Loro Jonggrang and which, in any event, arguably dates back to the Central Javanese period (Setianingsih 1998).

²⁴ Zoetmulder's *Old Javanese-Sanskrit dictionary* only lists rare occurrences of the term in such demonstrably late texts (about fifteenth century) as the *Koravāśrama*, the *Navaruci*, and the *Tantri Kēḍiri*. On the other hand, the term is frequently attested in Modern Javanese and Balinese sources.

²⁵ For the dating of these texts, see note 10.

²⁶ Note that the series has Nirṛti instead of Sūrya, and Soma instead of Kubera.

the Balinese *pědanda* as reconstructed by C. Hooykaas (1966), lists various series of deities, both male and female, constituting Śiva's retinue and, at the same time, aspects of him. Section Nf (Hooykaas 1966:70) assigns each Digbandha a gesture (*mudrā*) and places him in a leaf of an eightfold lotus, with which a grapheme of the Sanskrit syllabary is associated. When dealing with the visualization of Śiva's nine female Powers (*navaśakti*), which are also the Digbandhas' consorts, section Ng (Hooykaas 1966:72) lists the eight Lokapālas.²⁷ The two series, the Lokapālas and Digbandhas, therefore appear to be closely related.

Another rich source of data on manifestations of Śiva and his retinue is the large collection of Sanskrit hymns from Balinese manuscripts edited by Goudriaan and Hooykaas (1971) under the title *Stuti and Stava*. First, note that the 'standard' list of Lokapālas does not prominently figure in that corpus of texts. In hymns 802, 824, 935, and a few others, we find mention only of the quartet of Lokapālas of the cardinal directions, namely Indra (E), Yama (S), Varuṇa (W) and Kubera (N). An exception is Stuti 40, *Ākāśastava*, which mentions the eight deities (with Sūrya instead of Nairṛti) as aspects of Śiva. Much more numerous are the hymns mentioning only the Digbandhas.²⁸ Most of these correlate each deity with, for example, a direction of the compass, a colour, an attribute or weapon (*astra*), or a grapheme of the Sanskrit syllabary.

A summary of the data drawn from both textual and visual documents is presented in Table 1.

Direction	Deity	Attribute			
		Sūrya Sevana (<i>mudrā</i>)	Stuti 94, 772 (<i>astra</i>)	Stuti 363, 703, 706 (<i>astra</i>)	Van Lohuizen-de Leeuw, Chart VI + notes
E	Īśvara ¹	<i>bajra</i>	<i>vajra</i>	<i>bajra</i>	<i>bajra/ghanṭā</i>
SE	Maheśvara	<i>saṅkha</i>	<i>dhūpa</i>	<i>dhūpa</i>	<i>dhūpa</i>
S	Brahmā	<i>daṇḍa</i>	<i>daṇḍa</i>	<i>daṇḍa</i>	<i>daṇḍa</i>
SW	Rudra	<i>khaḍga</i>	<i>khaḍga</i>	<i>mokṣala</i> ²	<i>khaḍga/mokṣala</i>
W	Mahādeva	<i>pāśa</i>	<i>pāśa</i>	<i>pāśa</i>	<i>pāśa/nāgapāśa</i>
NW	Śaṅkara	<i>dhvaja</i>	<i>dhvaja</i> ³ / <i>aṅkuśa</i>	<i>aṅkuśa</i>	<i>dhvaja/aṅkuśa</i>
N	Viṣṇu	<i>cakra</i>	<i>gadā</i> ⁴ / <i>cakra</i>	<i>cakra</i>	<i>gadā/cakra</i>
NE	Śambhu	<i>triśūla</i>	<i>triśūla/aṅkuśa</i>	<i>triśūla</i>	<i>triśūla</i>
Centre	Śiva ⁵		<i>padma</i>	<i>padma</i>	<i>padma</i>

1 Stuti 772 only has Guru/Vāsudeva.

2 Stuti 363 has *padma*. The term *mokṣala* is apparently a hybrid form derived from the Sanskrit *musala/muṣala* ('club, mace').

3 In Stuti 772, Ms. PvtG.

4 In Stuti 772, Ms. PvtG.

5 Sadāśiva in Stuti 94; Mahābhairava in Stuti 772.

27 As above, note 26.

28 Such as, just to list a few: 73, 94, 103, 145, 157, 363, 703, 706, 772.

A hymn mentioning the Śaiva Digbandhas together with the Lokapālas – albeit only four of them – is Stuti 145. But our most comprehensive source of information is the impressive Stuti 751, titled *Śivastava* or *Śivasamūha*, which, while praising Śiva as the paramount Lord, characterizes his body as made up of various elements of the Śaiva cosmos, such as the 9 planets, the 31 *tattvas* and the 38 *kalās*, as well as deities that constitute his manifestations. In verses 4-9, Stuti 751 equates Śiva with three of the Digbandhas, namely Brahmā, Viṣṇu, and Mahādeva, and then with the Lokapālas, namely Indra, Varuṇa, Yama, Kubera, Sūrya, Agni, Vāyu, and Īśāna. The hymn continues (verses 9cd-10ab) by listing another series of eight manifestations, namely Satya, Dharma, Śiva, Kāla, Mṛtyu, Krodha, Viśva, Kāma,²⁹ and Hari (a name for Viṣṇu); although this is not expressly mentioned in the text, each deity seems to be correlated with a direction of the compass.

An analogous list of eight additional deities, each explicitly correlated with a direction, is found in the Batuan plates³⁰ dated 944 Śaka (no. 352, plate 6 verso, lines 1-2, see Goris 1954:100): Satya (East), Dharma (South), Kāla (West), Mṛtyu (North), Krodha (Southeast), Kāma (Southwest), Īśvara³¹ (Northwest), Hari (Northeast). Another such list is found in the undated, but probably early tenth century AD, Wukajana copperplate inscription (plate 1 verso, line 3, see Van Naerssen 1937:445). Having invoked all deities residing in the eight main directions (not naming them but only their respective directions), the text lists Satya, Dharma, Kāla, Mṛtyu, Krodha, Viśva, Kāma, and Viṣṇu; then the gods of the centre, nadir, and zenith. This series corresponds to a three-dimensional cosmogram encompassing all the cardinal and intermediate directions of the compass (8 + 8 + 3). The unnamed eight deities of the main cardinal points are very likely the Śaiva Digbandhas. This possibility is suggested by the occurrence of a series of 8 + 8 + 3 deities in the Sanskrit/Old Javanese Śaiva Tukur *Bhuvanasankṣepa*. Ślokas 11-13 detail the consecration of the eight Digbandhas in the directions of the compass, plus Sadāśiva in the centre, Paramaśiva in the zenith, and Hara in the nadir. Stanza 14 specifies that each of the deities of the additional octad (as in Stuti 751 and the Sangsang plate, save for one variant) should be placed between the eight main directions. The ensuing stanzas, up to 24, link each of the above deities to specific colours and *bījamantras*.³² The distribution of the deities in the

²⁹ The editors read *viśvakarmā*, but the expression is evidently corrupt as we expect a list of eight deities instead of seven; the reading should be emended to *viśvakāmā* (a Sanskrit *dvandva* compound, meaning ‘Viśva and Kāma’; compare the parallel lists described below).

³⁰ We thank Arlo Griffiths for having pointed out this occurrence to us.

³¹ Given the discrepancy with the series attested in the other sources, we suspect that *īśvara* could be either a misreading for *viśva* by Goris, or a mistake made by the engraver of the inscription.

³² Ziesenis (1939:183) points out that the same list of eight interstitial deities occurs elsewhere in the *Bhuvanasankṣepa*, where the text describes a (rather idiosyncratic) ‘vertical’ involution pro-

cardinal and intermediate points of the compass, and their Sanskrit syllables, are shown in Figure 4.

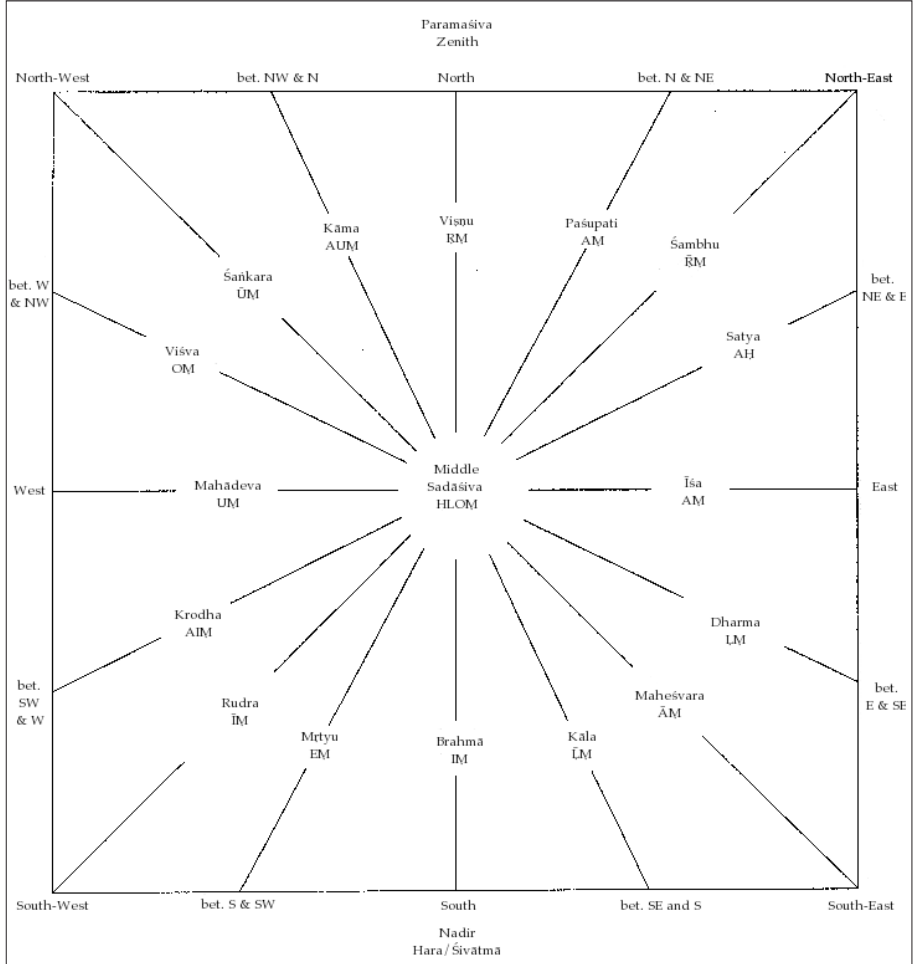

Figure 4. The directions and their regents according to the *Bhuvanasaṅkṣepa* (adapted from Lokesh Chandra 1997:116)

The cosmogram reproduced here may represent a uniquely Javano-Balinese tradition, for no exact counterpart has yet been found elsewhere – although nearly all the gods and manifestations of Śiva appearing here are known in

cess through the 24 ontological levels, hierarchically ordered from the lowest to the highest, of Earth, Water, Fire, Wind, Ether, Kāma, Viśva, Krodha, Mṛtyu, Kāla, Dharma, Satya, Śaṅkara, Paśupati, Brahmā, Viśṇu, Īśvara, Rudra, Devaguru, Puruṣa, Śiva, Nirvāṇa, Anāmaka, Sūkṣmatva (= Śaṅkara).

the Indian subcontinent. Whatever the case may be, it seems reasonable to ask whether this representation of the Śaiva cosmos could have constituted the prototype for the iconographic master plan underlying Caṇḍi Śiva, and, from a wider perspective, of the Loro Jonggrang temple complex. Could the series of 16 deities of the points of the compass listed by the *Bhuvanasaṅkṣepa* and other Old Javanese texts match the 16 deities depicted on the panels of the temple? Additionally, are the three extra directions of nadir, zenith, and centre also represented at Loro Jonggrang? We think the answer to these questions is affirmative, and the next part of our enquiry is devoted to them.

A problem, however, arises with respect to the total number of deities depicted on the Caṇḍi Śiva panels, which is 24. Since we dismissed the possibility of the Lokapālas being represented twice, we have to find a way to reconcile the cosmogram (see Figure 4), including the 16 Śaiva Digbandhas, with the one admitting eight Lokapālas. The solution was already suggested by Van Lohuizen-de Leeuw, who hinted at the possibility that attempts at merging the two traditions are traceable in early Javanese iconography. We will therefore check against the available archaeological and visual evidence the hypotheses (1) that the builders of Caṇḍi Śiva intended to represent the eight standard Lokapālas, the eight main Śaiva Digbandhas, and one more series of eight interstitial Digbandhas; and (2) that they regarded these deities to be both ‘guardians’ and manifestations of the paramount form of Śiva – enshrined in the centre of the main temple – they encircle. We suggest that the representations of the deities should be viewed within the wider context of Loro Jonggrang, comprising Caṇḍi Śiva and its satellites Caṇḍi Viṣṇu and Caṇḍi Brahmā, lying respectively to the north and south of the main temple (see Figure 5).

Before embarking on our identification, note that the conceptual plan for the Caṇḍi Śiva panels appears to have been developed in Java according to a well-established Indic tradition. A clue in support of this view may be found in Pott’s seminal study *Yoga and Yantra* (1966, Dutch edition 1946). Elaborating on related Indo-Javanese and Tibetan systems of deities, Pott (1966:136) advances the view that the system of the Navasānas was a simplification and contraction of the more complex pantheon of the Śaivasiddhānta. Describing the dynamic aspect – underlying the principle of metaphoric ‘substitution’ – of ensembles of 3 × 8 guardian deities used in *maṇḍalas*, temples, and meditative visualization, Pott (1966:100) notes:

The eight-petalled lotus is directly related to the system of eight Lokapālas (guardians of the cardinal points) and to other well-known groups of eight such as that of the Bhairavas. They are the eight aspects, distributed by cardinal points, of one centrally positioned figure which is seated in the heart of the lotus. This principal figure, however, forms part of a no less important group of three deities, with the consequence that there may come about a contamination of both groups [...]

We believe that analogous considerations can be applied to the three sets of eight deities represented on Caṇḍi Śiva, resulting in a grand total of 24. Still, we cannot exclude the possibility that the pairs formed by Lokapālas and the (main) Digbandhas once constituted a unified series of eight, to be added to the other series of eight interstitial deities. The finding of consecration deposit boxes having either 25 (24 + centre), 17 (16 + centre) or 9 (8 + centre) compartments in South and Southeast Asian temples would seem to confirm the existence of both configurations.³³ The 19 inscribed gold leaves found under Caṇḍi B of Loro Jonggrang apparently presume three sets of deities, namely the eight Lokapālas, four Nāgas, the four qualities of intellect (*buddhi*) making up Śiva's throne, and three other deities probably representing the nadir, zenith and centre.³⁴ It is conceivable that in the minds of the planners of Loro Jonggrang such series of deities were associated with Sanskrit syllables, in their turn visualized on lotus petals, as is also suggested by the fact that gold-leaf lotus flowers, letters of the Sanskrit syllabary, and the name (of the Lokapāla) 'Baruṇa' inscribed on gold leaves were found in the consecration deposit boxes buried under Caṇḍi Śiva.³⁵ A similar association of syllables, lotuses and attributes of (Śaiva) deities is depicted on an engraved stone (BG 748) found in the Opak River, not far from Prambanan (see Setianingsih 1998:18); symbols reminiscent of the attributes of the Digbandhas/Navasaṇas are represented, in a diagram displaying lotus petals and lotus flowers, on another stone (BG 1521) from the same site.³⁶

³³ See Ślaçzka 2007:248-9. Soekmono (1995:15) mentions a box of nine compartments made of nine precious stones (*navaratna*), corresponding to the Navasaṇa deities.

³⁴ See Maulana Ibrahim 1996:56, BPPP Yogyakarta 2007:129-34. The names inscribed on the 19 leaves, as interpreted by Degroot, Griffiths and Baskoro Tjahjono (forthcoming), are: [Lokapālas:] Indra (E), Agni (SE), Yama (S), Riniti (a mistake for Niriti = Nirrti, SO), Baruṇa (O), Vāyu (NO), Soma (N), Isāna (NE); [Nāgas:] Ananta, Bāsuki, Kapila, Takṣaka; [four qualities of *buddhi*:] Dharma, Jñāna, Vairāgya, Aisvarya; [zenith?] Dhasama (reading not certain); [nadir?] Brahmā; [centre?] Om Paścimagātrāya Namaḥ.

³⁵ See Ślaçzka 2007:250. Note that the compartments of a large number of deposit boxes from Javanese temples are shaped like lotus petals (see Soekmono 1995:11). On p. 177, Ślaçzka notes that Śaiva Sanskrit texts usually assign syllables, such as the 16 vowels, and deities, such as the Viḍyeśvaras, to the compartments of deposit boxes. See also Long's hypothesis (2009:111-24) concerning the correspondence between the 49 *aḥṣaras* of the Sanskrit syllabary and architectural elements of the eighth-century Buddhist Caṇḍi Mendut.

³⁶ See Setianingsih 1998:19. Compare with the attributes depicted in an eight-petalled lotus on a keystone from the ceiling of fourteenth-century Candi Ngrimbi in East Java (Pott 1966:133 and plate XVa). This stone is reminiscent of the vault stone of the Central Javanese (Śaiva) Caṇḍi Merak which, even though not depicting any attributes, seemingly conceives the temple as an eight-petalled lotus enshrining the central deity. Another interesting stone is the one found in Caṇḍi Sumberjati (thirteenth century), shaped like a circular 16-petalled lotus. It depicts the deities of the eight main directions, each four-armed and carrying a Śaiva rosary (*aḥṣamālā*) as well as the respective attribute of the Navasaṇa series (see Crucq 1936).

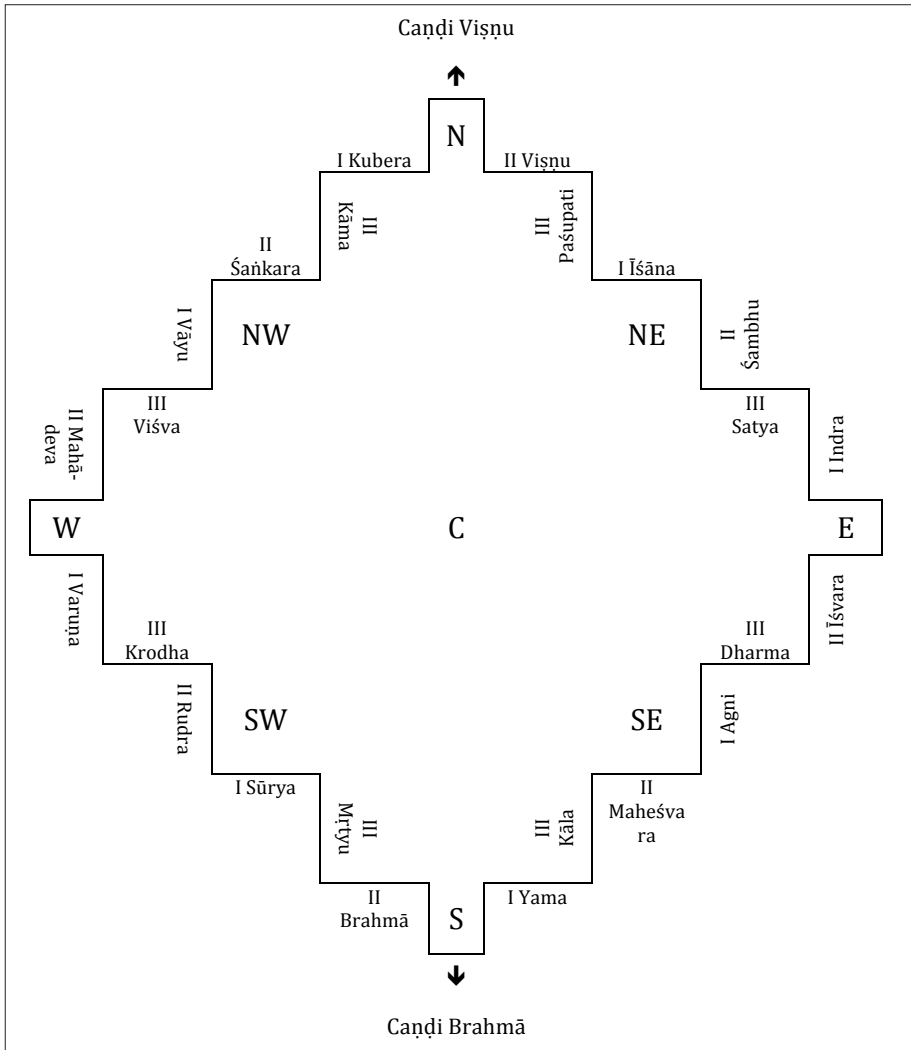

Figure 5. Plan of Caṇḍi Śiva with identifications of the 24 deities (comprising three series of eight)

New identifications

Before examining the identifications advanced by our predecessors and proposing our own, a few remarks are in order about the position and present condition of the reliefs so as to help the reader understand why the deities are so difficult to identify.

Relying on the reports of early European visitors and the old photographs of the Śiva temple by Kassian Cephas, dating from the 1890s, it may reasonably be assumed that the reliefs in question are still in their original positions. The iconographic information pertaining to the individual Lokapālas/Digbandhas and the eight interstitial deities is distributed over three interconnected panels: a slightly protruding and more or less square section in high relief being flanked by two rectangular sections in low relief. Whereas the image of the main deity is found in the middle section, his attendants or servants are depicted in the two side panels.³⁷ Regrettably, the figures in high relief are all damaged. In some cases, the damage is so serious as to obliterate the deity's main attributes. This is a serious problem given the paucity of other iconographic data. For instance, none of the main deities is escorted or represented by its mount (*vāhana*), which normally constitutes a fairly reliable mark for identification. More often than not, the identificatory value of other iconographic clues is limited because of their general or non-specific character. A sword or a bow and arrow, for instance, can be carried by a multitude of deities. The same considerations apply to the attendants in the flanking low reliefs. We therefore rely very little on the iconographic clues in these flanking panels.

Series I (Lokapālas) and II (Śaiva Digbandhas/Navasāinas)

It is our view that the pairs of deities represented as corresponding to the eight main directions of the compass – in spite of the fact that they mostly bear the same attributes – should be regarded as separate divine figures. The first series of eight represent the Lokapālas and the second the Śaiva Digbandhas. Yet the two series are clearly related, for they all represent aspects or manifestations of Śiva. As to the Lokapālas, some of them carry different attributes from the standard ones commonly found in 'classical' iconographic descriptions and representations from the Indian subcontinent (see Table 2).³⁸ Yet it is possible that the specific iconographic traditions that were considered normative by the Javanese artists have not survived in the subcontinent – a supposition that might be confirmed through further investigation of the surviving Sanskrit sources of Śaiva persuasion dealing with matters of iconography.³⁹

³⁷ As Krom observed long ago, 'the servants, usually three seated on either side [of the main deity], look significantly different from each other; apparently, it was endeavoured to have each of the main figures escorted by his proper followers' (1923:466).

³⁸ The standard attributes are those listed in Wessels-Mevissen 2001:1. Although the table in question is only a very general overview, it is useful for comparative purposes insofar as it provides a picture of the attributes that recurring the most. After a slash we have added and annotated any peculiar (non-standard) attributes that do have a counterpart in Caṇḍi Śiva (most of which are described in the *Matsyapurāṇa* and *Viṣṇudharmottarapurāṇa*). For a more detailed treatment of the attributes and iconography of the individual Lokapālas, see the tables in Wessels-Mevissen 2001.

³⁹ Note that Mevissen (2009:396, 399) refers to the period between the seventh and eighth centuries as the formative stage of the Aṣṭadīkpa scheme.

Table 2: Attributes of the Lokapālas (Series I) and Digbandhas (Series II) of Caṇḍi Śiva, compared with the standard attributes of the Lokapālas in South Asia (as listed in Wessels-Mevissen 2001:1)

Direction	Lokapāla	Caṇḍi Śiva (Series I)	Caṇḍi Śiva (Series II)	Indian subcontinent
E	Indra	thunderbolt (<i>vajra</i>) on top of a lotus	damaged	thunderbolt /water lily (<i>utpala</i>) ¹ /lotus (<i>padma</i>) ²
SE	Agni	incense (<i>dhūpa</i>)/lance with 7 flames	blue lotus	rosary (<i>akṣamālā</i>), water jar (<i>kamaṇḍalu</i>)/spear (<i>śakti</i>) ³ / flame (<i>jvalā</i>) ⁴
S	Yama	rod (<i>daṇḍa</i>)	rod	rod
SW	Nairṛti/Sūrya	jewel or flaming object (?) on lotus bud	jewel or flaming object (?) on open lotus	sword (<i>khadga</i>)
W	Varuṇa	serpent-snare (<i>nāgapāśa</i>)	serpent-snare	snare (<i>pāśa</i>)/serpent-snare
NW	Vāyu	censer (with 3 flames)/ hook (<i>aṅkuśa</i>) ?	censer (with 3 flames)/ hook ?	standard (<i>dhvaja</i>), billow- ing cloth/hook ⁵ /circle of air (<i>vāyumaṇḍala</i>) ⁶
N	Kubera	winged conch-shell (?)	jewel on lotus/fruit/bud (?)	club (<i>gadā</i>)/conch (<i>śaikha</i>) ⁷ / lotus bud, cup, purse or fruit ⁸
NE	Īśāna	trident (<i>trisūla</i>), skull (<i>kapāla</i>)	trident, skull	trident

1 See Wessels-Mevissen 2001:15 (table X), on the basis of *Matsyapurāṇa* 260.65-261.23.

2 See Wessels-Mevissen 2001:15 (table X), on the basis of *Viṣṇudharmottarapurāṇa* 2.104.42b-50a.

3 See Wessels-Mevissen 2001:15 (table X), on the basis of *Matsyapurāṇa* 148.81 and following.

4 See Wessels-Mevissen 2001:15 (table X), on the basis of *Viṣṇudharmottarapurāṇa* 3.50 and following.

5 See Wessels-Mevissen 2001:15 (table X), on the basis of *Matsyapurāṇa* 148.81 and following; compare also Wessels-Mevissen 2001:103, describing representations of a goad as an attribute of Vāyu found in Orissan temple art (at Gallāvalli and Gaṇeśvarpur).

6 See Wessels-Mevissen 2001:15 (table X), on the basis of *Viṣṇudharmottarapurāṇa* 2.104.42b-50a.

7 See Wessels-Mevissen 2001:16 (table XI), on the basis of *Hayaśiṅgasaṅgāra* 1.28 (probably 800 AD).

8 See Wessels-Mevissen 2001:104 (table XX), describing a 'Northern' type of Kubera holding such objects in various combinations, as opposed to a 'Southern' type holding a *gadā* only.

We start from the East and discuss the successive reliefs, proceeding in a clockwise direction.

1. *East* (Groneman 1893:20, 23, panels D1 and D24, plates XXXV and LVIII).

Tonnet (1908:146) rightly identifies the deity of the panel to the left of the staircase (D1/XXXV) as Indra. In his left hand he holds the stem of a lotus (*utpala*) that supports his characteristic attribute: the thunderbolt (*vajra*).⁴⁰ He is flanked

⁴⁰ Interestingly, this particular detail has a parallel in Ellora, India, on a Vajrapāṇi sculpture, illustrated in Malandra 1993, fig. 181. (We thank one of the anonymous reviewers of this article for pointing out this parallel.)

on the right by three female figures – arguably *apsarases*, who in Sanskrit and Old Javanese literature⁴¹ are commonly associated with Indra. The figures on his left appear to be *gandharvas*, who abide together with the *apsarases* in Indra's heaven. The corresponding panel on the other side of the entrance (D24/LVIII) is badly damaged, so it is not possible to discern the attribute of the main deity. The sitting posture of the three male figures to the left of the main deity is unusual in that the left foot of the first two figures is placed below the thigh of the next figure. The figure on the far right holds an *utpala*.

Tonnet does not justify her identification of the damaged panel D24 as depicting Indra, whereas Van Lohuizen-de Leeuw (1955:378) reasons that 'seeing that Yama, Varuṇa and Kubera were all three represented twice it seems permissible to assume that the damaged panel also represented Indra'. We note that all six minor figures of this panel seem to be male. Not every one of their attributes is clear, but we can discern a lotus flower, a piece of cloth, and a fruit.

The Digbandha of the East is Īśvara. On account of the severe damage of the main figure's attribute and the general nature of the attributes carried by his attendants, we are unable to complete the identification.

2. *Southeast* (Groneman 1893:20, panels D3 and D4, plates XXXVII and XXXVIII).

Tonnet (1908:138-9) regards the South-facing relief (D4/XXXVIII) as representing Agni on account of the lance with seven flames (*saptajihvā*) he carries. Van Lohuizen-de Leeuw concurs with this identification, but sees it a *dhūpa* (incense) with seven flames. However this may be, we agree that the main deity of the panel is Agni.

Both Tonnet and Van Lohuizen-de Leeuw regard the East-facing relief (D3/XXXVII) as representing a second form of Agni – *abjahasta*, 'he who carries a lotus' – for this is the attribute displayed by the deity of the panel.⁴² The Digbandha of the Southeast is Maheśvara. Because of the lack of specific iconographic correspondences between this figure and other representations of Maheśvara from South Asia, our identification must remain tentative.⁴³

3. *South* (Groneman 1893:20, panels D 6 and D7, plates XL and XLI).

According to Tonnet (1908:133), in panel D7 (plate XLI) Yama, identifiable by the rod depicted to his left (as well as his characteristic moustache, we might

⁴¹ See, for instance, *Arjunavivāha* 1.6-9 (early eleventh century).

⁴² A close inspection of the damaged relief, however, leads us to suspect that another item might originally have been depicted on top of the lotus.

⁴³ On the other hand, note that the standard attributes characterizing the iconography of Agni in the Indian subcontinent, that is the rosary (*akṣamālā*) and the water jar (see Wessels-Mevissen 2001:97), are absent in both panels.

add), is depicted as Kāla. Tonnet regards the leftmost attendant to be Citragupta, Yama's bookkeeper, allegedly with a calendar, which we cannot see. He carries a sword, like the first attendant to the left of the main figure (on a lotus). In panel D6 (plate XL) Tonnet recognizes Yama as Dharmarāja. We cannot see a snare on the lotus allegedly carried by Yama; the attribute looks more like a rod, similar to the one depicted in the panel to the left of the staircase. Van Lohuizen-de Leeuw concurs with the identification of both figures as Yama on account of the attributes they carry.

The Digbandha of the South is Brahmā. The rod (*daṇḍa*) is listed as an attribute of Brahmā by Liebert (1976:46);⁴⁴ Monier-Williams' *Sanskrit-English dictionary* glosses *brahmadanḍa* as 'Brahmā's staff', 'name of a mythical weapon', and 'name of Śiva'; the word is also used as an epithet of Lokeśvara, 'the Lord of the world' (Liebert 1976:47), which in turn may refer to Brahmā as well as to the Buddha Avalokiteśvara.

Note moreover that a position in the South would be appropriate for a figure representing Brahmā, given that it would face the auxiliary temple dedicated to the same deity on the South side of the Śiva temple. We encounter a similar situation on the North side of the Śiva temple, where the figure we believe depicts Viṣṇu would likewise face the auxiliary temple dedicated to Viṣṇu on the North side of the Śiva temple.

4. *Southwest* (Groneman 1893:21, panels D9 and D10, plates XLIII and XLIV). Tonnet identifies the deity in the South-facing panel (D9, and our Figure 6) as Nairṛta, and the one in the West-facing panel (D10, and our Figure 7) as Sūrya. Van Lohuizen-de Leeuw contests the former identification and proposes that both panels depict Sūrya. None of the deities in question carries Nairṛta's usual attribute, namely a sword (*khadga*), but instead a lotus topped with an object that could represent a jewel or the chatoyant sunstone (*sūryakānta*). Whereas Tonnet sees the frown of the West-facing deity as an aesthetic representation of a third eye (allegedly because the Prambanan sculptors objected to physical 'absurdities', Van Lohuizen-de Leeuw sees the frown or scowl as a common indication of an angry (*krodha*) form of this deity. As far as his counterpart in the South-facing panel is concerned, van Lohuizen-de Leeuw claims that this deity and his attendants had a more pronounced angry look than the West-facing deity. Noting that in Bali Sūrya is equated with the demonic form of Śiva known as Kāla, she adds that 'as Sūrya as well as Nairṛta occupy the inauspicious region of the Southwest, they would naturally show a *krodha* appearance' (Van Lohuizen-de Leeuw 1955:380).

Jordaan (1992), however, disagrees with Van Lohuizen-de Leeuw's identification of the South-facing panel as Sūrya. Along with Tonnet, who calls it the

⁴⁴ Compare *Pañcāvarāṇastava* 83, attributing a *daṇḍa* to the form of Brahmā that is intended to be the Lokapāla of the zenith (see Goodall et al. 2005:38, 88).

most mysterious of all the iconic reliefs, he discerns a number of notable differences between the West- and South-facing reliefs, for example in body shape and posture, crown, ear ornament, direction of glance, and waist band. In fact, the scowl is one of the few distinctive elements that the two reliefs of the Southwest have in common. Jordaan feels that the earlier identification of both figures as Nairṛta – Genius of death and dissolution – was prematurely abandoned.⁴⁵ Relying on Teeuw and Robson (1981:25), Jordaan notes that in Old Javanese literature ‘the direction of Nirṛti’ is a common term for Southwest. Indeed, Krom (1923:I 477), referring to some inscribed gold leaves found among the contents of the deposit box (*pripih*) placed underneath the pedestal of Śiva Mahādeva in the Śiva temple, mentions a small silver plate with the inscription ‘Niriti’ that was later retrieved from underneath the rubble in the northeastern corner of the temple. Furthermore, ‘Riniti’ (a mistake for Niriti, or Nirṛti) was one of the 19 names inscribed on small plates in the foundation deposit box of Caṇḍi B.⁴⁶ Occupying an inauspicious region associated with destruction and death, Nairṛta is described by de Mallmann (1963:130) as ‘très sombre, son aspect est celui du noir de fumée’. The serious facial damage of the deity makes it impossible to say if he did not once display ‘a gaping mouth, exposing teeth and side tusks’, as is stipulated for Nairṛta in some iconographic manuals (see, for example, Rao 1916:528). Indeed, the terrifying appearance may have caused a villager to inflict the damage, as happened with demonic Camuṇḍī and Heruka statues in East Java and Sumatra respectively (see Reichle 2007:161, and references to earlier literature on p. 247).

It is relevant to note that the demonic and frightful countenance of the deity represented on the panel is in harmony with the character of Rudra, the Digbandha of the Southwest. Insofar as he is an angry and demonic form of Śiva, Rudra may be regarded as an alter ego of Kāla who, as pointed out by Van Lohuizen-de Leeuw (1955:380), was popularly represented as Sūrya in Bali. If our reasoning is correct, the deity of the West-facing panel could represent Rudra as the ‘angry’ manifestation of Sūrya (as well as Śiva). A link between Rudra and Sūrya may be detected in early Brahmanic mythology, where Rudra is one of the twelve Ādityas – who themselves are sometimes referred to as forms of Sūrya. Furthermore, one of Sūrya’s 108 names is Rudra (Bunce 2000:451). The association, or even conflation, of Rudra and Sūrya is apparently due to the fierce nature and appearance of both deities. For the same

⁴⁵ If Jordaan had a point in arguing for Tonnet’s identification of the West-facing deity as Nairṛta, he went astray when he extended the identification to the South-facing deity to comply with Van Lohuizen-de Leeuw’s model in which each Lokapāla is represented twice. Failure to give due recognition to the iconographic differences between the two reliefs thus prevented him and Van Lohuizen-de Leeuw from arriving at a more comprehensive solution.

⁴⁶ See Setianingsih 1995; Maulana Ibrahim 1996:56; BPPP Yogyakarta 2007:130; Degroot, Grif-fiths and Baskoro Tjahjono forthcoming; our note 39.

reason, Rudra is often identified with Agni.⁴⁷ In a Balinese Sanskrit Stuti (363), which constitutes a litany to the nine regents of the regions of the sky, Rudra is characterized as having the form of Fire (*agni*) and Sun (*sūrya*), a terrible or angry (*krūra*) appearance, and a 'fire-lotus' (*padmāgni*) as attribute.⁴⁸ This detail would seem to be in harmony with the relief (D10) depicting the West-facing deity, who carries an open lotus topped by an object that, rather than a jewel or sunstone, might represent some kind of burning substance (see Figure 7).⁴⁹ Note that the Āditya form of Rudra is described by Bunce (2000:451) as holding a lotus on two of his four hands – an iconographic feature that distinguishes Sūrya too. Speaking in favour of the identification of Sūrya as the deity depicted in the South-facing panel is an image of Sūrya found in Pāhārpur,⁵⁰ in which the deity bears a lotus mark on his forehead and holds a flower (lotus?) blossom in his right hand – in contrast with the 'usual' form of Sūrya holding two full-blown lotuses (Mevisen 2009:397); compare the Sūrya in our relief, who holds in his left hand a stalk topped by a lotus blossom.

Although we find the visual evidence in support of the identification of the South-facing deity as Sūrya to be strong, in view of the parallel existence in both South Asia and Java of two traditions placing either Sūrya or Nairṛta in the Southwest,⁵¹ we are obliged to leave this matter open. The uncertainty surrounding the identification of the South-facing deity, however, does not stand in the way of our proposal to identify the West-facing deity as Rudra, a fierce and demonic form of Śiva who is appropriately placed in the inauspicious Southwest, and who may be fittingly paired with either Sūrya or Nairṛta.

5. West (Groneman 1893:21, panels D12 and D13, plates XLVI and XLVII).

Both Tonnet and Van Lohuizen-de Leeuw (1955:378) maintain that Varuṇa is represented twice, for both figures carry the god's characteristic attribute *nāgapāśa*. Van Lohuizen-de Leeuw, however, disagrees about the attribute carried by the deity's first follower on the right (D12/XLVII), seeing it as a winged conch-shell rather than a sunshade (*ābhoga*). The attendants to the left of the deity seem to carry small objects, probably gems or fruits.

⁴⁷ See the elaborate and interesting discussion on the identification of Rudra and Agni in late Vedic, Puranic and Epic Sanskrit sources by Bosch (1924:246-74).

⁴⁸ Stuti 363.13: 'Rudra is the God in the Southwest; Rudra's form is that of Fire and Sun. He has the colour of fire, very horrible; His weapons are the fire-lotus and the club' *rudram tu deva nairṛtyām rudrāgnisūryaṅ ca rūpam | agnivārṇa mahākṛūra padmāgni astra mokṣalam*.

⁴⁹ It is possible that the object topping the closed lotus bud carried by the deity of the South-facing panel D9 could also have a burning nature, as alluded to by the small cloud of smoke hanging over it (see Figure 6).

⁵⁰ Mevisen 2009:396-7. This Buddhist *vihāra*, located in present-day Bangladesh, is interesting not only because it is decorated mainly with Brahmanic gods, but especially because it is believed to have architectural and iconographic connections with Prambanan (see Jordaan 1996:41-2, 100-1).

⁵¹ See, for instance, the list given in various passages of the *Manusmṛti* (between circa 200 BC and 200 AD), replacing Nairṛti by Arka (Sun) (see Mevisen 2009:393 and 400, note 9).

It is difficult to establish which of the two panels could represent Mahādeva, the Digbandha of the West. The snare (*pāśa*) is listed as an attribute of Mahādeva by Liebert (1976:157); and the *varadamudrā*, displayed by the god in the left-hand panel (D13/XLVII), has been attributed to both Varuṇa (see Liebert 1976:331) and Mahādeva (see Bunce 2000:315, 317). We provisionally place Varuṇa in the left-hand panel.

6. *Northwest* (Groneman 1893:21-2, panels D15 and D16, plates XLIX and L; our Figs. 8 and 9).

Both Tonnet and Van Lohuizen-de Leeuw identify both panels as depicting Vāyu in his *gandhavaha* form, on account of the burning incense that both deities seem to carry on top of a lotus. However, the object carried by the deity of the North-facing panel (D16, plate L; see Figure 9) is slightly different from the one depicted in panel D15 (plate XLIX, see Figure 8); it consists of three distinct flames – instead of one – emerging from a bell-shaped object placed on a large lotus bud (or flower?). As Van Lohuizen-de Leeuw (1955:373) notes, in some representations of Navasaṅas on Balinese textiles Śaṅkara is given an *aṅkusa* or a sort of *daṇḍa*. In the drawing by Ida Made Rai⁵² it is an object that branches into three flames, but the inscription refers to it as an “*angkoēs*”; this makes her wonder ‘whether this queer object could be related to the incense, also burning with three flames on Vāyu’s lotus at Loro Jonggrang [panel D16/plate L]’.

The object in question is not clear enough to allow us to positively identify the deity depicted on panel D16. Purely on account of his correspondence with the sequential order of the postulated series of deities, we tentatively propose the form of Śiva known as Śaṅkara.⁵³

7. *North* (Groneman 1893:22, panels D18 and D19, plates LII and LIII).

Tonnet identifies Kubera to the right and Soma to the left of the steps, whereas Van Lohuizen-de Leeuw claims that both panels represent Kubera. Rejecting Tonnet’s identification of the soma plant and a moonstone (*candrakānta*) as the attributes borne by the attendants of the main deity in panel D19 (plate LIII), Van Lohuizen-de Leeuw (1955:378) argues that ‘as we have found the guardians of the South and West twice, we see no reason why Kuvera should not be represented twice on the North’. According to Van Lohuizen-de Leeuw, attributes of the two main figures, a conch-shell (*śaṅkhanidhi*) on a lotus flower and a jewel on a lotus flower, are commonly found in the iconography of Kubera in the Indian subcontinent. We prefer to identify the former attribute

⁵² Compare the drawings by I Ketut Budiana and I Gusti Nyoman Mirdiana in Stephen 2005:126, 128.

⁵³ The attributes carried by some of the attendants in both panels, namely a variety of lotuses, either in flower or still closed, or some other kind of flowers, do not help us to clarify the matter.

as a winged conch-shell, which is actually an attribute of Viṣṇu. The second attribute, which is not very clear, may well represent a fruit or a closed lotus bud. The attendants to either side of the main figures in both panels seem to be *yakṣas*, which are usually associated with Kubera.

In agreement with both Tonnet and Van Lohuizen-de Leeuw, we identify the deity depicted in the panel to the right of the staircase as Kubera; however, we reject both Tonnet's speculative identification of the other deity as Soma and Van Lohuizen-de Leeuw's alternative identification as Kubera. We believe that the two figures cannot possibly represent one and the same deity since the figure of panel D18 (plate LII), besides displaying the *varada mudrā* peculiar to Kubera, has a dwarfish shape and a prominent pot-belly, whereas the body of the other figure is normal in appearance and well-proportioned.

The Digbandha of the North is Viṣṇu; since the attributes represented in the two panels may be associated with both Viṣṇu and Kubera, we identify the latter deity purely on the basis of his physical features. A position in the North would be entirely appropriate for a figure representing Viṣṇu given that it would face the secondary temple to the North dedicated to him. As seen earlier, this was likewise the case for the figure we identified earlier as Brahmā, which faces the secondary Brahmā temple to the South.

8. *Northeast* (Groneman 1823:22-3, panels D21 and D22, plates LV and LVI). Both Tonnet and Groneman identify these two figures as the Lokapāla Īśāna, himself a form of Śiva, from the presence of unmistakable Śaiva attributes such as the trident (*triśūla*) and the skull (*kapāla*) displayed next to the main deities of both panels. According to Van Lohuizen-de Leeuw, the attendants in the East-facing panel are Gaṇas – Śiva's attendants – on account of their 'childish jewelry and rounded eyes'.

We prefer to identify the deity of the East-facing panel as the form of Śiva called Śambhu, the Digbandha of the Northeast. This deity represents the calm or benevolent form of Śiva-Rudra. The serene and smiling expression of the figure depicted in the panel is entirely consistent with the mild nature of Śambhu, who presides over the auspicious Northeast (as opposed to the inauspicious Southwest).

Series III: The eight interstitial Digbandhas

As pointed out at the beginning of this article, Tonnet's identifications of the eight deities do not conform to any known octad of Brahmanic or Śaiva divinities, nor to any specific iconographic master plan. Rather, Tonnet proposes them simply on the basis of internal evidence such as the iconographic features displayed by the main figures depicted in the reliefs, and their placement insofar as it might relate to the cardinal directions of the Lokapālas.

In our opinion, Tonnet's identifications for most of the eight interposed deities are unlikely due to the limited criteria she used. As we review Tonnet's identifications we also advance our own by comparing the intrinsic iconographic features of the reliefs with the iconographic scheme that we postulate.

1. *Between East and Southeast* (Groneman 1893:20, panel D2, plate XXXVI). Tonnet (1908:142) identifies the deity depicted on the panel as Bṛhaspati, calling him the teacher of the gods as well as their private priest (*purohita*). She regards the *kamaṇḍalu*, which she calls *loṭa*, on top of the stand, on the deity's left, as his most characteristic attribute. The other attributes – a trident, fly whisk, alms bowl, and rosary – in her view merely indicate Bṛhaspati's position as a Śaiva priest. Some of the same attributes are also visible among the attendants in the flanking reliefs. Four attendants are fully bearded and wear a sacred thread (*upavīta*), just like the deity in question. The first non-bearded attendant on the deity's right wears a string of prayer beads instead of a sacred thread.

At the end of her discussion, Tonnet refers to Groneman's previous tentative identification of the deity of the central relief as 'Guru', that is, Śiva as teacher and ascetic. She wonders whether the figure could represent a merger between the teacher of the gods Bṛhaspati and Śiva as Great Ascetic (Mahāyogin), resulting in the Javanese form known as Bhaṭāra Guru. Primarily based on characteristic features such as the trident, she concludes that it might be possible to view the main figure in this relief as a manifestation of Śiva.

Though it is clear that the image represents an ascetic and priest-like figure, the few attributes associated with this divinity are not specific enough to enable us to positively identify him as Bṛhaspati. In addition to Bṛhaspati, for example, ascetics, beggars, and Brahmans are commonly represented in association with the *kamaṇḍalu* (see Liebert 1976:155). Apart from the rosary (*akṣamālā*) and water jar (*kamaṇḍalu*), Bṛhaspati's other usual attributes – the staff (*daṇḍa*), bow (*dhanus*), axe (*paraśu*), book (*pustaka*), and arrow (*śara*) – are absent from this relief (see Liebert 1976:48). Still, we find Tonnet's (and Groneman's) suggestion to identify the figure as a form of Śiva emphasizing his aspect of Guru and ascetic quite convincing.⁵⁴ All the attributes of the main deity are part of the iconography of ascetic forms of Śiva; his beard, moustache and other elements of his Brahmanic attire are strongly reminiscent of the iconography of Agastya, who in Java is still often referred to as Śiva 'Bhaṭāra Guru'.

The interstitial deity between East and Southeast in our series of 16 Digbandhas is Dharma. In Sanskrit literature, Dharma is an epithet of the

⁵⁴ We do not, however, find any good reason to support Tonnet's hypothesis about the figure being a 'merging' between Bṛhaspati and Śiva as Guru.

infernal god Yama. This also happens to be the case in mainstream Brahmanic literature in Old Javanese, where Bhaṭāra Dharma is often used as a synonym of Yama.⁵⁵ However, Bhaṭāra Dharma is also known in Old Javanese Śaiva scriptural literature, where it apparently refers to a form of the Lord Śiva rather than Yama.⁵⁶ Since the figure depicted in the panel obviously represents a manifestation of Śiva, the figure may be identified as the latter Dharma. Although nothing is known about the iconography of Śiva as Dharma, it may well be the case that he shares the same features that are attributed to a form of Śiva as ascetic and teacher.

2. *Between South and Southeast* (Groneman 1893:20, panel D5, plate XXXIX; our Figure 10).

Calling it ‘a very curious relief’, Tonnet (1908:143) takes the central image to be Hanumān ‘in the guise of a god, which he is according to his birth’. Hanumān is the son of Vāyu, god of the wind, and the nymph Añjanā, who was expelled from heaven in the form of a monkey. Allegedly, Añjanā is seated on Hanumān’s left in the company of *gandharvas*, to whom she is said to belong. Tonnet sees the object on top of the flower in Hanumān’s left hand as a club, calling it the usual weapon of monkeys. The club seems to have three ribbons or flames. On Hanumān’s right, according to Tonnet, Mount Gandhamadana, abode of the *gandharvas*, is sculpted. Their rulers Hāhā and Huhū seated in front of the mountain. On the other side of the mountain, a medicinal herb is depicted, which Hanumān used in his battle against Rāvaṇa, in order to revive the dead. Tonnet contends that the position of Hanumān has a special meaning, considering that the relief is found on the southern side of the temple, between Yama and Agni. To support her identification, Tonnet points to the absence of the *senté* leaf, supposedly an emblem of royalty, which is consonant with the fact that Hanumān was not a king.

We find Tonnet’s identification unconvincing. To begin with, we cannot discern any mountain in the relief to the deity’s right, only heavily damaged edges. There is nothing to indicate that the flowering shrub is a medicinal herb. The plant could well represent a wish tree similar to those found in other reliefs of the Prambanan temples (see OD photographs 4292-9). Furthermore, Tonnet does not explain why Hanumān should have been depicted in the guise of a god instead of in his normal form as a monkey. The reverse applies to Añjanā. Tonnet is also somewhat ambiguous about Hanumān’s status – recognizing him as a god, but denying him royal status. The halo may indicate the figure’s divine or semi-divine status, but the absence of the *senté* leaf is more difficult to interpret. Tonnet fails to explain why we should see it as an emblem of royalty in the first place. We disagree

⁵⁵ See, for example, *Agastyaparva* 355.14.

⁵⁶ See, for example, *Tattvajñāna* 5, 6, 26, 29, 30, 33; *Saṅ Hyaṅ Hayu* 3b, 35b, 36b, 56a.

with her as regards the identification of the object on the flower as a club. Following Groneman, we see the object as a sword because of the presence of a hilt with hand guard. Ironically, the sword (*khaḍga*) is also a symbol of royalty (Liebert 1976:134), a status which Tonnet does not attribute to Hanumān. Another point about her proposed identification is that many monkeys are depicted in the small niches on each of the four sides of the Śiva temple. Since Tonnet sees all these monkeys as representations of Hanumān, his presence in this particular relief seems superfluous to us. As for the virtual monkey among the attendants in the right-hand panel, we have no idea how Tonnet could tell it was a she-monkey.

The interstitial Digbandha between South and Southeast is Kāla, a demonic or angry form of Śiva, also called Bhairava or Bhīma ('the terrible'). This identification is appropriate for the figure in question, which displays an angry (*krodha*) aspect with bulging eyes.⁵⁷ In the Indian subcontinent, and especially in Java and Bali, Bhīma/Bhairava is associated with Hanumān. Some traditions see in the latter a manifestation of the former,⁵⁸ whereas others regard both Bhīma and Hanumān as brothers, both being sons of Vāyu (Wind). We see the cloud depicted above Hanumān as a visual representation of the Wind. On account of the appearance of Hanumān – who, notably, displays the same demonic characteristics as the main figure, having protruding eyes and prominent fangs – in his retinue, it seems appropriate to identify the main deity of the panel as Kāla.

3. *Between South and Southwest* (Groneman 1893:20, panel D8, plate XLII).

Tonnet (1908:143-4) views the deity as representing Brahmaṇaspati, calling him 'the priest's prayer personified'. She regards the object on top of the deity's flower as a sacrificial flame. The deity is venerated by heavenly *ṛṣis* and earthly Brahmins. Tonnet observes that two of the attendants carry torches, two others long-handled sacrificial offering spoons, with the final two attendants displaying a venerating hand gesture, but her description is not entirely accurate. Only one attendant carries a torch and only one a long-handled ladle. One other attendant holds a small object that to us resembles a priest's bell rather than a torch. Pointing to their seemingly open mouths, Tonnet believes the attendants are represented as engaged in the act of singing or chanting.

As an alternative identification, Tonnet proposes Hanumān 'in view of the fact that he is represented on either side of Yama, with a priest's cap and band

⁵⁷ Actually, Kāla is often associated with the infernal god Yama, and Kāla may even be used as an epithet of Yama. It is therefore appropriate that Kāla appears between Agni (SE) and Yama (S).

⁵⁸ Lutgendorf 1997; Kieven 2011:225-7. Hanumān and Bhīma are a popular couple in Bali (see Kieven 2011 and Vickers 2011), but the links between the two go back many centuries, to the appearance of statues of Hanumān with Bhīma-like features in the Majapahit period (see Klokke 2006). Klokke connects the appearance of these statues with the growth of a Bhīma cult, which coincides with developments in the worship of Hanumān in India.

on the left. This [identification] deserves further investigation.’ Groneman, on the other hand, identifies the deity as ‘Agni as Bodhisattva’, mainly on account of the flame on top of the lotus.

We reject Tonnet’s identification as Hanumān because it is cryptic and premature, and the identification as Brahmaṇaspati because it is based only on general and non-specific attributes carried by the main deity and the members of his retinue. Agni’s candidacy, advanced by Groneman, is also to be rejected in view of the presence of that divine figure among the eight main Lokapālas.

The interstitial Digbandha between South and Southwest is Mṛtyu (‘death’). Mṛtyu often features in Sanskrit sources as a personification of Yama, being represented with his attributes. The word may be used as an epithet of Yama or as an epithet of Sūrya; hence his depiction between the Lokapāla Yama and the Lokapāla Sūrya seems correct. Other Sanskrit traditions identify Mṛtyu as a son of Nirṛti by Adharma (Bunce 2000:9) or of Kālī and Brahmā; also in this case, Mṛtyu appearance between Nairṛti, the Lokapāla of the Southwest – if the Lokapāla does not represent Sūrya – and Brahmā, the Digbandha of the South, is appropriate.

In Sanskrit and Old Javanese sources, Mṛtyu is associated with Kāla – the interstitial Digbandha between South, Yama’s direction, and Southeast, with whom he forms a pair; both are associated with Yama and can be evoked in place of that god.⁵⁹ In the Old Javanese Kakawin *Rāmāyaṇa* (11.1c), Kāla and Mṛtyu are associated with fire – a blazing fire that burns everything in all directions just like Kāla and Mṛtyu do. The Balinese Sanskrit *Rudrastava* (Stuti 727) associates Kāla and Mṛtyu not only with the terrifying Rudra but also with Agni: ‘He is Kāla, Mṛtyu, and a terrible demon; [everything] is reduced to ashes by the Eater of the Oblation (= Agni, ‘fire’).’⁶⁰ This description helps to explain the presence of the fire carried by the main deity on the lotus and the sacrificial implements carried by members of his retinue,⁶¹ and also the *krodha* form of the Digbandha, which is evoked by his protruding eyes and frown, features that are shared by most of his attendants.

4. *Between Southwest and West* (Groneman 1893:21, panel D11, plate XLV).

The deity is tentatively identified as Sūrya by Tonnet (1908:140), on account of the jewel-topped lotus he carries. This identification is unlikely in view of Sūrya’s primary importance, as a manifestation of Śiva, in the Javano-Bali-

⁵⁹ See, for instance, the pre-tenth-century copper plates of Kuṭi (Sarkar 1971, I:82), Vuatan Tija (Sarkar 1971, I:253), Wukajana (Sarkar 1971, II:90, where this plate is incorrectly grouped with the Sangsang plate under one heading), Kavi (Sarkar 1971, II:250), and Gilikan I (Sarkar 1971, II:271).

⁶⁰ Stuti 727, 5cd: *kālamṛtyu yakṣas rodrām bhasmībhūta hutāśanam*.

⁶¹ Interestingly, association with fire, sacrifice, and demons appears to have been implied in the list of deities found in the copper plate of Gilikan I (Sarkar 1971, II:271, b3), mentioning side by side Hutāśana (‘oblation-eater’, that is Agni), Yajamāna (‘sacrificer’), Kāla, Mṛtyu, Gaṇas and Bhūtas (demons).

nese pantheon. Given his prominent status, it is unlikely that Sūrya would be placed among the eight interstitial deities; we would rather expect Sūrya to appear among the main Lokapālas.⁶²

The Digbandha between Southwest and West is the angry form of Śiva known as Krodha. This identification fits the iconographic features of the relief, where the main deity as well as his attendants have fierce appearances and angry faces. The attribute carried by the main deity on top of a lotus cannot be identified with certainty; it looks like a (flaming?) jewel or a fruit.

5. *Between West and Northwest* (Groneman 1893:21, panel D14, plate XLVIII). In Tonnet's opinion (1908:144), the deity represented here is Kārttikeya or Skanda, the god of war, in his capacity as Senāpati, leader of the armies of the gods. Two of his attributes are visible: the trident on his right, and the bow with a downwards-pointing arrow on his left. The attendants bear lotus flowers.

The attributes displayed by the figures in the relief are too few and too indistinct to support the identification proposed by Tonnet. On the contrary, we find evidence supporting the identification of the main deity as Viśva, Digbandha between West and Northwest. In the present instance, Viśva arguably stands for Viśvakarman and thus may represent a form of Śiva manifested in Viśvakarman, the architect and artisan of the gods according to Brahmanic mythology. The presence of the trident and the bow may allude to the fact that Viśvakarman is credited with the construction of both Śiva's and Viṣṇu's powerful weapons, a trident and a bow respectively. Further, one of Viśvakarman's epithets is *sudhanvan*, 'having a good bow'.

6. *Between Northwest and North* (Groneman 1893:22, panel D17, plate LI). Groneman tentatively identifies the main deity in this relief as Rāma. However, he previously mentioned Rāma in connection with plate XXXIX. Tonnet (1908:144) believes Kāma, god of love, to be represented in this relief, depicted as Puṣpaśara, meaning 'whose arrows are flowers'. His attributes are a sugarcane bow with a string of bees, and five flower arrows. The deity in question holds a bow and arrow in his left hand. Supposedly, his retinue comprises *apsarases* in accordance with Brahmanic mythology. Tonnet alleges that one of the heavenly nymphs holds a banner displaying a *makara* or a fish. The first nymph on the deity's left is kneeling in front of what seems to be a pedestal, which supports a lotus flower with a flame at the top.

⁶² As posited by Van Lohuizen-de Leeuw (1955:380) and, with some uncertainty, by ourselves with respect to the deity depicted in panel D9 in the Southwest. See also Jordaan and Sedyawati 1990, who see Sūrya in one of the higher-level deities depicted over the lintels of the temple chambers.

There is nothing to show that the deity's bow is made of sugar cane or that the one arrow visible is a flower arrow. We cannot detect the banner with a fish either; perhaps Tonnet mistook the long-stalked lotus flower held by the *apsaras* in the middle of the right-hand relief for a banner. In spite of these inaccuracies, Tonnet's identification of the main figure as Kāma seems plausible to us, for both his attributes (bow and arrow) and his retinue (*apsarases*) are compatible with the iconography of Kāma. Furthermore, Tonnet's identification fits our postulated series of Digbandhas, which has Kāma as the ruler between Northwest and North. In this role, Kāma is to be regarded as a manifestation of Śiva; compare the Balinese Sanskrit Stutis 70 and 73, which are entirely devoted to the praise of Kāma as a form of Śiva.

7. *Between North and Northeast* (Groneman 1893:22, panel D20, plate LIV). Tonnet (1908:144) tentatively identifies this deity as Viśvakarman, architect of the gods. Although the lotus itself was destroyed, Tonnet contends that the object on top of this lost flower represents Viśvakarman's famous fire-weapon. The deity's wife was a Wānarī monkey, who is not shown in the relief, however. Tonnet believes that the woman on the deity's right side represents his mother, Yogasiddhā. Tonnet views the attendants as Viśvakarman's helpers and students: three Ṛbhu's, who were famous semi-divine craftsmen. The countenance of the first attendant on the deity's left is reminiscent of a demon (*rākṣasa*), but Tonnet admits that she found no mention of this in the literature. The attendant to the deity's right holds a jewel in his left hand, while the Ṛbhu in the middle holds a sacrificial cup. This object reminded Tonnet of the contest in which the Ṛbhu had to make four sacrificial cups out of the single cup forged by their master.

We find Tonnet's identification unacceptable. In our opinion, the identification of the female attendant as Yogasiddhā is highly conjectural and there is no iconographic element that would enable us to identify the other three figures as the three Ṛbhu (Ṛbhu, Vāja and Vibhu), especially given that one of the attendants is depicted as a demon.

The principal iconographic features displayed by the main deity in this relief are his jewelled girdle, benevolent and calm face, and three eyes; his attribute appears to be a spear with a spike surrounded by flames. All of these features are compatible with the iconography of the benevolent form of Śiva known as Paśupati (see Bunce 2000:405). The Digbandha between North and Northeast is likewise Paśupati. The spear may represent the terrible *pāśupatāstra*, the weapon of Paśupati, described in the Old Javanese Kakawin *Arjunavivāha* (27.1) as emanating a destructive fire (*agni*) from its point, which transforms itself into an army of millions of demons (*rākṣasa*). The fierce-looking *rākṣasa* to the left of the deity might be an allusion to this peculiar property of the *pāśupatāstra*. But Paśupati is also the Lord of the *gaṇas* and

bhūtas, a class of demi-gods and demons attending Śiva; hence the appearance of a demon in the retinue does not seem inappropriate.

8. *Between Northeast and East* (Groneman 1893:22, panel D23, plate XLVII).

Tonnet (1908:145) identifies the main deity as Nārada, messenger of the gods, based on her belief that the builders of the Śiva temple would have deemed Nārada to be an indispensable member of the deities. As this was the only relief left that she could connect with Nārada, she conjectures that this figure must represent him. However, Tonnet admits that she could find little information about this deity in the available sources, and she concedes that the staff-zither (*vīṇā*) found in Coleman's study is not shown in the relief.

Nārada is the son of Brahmā and Sarasvatī. Apart from serving as messenger of the gods, he is also known as a wise lawgiver, an astronomer, and an excellent musician. In Tonnet's opinion, some of the attributes depicted here seem to represent the qualities or talents attributed to Nārada. For instance, she identifies the attendants to the deity's right as the heavenly musicians known as *gandharvas*. She proposes that the attendant in the middle is playing the *vīṇā* while holding the sound box of the musical instrument on top of his shoulder. In the book that rests on top of the lotus flower on the left of the deity she sees a 'book of law'; and on his right she sees a food offering consisting of a tray of rice covered with flowers.

We find Tonnet's identifications for several of these details implausible. The book on top of the lotus could well be a law book, but no detail supports this. It is also hard to decide whether the object to the deity's right is a food offering. Besides, Tonnet, for unspecified reasons, denies this indistinct object the status of attribute. Following Groneman, we take the object in question to be a globe. The identification of the attendants' attributes is ambiguous. For instance, Groneman sees the alleged *vīṇā* as a bow, and the object near it as a sacrificial spoon.⁶³ Furthermore, Groneman considers the relief's main divinity to depict 'Yama as Bodhisattva', which is an unacceptable identification for inclusion among the Lokapālas depicted on a temple dedicated to Śiva.

The Digbandha between Northeast and East is Satya. This minor deity, who is intended here as a manifestation of Śiva, is found in South Asian representations carrying a lotus, manuscript, and sacrificial spoon as attributes (see Bunce 2000:490). The appearance of these objects in this relief seem to support such an identification.

⁶³ Since we cannot see the sound box of the *vīṇā* described by Tonnet, and since the object in question, as suggested by Groneman, looks more like a bow, we suspect that she mistakenly refers to the attendants on the right of the deity instead of those on his left. The middle attendant of the latter series does carry an object that could well be a *vīṇā*, with its sound box lying on the figure's shoulder.

Conclusion

According to Tonnet (1908) and van Lohuizen-de Leeuw (1955), the relief panels placed in the eight compass directions of Caṇḍi Śiva represent a series of eight Brahmanic Lokapālas, each of which is depicted twice. Though we accept the identification as Lokapālas, we challenge the view that they are depicted in pairs. In contrast, we argue that the planners of the temple sought to merge an established series of eight Brahmanic Lokapālas with another series of Śaiva Digbandhas, both series sharing major attributes and, in some cases, certain iconographic features. This possibility was indeed envisaged by van Lohuizen-de Leeuw herself, but not pursued further. She touches on the possibility that the merging of the two series documented in the East Javanese and Balinese tradition originated in the Central Javanese period.

Further, rejecting Tonnet's conjectural identifications of the eight interstitial deities placed between the gods of the eight principal directions, we point out that the former series is attested in certain Old Javanese sources precisely in connection with the 'interstitial' directions of the compass. This series of eight deities is included in a series of 16 Śaiva Digbandhas representing both manifestations and the retinue of Śiva, who is encircled by them. Having found this cosmological conception to be in harmony with the iconographic master plan of Caṇḍi Śiva and, from a wider perspective, of the three temples forming the core of the Loro Jonggrang temple complex, we checked our alternative identifications against the available art-historical evidence and discussed its compatibility with the features of each of the reliefs. Most of the new identifications are confirmed by iconographic data known from either South Asian visual and textual sources, or Old Javanese textual sources; for the remaining deities, for whom no conclusive identifications could be advanced, we propose tentative identifications on the basis of correspondence with the cosmological model attested in Śaiva Old Javanese texts.

Our hypothesis, if correct, bears implications for Javanese art history, entailing as it does a correspondence between the iconography and conceptual plan of the Loro Jonggrang complex and Old Javanese Śaiva texts. Our findings also have important implications for the history of Śaivism in Java, suggesting the possibility that the Sanskrit/Old Javanese Tuturs and Sanskrit Stutis from which we drew our data – in spite of having been transmitted through much later Balinese manuscripts of uncertain chronology – reflect a state of doctrinal development dating from ninth-century Java.



Figure 6. Sūrya (or Nairṛta?) (detail of panel D 9; photo Kassian Cephas, Leiden University Library, Kern Institute, P-044561)



Figure 7. Rudra (detail of panel D 10; photo Kassian Cephas, Leiden University Library, Kern Institute, P-044562)



Figure 8. Vāyu (detail of panel D15; photo courtesy Mark Long, 2004)



Figure 9. Śaṅkara (detail of panel D16; photo Kassian Cephas, Leiden University Library, Kern Institute, P-044568)



Figure 10. Kāla (panel D5; photo courtesy Mark Long, 2004)

References

Primary sources

- Agastyaparva*, see Gonda 1936.
Arjunavivāha, see Robson 2008.
Bhuvanakośa, romanized transcript by I Gusti Ngurah Rai Mirsha et al. Pusat Dokumentasi Budaya Bali, Denpasar (1991).
Bhuvanasaṅkṣepa, see Lokesh Chandra 1997.
Brahmāṇḍapurāṇa, see Gonda 1932.
Dharma Pātañjala, see Acri 2011b.
Pañcāvaraṇastava, see Goodall et al. 2005.
Saṅ Hyāṅ Hayu, see Darsa 1998.
Stuti and Stava, see Goudriaan and Hooykaas 1971.
Tattvajñāna, see Sudarshana Devi 1962.
Vṛhaspatitattva, see Sudarshana Devi 1957.

Secondary sources

- Acri, Andrea
 2006 'The Sanskrit-Old Javanese Tūtur literature from Bali: The textual basis of Śāivism in ancient Indonesia', *Rivista di Studi Sudasiatici* 1:107-37.
 2011a 'Glimpses of early Śāiva Siddhānta: Echoes of doctrines ascribed to Bṛhaspati in the Sanskrit-Old Javanese *Vṛhaspatitattva*', *Indo-Iranian Journal* 19:209-29.
 2011b *Dharma Pātañjala: A Śāiva scripture from ancient Java, studied in the light of related Old Javanese and Sanskrit texts*. Groningen: Egbert Forsten Publishing.
 Bosch, F.D.K.
 1924 'Het Lingga-Heiligdom van Dinaja: Met naschrift van B. Schrieke', *Tijdschrift voor Indische Taal-, Land- en Volkenkunde (TBG)* 64:227-291.

- BPPP Yogyakarta
2007 *Pusaka Aksara Yogyakarta: Alih Aksara dan Alih Bahasa Prasasti Koleksi badan pelestarian Peninggalan Purbakala Yogyakarta*. Yogyakarta: BPPP.
- Brunner, H., G. Oberhammer and A. Padoux
2000 *Tāntrikābhidhānakośa I. Dictionnaire des termes techniques de la littérature hindoue tantrique*. Wien: Verlag der Österreichischen Akademie der Wissenschaften. [Beiträge zur Kultur- und Geistesgeschichte Asiens 35.]
- Bunce, Fredrick W.
2000 *An encyclopaedia of Hindu deities, demi-gods, godlings, demons and heroes: With special focus on iconographic attributes*. Illustrated by G.X. Capdi. New Delhi: D.K. Printworld.
- Coleman, C.
1832 *The mythology of the Hindus, with notices of various mountain and island tribes, inhabiting the two peninsulas of India and the neighbouring islands: and an appendix, comprising the minor avatars and the mythological and religious terms [...]*. London: Parbury, Allen.
- Crucq, K.C.
1936 'De windroos van Tjandi Soemberdjati (no. 5668 Museum)', *Tijdschrift voor Indische Taal-, Land- en Volkenkunde (TBG)* 76:340-3.
- Damais, L.-C.
1969 'Études javanaises III: A propos des couleurs symboliques des points cardinaux', *Bulletin de l'Ecole française d'Extrême-Orient* 56:75-118.
- Darsa, Undang A.
1998 *Sang Hyang Hayu: Kajian Filologis naskah Bahasa Jawa Kuno di Sunda pada abad xvi*. Bandung: Program Pascasarjana Universitas Padjadjaran [Master of Humanities Thesis, Universitas Padjadjaran.]
- Degroot, Véronique, Arlo Griffiths and Baskoro Tjahjono
forthcoming 'Les pierres cylindriques inscrites du Candi Gunung Sari (Java Centre, Indonésie) et les noms des directions de l'espace en vieux-javanais', *Bulletin de l'Ecole française d'Extrême-Orient* 97-98 (2010-2011).
- Gonda, J.
1932 *Het Oud-Javaansche Brahmāṇḍa-Purāṇa: Prozatekst en kakawin uitgegeven en van aanteekeningen voorzien*. Bandoeng: Nix.
1936 *Agastyaparwa: Uitgegeven, gecommenteerd en vertaald door J. Gonda*. N.p.: n.n. [Reprint of *Bijdragen tot de Taal-, Land- en Volkenkunde* 90, 1933, pp. 329-419; 92, 1935, 337-458; 94, 1936, pp. 223-45.]
- Goodall, Dominic et al. (eds)
2005 *The Pañcāvaraṇastava of Aghoraśivācārya: A twelfth-century South Indian prescription for the visualization of Sadāśiva and his retinue: An annotated critical edition*. [Pondichéry]: Institut français de Pondichéry, [Paris]: École française d'Extrême-Orient.
- Goris, R.
1954 *Prasasti Bali I: Inscripties voor Anak Wungçu*. Bandung: Masa Baru (Lembaga Sastra dan Budaya, Faculteit Sastra dan Filsafat, University of Indonesia).
- Goudriaan, T. and C. Hooykaas
1971 *Stuti and stava (Bauddha, Śaiva and Vaiṣṇava) of Balinese brahman priests*. Amsterdam/London: North-Holland Publishing Company.

- Groneman, J.
1893 *Tjandi Prambanan op Midden-Java na de ontgraving*. Leiden: Brill.
- Hooykaas, C.
1966 *Sūrya-Sevana: The way to God of a Balinese Śiva priest*. Amsterdam: Noord-Hollandsche Uitgevers Maatschappij.
- Ibrahim, Maulana
1996 *Kompleks Candi Prambanan dari masa ke masa*. N.p.: Direktorat Perlindungan dan Pembinaan Peninggalan Sejarah dan Purbakala.
- Jordaan, Roy E.
1992 'Sūrya and Nairṛta on the Śiva temple of Prambanan', *Bijdragen tot de Taal-, Land- en Volkenkunde* 148:59-66.
1996 *In praise of Prambanan: Dutch essays on the Loro Jonggrang temple complex*. Leiden: KITLV Press. [Translation Series 26.]
- Jordaan, Roy E. and Edi Sedyawati
1990 'Some iconographic notes on the Śiva temple at Prambanan', *Archipel* 40:15-23.
- Kieven, Lydia
2011 'Hanuman, the flying monkey: The symbolism of the *Rāmāyaṇa* reliefs at the main temple of Caṇḍi Panataran, in: Andrea Acri, Helen Creese and Arlo Griffiths (eds), *From Lan̄kā eastwards: The Rāmāyaṇa in the literature and visual arts of Indonesia*, pp. 209–232. Leiden: KITLV Press. [Verhandelingen 247.]
- Kirfel, W.
1959 *Symbolik des Hinduismus und des Jainismus*. Stuttgart: Hiersemann.
- Klokke, Marijke J.
2006 'Hanuman in the art of East Java', in: Truman Simanjuntak et al. (eds), *Archaeology: Indonesian perspective: R.P. Soejono's festschrift*, pp. 391-405. Jakarta: LIPI Press.
- Kramrisch, S.
1976 *The Hindu temple*. Delhi: Motilal Banarsidass. Two vols.
- Krom, N.J.
1923 *Inleiding tot de Hindoe-Javaansche kunst*. Tweede herziene druk. 's-Gravenhage: Nijhoff. Three vols. [First edition 1920.]
- Levin, Cecelia S.
1999 *The Rāmāyaṇa of Loro Jonggrang: Indian antecedents and Javanese impetus*. PhD dissertation, Institute of Fine Arts, New York University. [Ann Arbor, Michigan: UMI Microfilm 9930225, 2000.]
- Liebert, Gösta
1976 *Iconographic dictionary of the Indian religions: Hinduism-Buddhism-Jainism*. Leiden: Brill. [Studies in South Asian Culture 5.]
- Lohuizen-de Leeuw, J.E. van
1955 'The Dikpālakas in ancient Java', *Bijdragen tot de Taal-, Land- en Volkenkunde* 111:356-84.
- Lokesh Chandra
1997 'Bhuvana-saṅkṣepa: Śaiva cosmology in Indonesia', in: Lokesh Chandra (ed.), *Cultural horizons of India*. Vol. 5, pp. 102-61. New Delhi: International Academy of Indian Culture and Aditya Prakashan.

- Long, M.E.
2009 *Caṇḍi Mendut: Womb of the Tathāgata*. New Delhi: Aditya Prakashan.
- Lutgendorf, P.
1997 'Monkey in the middle: The status of Hanuman in popular Hinduism', *Religion* 27:311-32.
- Malandra, Geri H.
1993 *Unfolding a maṇḍala: The Buddhist cave temples at Ellora*. Albany, NY: State University of New York Press. [SUNY Series in Buddhist Studies.]
- Mallmann, M.-Th. de
1963 *Les renseignements iconographiques de l'Agni-Purāṇa*. Paris: Presses Universitaires de France.
- Mevissen, Gerd J.R.
2009 'Dikpālas and Grahas at Paharpur in context of contemporaneous Pan-Indian temple imagery', in: Gerd J.R. Mevissen and Arundhati Banerji (eds), *Prajñādhara: Essays on Asian art, history, epigraphy and culture in honour of Gouriswar Bhattacharya*, pp. 393-406. New Delhi: Kaveri Books.
- Moertjijpto and Bambang Prasetyo
1994 *Mengenal Candi Siwa Prambanan dari dekat*. Yogyakarta: Kanisius.
- Mollien, É.
1853 *Recherches sur le Zodiaque indien*. Paris: Institut de France.
- Monier-Williams, M.
1899 *Sanskrit-English dictionary*. Oxford: Clarendon Press.
- Naerssen, F.H. van
1937 'Twee koperen oorkonden van Balitung in het Koloniaal Instituut te Amsterdam', *Bijdragen tot de Taal-, Land- en Volkenkunde* 95:441-61.
- Pott, P.H.
1966 *Yoga and Yantra: Their interrelation and their significance for Indian archaeology*. Translated from the Dutch by Rodney Needham. The Hague: Nijhoff. [KITLV, Translation Series 8.] [Originally published as *Yoga en Yantra in hunne betekenis voor de Indische archaeologie*. Leiden: Brill, 1946.]
- Rao, T.A. Gopinatha
1916 *Elements of Hindu iconography*. Vol. 2. Madras: Law Printing House.
- Reichle, Natasha
2007 *Violence and serenity: Late Buddhist sculpture from Indonesia*. Honolulu: University of Hawai'i Press.
- Robson, S.O.
2008 *Arjunawiwāha: The marriage of Arjuna of Mpu Kanwa*. Leiden: KITLV Press. [Bibliotheca Indonesica 34.]
- Sarkar, Himansu Bhusan
1971 *Corpus of the inscriptions of Java (Corpus inscriptionum Javanicarum) up to 928 A.D.* Calcutta: Mukhopadhyay. Three vols.
- Setianingsih, R.M.
1995 'Lempengan Emas Bertulis dari Candi B: Suaka Peninggalan Sejarah Purbakala', in: H. Santiko et al. (eds), *Kirana: Persembahan untuk Prof. Dr. Haryati Soebadio*, pp. 160-9. Jakarta: Intermedia (Fakultas Sastra Universitas Indonesia).
1998 'Dua batu berhias dari ruas sungai Opak: Data tambahan pembangunan percandian Prambanan', *Berkala Arkeologi* 18:17-29.

- Ślączka, A.A.
2007 *Temple consecration rituals in ancient India: Text and archaeology*. Leiden: Brill.
- Soekmono, R.
1995 *The Javanese candi: Function and meaning*. Leiden/New York/Köln: Brill.
- Stephen, M.
2005 *Desire, divine and demonic: Balinese mysticism in the paintings of I Ketut Budiana and I Gusti Nyoman Mirdiana*. Honolulu: University of Hawai'i Press.
- Sudarshana Devi
1957 *Wṛhaspati-tattwa: An Old Javanese philosophical text*. Nagpur: International Academy of Indian Culture.
1962 *Tattwajñāna and Mahajñāna*. New Delhi: International Academy of Indian Culture.
- Tan, R.
1967 'The domestic architecture of South Bali', *Bijdragen tot de Taal-, Land- en Volkenkunde* 123:442-75.
- Teeuw, A. and S.O. Robson
1981 *Kuñjarakarna Dharmakathana: Liberation through the law of the Buddha: An Old Javanese poem by Mpu Dusun*. With a contribution on the reliefs of Caṅḍi Jago by A.J. Bernet Kempers. The Hague: Nijhoff. [Bibliotheca Indonesica 21.]
- Tonnet, M.
1908 'De godenbeelden aan den buitenmuur van den Çiwa-tempel te Tjandi Prambanan en de vermoedelijke leeftijd van die tempelgroep', *Bijdragen tot de Taal-, Land- en Volkenkunde* 60:128-49.
- Vickers, Adrian
2011 'The Old Javanese Kapiparwa and a recent Balinese painting', in: Andrea Acri, Helen Creese and Arlo Griffiths (eds), *From Lañkā eastwards: The Rāmāyaṇa in the literature and visual arts of Indonesia*, pp. 119-30. Leiden: KITLV Press. [Verhandelingen 247.]
- Wessels-Mevissen, C.
2001 *The gods of the directions in ancient India: Origin and early development in art and literature (until c. 1000 A.D.)*. Berlin: Reimer.
- Wilkins, W.J.
1913 *Hindu mythology, Vedic and Purānic*. Third impression. Calcutta: Thacker, Spink. London: Thacker. [First edition 1882.]
- Zieseniss, A.
1939 'Studien zur Geschichte des Śivaismus: Die śivaitischen Systeme in der altjavanischen Literatur I', *Bijdragen tot de Taal-, Land- en Volkenkunde* 98:75-223.
- Zoetmulder, P.J.
1982 *Old Javanese-English dictionary*. With the collaboration of S.O. Robson. 's-Gravenhage: Nijhoff. Two vols. [KITLV.]



Panel D1, Plate XXXV (photo Kassian Cephass, Leiden University Library, Kern Institute, P-044553)



Panel D2, Plate XXXVI (photo Kassian Cephass, Leiden University Library, Kern Institute, P-044554)



Panel D3, Plate XXXVII (photo Kassian Cephas, Leiden University Library, Kem Institute, P-044555)



Panel D4, Plate XXXVIII (photo Kassian Cephas, Leiden University Library, Kern Institute, P-044556)



Panel D5, Plate XXXIX (photo Kassian Cephas, Leiden University Library, Kern Institute, P-044557)



Panel D6, Plate XL (photo Kassian Cephas, Leiden University Library, Kern Institute, P-044558)



Panel D7, Plate XLI (photo Kassian Cephas, Leiden University Library, Kern Institute, P-044559)



Panel D8, Plate XLII (photo Kassian Cephas, Leiden University Library, Kern Institute, P-044560)



Panel D9, Plate XLIII (photo Kassian Cephissos, Leiden University Library, Kern Institute, P-044561)



Panel D10, Plate XLIV (photo Kassian Cephas, Leiden University Library, Kern Institute, P-044562)



Panel D11, Plate XLV (photo Kassian Cephas, Leiden University Library, Kern Institute, P-044563)



Panel D12, Plate XLVI (photo Kassian Cephias, Leiden University Library, Kern Institute, P-044565)



Panel D13, Plate XLVII (photo Kassian Cephas, Leiden University Library, Kern Institute, P-044564)



Panel D14, Plate XLVIII (photo Kassian Cephas, Leiden University Library, Kern Institute, P-044566)



Panel D15, Plate XLIX (photo Kassian Cephas, Leiden University Library, Kern Institute, P-044567)



Panel D16, Plate L (photo Kassian Cephas, Leiden University Library, Kern Institute, P-044568)



Panel D17, Plate LI (photo Kassian Cephas, Leiden University Library, Kern Institute, P-044569)



Panel D18, Plate LII (photo Kassian Cephass, Leiden University Library, Kern Institute, P-044570)



Panel D19, Plate LIII (photo Kassian Cephas, Leiden University Library, Kern Institute, P-044571)



Panel D20, Plate LIV (photo Kassian Cephas, Leiden University Library, Kern Institute, P-044572)



Panel D21, Plate LV (photo Kassian Cephas, Leiden University Library, Kern Institute, P-044573)



Panel D22, Plate LVI (photo Kassian Cephas, Leiden University Library, Kern Institute, P-044574)



Panel D23, Plate LVII (photo Kassian Cephais, Leiden University Library, Kem Institute, P-044575)



Panel D24, Plate LVIII (photo Kassian Cephas, Leiden University Library, Kern Institute, P-044576)