



HAL
open science

Analytical modeling and design of high temperature superconducting machine

Thierry Lubin

► **To cite this version:**

Thierry Lubin. Analytical modeling and design of high temperature superconducting machine. École thématique. HTS Motors School, Nancy, France. 2020. hal-03015447

HAL Id: hal-03015447

<https://hal.science/hal-03015447v1>

Submitted on 19 Nov 2020

HAL is a multi-disciplinary open access archive for the deposit and dissemination of scientific research documents, whether they are published or not. The documents may come from teaching and research institutions in France or abroad, or from public or private research centers.

L'archive ouverte pluridisciplinaire **HAL**, est destinée au dépôt et à la diffusion de documents scientifiques de niveau recherche, publiés ou non, émanant des établissements d'enseignement et de recherche français ou étrangers, des laboratoires publics ou privés.

ANALYTICAL MODELING AND DESIGN OF HTS MACHINES

Thierry Lubin

Research Group in Electrical Engineering (GREEN), Nancy, France

Email: thierry.lubin@univ-lorraine.fr

High Temperature Superconducting Motor School

August 31 – September 4, 2020, Nancy, France

Presentation Outline

- ❑ **Speaker Biography (short)**
- ❑ **Topology of the studied HTS machine**
- ❑ **2D (Semi)-Analytical Model : assumptions, equations, solution...and discussion**
- ❑ **Back EMF and Torque computation**
- ❑ **Results: Matlab Programm, comparison with FEM**
- ❑ **Multi-Objective Design Optimization with GA:
P = 3 MW, N = 3000 rpm, PTM > 20 kW/Kg
(Electrical aircraft application, or other...)**

Discussions and questions during the presentation

Speaker Biography



1994: Msc. in electrical engineering, Paris 6, France + “agrégation” in applied physical sciences (to teach in high school),

2003: Ph.D. degree in electrical engineering, Nancy, France.

“Modeling and control of a Synchronous Reluctance Machine with magnetic saturation effects”

2016: HDR (Habilitation) degree in electrical engineering, Nancy, France (confers the right to be sole advisor of a PhD student).

“Contribution to the analytical modeling of electromagnetic actuators”

Since 2007 : Associate Professor in electrical engineering at Nancy

Before 2007: High school teacher

Teaching topics (Master degree):

- ◆ Electrical machines: modeling, design and control.
- ◆ AC electrical power network: modeling, power quality, protection.
- ◆ High power wind turbine: electrical part (machine, power electronics, control).

Research topics:

- ◆ 2D and 3D analytical modeling of electrical machines for their design
- ◆ Contactless torque transmissions by magnetic gears and couplers
- ◆ Applied superconductivity in electrical engineering

Author and co-author of more than 100 research papers in peer-reviewed journals and international conferences : <https://cv.archives-ouvertes.fr/thierry-lubin>

Why studied HTS machines?

For high power electrical machines (MW)
→ Lightweight and better efficiency



**Off-Shore Wind turbine
EcoSwing Project (2019)
3.6MW ; 15 rpm
(- 40% weight compare to
conventional system)**

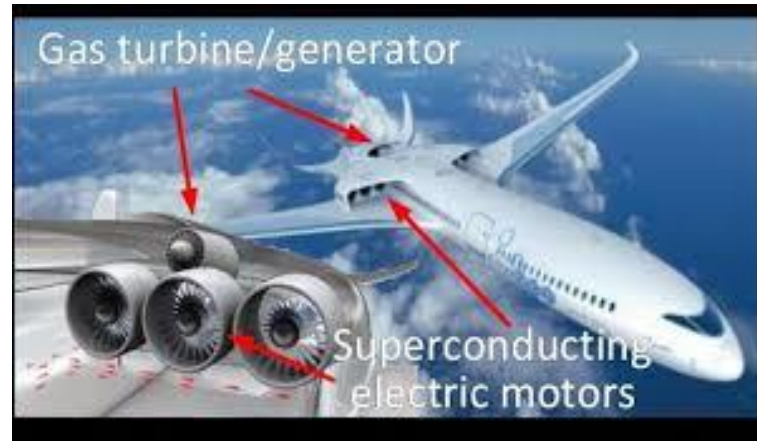

**More Electrical Aircraft
Motor propulsion
1-5 MW ; 3000-6000 rpm
Power to Mass ratio > 20 kW/kg
Impossible with conventional
technology (5 kW/Kg, PMs, copper)**

Topology of the studied HTS machine

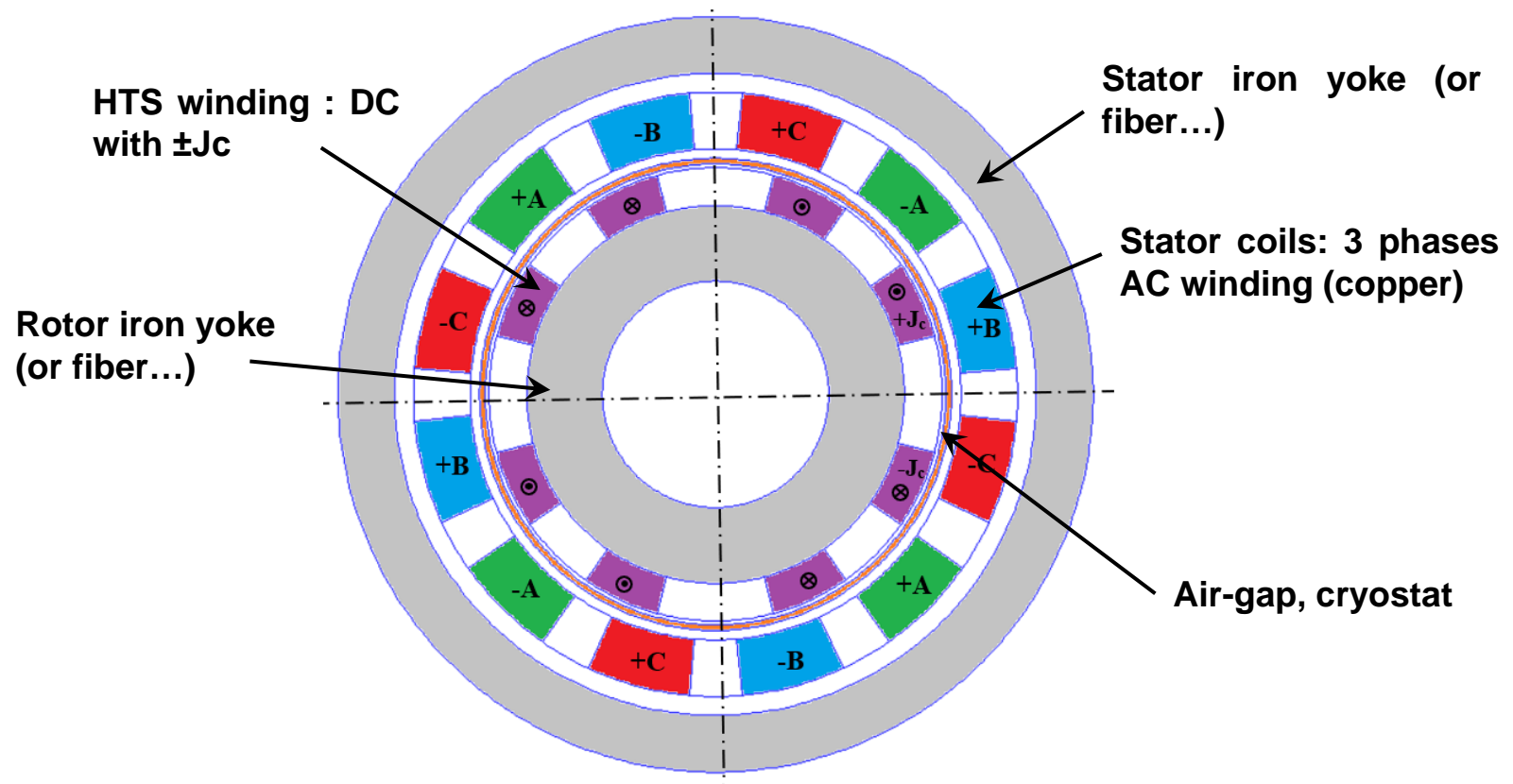

- ◆ Superconducting Synchronous Radial flux machine (axial flux is possible but more complicated to model due to the 3D effect....)
- ◆ Slotless machine: inductor with HTS winding (not possible with copper due to the Joule losses, sometimes with PM...)
- ◆ Rotor HTS winding or bulk: $\pm J_c$ with $J_c = 200 \text{ A/mm}^2$ at 20-30K (more complex model next days, the cooling is not studied here)
- ◆ Three phase stator AC winding: $J_{s_{\text{rms}}} = 20 \text{ A/mm}^2$ (possible with water or oil forced cooling, look at electrical vehicle for example, Litz wire to reduce AC losses)

HTS wires : $J_c(B,T)$ characteristics

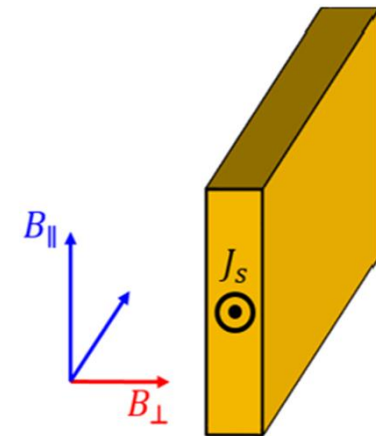
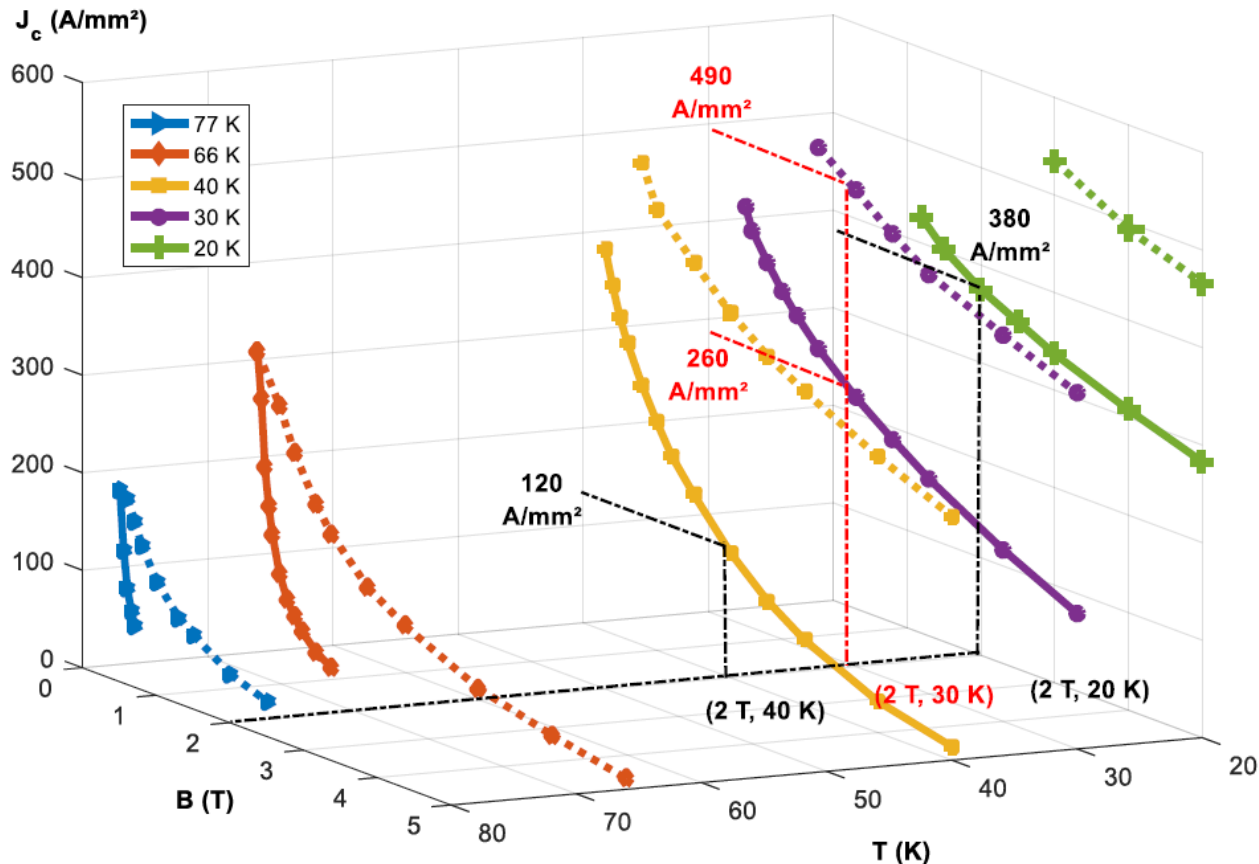

◆ $J_c = 200 \text{ A/mm}^2$ at 30K is correct but this should be include in the design procedure (not done here)... Perhaps the maximal constraint is on the end-winding (3D model.....)

What we want to obtain « by hand »!

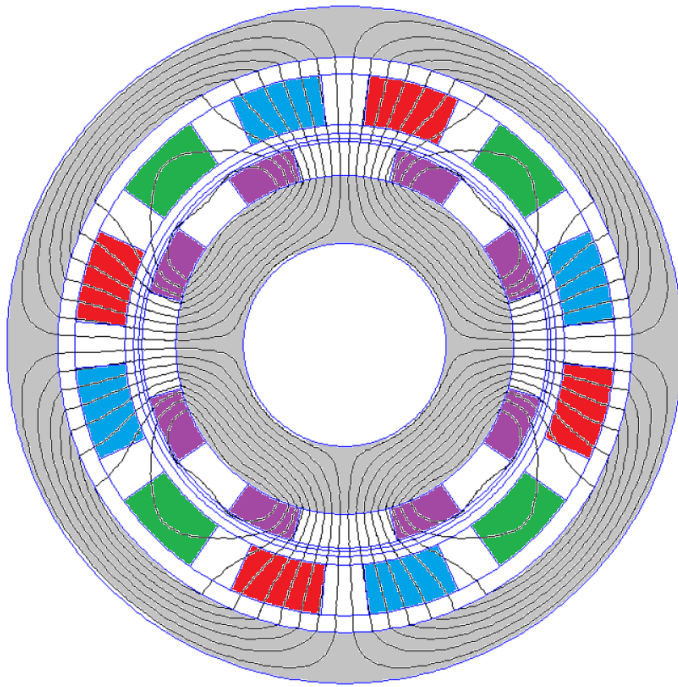

No-load: back EMF computation

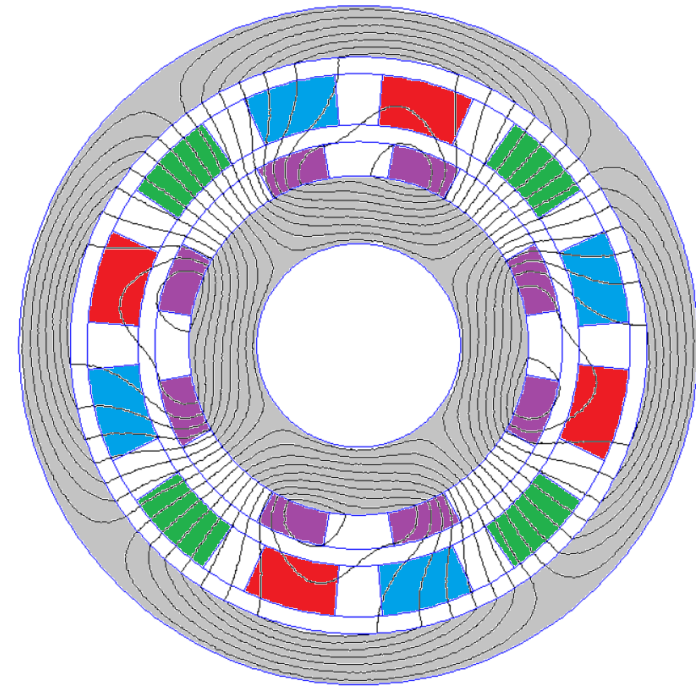

Full-load (90°): Torque computation

**A very fast and accurate model is needed if we want to use it with an optimization procedure : Analytical model
First step design (cooling, ac losses....)!**

We will consider all the source terms (rotor and stator) in the analytical model but this is not mandatory, it depends on what we want to study!

- The torque can be computed by the Laplace force by only knowing the rotor magnetic field distribution.
- But if we want to know the armature reaction (harmonic terms) on the HTS winding (AC losses computation...), we have to compute it!

Physical and Geometrical parameters

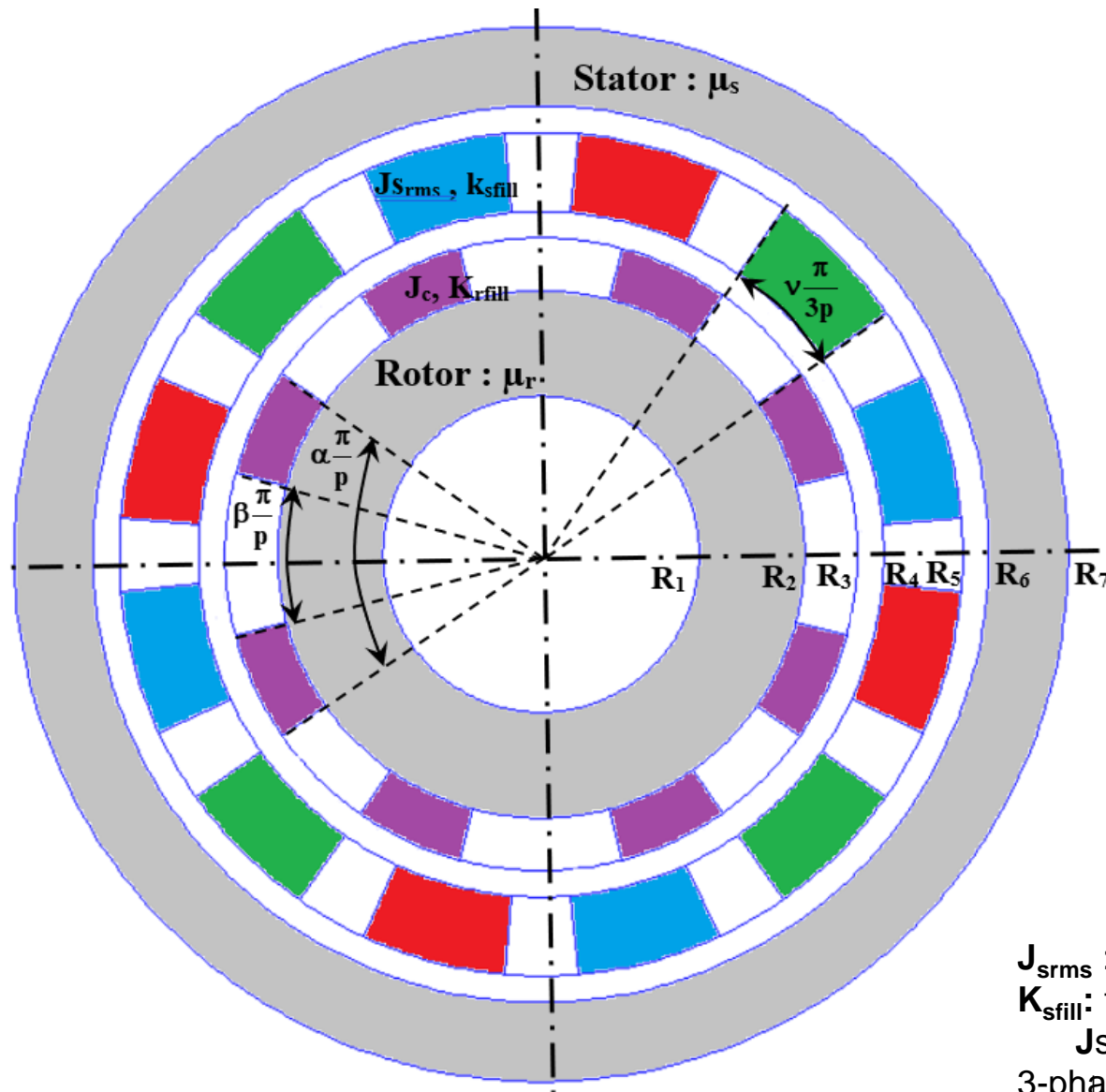

p : pole-pairs number

L : axial length

R_1 : inner radius of the rotor

$a = R_2 - R_1$: thickness rotor yoke

$b = R_3 - R_2$: thickness HTS winding

$c = R_4 - R_3$: air-gap thickness

$d = R_5 - R_4$: thickness stator winding

$e = R_6 - R_5$: 2nd air-gap thickness

$f = R_7 - R_6$: thickness stator yoke

α : outer opening of HTS coils

β : inner opening of the HTS coils

v : opening of the stator coils

$$0 < \alpha; \beta; v < 1$$

μ_s : stator yoke relative permeability

μ_r : rotor yoke relative permeability

J_c : critical current of the HTS coils

K_{rfill} : fill factor HTS coils

$$J_c = 200 \text{ A/mm}^2; K_{rfill} = 0,7$$

J_{srms} : stator RMS current density

K_{sfill} : fill factor stator coils

$$J_{srms} = 20 \text{ A/mm}^2; K_{sfill} = 0,5$$

3-phase distributed stator winding

Model and Assumptions

8 homogeneous cylindrical regions with periodicity of $2\pi/p$

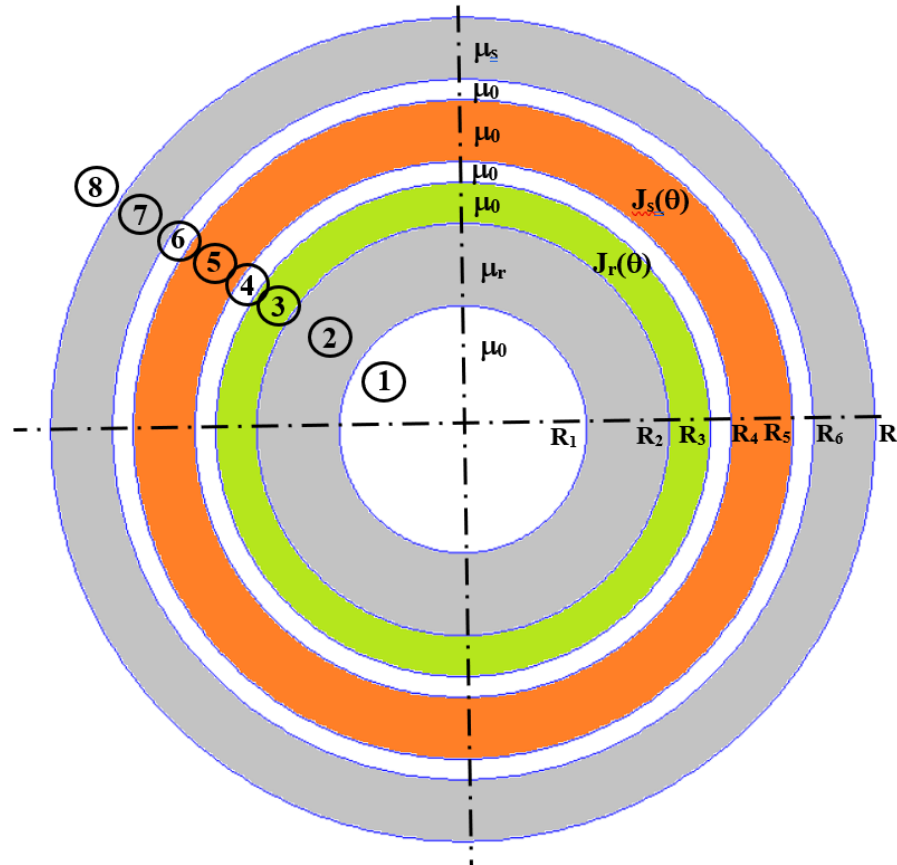

- Perfect cylindrical geometry: cylindrical coordinates (r, θ)
- End-effects are neglected: 2D analytical model
- Constant permeability for the iron parts: magnetic saturation is not taken into account (be careful that $B < 2T$ in the iron for the simulation!!)
- Current in the coils is imposed (stator and rotor): equivalent current density distribution $J_s(\theta)$ and $J_r(\theta)$

2D field problem in cylindrical coordinates

- ◆ Current density $\mathbf{J} = (0, 0, J_z)$
- ◆ Vector magnetic potential $\mathbf{A} = (0, 0, A_z)$
- ◆ Magnetic field strength $\mathbf{H} = (H_r, H_\theta, 0)$
- ◆ Flux density $\mathbf{B} = (B_r, B_\theta, 0)$

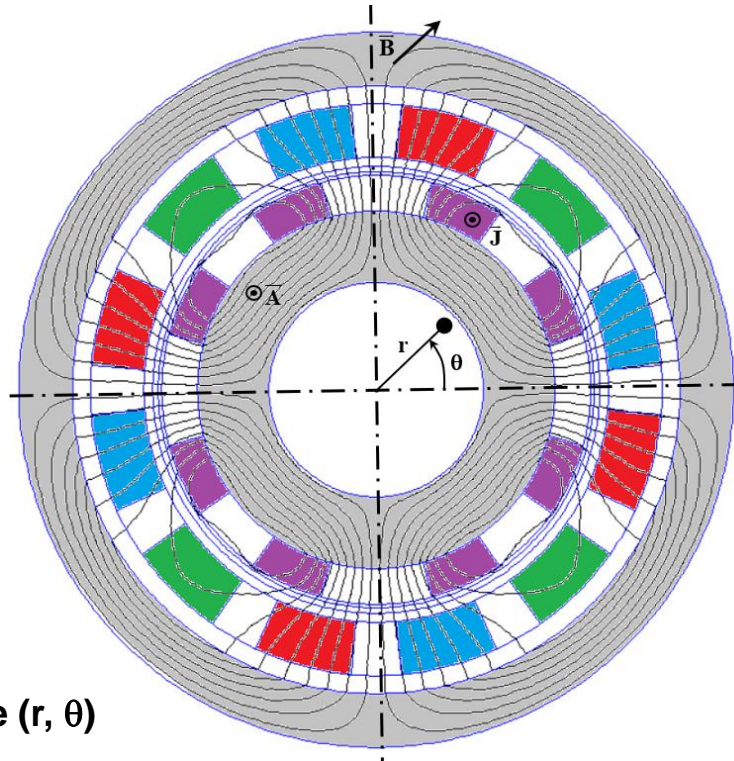

Motor section in the plane (r, θ)

Maxwell's equations and Boundary conditions at radius R_i

$$\begin{aligned} \nabla \times \mathbf{H} &= \mathbf{J} \\ \nabla \cdot \mathbf{B} &= \mathbf{0} \end{aligned} \quad \text{with} \quad \begin{aligned} \mathbf{B} &= \mu_0 \mu_r \mathbf{H} \quad (\text{linear and no magnet}) \\ \mathbf{J} &: \text{current density in the coils} \end{aligned}$$

Magnetic vector potential formulation : $\mathbf{A} = A_z(r, \theta) \mathbf{u}_z$

$$\nabla \cdot \mathbf{B} = \mathbf{0} \rightarrow \mathbf{B} = \nabla \times \mathbf{A} \quad \text{with} \quad \nabla \cdot \mathbf{A} = \mathbf{0}$$

$$\Delta A = -\mu_0 \mathbf{J} \quad (\text{regions 3 and 5})$$

$$\Delta A = \mathbf{0} \quad (\text{for the other regions})$$

- ◆ Continuity of the normal component of the flux density:

$$B_{r_i}(R_i, \theta) = B_{r_{i+1}}(R_i, \theta) \rightarrow A_i(R_i, \theta) = A_{i+1}(R_i, \theta)$$

- ◆ Continuity of the tangential component of the magnetic field:

$$H_{\theta_i}(R_i, \theta) = H_{\theta_{i+1}}(R_i, \theta) \rightarrow \frac{1}{\mu_i} \left. \frac{\partial A_i}{\partial r} \right|_{R_i} = \frac{1}{\mu_{i+1}} \left. \frac{\partial A_{i+1}}{\partial r} \right|_{R_i}$$

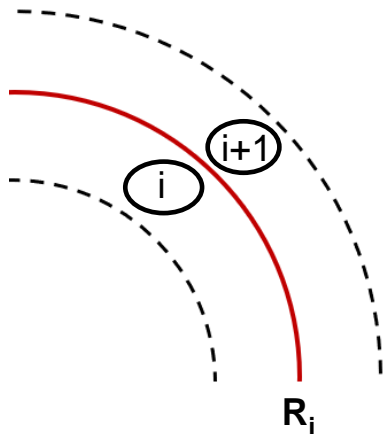

Partial Differential Equations to solve

$$\frac{\partial^2 A_3}{\partial r^2} + \frac{1}{r} \frac{\partial A_3}{\partial r} + \frac{1}{r^2} \frac{\partial^2 A_3}{\partial \theta^2} = -\mu_0 J_r(\theta) \quad \text{for region 3 (HTS windings)}$$

$$\frac{\partial^2 A_5}{\partial r^2} + \frac{1}{r} \frac{\partial A_5}{\partial r} + \frac{1}{r^2} \frac{\partial^2 A_5}{\partial \theta^2} = -\mu_0 J_s(\theta) \quad \text{for region 5 (stator windings)}$$

$$\frac{\partial^2 A_i}{\partial r^2} + \frac{1}{r} \frac{\partial A_i}{\partial r} + \frac{1}{r^2} \frac{\partial^2 A_i}{\partial \theta^2} = 0 \quad \text{for other regions (i = 1, 2, 4, 6, 7 and 8)}$$

◆ Source terms: Stator and rotor current density distribution

$$J_r(\theta) = \sum_{n=1,3,5\dots}^N J_m \sin(np(\theta + \delta)) \quad J_s(\theta) = \sum_{n=1,3,5\dots}^N J_{sn} \sin(np\theta)$$

With J_m and J_{sn} to be determinate (next slides), δ is the load angle attached to the rotor

◆ Periodic problem with a period equal to $2\pi/p$, the solution in each region can be write as

$$A_i(r, \theta) = \sum_{n=1,3,5\dots}^N A_{in}(r) \sin(np(\theta + \alpha))$$

Complex notation (more compact)

$$A_i(r, \theta) = \sum_{n=1,3,5\dots}^N A_{in}(r) \sin(np(\theta + \alpha)) \quad \rightarrow \quad A_i(r, \theta) = \text{Im} \left(\sum_{n=1,3,5\dots}^N \underline{A}_{in}(r) e^{jnp\theta} \right)$$

The PDE (region 3) becomes an ODE complex equation (Euler):

$$\frac{\partial^2 A_3}{\partial r^2} + \frac{1}{r} \frac{\partial A_3}{\partial r} + \frac{1}{r^2} \frac{\partial^2 A_3}{\partial \theta^2} = -\mu_0 J_r(\theta) \quad \rightarrow \quad r^2 \frac{d^2 \underline{A}_{3n}}{dr^2} + r \frac{d \underline{A}_{3n}}{dr} - (np)^2 \underline{A}_{3n} = -\mu_0 r^2 \underline{J}_m$$

Solution of the Euler equation:

$$\underline{A}_{3n}(r) = \underline{K}_1 r^{np} + \underline{K}_2 r^{-np} + \underline{A}_p(r)$$

Where \underline{K}_1 and \underline{K}_2 are the integration constants that will be computed from the interface conditions and $\underline{A}_p(r)$ is the particular solution :

$$\underline{A}_p(r) = \begin{cases} \mu_0 \frac{r^2}{(np)^2 - 4} \underline{J}_m & \text{for } np \neq 2 \\ \frac{1}{16} \mu_0 r^2 (1 - 4 \ln r) \underline{J}_m & \text{for } np = 2 \end{cases}$$

Solution in the different regions

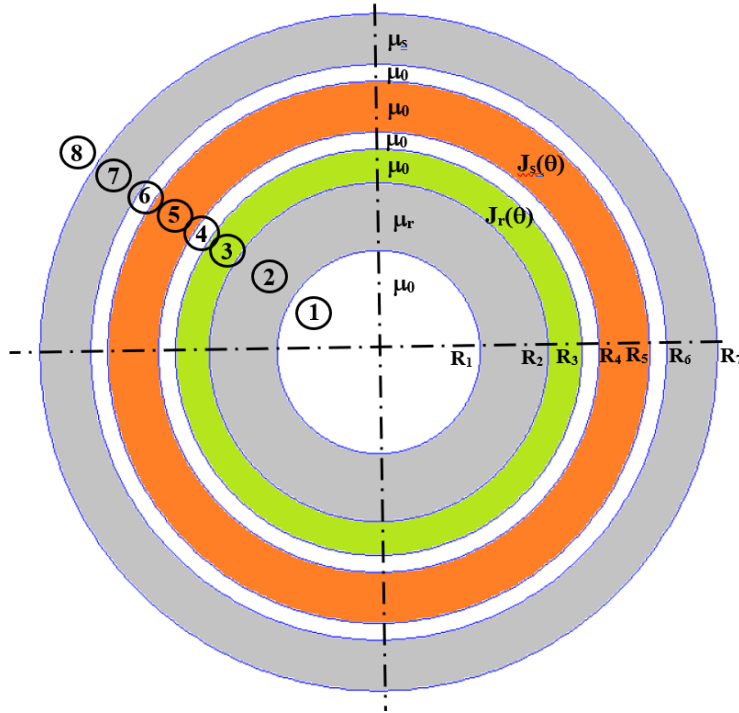

$$\underline{A}_{1n}(r) = \underline{K}_1 r^{np}$$

$$\underline{A}_{2n}(r) = \underline{K}_2 r^{np} + \underline{K}_3 r^{-np}$$

$$\underline{A}_{3n}(r) = \underline{K}_4 r^{np} + \underline{K}_5 r^{-np} + \underline{A}_{p3}(r)$$

$$\underline{A}_{4n}(r) = \underline{K}_6 r^{np} + \underline{K}_7 r^{-np}$$

$$\underline{A}_{5n}(r) = \underline{K}_8 r^{np} + \underline{K}_9 r^{-np} + \underline{A}_{p5}(r)$$

$$\underline{A}_{6n}(r) = \underline{K}_{10} r^{np} + \underline{K}_{11} r^{-np}$$

$$\underline{A}_{7n}(r) = \underline{K}_{12} r^{np} + \underline{K}_{13} r^{-np}$$

$$\underline{A}_{8n}(r) = \underline{K}_{14} r^{-np}$$

$$\underline{A}_{p3}(r) = \begin{cases} \mu_0 \frac{r^2}{(np)^2 - 4} \underline{J}_{-m} & \text{for } np \neq 2 \\ \frac{1}{16} \mu_0 r^2 (1 - 4 \ln r) \underline{J}_{-m} & \text{for } np = 2 \end{cases}$$

$$\underline{A}_{p5}(r) = \begin{cases} \mu_0 \frac{r^2}{(np)^2 - 4} \underline{J}_{-sn} & \text{for } np \neq 2 \\ \frac{1}{16} \mu_0 r^2 (1 - 4 \ln r) \underline{J}_{-sn} & \text{for } np = 2 \end{cases}$$

We have 14 coefficients to determine (\underline{K}_1 to \underline{K}_{14}) from the interface conditions; Expression of \underline{J}_{-m} and \underline{J}_{-sn} to be determinate

Relations between the unknown coefficients (1/3)

Relations at the interface between 2 regions:

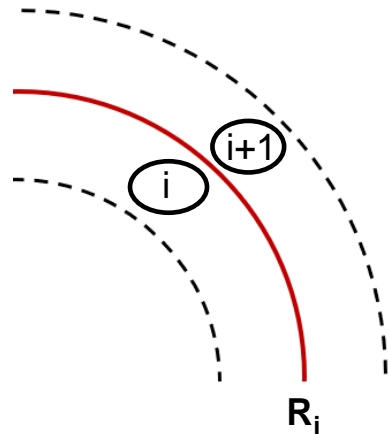

$$\begin{cases} \underline{A}_{in}(R_i) = \underline{A}_{(i+1)n}(R_i) \\ \frac{1}{\mu_i} \left. \frac{\partial \underline{A}_{in}}{\partial r} \right|_{R_i} = \frac{1}{\mu_{i+1}} \left. \frac{\partial \underline{A}_{(i+1)n}}{\partial r} \right|_{R_i} \end{cases}$$

We have 7 interfaces (R_1 to R_7) with 2 relations by interface that corresponds to 14 equations

It's up to you!

Determine the 14 relations between the coefficients and write them in matrix form.

Relations between the unknown coefficients (2/3)

$$r = R_1 \rightarrow \begin{cases} \underline{K}_1 R_1^{np} = \underline{K}_2 R_1^{np} + \underline{K}_3 R_1^{-np} \\ \underline{K}_1 R_1^{np-1} = \frac{1}{\mu_r} (\underline{K}_2 R_1^{np-1} - \underline{K}_3 R_1^{-np-1}) \end{cases}$$

$$r = R_2 \rightarrow \begin{cases} \underline{K}_2 R_2^{np} + \underline{K}_3 R_2^{-np} = \underline{K}_4 R_2^{np} + \underline{K}_5 R_2^{-np} + \mu_0 \frac{R_2^2}{(np)^2 - 4} \underline{J}_{-m} \\ \frac{1}{\mu_r} (\underline{K}_2 R_2^{np-1} - \underline{K}_3 R_2^{-np-1}) = \underline{K}_4 R_2^{np-1} - \underline{K}_5 R_2^{-np-1} + 2\mu_0 \frac{R_2}{np((np)^2 - 4)} \underline{J}_{-m} \end{cases}$$

$$r = R_2 \rightarrow \begin{cases} \underline{K}_4 R_3^{np} + \underline{K}_5 R_3^{-np} + \mu_0 \frac{R_3^2}{(np)^2 - 4} \underline{J}_{-m} = \underline{K}_6 R_3^{np} + \underline{K}_7 R_3^{-np} \\ \underline{K}_4 R_3^{np-1} - \underline{K}_5 R_3^{-np-1} + 2\mu_0 \frac{R_3}{np((np)^2 - 4)} \underline{J}_{-m} = \underline{K}_6 R_3^{np-1} - \underline{K}_7 R_3^{-np-1} \end{cases}$$

$$r = R_4 \rightarrow \begin{cases} \underline{K}_6 R_4^{np} + \underline{K}_7 R_4^{-np} = \underline{K}_8 R_4^{np} + \underline{K}_9 R_4^{-np} + \mu_0 \frac{R_4^2}{(np)^2 - 4} \underline{J}_{-sn} \\ \underline{K}_6 R_4^{np-1} - \underline{K}_7 R_4^{-np-1} = \underline{K}_8 R_4^{np-1} - \underline{K}_9 R_4^{-np-1} + 2\mu_0 \frac{R_4}{np((np)^2 - 4)} \underline{J}_{-sn} \end{cases}$$

Relations between the unknown coefficients (3/3)

$$\begin{aligned}
 r = R_5 &\rightarrow \begin{cases} \underline{K}_8 R_5^{np} + \underline{K}_9 R_5^{-np} + \mu_0 \frac{R_5^2}{(np)^2 - 4} \underline{J}_{sn} = \underline{K}_{10} R_5^{np} + \underline{K}_{11} R_5^{-np} \\ \underline{K}_8 R_5^{np-1} - \underline{K}_9 R_5^{-np-1} + 2\mu_0 \frac{R_5}{np((np)^2 - 4)} \underline{J}_{sn} = \underline{K}_{10} R_5^{np-1} - \underline{K}_{11} R_5^{-np-1} \end{cases} \\
 r = R_6 &\rightarrow \begin{cases} \underline{K}_{10} R_6^{np} + \underline{K}_{11} R_6^{-np} = \underline{K}_{12} R_6^{np} + \underline{K}_{13} R_6^{-np} \\ \underline{K}_{10} R_6^{np-1} - \underline{K}_{11} R_6^{-np-1} = \frac{1}{\mu_s} (\underline{K}_{12} R_6^{np-1} - \underline{K}_{13} R_6^{-np-1}) \end{cases} \\
 r = R_7 &\rightarrow \begin{cases} \underline{K}_{12} R_7^{np} + \underline{K}_{13} R_7^{-np} = \underline{K}_{14} R_6^{-np} \\ \frac{1}{\mu_s} (\underline{K}_{12} R_7^{np-1} - \underline{K}_{13} R_7^{-np-1}) = -\underline{K}_{14} R_7^{-np-1} \end{cases}
 \end{aligned}$$

Valid for $np \neq 2$. For $np = 2$ (that corresponds only to the case $n = 1$ and $p = 2$), see the previous expression for the particular solution (slide 13).

In the previous relations, μ_s and μ_r are the relative permeability, $\mu_s = \mu_r = 1$ if regions 2 and 7 are made with no-magnetic material, that corresponds to a totally ironless machine!

Writing in Matrix form (Global matrix)

$$\begin{bmatrix}
 M_{11} & M_{11} & M_{11} & 0 & 0 & 0 & 0 & 0 & 0 & 0 & 0 & 0 & 0 & 0 \\
 M_{21} & M_{21} & M_{21} & 0 & 0 & 0 & 0 & 0 & 0 & 0 & 0 & 0 & 0 & 0 \\
 0 & M_{32} & M_{33} & M_{34} & M_{35} & 0 & 0 & 0 & 0 & 0 & 0 & 0 & 0 & 0 \\
 0 & M_{42} & M_{43} & M_{44} & M_{45} & 0 & 0 & 0 & 0 & 0 & 0 & 0 & 0 & 0 \\
 0 & 0 & 0 & M_{54} & M_{55} & M_{56} & M_{57} & 0 & 0 & 0 & 0 & 0 & 0 & 0 \\
 0 & 0 & 0 & M_{64} & M_{65} & M_{66} & M_{67} & 0 & 0 & 0 & 0 & 0 & 0 & 0 \\
 0 & 0 & 0 & 0 & 0 & M_{76} & M_{77} & M_{78} & M_{79} & 0 & 0 & 0 & 0 & 0 \\
 0 & 0 & 0 & 0 & 0 & M_{86} & M_{87} & M_{88} & M_{89} & 0 & 0 & 0 & 0 & 0 \\
 0 & 0 & 0 & 0 & 0 & 0 & 0 & M_{98} & M_{99} & M_{910} & M_{911} & 0 & 0 & 0 \\
 0 & 0 & 0 & 0 & 0 & 0 & 0 & M_{108} & M_{109} & M_{1010} & M_{1011} & 0 & 0 & 0 \\
 0 & 0 & 0 & 0 & 0 & 0 & 0 & 0 & 0 & M_{1110} & M_{1111} & M_{1112} & M_{1113} & 0 \\
 0 & 0 & 0 & 0 & 0 & 0 & 0 & 0 & 0 & M_{12} & M_{1211} & M_{1212} & M_{1213} & 0 \\
 0 & 0 & 0 & 0 & 0 & 0 & 0 & 0 & 0 & 0 & 0 & M_{1312} & M_{1313} & M_{1314} \\
 0 & 0 & 0 & 0 & 0 & 0 & 0 & 0 & 0 & 0 & 0 & M_{1412} & M_{1413} & M_{1414}
 \end{bmatrix}
 \times
 \begin{pmatrix}
 \underline{K}_1 \\
 \underline{K}_2 \\
 \underline{K}_3 \\
 \underline{K}_4 \\
 \underline{K}_5 \\
 \underline{K}_6 \\
 \underline{K}_7 \\
 \underline{K}_8 \\
 \underline{K}_9 \\
 \underline{K}_{10} \\
 \underline{K}_{11} \\
 \underline{K}_{12} \\
 \underline{K}_{13} \\
 \underline{K}_{14}
 \end{pmatrix}
 =
 \begin{pmatrix}
 0 \\
 0 \\
 \underline{S}_3 \\
 \underline{S}_4 \\
 \underline{S}_5 \\
 \underline{S}_6 \\
 \underline{S}_7 \\
 \underline{S}_8 \\
 \underline{S}_9 \\
 \underline{S}_{10} \\
 0 \\
 0 \\
 0 \\
 0
 \end{pmatrix}$$

Where M_{11}, M_{12}, \dots are sub-matrix (n-by-n matrix, diagonal, where n is number of harmonics considered)

$\underline{S}_3, \underline{S}_4, \dots$ are the source terms (vectors of length n)

The length of the global matrix (topological matrix) is 14n-by-14n

Sub-Matrix form

First line of the global matrix:

For 3 harmonics ($n = 1, 3, 5$) and $p = 4$

$$\begin{matrix}
 [M_{11}] & [M_{12}] & [M_{13}] \\
 \downarrow & \swarrow & \swarrow \\
 R_1^{np} K_1 & -R_1^{np} K_2 & -R_1^{-np} K_3 = 0
 \end{matrix}$$

$$[M_{11}] = \begin{bmatrix} R_1^4 & 0 & 0 \\ 0 & R_1^{12} & 0 \\ 0 & 0 & R_1^{20} \end{bmatrix} \quad [M_{13}] = - \begin{bmatrix} R_1^{-4} & 0 & 0 \\ 0 & R_1^{-12} & 0 \\ 0 & 0 & R_1^{-20} \end{bmatrix}$$

Third line of the global matrix:

$$\begin{matrix}
 [M_{31}] & [M_{32}] & [M_{33}] & [M_{34}] \\
 \uparrow & \uparrow & \swarrow & \swarrow \\
 R_2^{np} K_2 & +R_2^{-np} K_3 & -R_2^{np} K_4 & -R_2^{-np} K_5 = \mu_0 \frac{R_2^2}{(np)^2 - 4} J_{-m}
 \end{matrix}$$

$$(\underline{S}_3) = \begin{pmatrix} \frac{\mu_0 R_2^2}{12} J_{-r1} \\ \frac{\mu_0 R_2^2}{140} J_{-r3} \\ \frac{\mu_0 R_2^2}{396} J_{-r5} \end{pmatrix}$$

Important note : ill-conditioned global matrix and numerical problem

For example, if we consider $R_1 = 0,2$ m for 3 harmonics ($n = 1, 3, 5$) and $p = 4$

$$[M_{11}] = \begin{bmatrix} 1.10^{-3} & 0 & 0 \\ 0 & 4.10^{-9} & 0 \\ 0 & 0 & 1.10^{-14} \end{bmatrix} \quad [M_{13}] = - \begin{bmatrix} 625 & 0 & 0 \\ 0 & 2.10^8 & 0 \\ 0 & 0 & 9.10^{13} \end{bmatrix}$$

Very large numbers and very small numbers in the topological matrix: numerical problem of precision during the inversion: it is better to write the solution as dimensionless coefficients (radius ratio), but this is not dealt with here.....You can do it!

Matrix form : extract of the Matlab programm...

```

% Sub-matrix filling
for n = 1:nn
    k=(2*n-1)*p;

    M11(n,n)=R1^k;
    M12(n,n)=-(R1^k);
    M13(n,n)=-(R1^(-k));

    M21(n,n)=R1^(k-1);
    M22(n,n)=-(1/mur)*(R1^(k-1));
    M23(n,n)=(1/mur)*(R1^(-k-1));

    M32(n,n)=R2^k;
    M33(n,n)=R2^(-k);
    ...

% Global matrix filling

%
%           K1      ,      K2      ,      K3      ,      K4      ,      K5      ,      K6
G = [      M11      ,      M12      ,      M13      ,      zeros(nn,nn) ,      zeros(nn,nn) ,      zeros(
           M21      ,      M22      ,      M23      ,      zeros(nn,nn) ,      zeros(nn,nn) ,      zeros
           zeros(nn,nn) ,      M32      ,      M33      ,      M34      ,      M35      ,      zeros
           zeros(nn,nn) ,      M42      ,      M43      ,      M44      ,      M45      ,      zeros
           zeros(nn,nn) ,      zeros(nn,nn) ,      zeros(nn,nn) ,      M54      ,      M55      ,      M
           zeros(nn,nn) ,      zeros(nn,nn) ,      zeros(nn,nn) ,      M64      ,      M65      ,      M
           zeros(nn,nn) ,      zeros(nn,nn) ,      zeros(nn,nn) ,      zeros(nn,nn) ,      zeros(nn,nn) ,      |
           zeros(nn,nn) ,      zeros(nn,nn) ,      zeros(nn,nn) ,      zeros(nn,nn) ,      zeros(nn,nn) ,      |
           zeros(nn,nn) ,      zeros(nn,nn) ,      zeros(nn,nn) ,      zeros(nn,nn) ,      zeros(nn,nn) ,      zeros
           zeros(nn,nn) ,      zeros(nn,nn) ,      zeros(nn,nn) ,      zeros(nn,nn) ,      zeros(nn,nn) ,      zeros
           zeros(nn,nn) ,      zeros(nn,nn) ,      zeros(nn,nn) ,      zeros(nn,nn) ,      zeros(nn,nn) ,      zeros
           zeros(nn,nn) ,      zeros(nn,nn) ,      zeros(nn,nn) ,      zeros(nn,nn) ,      zeros(nn,nn) ,      zeros
           zeros(nn,nn) ,      zeros(nn,nn) ,      zeros(nn,nn) ,      zeros(nn,nn) ,      zeros(nn,nn) ,      zeros
           zeros(nn,nn) ,      zeros(nn,nn) ,      zeros(nn,nn) ,      zeros(nn,nn) ,      zeros(nn,nn) ,      zeros

% Source term vector
%
%           K1      ,      K2      ,      K3      ,      K4      ,      K5      ,      K6
S = [ zeros(nn,1) ;      zeros(nn,1) ;      S3      ;      S4      ;      S5      ;      S

% Matrix inversion

X = G\S;

```

Source terms : HTS current density $J_r(\theta)$

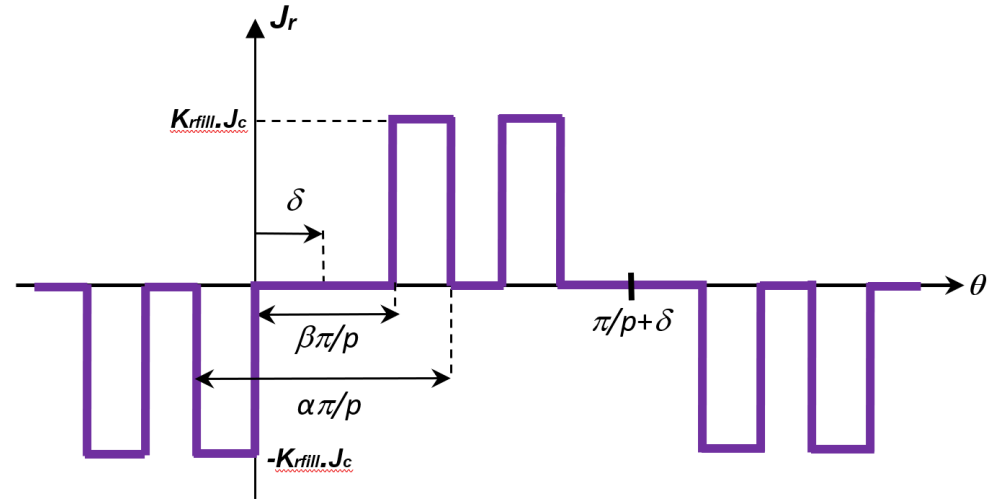
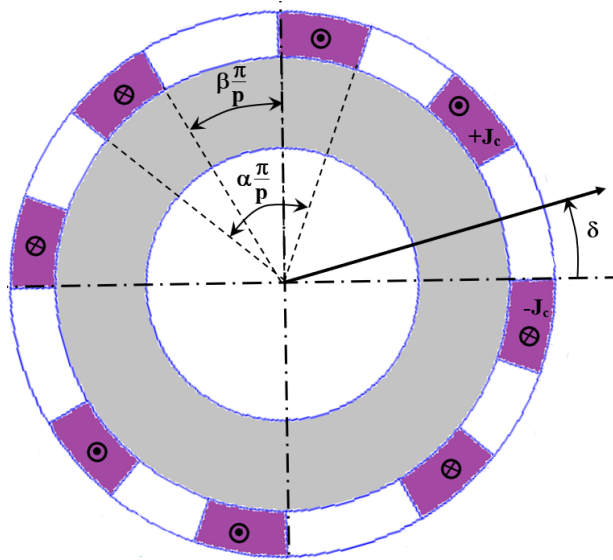

$$J_r(\theta) = \sum_{n=1,3,5,\dots}^N J_m \sin(np(\theta - \delta))$$

$$J_m = \frac{4K_{rfill}J_c}{n\pi} \left(\cos\left(n\beta\frac{\pi}{2}\right) - \cos\left(n\alpha\frac{\pi}{2}\right) \right)$$

- p : pole-pairs number
- α : outer opening of HTS coils
- β : inner opening of the HTS coils
- δ : rotor position (load torque)
- J_c : critical current of the HTS coils
- K_{rfill} : fill factor for the HTS coils
- $J_c = 300 \text{ A/mm}^2$; $K_{rfill} = 0,7$

In complex notation:

$$\underline{J}_m = J_m e^{-jnp\delta}$$

Source terms : HTS current density $J_r(\theta)$

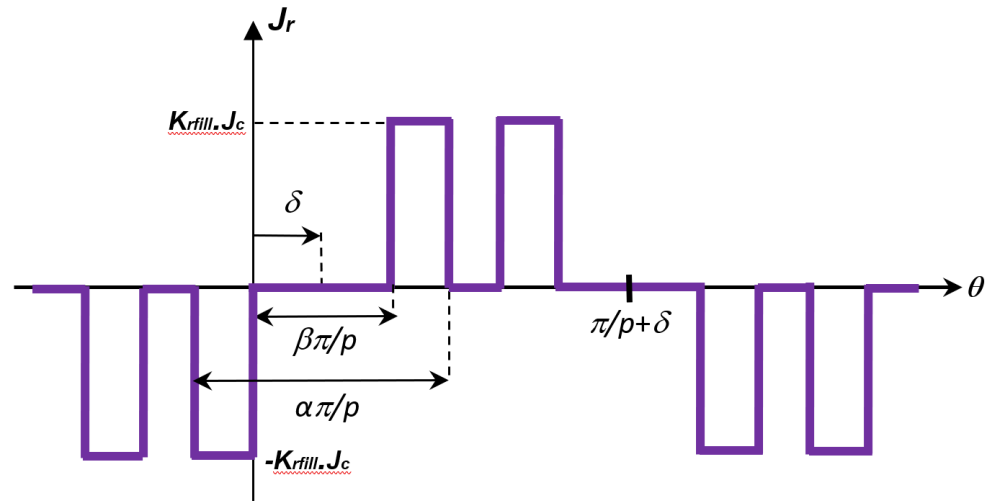
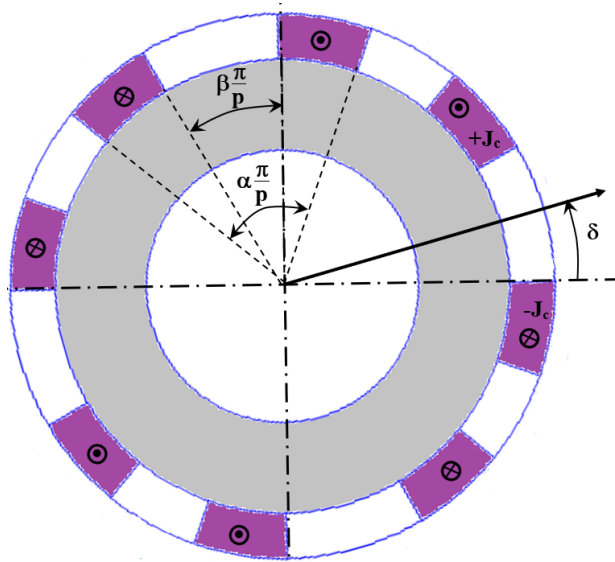

$$J_m = \frac{4K_{rfill}J_c}{n\pi} \left(\cos\left(n\beta\frac{\pi}{2}\right) - \cos\left(n\alpha\frac{\pi}{2}\right) \right)$$

$p = 2; \alpha = 0.9; \beta = 0.5$
 $J_c = 300 \text{ A/mm}^2; K_{rfill} = 0,7$

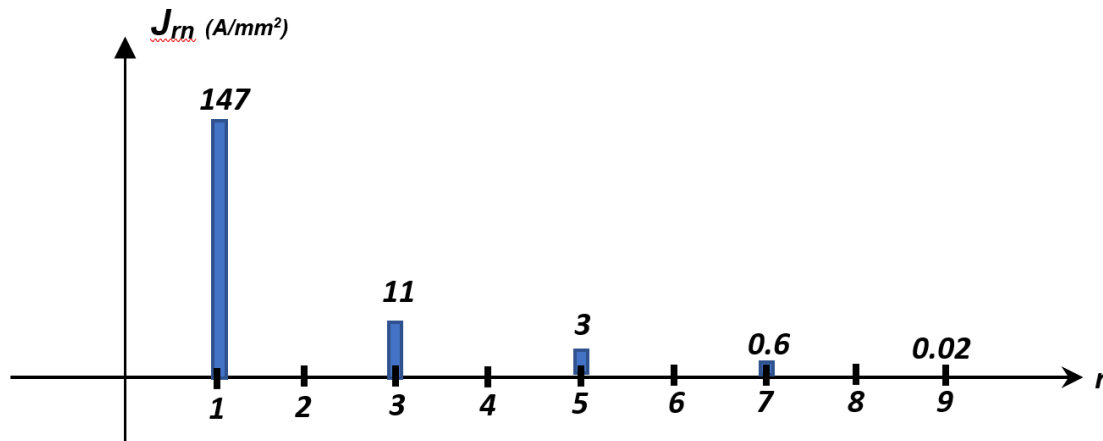

Source terms: three-phase AC winding $J_s(\theta)$

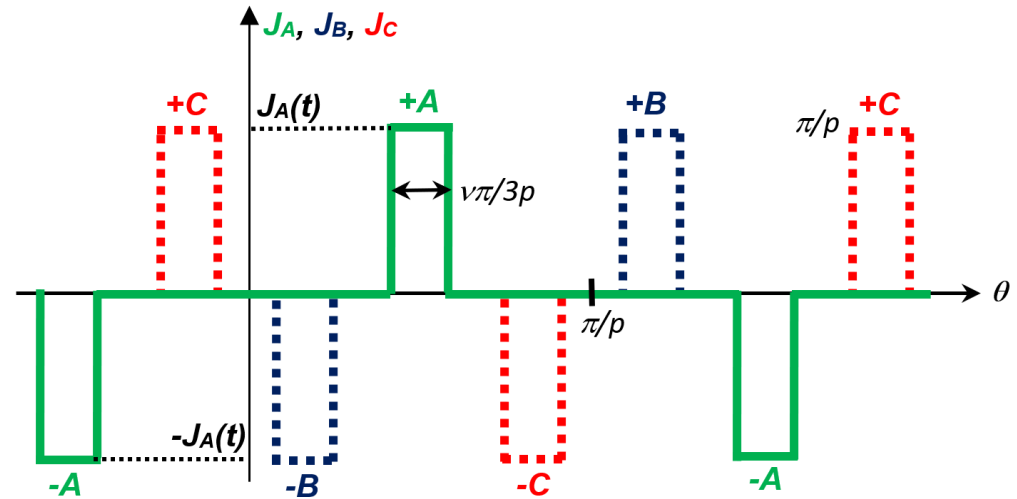
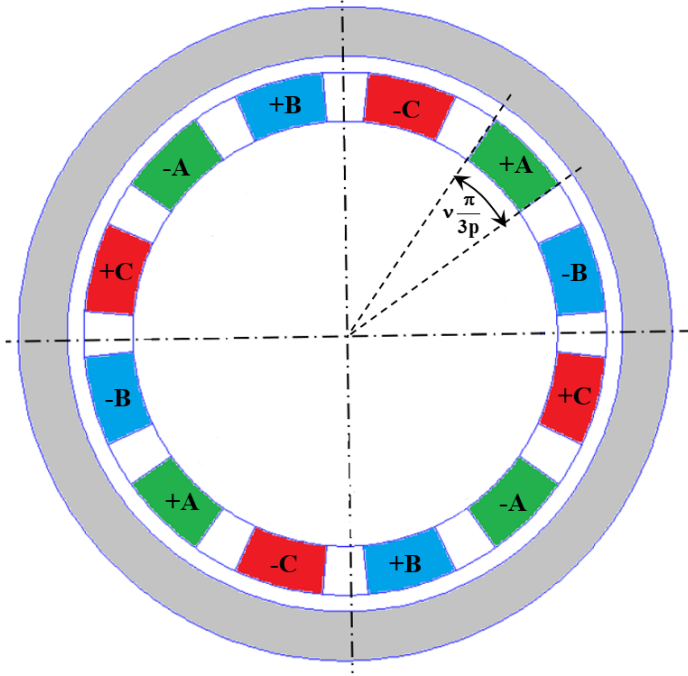

The 3 phases windings are fed by AC
3 phases current \rightarrow Rotating field

3-phase distributed stator winding

p : pole-pairs number

v : opening of the stator coils

J_{srms} : stator RMS current density

K_{sfill} : fill factor stator coils

$J_{srms} = 20 \text{ A/mm}^2$; $K_{sfill} = 0,5$

$$J_A(t) = K_{sfill} J_{srms} \sqrt{2} \cos(\omega t)$$

$$J_B(t) = K_{sfill} J_{srms} \sqrt{2} \cos(\omega t - 2\pi/3)$$

$$J_C(t) = K_{sfill} J_{srms} \sqrt{2} \cos(\omega t + 2\pi/3)$$

Source terms: three-phase AC winding $J_s(\theta)$

$$J_A(t) = K_{sfill} J_{srms} \sqrt{2} \cos(\omega t)$$

$$J_B(t) = K_{sfill} J_{srms} \sqrt{2} \cos(\omega t - 2\pi/3)$$

$$J_C(t) = K_{sfill} J_{srms} \sqrt{2} \cos(\omega t + 2\pi/3)$$

At $t = 0$
 \longrightarrow

$$J_A(t=0) = K_{sfill} J_{srms} \sqrt{2}$$

$$J_B(t=0) = -\frac{1}{2} K_{sfill} J_{srms} \sqrt{2}$$

$$J_C(t=0) = -\frac{1}{2} K_{sfill} J_{srms} \sqrt{2}$$

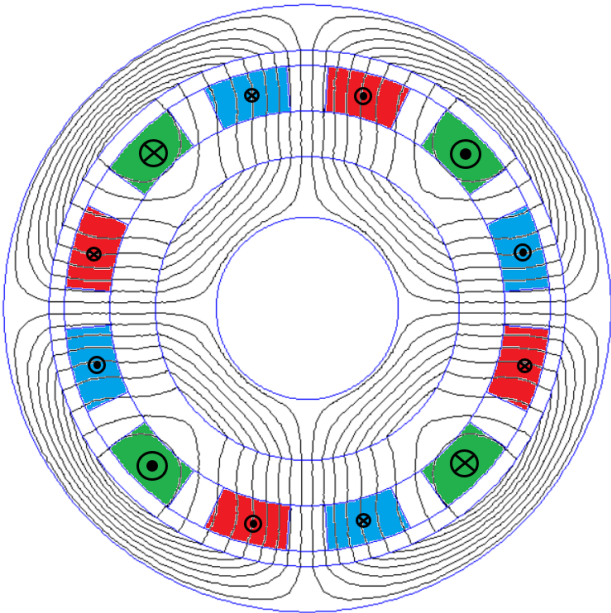

Field distribution at $t = 0$

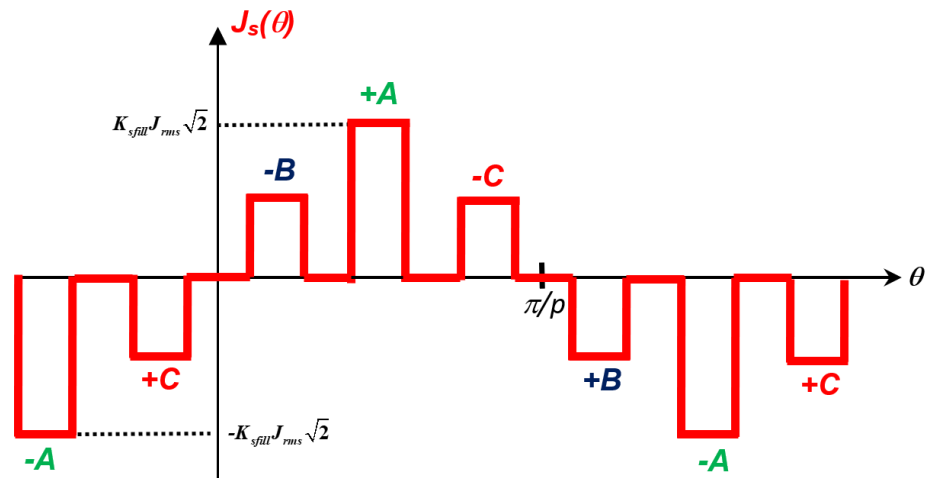

Current density distribution at $t = 0$

$$J_s(\theta) = \sum_{n=1,3,5\dots}^N J_{sn} \sin(np\theta)$$

with

$$J_{sn} = \frac{4}{\pi n} K_{sfill} J_{srms} \sqrt{2} \sin\left(n \frac{\pi}{2}\right) \sin\left(nv \frac{\pi}{6}\right) \left(1 - \cos\left(n \frac{2\pi}{3}\right)\right)$$

Source terms: three-phase AC winding $J_s(\theta)$

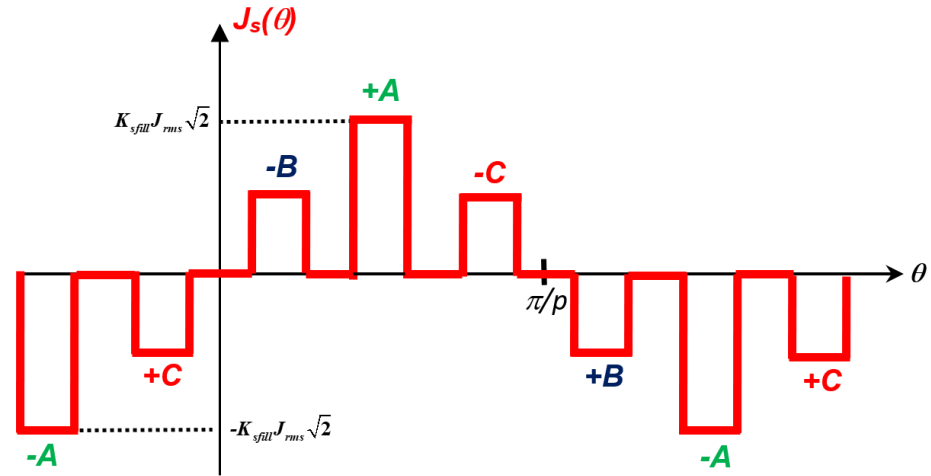
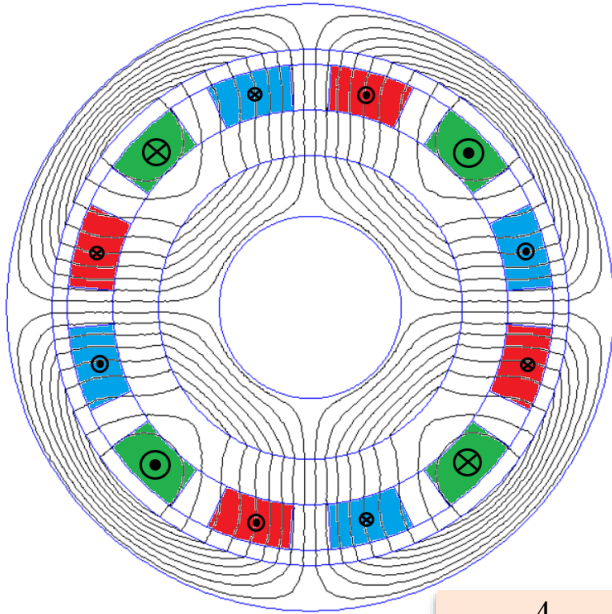

$$J_{sn} = \frac{4}{\pi n} K_{sfill} J_{srms} \sqrt{2} \sin\left(n \frac{\pi}{2}\right) \sin\left(nv \frac{\pi}{6}\right) \left(1 - \cos\left(n \frac{2\pi}{3}\right)\right)$$

$p = 2; v = 0.9$
 $J_{srms} = 20 \text{ A/mm}^2; K_{rfill} = 0,5$

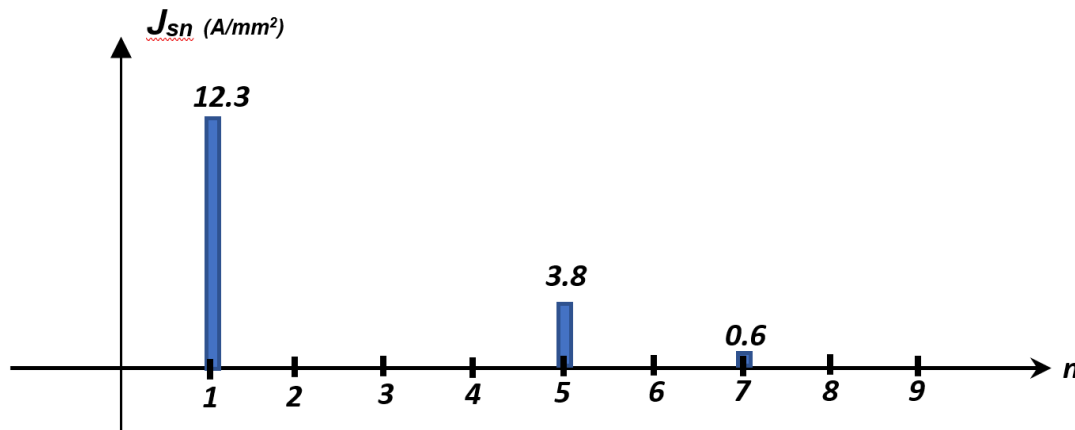

More complicated 3-phase AC winding to reduce the harmonic level

Reduce the harmonic content of the stator winding could be good to avoid AC losses in the HTS coils (due to parasitic rotating field)

Distributed winding and chording (short pitched coil)

Q_s : number of stator "slots"
 p : number of pole pairs
 q : number of slots per pole and per phase

$$q = \frac{Q_s}{6p}$$

Single layer ; $q = 1$; 6 coils

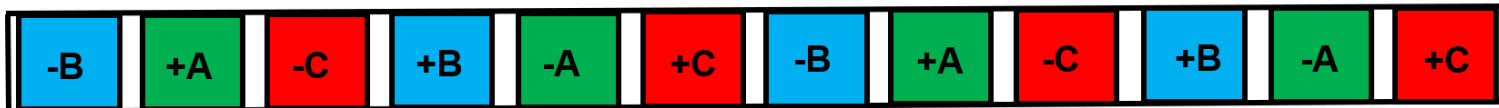

Single layer ; $q = 2$; 12 coils

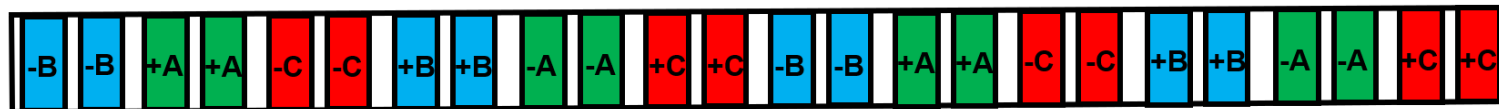

Double layer ; $q = 2$; 24 coils, coil span 5/6

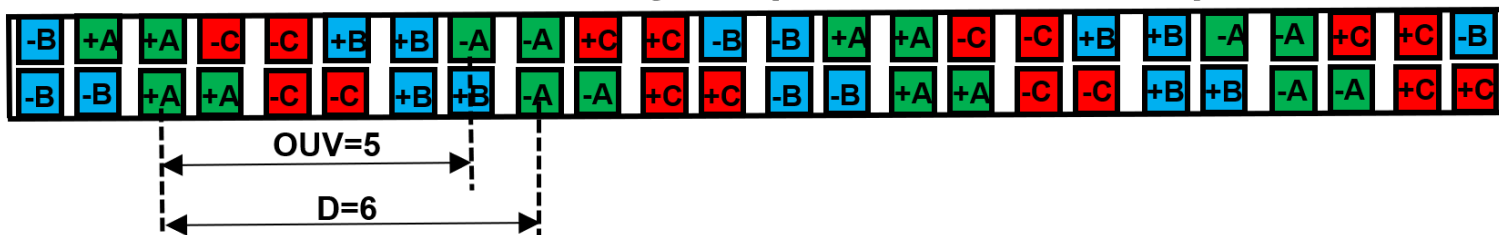

More complicated 3-phase AC winding to reduce the harmonic level

$$J_{sn} = \frac{4}{\pi n} K_{sfill} J_{srms} \sqrt{2} \sin\left(n \frac{\pi}{2}\right) \sin\left(nv \frac{\pi}{6}\right) \left(1 - \cos\left(n \frac{2\pi}{3}\right)\right) \times \underline{K_d(n) K_p(n)}$$

$$K_d(n) = \frac{\sin\left(npq \frac{\pi}{Q_s}\right)}{q \sin\left(np \frac{\pi}{Q_s}\right)}$$

is the distribution factor ; $K_p(n) = \sin\left(n \frac{OUV}{D} \frac{\pi}{2}\right)$ is the pitch factor

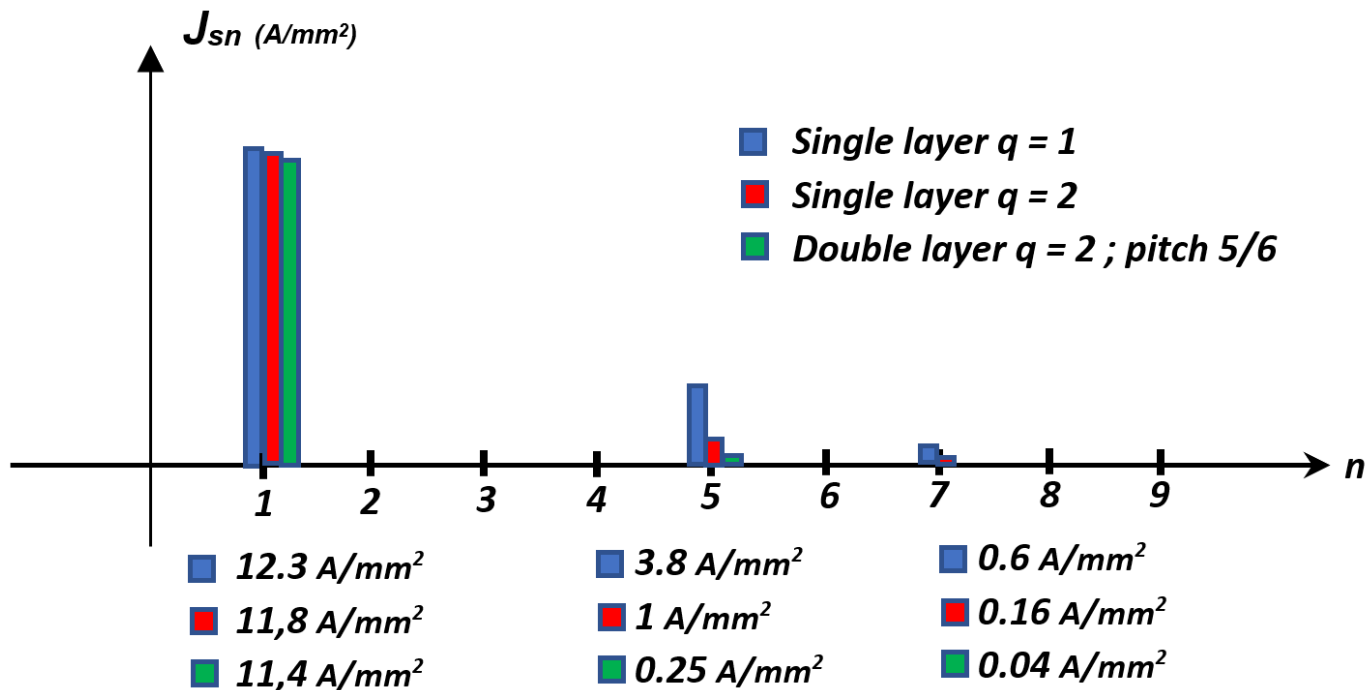

Expression of the Flux density

The magnetic vector potential in each region is written as

$$A_i(r, \theta) = \sum_{n=1,3,5\dots}^N A_{in}(r) \sin(np(\theta + \alpha)) \quad \rightarrow \quad A_i(r, \theta) = \text{Im} \left(\sum_{n=1,3,5\dots}^N \underline{A}_{in}(r) e^{jnp\theta} \right)$$

$$\mathbf{B}_i = \nabla \times \mathbf{A}_i \quad \text{with} \quad \mathbf{A}_i = A_i(r, \theta) \mathbf{u}_z$$

In cylindrical coordinates, we have:

$$\mathbf{B}_i = \frac{1}{r} \frac{\partial A_i}{\partial \theta} \mathbf{u}_r - \frac{\partial A_i}{\partial r} \mathbf{u}_\theta$$

Radial component of \mathbf{B} \rightarrow $B_{ri}(r, \theta) = \text{Im} \left(\sum_{n=1,3,5\dots}^N \underline{B}_{rin}(r) e^{jnp\theta} \right)$

Tangential component of \mathbf{B} \rightarrow $B_{\theta i}(r, \theta) = \text{Im} \left(\sum_{n=1,3,5\dots}^N \underline{B}_{\theta in}(r) e^{jnp\theta} \right)$

$$\underline{B}_{rin}(r) = jnp \frac{1}{r} \underline{A}_{in}(r)$$

$$\underline{B}_{\theta in}(r) = -\frac{d\underline{A}_{in}(r)}{dr}$$

Results and validation with FE simulations

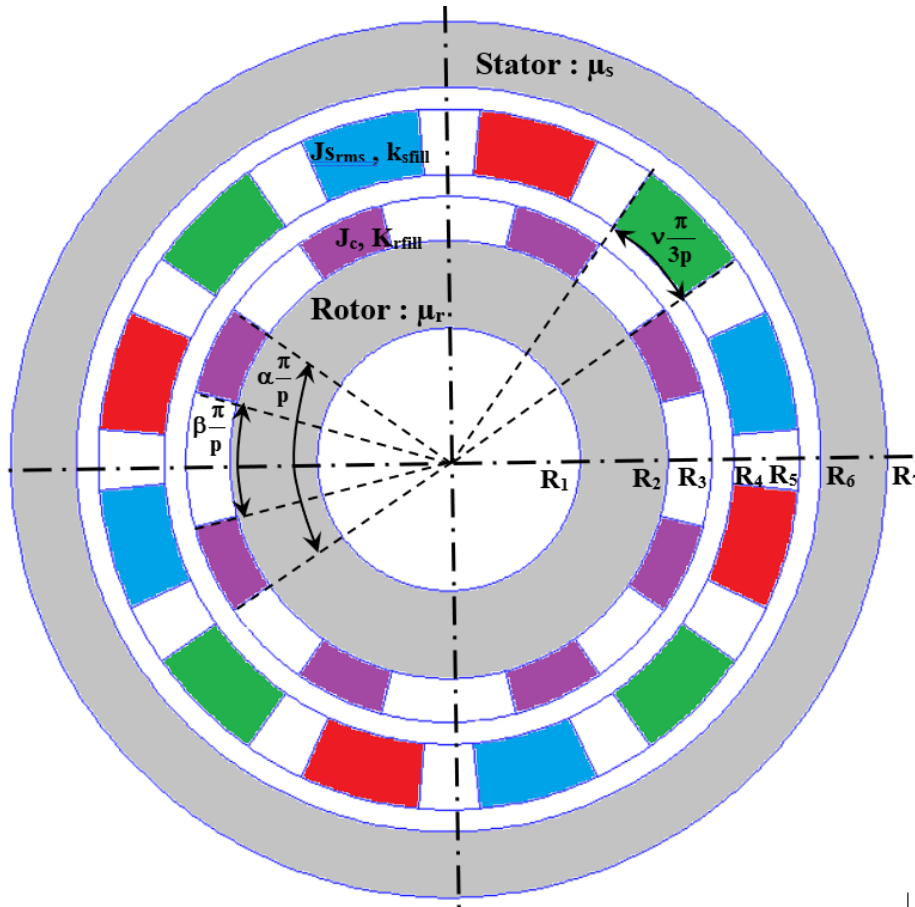

$p = 2$: pole-pairs number

$L = 30$ cm : axial length

$R_1 = 3$ cm : inner radius of the rotor

$a = 2$ cm : thickness rotor yoke

$b = 1$ cm : thickness HTS winding

$c = 0.5$ cm : air-gap thickness

$d = 1.5$ cm : thickness stator winding

$e = 0.5$ cm : 2nd air-gap thickness

$f = 1.5$ cm : thickness stator yoke

$\alpha = 0,777$: outer opening of HTS coils

$\beta = 0.333$: inner opening of the HTS coils

$\nu = 0.666$: opening of the stator coils

$\mu_s = 1000$: stator relative permeability

$\mu_r = 1000$: rotor relative permeability

$J_c = 200$ A/mm² : critical current of the HTS coils (to avoid magnetic saturation)

$k_{r\text{fill}} = 0.7$: fill factor for the HTS coils

$J_{s\text{rms}} = 20$ A/mm² : stator RMS current density

$k_{s\text{fill}} = 0,5$: fill factor for the stator coils

$J_r(\theta)$ and $J_s(\theta)$ computation with Matlab

%Source vector S3 to S6 (HTS rotor current density)

```

for j = 1:nn
    n=2*j-1;
    k=n*p;

    Jrn=(4*k*supra*Jc/(n*pi))*cos(n*beta*pi/2)-cos(n*alpha*pi/2);

    if k==2

        S3(j,1)=(1/16)*muo*Jrn*(R2^2)*(1-4*log(R2))*exp(k*li*delta);
        S4(j,1)=-(1/(16*k))*muo*Jrn*2*R2*(1+4*log(R2))*exp(k*li*delta);
        S5(j,1)=-(1/16)*muo*Jrn*(R3^2)*(1-4*log(R3))*exp(k*li*delta);
        S6(j,1)=(1/(16*k))*muo*Jrn*2*R3*(1+4*log(R3))*exp(k*li*delta);

    else

        S3(j,1)=muo*Jrn*((R2^2)/(k^2-4))*exp(k*li*delta);
        S4(j,1)=muo*Jrn*((2*R2)/(k*(k^2-4)))*exp(k*li*delta);
        S5(j,1)=-muo*Jrn*((R3^2)/(k^2-4))*exp(k*li*delta);
        S6(j,1)=-muo*Jrn*(2*R3/(k*(k^2-4)))*exp(k*li*delta);

    end

    % To plot the rotor current density
    JJR(j,1)=Jrn;
end
    
```

%Source vector S7 to S10 (Stator current density)

```

for j = 1:nn
    n=2*j-1;
    k=n*p;

    Jsn=(4*kcu*Js*sqrt(2)/(pi*n))*sin(n*pi/2)*sin(n*gamma*pi/6)*(1-cos(n*2*pi/3))*(sin(k*q*pi/Ne)/(q*sin(k*pi/Ne)));

    if k==2

        S7(j,1)= (1/16)*muo*Jsn*(R4^2)*(1-4*log(R4));
        S8(j,1)=-(1/(16*k))*muo*Jsn*2*R4*(1+4*log(R4));
        S9(j,1)= -(1/16)*muo*Jsn*(R5^2)*(1-4*log(R5));
        S10(j,1)=(1/(16*k))*muo*Jsn*2*R5*(1+4*log(R5));

    else

        S7(j,1)= muo*Jsn*(R4^2)/(k^2-4);
        S8(j,1)=muo*Jsn*2*R4/(k*(k^2-4));
        S9(j,1)=-muo*Jsn*(R5^2)/(k^2-4);
        S10(j,1)=-muo*Jsn*2*R5/(k*(k^2-4));

    end

    % To plot the stator current density
    JJ(j,1)=Jsn;
end
    
```

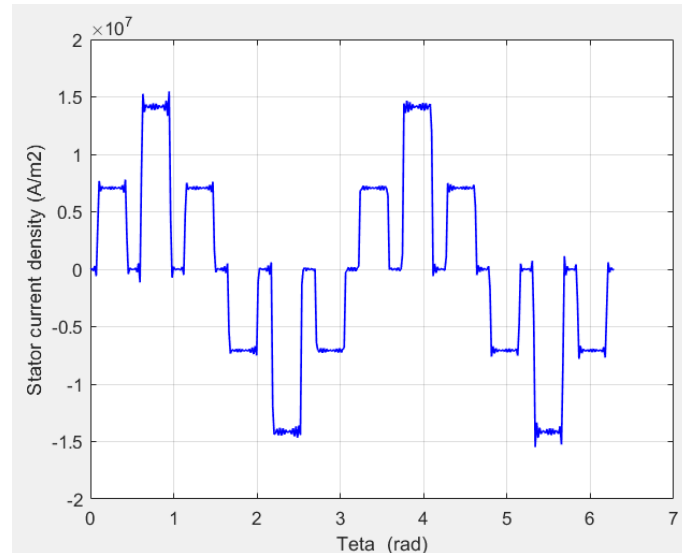
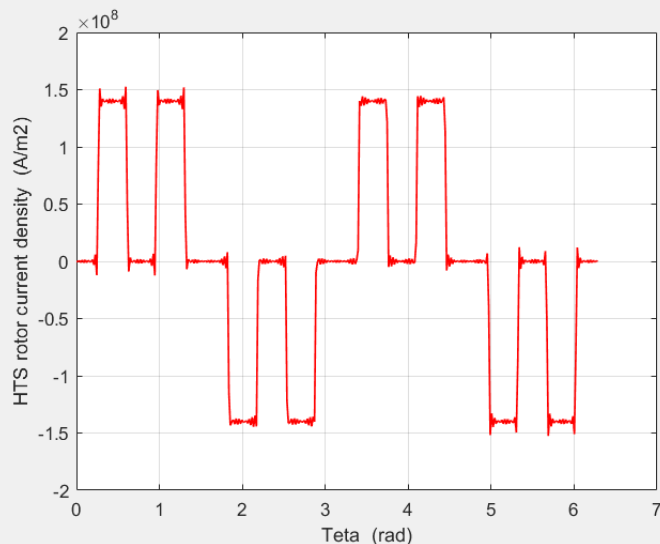

Flux density in the middle of the air-gap under load condition ($\delta = 90^\circ$)

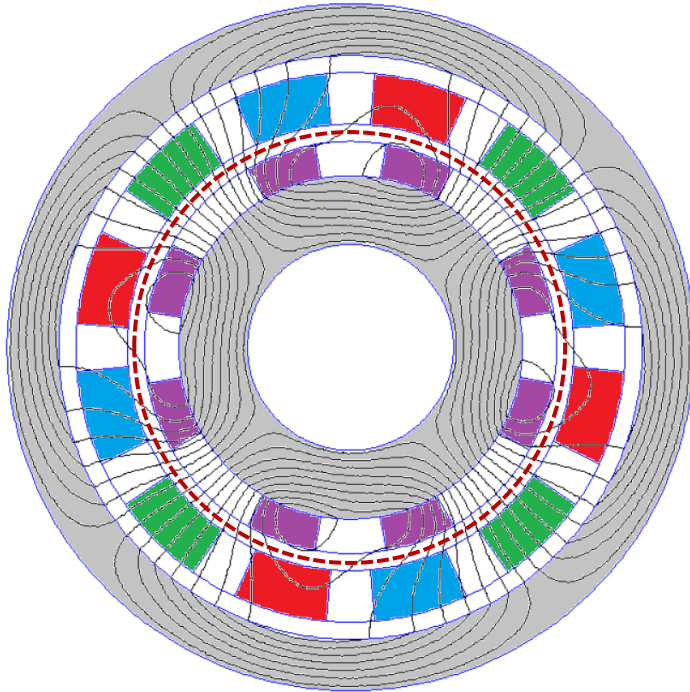

Flux line under Full-load condition (FEMM software)

Torque with FEM: $T = 505 \text{ Nm}$ in 1s
Torque with Analytical: $T = 504 \text{ Nm}$ in 20ms

Computational time 50 times better: good for design optimization procedure

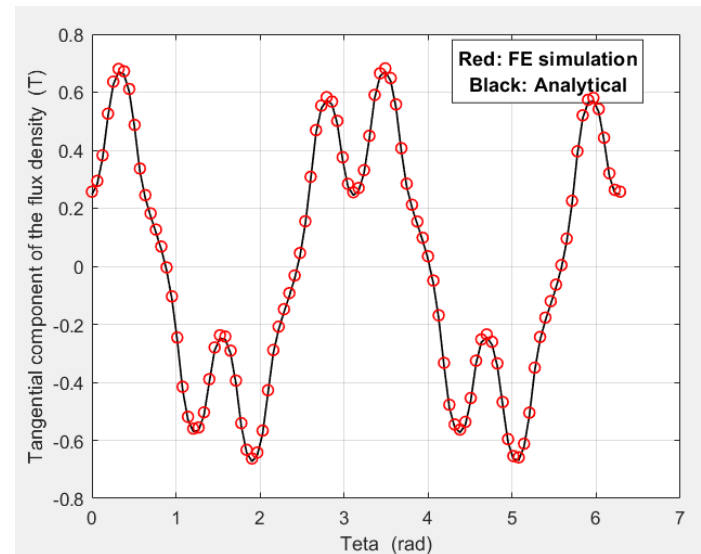
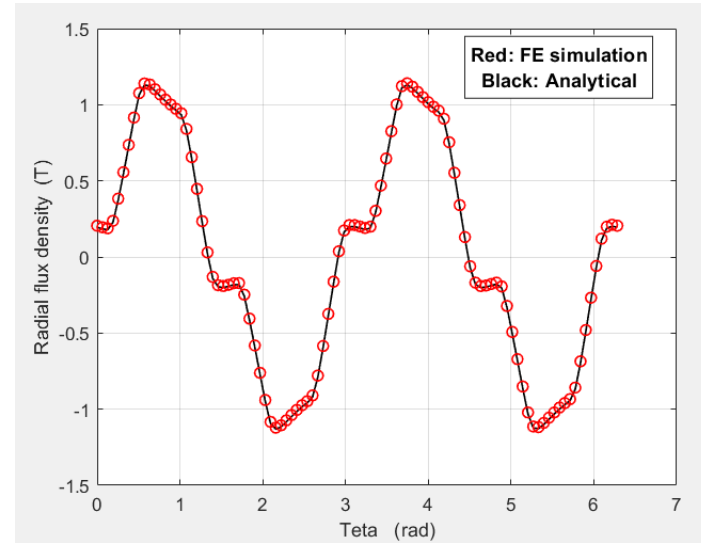

Torque computation: Maxwell Stress Tensor

The torque is compute in the middle of the air-gap (region 4) : less harmonic terms are needed

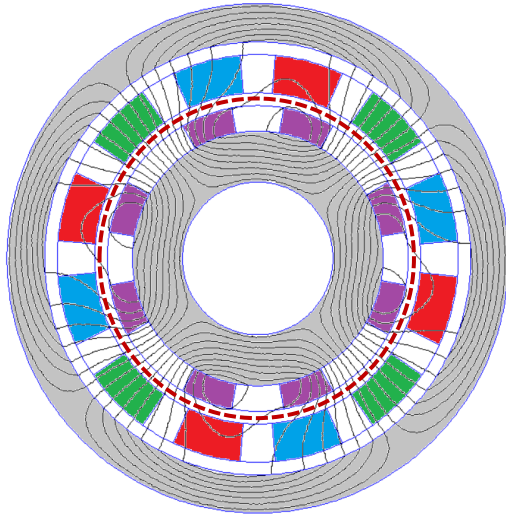

$$T = \frac{LR_m^2}{\mu_0} \int_0^{2\pi} B_{r4}(R_m, \theta) B_{t4}(R_m, \theta) d\theta$$

$$R_m = \frac{R_3 + R_4}{2}$$

With the complex notation, we obtain:

$$\int_0^{2\pi} B_{r4}(R_m, \theta) B_{\theta 4}(R_m, \theta) d\theta = \pi \Re \left\{ \underline{B}_{r4}(R_m) \underline{B}_{\theta 4}^*(R_m) \right\}$$

See slide 27; For harmonic np we have :

$$\underline{B}_{r4}(R_m) = jnp \frac{1}{R_m} \left(\underline{K}_6 R_m^{np} + \underline{K}_7 R_m^{-np} \right)$$

$$\underline{B}_{\theta 4}^*(R_m) = -np \left(\underline{K}_6^* R_m^{np-1} - \underline{K}_7^* R_m^{-np-1} \right)$$

$$T = \frac{\pi L}{\mu_0} \sum_{n=1,3,5\dots} \Re \left\{ j(np)^2 \left(\underline{K}_6^* \underline{K}_7 - \underline{K}_6 \underline{K}_7^* \right) \right\}$$

where \Re is the real part

Static and dynamic torque for the studied example

Static torque

We change the rotor position: $0 < \delta < 90^\circ$
 The current in the stator is fixed: $(I ; -I/2 ; -I/2)$

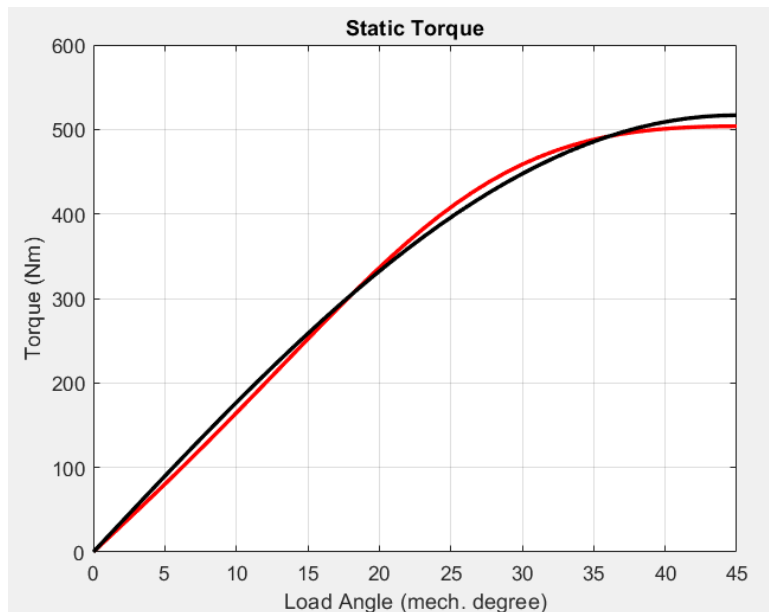

Red: 10 harmonics
Black : fundamental only

Dynamic torque

Incremental variation of the rotor position from the maximal value of the torque: $90^\circ + \Delta\delta$
 The current in the stator coils change as well (current control with inverter and encoder):

$$J_A(\Delta\delta) = K_{sfill} J_{srms} \sqrt{2} \cos(p\Delta\delta)$$

$$J_B(\Delta\delta) = K_{sfill} J_{srms} \sqrt{2} \cos(p\Delta\delta - 2\pi/3)$$

$$J_C(\Delta\delta) = K_{sfill} J_{srms} \sqrt{2} \cos(p\Delta\delta + 2\pi/3)$$

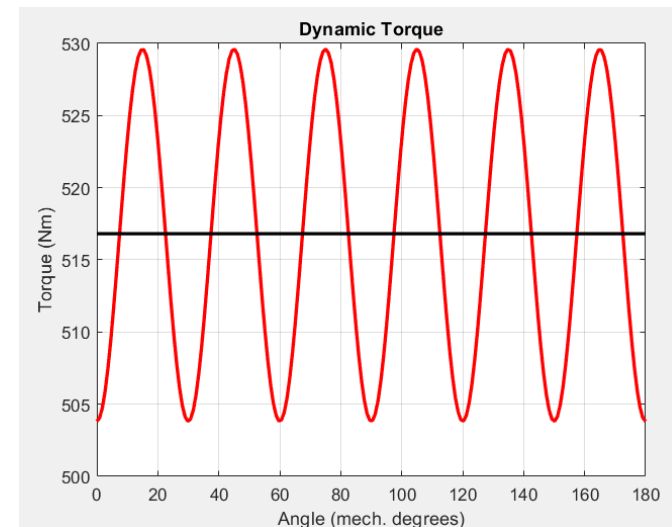

Red: 10 harmonics
Black : fundamental only

Flux and Back-EMF expression

- ◆ Magnetic flux is obtained from the mean value of magnetic vector potential in a stator coil cross-section (Green-Ostrogradsky theorem)

$$\int_S \mathbf{B} \cdot \mathbf{ndS} = \int_S \text{curl} \mathbf{A} \cdot \mathbf{ndS} = \oint_{l_S} \mathbf{A} \cdot \mathbf{tdl} \quad A_z \rightarrow \frac{1}{S_{slot}} \int_{S_{slot}} A_z dS$$

$$\Phi_{slot} = \frac{L}{S_{slot}} \int_{R_4}^{R_5} \int_{-\frac{v\pi}{6p}}^{\frac{v\pi}{6p}} A_5(r, \theta) r dr d\theta \quad \longrightarrow \quad \Phi_{phase} = \frac{2pL}{S_{slot}} \int_{R_4}^{R_5} \int_{-\frac{v\pi}{6p}}^{\frac{v\pi}{6p}} A_5(r, \theta) r dr d\theta$$

Regular distributed winding (*2p)

$$\Phi_{phase}(\delta) = \frac{4pL}{S_{slot}} \sum_{n=1,3,5\dots} \frac{1}{np} \sin\left(\frac{npv\pi}{6p}\right) \times \text{Im} \left\{ j \left(\underline{K}_8 \frac{R_5^{np+2} - R_4^{np+2}}{np+2} - \underline{K}_9 \frac{R_5^{-np+2} - R_4^{-np+2}}{np-2} \right) \right\} \quad \text{for } np \neq 2$$

$$\Phi_{phase}(\delta) = \frac{2pL}{S_{slot}} \sin\left(\frac{v\pi}{3p}\right) \times \text{Im} \left\{ j \left(\frac{1}{4} \underline{K}_8 (R_5^4 - R_4^4) + \underline{K}_9 \ln\left(\frac{R_5}{R_4}\right) \right) \right\} \quad \text{for } np = 2$$

- ◆ The back EMF is obtained from the derivative of the flux

$$E_a(\delta) = -N_c \Omega \frac{d\Phi_{phase}}{d\delta} \quad \text{with } \Omega = \frac{d\delta}{dt} \quad (\delta \text{ is the mechanical position})$$

N_c : number of conductors in the slot

Flux and Back-EMF computation for the studied example (for 1 conductor/slot)

No load ($J_{srms} = 0 \text{ A/mm}^2$) ; $\Omega = 314 \text{ rad/s}$
 Red: 10 harmonics ; Black : fundamental only

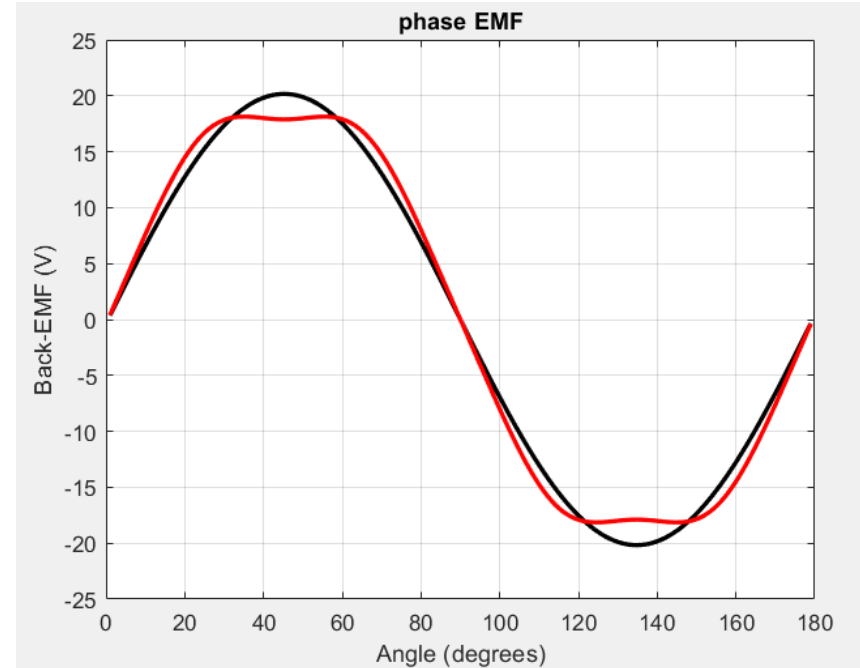
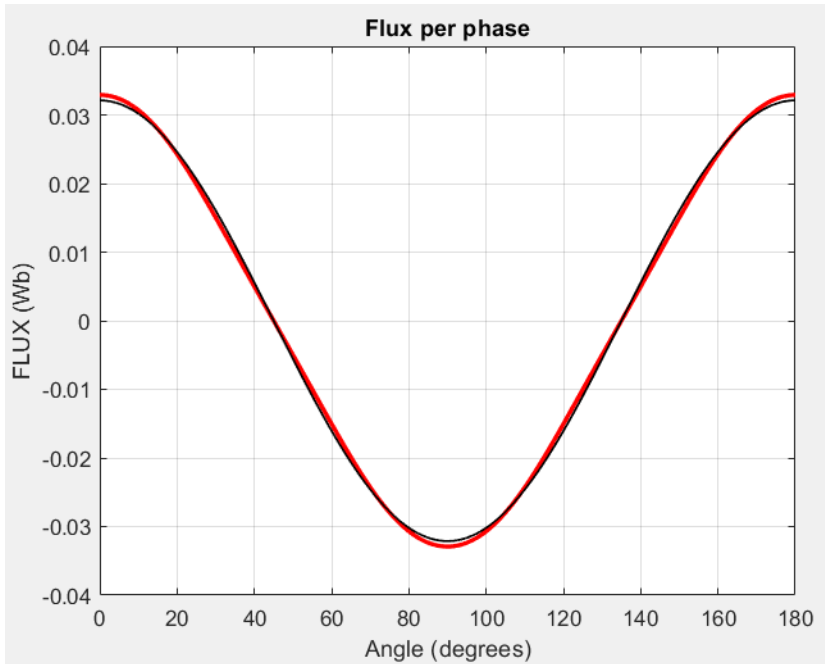

Rapid verification:

$$3EI = C\Omega \quad \text{with} \quad C = 504 \text{ Nm} \quad \text{and} \quad \Omega = 314 \text{ rd/s}$$

$$\text{We have } S_{slot} = 3.7923 \cdot 10^{-4} \text{ m}^2 \quad \text{and} \quad I = k_{sfill} J_{srms} S_{slot} = 0.5 \times 20 \cdot 10^6 \times 3.7923 \cdot 10^{-4} = 3792 \text{ A}$$

$$E = \frac{C\Omega}{3I} = 13.9 \text{ A} \rightarrow E_{\max} = 19.8 \text{ V} \quad (\text{for 1 conductor per slot!})$$

Design Optimization of an HTS machine

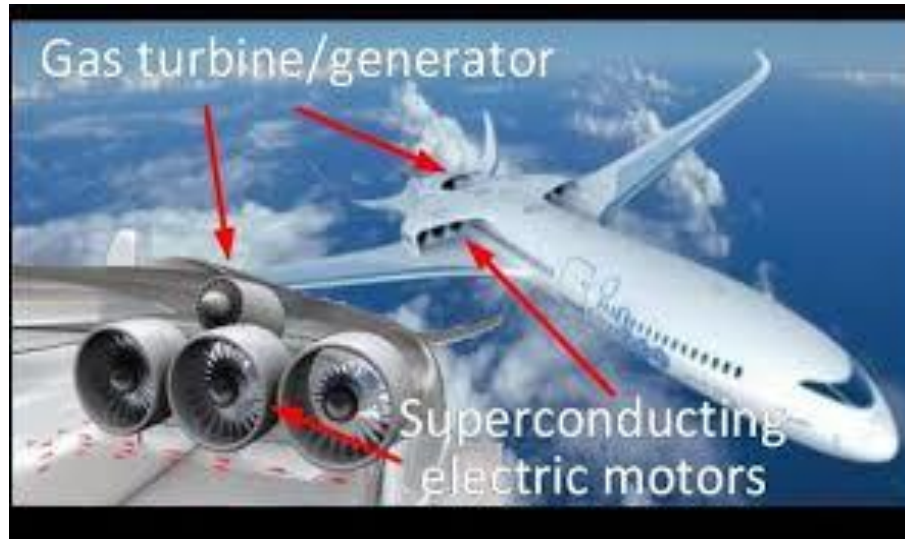

More Electrical Aircraft Motor propulsion

$$P = 3 \text{ MW} ; N = 3000 \text{ rpm} \rightarrow T = 9500 \text{ Nm}$$

Power to Mass ratio > 20 kW/kg ????

Genetic Algorithm available in Matlab Optimization Toolbox

A genetic algorithm (GA) is a method for solving both constrained and unconstrained optimization problems based on a natural selection process that mimics biological evolution. The algorithm repeatedly modifies a population of individual solutions. At each step, the genetic algorithm randomly selects individuals from the current population and uses them as parents to produce the children for the next generation. Over successive generations, the population "evolves" toward an optimal solution.

Mono-objective Design Optimization

Constraint $\rightarrow T = 9500 \text{ Nm}$

1 objective \rightarrow Minimum active mass (HTS and copper coils)

Totally iron less machine ($\mu_s = \mu_r = 1$) ; $R_1 = R_2$; $R_5 = R_6 = R_7$

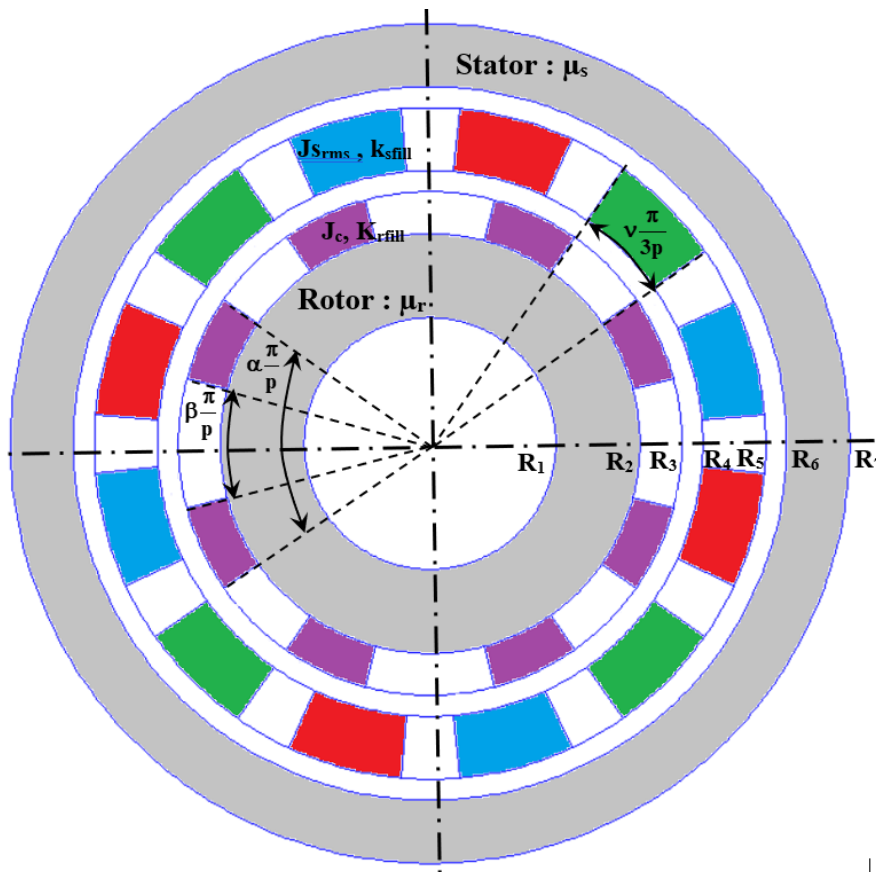

$p = x(1)$: pole-pairs number

$R_1 = x(2)$: inner radius of the rotor

$a = x(3) = 0 \text{ cm}$: thickness rotor yoke

$b = x(4)$: thickness HTS winding

$c = 1 \text{ cm}$: air-gap thickness (fixed)

$d = x(5)$: thickness stator winding

$e = x(6) = 0 \text{ cm}$: 2nd air-gap thickness

$f = x(7) = 0 \text{ cm}$: thickness stator yoke

$L = x(8)$: axial length

$\alpha = x(9)$: outer opening of HTS coils

$\beta = x(10)$: inner opening of the HTS coils

$v = x(11)$: opening of the stator coils

$\mu_s = 1$: stator relative permeability

$\mu_r = 1$: rotor relative permeability

$J_c = 200 \text{ and } 300 \text{ A/mm}^2$; $K_{r\text{fill}} = 0.7$

$J_{s\text{rms}} = 20 \text{ A/mm}^2$; $K_{s\text{fill}} = 0,5$

Active mass expression

We have to write the active mass (HTS and copper coils) as a function of the geometrical parameters

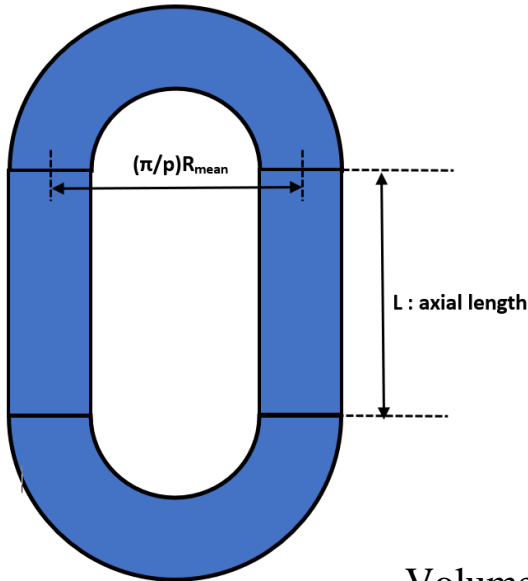

◆ **Copper coils** $\rho_{cop} = 8960 \text{kgm}^{-3}$:

$$\text{Volume active parts : } V_{apcop} = \pi v (R_5^2 - R_4^2) k_{sfill} L$$

$$\text{Volume End winding part : } V_{EWcop} = \frac{\pi^3 v (R_5^2 - R_4^2) (R_5 + R_4) k_{sfill}}{4p}$$

$$\text{Copper mass : } M_{cop} = \rho_{cop} (V_{apcop} + V_{EWcop})$$

◆ **HTS coils** $\rho_{HTS} = 5500 \text{kgm}^{-3}$:

$$\text{Volume active parts : } V_{apHTS} = \pi (\alpha - \phi) (R_3^2 - R_2^2) k_{rfill} L$$

$$\text{Volume End winding part : } V_{EWHTS} = \frac{\pi^3 (\alpha + \beta) (\alpha - \beta) (R_3^2 - R_2^2) (R_3 + R_2) k_{rfill}}{8p}$$

$$\text{HTS mass : } M_{HTS} = \rho_{HTS} (V_{apHTS} + V_{EWHTS})$$

$$\text{Total mass : } M_T = M_{apcop} + M_{EWcop}$$

Design Optimization with Matlab Toolbox

- ◆ We have to define two Matlab function functions: `constraint.m` and `objective.m`
`constraint.m`: return the value of the constraint (torque)
`Objective.m`: return the value of the objective (Mass of the windings)
- ◆ We have to choose an optimization method: mono objective Genetic Algorithm (`ga.m`)
- ◆ We have 11 variables with 1 integer (number of pole-pairs). We have to choose lower and upper bounds for this variables (not easy, trial and errors....)

Variable	Number		Lower	Upper
p	Pole-pairs number (integer)	x(1)	1	10
R ₁	Inner radius of the rotor (cm)	x(2)	10	40
a	Thickness rotor yoke (cm)	x(3)	0	0
b	Thickness HTS winding (cm)	x(4)	0.5	2
d	Thickness stator winding (cm)	x(5)	0.5	5
e	2 nd air-gap thickness (cm)	x(6)	0	0
f	Thickness stator yoke (cm)	x(7)	0	0
L	Axial length (cm)	x(8)	20	50
α	Outer opening HTS coils	x(9)	0	1
β	Inner opening HTS coils	x(10)	0.1	1
v	Opening of the stator coils	x(11)	0.5	1

Design Optimization with Matlab Toolbox

```
constraint.m  objective.m  machine_8_domaines.m  machine_8_domaines_couple_statique.m  n
1  function [cin,ceq]=constraint(x)
2
3
4  nn=1;                % Number of harmonic terms
5
6  muo=4*pi*1e-7;      % Air permeability
7  mur=1;               % Relative permeability of the rotor yoke
8  mus=1;               % Relative permeability of the stator yoke
9
10 % Geometrical parameters (cm)
11
12 p=x(1);              % Pole-pairs number
13 R1=x(2)*1e-2;       % Inner radius of the rotor yoke
14 a=x(3)*1e-2;        % Thickness of the rotor yoke
15 b=x(4)*1e-2;        % Thickness of the HTS winding (rotor)
16 c=1e-2;              % Air-gap thickness
17 d=x(5)*1e-2;        % Thickness of the stator winding
18 e=x(6)*1e-2;        % Second air-gap thickness
19 f=x(7)*1e-2;        % Thickness of the stator yoke
20
21
22
23
24
25
26
27
28
29
30
31
32
33
34
35
36
37
38
39
40
41
42
43
44
45
46
47
48
49
50
51
52
53
54
55
56
57
58
59
60
61
62
63
64
65
66
67
68
69
70
71
72
73
74
75
76
77
78
79
80
81
82
83
84
85
86
87
88
89
90
91
92
93
94
95
96
97
98
99
100
101
102
103
104
105
106
107
108
109
110
111
112
113
114
115
116
117
118
119
120
121
122
123
124
125
126
127
128
129
130
131
132
133
134
135
136
137
138
139
140
141
142
143
144
145
146
147
148
149
150
151
152
153
154
155
156
157
158
159
160
161
162
163
164
165
166
167
168
169
170
171
172
173
174
175
176
177
178
179
180
181
182
183
184
185
186
187
188
189
190
191
192
193
194
195
196
197
198
199
200
201
202
203
204
205
206
207
208
209
210
211
212
213
214
215
216
217
218
219
220
221
222
223
224
225
226
227
228
229
230
231
232
233
234
235
236
237
238
239
240
241
242
243
244
245
246
247
248
249
250
251
252
253
254
255
256
257
258
259
260
261
262
263
264
265
266
267
268
269
270
271
272
273
274
275
276
277
278
279
280
281
282
283
284
285
286
287
288
289
290
291
292
293
294
295
296
297
298
299
300
301
302
303
304
305
306
307
308
309
310
311
312
313
314
315
316
317
318
319
320
321
322
323
324
325
326
327
328
329
330
331 % Torque calculation
332 %
333 for n = 1:nn
334     j=2*n-1;
335     Th=Th+(1/muo)*pi*L*((j*p)^2)*real(1i*(conj(K6n(n))*K7n(n)-K6n(n)*conj(K7n(n))));
336
337 end
338
339 C=Th;
340
341 cin(1)=abs(C-9500)-10; % the constaint corresponds to Torque = 9500Nm
342 ceq=[];
343
344 end
```

Design Optimization with Matlab Toolbox

```
Editor - C:\LUBIN\RECHERCHE\Recherche_2020\Ecole_été_supra\presentation\programme\optimisation_mono_objectif\objective.m
constraint.m  objective.m  machine_8_domaines.m  machine_8_domaines_couple_statique.m  machine_8_domaines_fem.m  mac
1  function vol=objective(x) % active mass
2
3  Rocu=8960; % Density of copper
4  Roacier=8000; % Density of iron
5  Rosupra=5500; % Density of superconducting winding
6  ksupra=0.7; % Filling factor of the HTS coil
7  kcu=0.5; % Filling factor of the stator coil
8  c=1e-2; % Air-gap value
9  VR=1e-6*Roacier*pi*x(3)*(x(3)+2*x(2))*x(8); % Weight of the rotor yoke
10 VS=1e-6*Roacier*pi*x(7)*(x(7)+2*(x(2)+x(3)+x(4)+c+x(5)+x(6)))*x(8); % Weight of the stator yoke
11 Vsupra=1e-6*(Rosupra*ksupra*pi*(x(9)-x(10))*x(4)*(x(4)+2*x(2)+2*x(3))*x(8)+(Rosupra*ksupra*pi^3*(x(
12 Vcu=1e-6*(Rocu*kcu*pi*x(11)*x(5)*(x(5)+2*(x(2)+x(3)+x(4)+c))*x(8)+Rocu*kcu*pi^3*x(11)*x(5)*(x(5)+2*
13
14 %vol(1)=VR+VS+Vsupra+Vcu; % total weight
15 vol(1)=Vsupra+Vcu; % activ weight
16
17
18 end
```

Design Optimization with Matlab Toolbox

Problem Setup and Results

Solver: **ga - Genetic Algorithm**

Problem

Fitness function: **@objective**

Number of variables: **11**

Constraints:

Linear inequalities: A: b:

Linear equalities: Aeq: beq:

Bounds: Lower: Upper:

Nonlinear constraint function: **@constraint**

Integer variable indices: **1**

Run solver and view results

Use random states from previous run

Start **Pause** **Stop**

Current iteration: **766** **Clear Results**

Warning: Matrix is close to singular or badly scaled. Results may be inaccurate. RCOND = 2.051210e-16

Objective function value: 46.237592163394886

Optimization terminated: average change in the penalty fitness value less than options.FunctionTolerance and constraint violation is less than options.ConstraintTolerance.

Final point:

1	2	3	4	5	6	7	8	9	10	11
10	39.774	0	0.871	0.85	0	0	22.946	0.999	0.275	0.786

Options

Population

Population type: **Double vector**

Population size: Use default: max(min(10*numberOfVariables, 100), 40)
 Specify: **1000**

Creation function: **Uniform**

Initial population: Use default: []
 Specify:

Initial scores: Use default: []
 Specify:

Initial range: Use default: []
 Specify:

Fitness scaling

Scaling function: **Rank**

Selection

Selection function: **Stochastic uniform**

Reproduction

Elite count: Use default: 0.05*max(min(10*numberOfVariables, 100), 40)
 Specify:

Crossover fraction: Use default: 0.8

◆ To reduce the mass, the algorithm tends to maximize the radius and the pole pair number (small end-winding), we obtain 46kg → 65kW/kg! (active mass)

Design Optimization with Matlab Toolbox

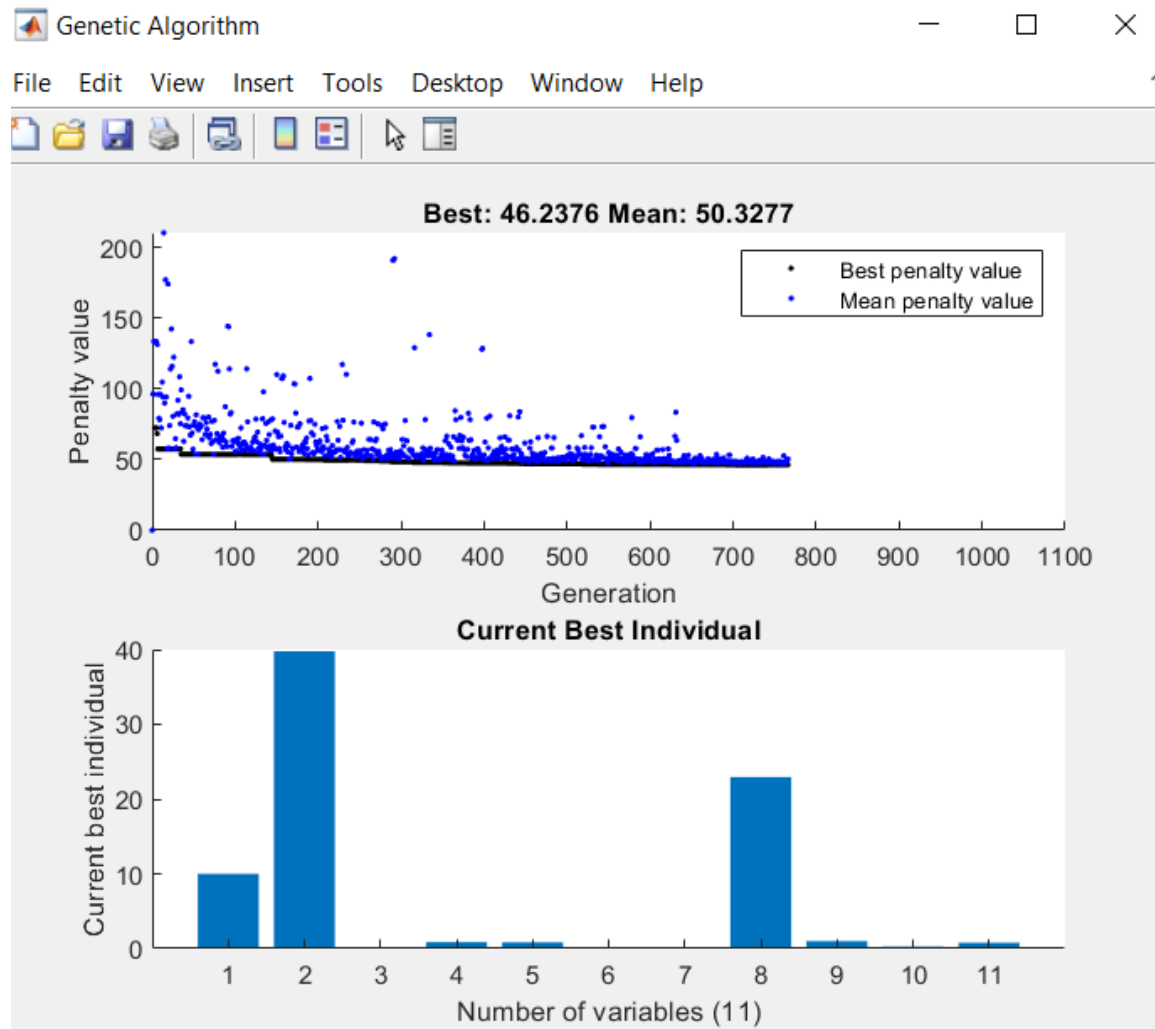

Design Optimization with Matlab Toolbox

- ◆ If we have a constraint on the radius, we can impose $R_1 = 25\text{cm}$ (for example)

Variable	Number		Lower	Upper
p	Pole-pairs number (integer)	x(1)	1	10
R_1	Inner radius of the rotor (cm)	x(2)	25	25
a	Thickness rotor yoke (cm)	x(3)	0	0
b	Thickness HTS winding (cm)	x(4)	0.5	2
d	Thickness stator winding (cm)	x(5)	0.5	5
e	2 nd air-gap thickness (cm)	x(6)	0	0
f	Thickness stator yoke (cm)	x(7)	0	0
L	Axial length (cm)	x(8)	20	50
α	Outer opening HTS coils	x(9)	0	1
β	Inner opening HTS coils	x(10)	0.1	1
v	Opening of the stator coils	x(11)	0.5	1

Design Optimization with Matlab Toolbox

Problem Setup and Results

Solver: **ga - Genetic Algorithm**

Problem

Fitness function: **@objective**

Number of variables: **11**

Constraints:

Linear inequalities: A: b:

Linear equalities: Aeq: beq:

Bounds: Lower: Upper:

Nonlinear constraint function: **@constraint**

Integer variable indices: **1**

Run solver and view results

Use random states from previous run

Start **Pause** **Stop**

Current iteration: **448** **Clear Results**

Optimization running

Objective function value: **52.47960334612428**

Optimization terminated: average change in the penalty fitness value less than options.FunctionTolerance and constraint violation is less than options.ConstraintTolerance.

Final point:

1	2	3	4	5	6	7	8	9	10	11
6	25	0	1.202	1.422	0	0	25.9	1	0.259	0.75

Options

Population

Population type: **Double vector**

Population size: Use default: max(min(10*numberOfVariables, 100), 40)
 Specify: **500**

Creation function: **Uniform**

Initial population: Use default: []
 Specify:

Initial scores: Use default: []
 Specify:

Initial range: Use default: []
 Specify:

Fitness scaling

Scaling function: **Rank**

Selection

Selection function: **Stochastic uniform**

Reproduction

Elite count: Use default: 0.05*max(min(10*numberOfVariables, 100), 40)
 Specify:

Crossover fraction: Use default: 0.8
 Specify:

◆ This increases the axial length... we obtain 52.5kg → 57 kW/kg! (active mass)

Design Optimization with Matlab Toolbox

Results: Flux density in the air-gap

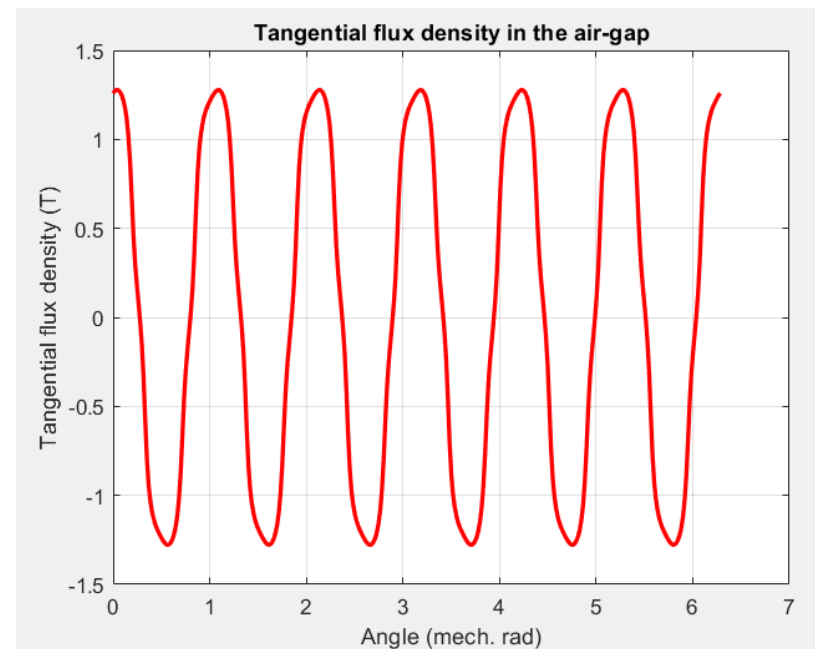
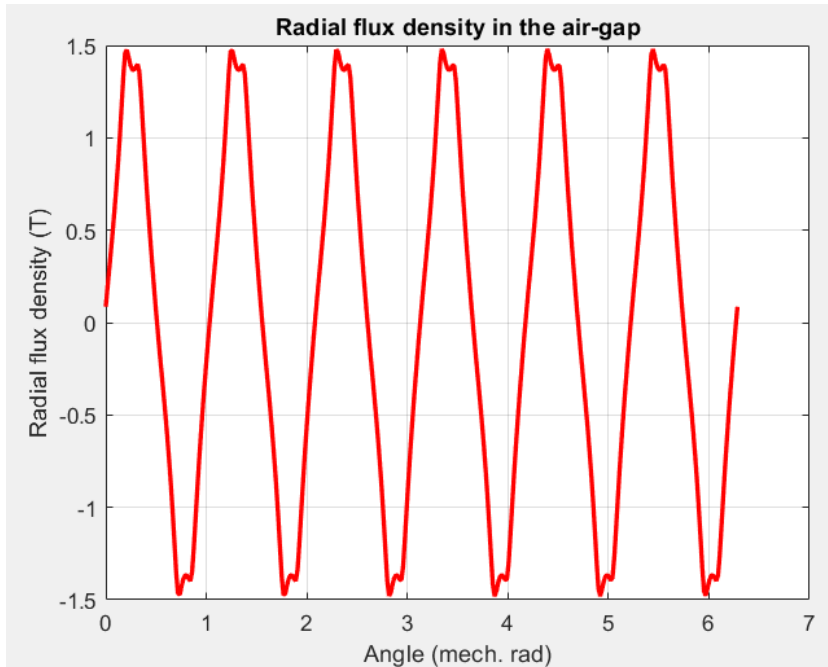

Design Optimization with Matlab Toolbox

Results: Static and dynamic torque

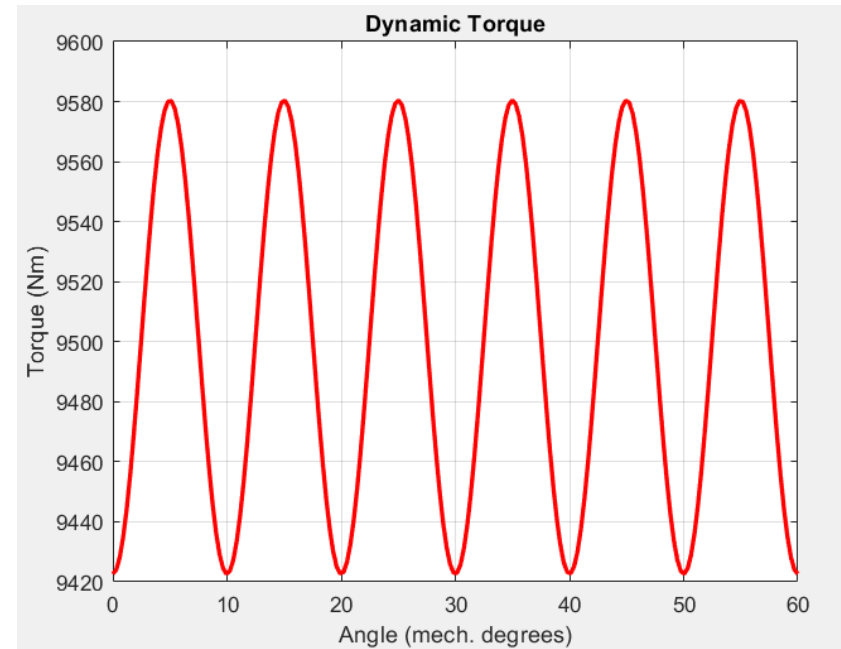
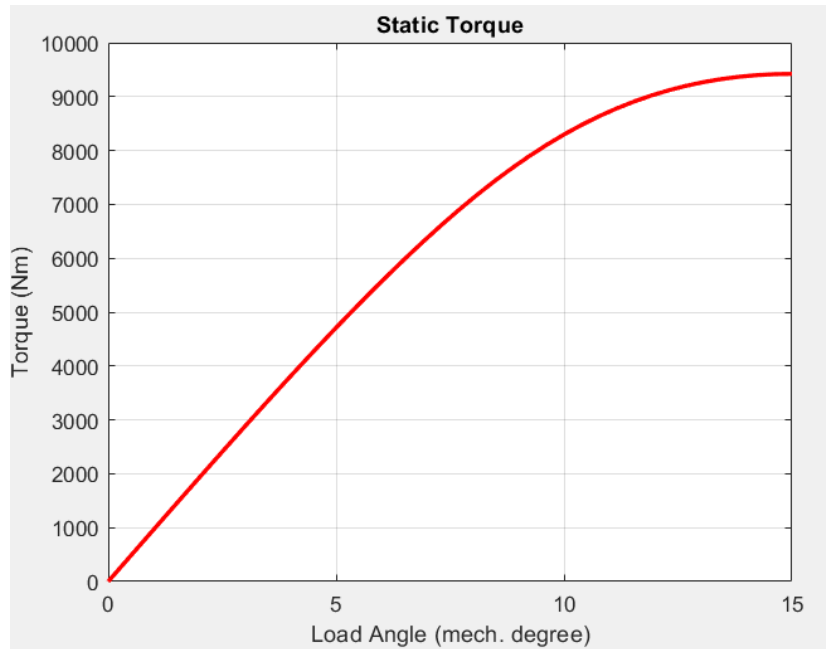

Design Optimization with Matlab Toolbox

Results: Back EMF (1 conductor/slot)

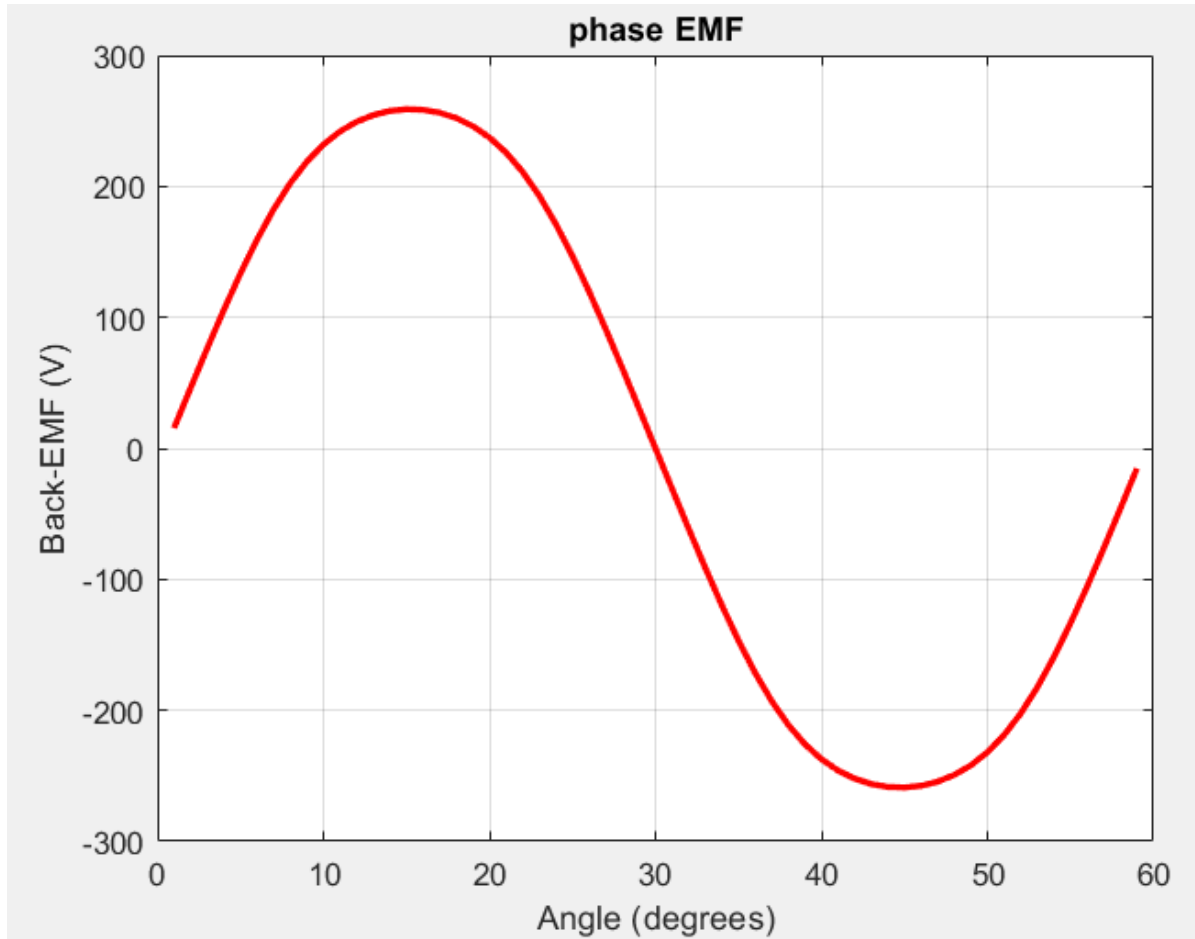

HTS winding verification for the critical current density (needs to be done....)

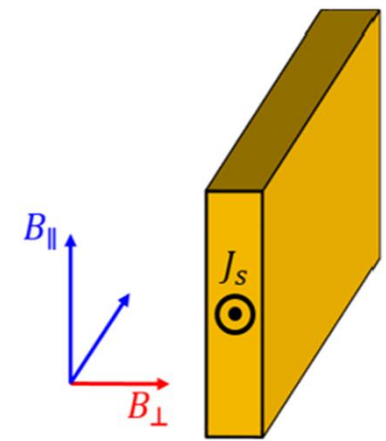
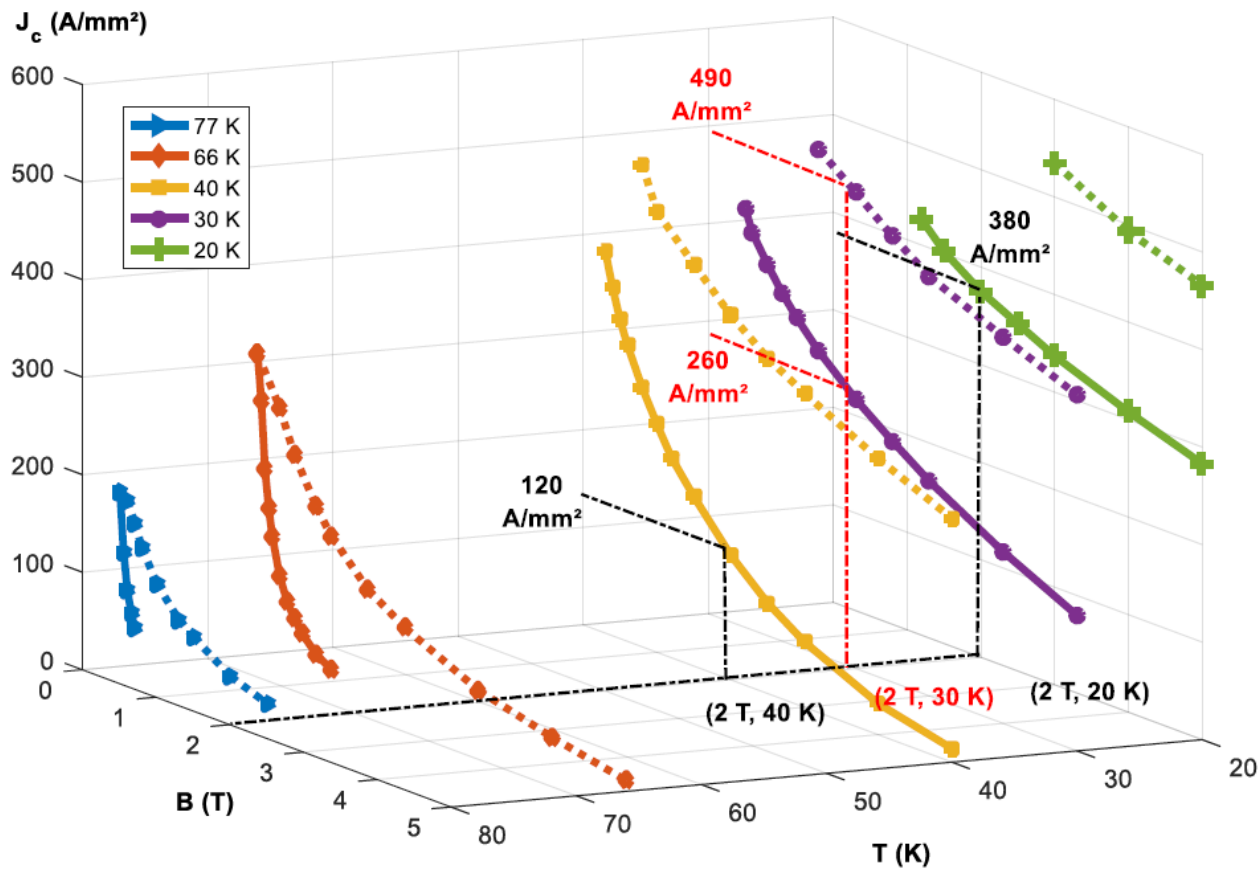

◆ This should be include in the design procedure..... Perhaps the maximal constraint is on the end-winding (3D model.....)

HTS winding verification for the critical current density (needs to be done....)

- ◆ B on HTS wire is never greater than 1.65T; Under 30K $J_c = 300\text{A}/\text{mm}^2$ can be correct

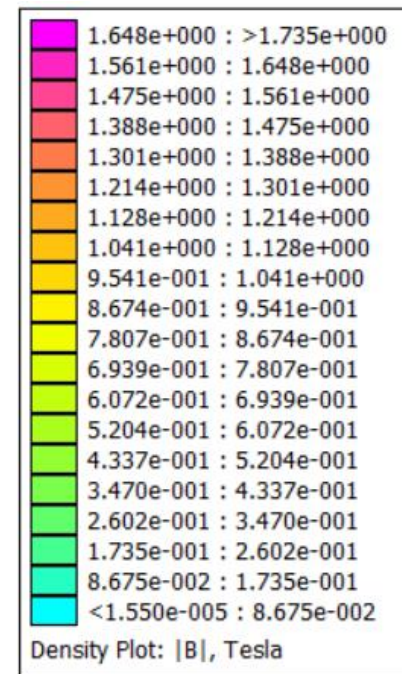
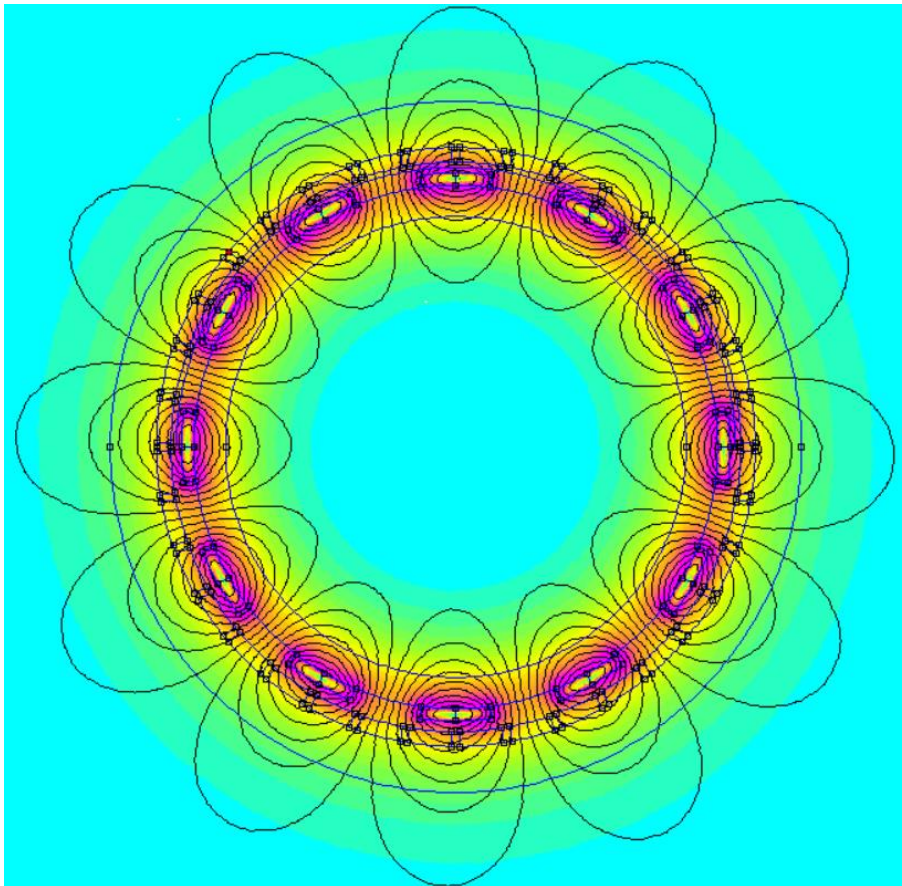

Multi-objective Design Optimization

gamultiobj.m

- ◆ We have to define two Matlab function functions: `constraint.m` and `objective.m`
`constraint.m`: return the value of the constraint (torque)
`Objective.m`: return the value of the objectives
- ◆ We have to choose an optimization method: multi objective Genetic Algorithm (`gamultiobj.m`)

Two antagonist objectives: minimize the mass and minimize R_2

Variable	Number		Lower	Upper
p	Pole-pairs number (integer)	x(1)	1	10
R_1	Inner radius of the rotor (cm)	x(2)	10	40
a	Thickness rotor yoke (cm)	x(3)	0	0
b	Thickness HTS winding (cm)	x(4)	0.5	2
d	Thickness stator winding (cm)	x(5)	0.5	5
e	2 nd air-gap thickness (cm)	x(6)	0	0
f	Thickness stator yoke (cm)	x(7)	0	0
L	Axial length (cm)	x(8)	20	50
α	Outer opening HTS coils	x(9)	0	1
β	Inner opening HTS coils	x(10)	0.1	1
v	Opening of the stator coils	x(11)	0.5	1

Multi-objective Design Optimization

MATLAB R2019b - academic use

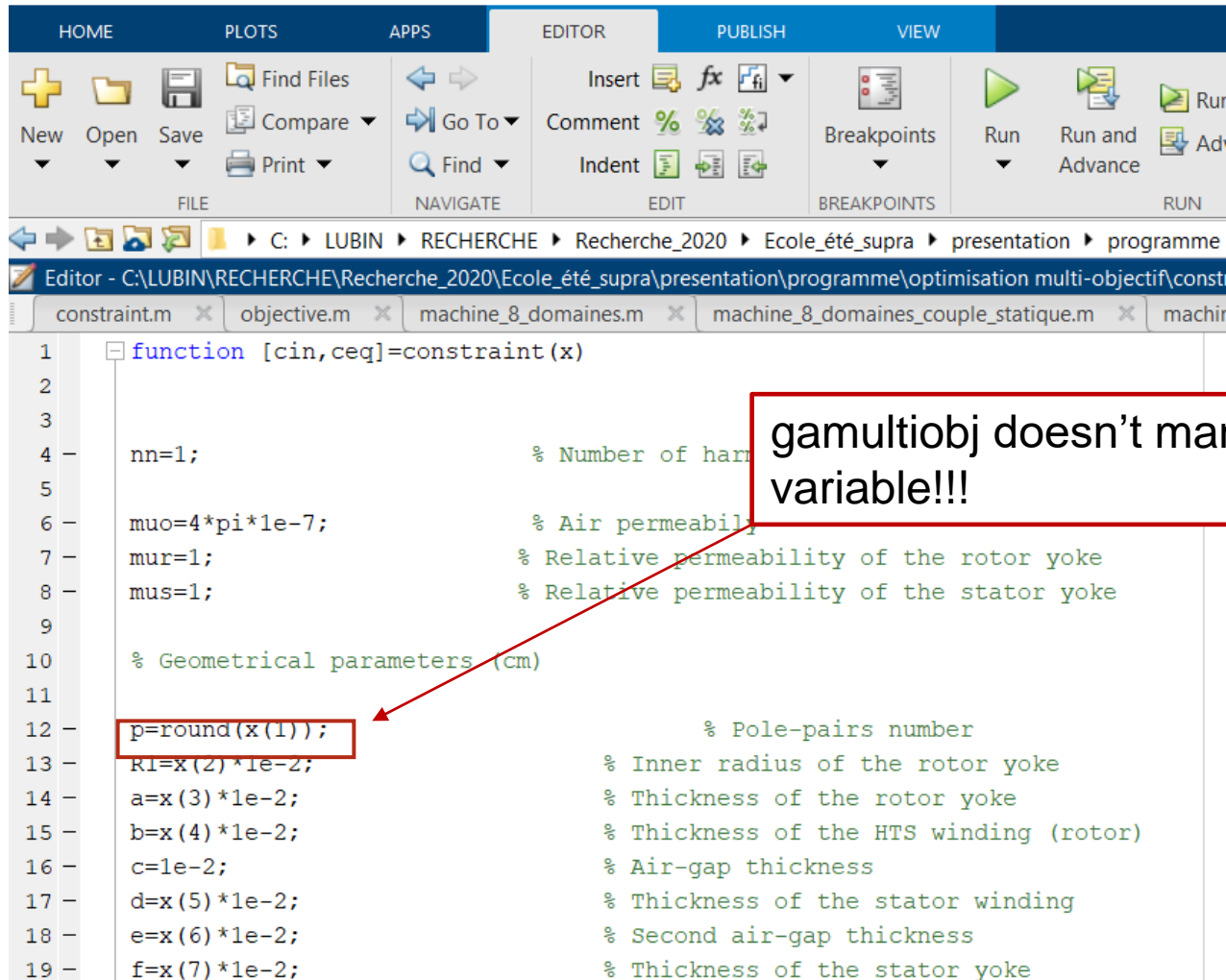

```
1 function [cin,ceq]=constraint(x)
2
3
4 nn=1; % Number of harmonics
5
6 muo=4*pi*1e-7; % Air permeability
7 mur=1; % Relative permeability of the rotor yoke
8 mus=1; % Relative permeability of the stator yoke
9
10 % Geometrical parameters (cm)
11
12 p=round(x(1)); % Pole-pairs number
13 R1=x(2)*1e-2; % Inner radius of the rotor yoke
14 a=x(3)*1e-2; % Thickness of the rotor yoke
15 b=x(4)*1e-2; % Thickness of the HTS winding (rotor)
16 c=1e-2; % Air-gap thickness
17 d=x(5)*1e-2; % Thickness of the stator winding
18 e=x(6)*1e-2; % Second air-gap thickness
19 f=x(7)*1e-2; % Thickness of the stator yoke
```

gamultiobj doesn't manage the integer variable!!!

Multi-objective Design Optimization: Pareto front ($J_c = 300 \text{ A/mm}^2$)

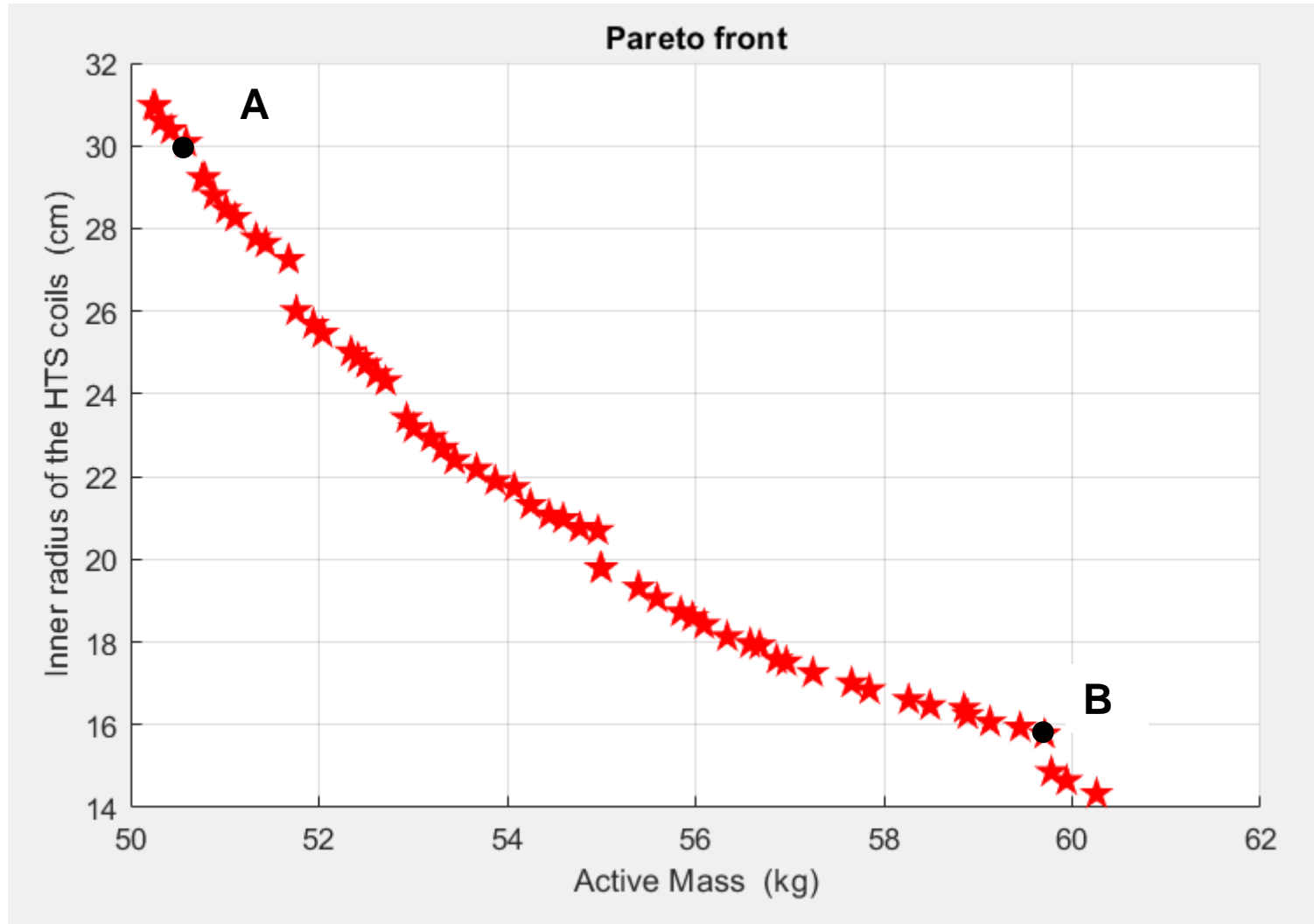

Multi-objective Design Optimization: Results A and B

Variable	Number	Lower	Upper	A	B
p	Pole-pairs number (integer)	1	10	8	4
R ₁	Inner radius of the rotor (cm)	10	40	30.1	15.8
a	Thickness rotor yoke (cm)	0	0	0	0
b	Thickness HTS winding (cm)	0.5	2	1.2	2.1
d	Thickness stator winding (cm)	0.5	5	1.17	1.84
e	2 nd air-gap thickness (cm)	0	0	0	0
f	Thickness stator yoke (cm)	0	0	0	0
L	Axial length (cm)	20	50	30.2	33.3
α	Outer opening HTS coils	0	1	0.99	0.99
β	Inner opening HTS coils	0.1	1	0.413	0.427
v	Opening of the stator coils	0.5	1	0.652	0.747
Mass	Activ mass, windings (kg)			50.6	59.7
R _{ext}	External radius (cm)			33.4	20.7
PTM	Power to Mass ratio (kW/kg)			59.3	50.2

Multi-objective Design Optimization: Pareto front ($J_c = 200 \text{ A/mm}^2$)

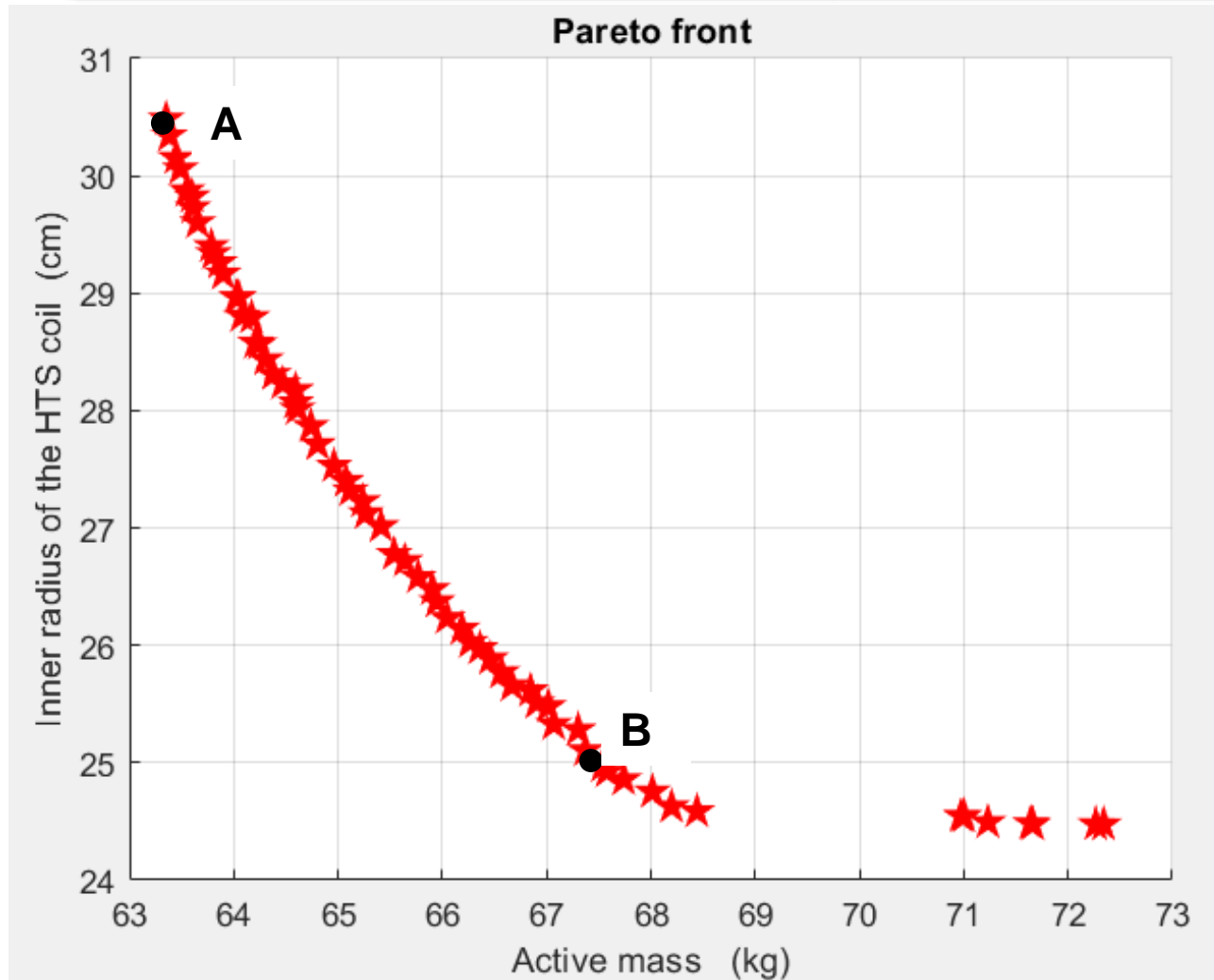

Variable	A	B
p	7	7
R_1	30.5	24.9
a	0	0
b	1.25	1.49
d	1.45	1.45
e	0	0
f	0	0
L	24.7	28.5
α	0.99	0.99
β	0.298	0.305
v	0.783	0.948
Mass	63.4	67.6
R_{ext}	34.2	28.9
PTM	47.3	44.4

- ◆ $J_c=300\text{A/mm}^2$ and $R_2 = 25\text{cm} \rightarrow M = 52.5\text{kg}$, PTM = 57 kW/kg
- ◆ $J_c=200\text{A/mm}^2$ and $R_2 = 25\text{cm} \rightarrow M = 67.6\text{kg}$, PTM = 44 kW/kg

Design Optimization with iron yoke

We have to limit the maximal value of the flux density in the stator and rotor yokes around the knee point of the B(H) characteristic (we have the analytical expression of the flux density in the yokes), if not the model will be not valid.....

Supplementary constraint : $B_{\text{yoke}} < B_{\text{knee}}$ (around 1,6T)

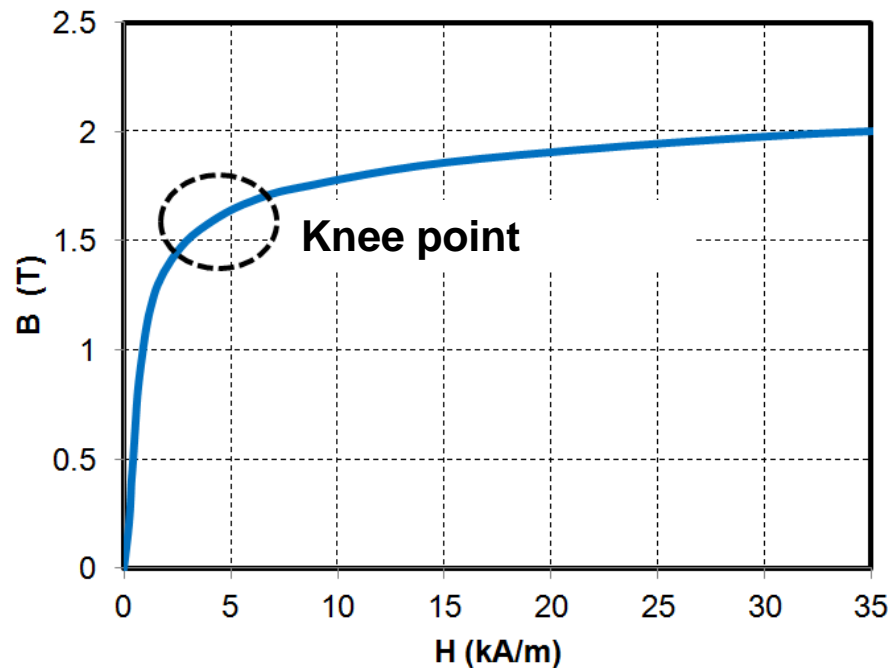

**To do..... Further results are expected
Is iron necessary if PTM is the objective, not sure????**



THANK YOU !