



**HAL**  
open science

## Metric Dimension Parameterized by Treewidth

Edouard Bonnet, Nidhi Purohit

► **To cite this version:**

Edouard Bonnet, Nidhi Purohit. Metric Dimension Parameterized by Treewidth. IPEC 2019, Sep 2019, Munich, Germany. hal-03014920

**HAL Id: hal-03014920**

**<https://hal.science/hal-03014920>**

Submitted on 19 Nov 2020

**HAL** is a multi-disciplinary open access archive for the deposit and dissemination of scientific research documents, whether they are published or not. The documents may come from teaching and research institutions in France or abroad, or from public or private research centers.

L'archive ouverte pluridisciplinaire **HAL**, est destinée au dépôt et à la diffusion de documents scientifiques de niveau recherche, publiés ou non, émanant des établissements d'enseignement et de recherche français ou étrangers, des laboratoires publics ou privés.

# Metric Dimension Parameterized by Treewidth

Édouard Bonnet 

Univ Lyon, CNRS, ENS de Lyon, Université Claude Bernard Lyon 1, LIP UMR5668, France  
edouard.bonnet@ens-lyon.fr

Nidhi Purohit 

Univ Lyon, CNRS, ENS de Lyon, Université Claude Bernard Lyon 1, LIP UMR5668, France  
nidhi.purohit@ens-lyon.fr

---

## Abstract

A resolving set  $S$  of a graph  $G$  is a subset of its vertices such that no two vertices of  $G$  have the same distance vector to  $S$ . The METRIC DIMENSION problem asks for a resolving set of minimum size, and in its decision form, a resolving set of size at most some specified integer. This problem is NP-complete, and remains so in very restricted classes of graphs. It is also W[2]-complete with respect to the size of the solution. METRIC DIMENSION has proven elusive on graphs of bounded treewidth. On the algorithmic side, a polytime algorithm is known for trees, and even for outerplanar graphs, but the general case of treewidth at most two is open. On the complexity side, no parameterized hardness is known. This has led several papers on the topic to ask for the parameterized complexity of METRIC DIMENSION with respect to treewidth.

We provide a first answer to the question. We show that METRIC DIMENSION parameterized by the treewidth of the input graph is W[1]-hard. More refinedly we prove that, unless the Exponential Time Hypothesis fails, there is no algorithm solving METRIC DIMENSION in time  $f(\text{pw})n^{o(\text{pw})}$  on  $n$ -vertex graphs of constant degree, with  $\text{pw}$  the pathwidth of the input graph, and  $f$  any computable function. This is in stark contrast with an FPT algorithm of Belmonte et al. [SIAM J. Discrete Math. '17] with respect to the combined parameter  $\text{tl} + \Delta$ , where  $\text{tl}$  is the tree-length and  $\Delta$  the maximum-degree of the input graph.

**2012 ACM Subject Classification** Theory of computation → Graph algorithms analysis; Theory of computation → Fixed parameter tractability

**Keywords and phrases** Metric Dimension, Treewidth, Parameterized Hardness

**Digital Object Identifier** 10.4230/LIPIcs.IPEC.2019.5

**Related Version** A full version of the paper is available at <https://arxiv.org/abs/1907.08093>.

## 1 Introduction

The METRIC DIMENSION problem has been introduced in the 1970s independently by Slater [22] and by Harary and Melter [13]. Given a graph  $G$  and an integer  $k$ , METRIC DIMENSION asks for a subset  $S$  of vertices of  $G$  of size at most  $k$  such that every vertex of  $G$  is uniquely determined by its distances to the vertices of  $S$ . Such a set  $S$  is called a *resolving set*, and a resolving set of minimum-cardinality is called a *metric basis*. The metric dimension of graphs finds application in various areas including network verification [2], chemistry [4], and robot navigation [18].

METRIC DIMENSION is an entry of the celebrated book on intractability by Garey and Johnson [12] where the authors show that it is NP-complete. In fact METRIC DIMENSION remains NP-complete in many restricted classes of graphs such as planar graphs [6], split, bipartite, co-bipartite graphs, and line graphs of bipartite graphs [9], interval graphs of diameter two [11], permutation graphs of diameter two [11], and in a subclass of unit disk graphs [16]. Furthermore METRIC DIMENSION cannot be solved in subexponential-time unless 3-SAT can [1]. On the positive side, the problem is polynomial-time solvable on trees [22, 13, 18]. Diaz et al. [6] generalize this result to outerplanar graphs. Fernau et al. [10]



© Édouard Bonnet and Nidhi Purohit;  
licensed under Creative Commons License CC-BY

14th International Symposium on Parameterized and Exact Computation (IPEC 2019).

Editors: Bart M. P. Jansen and Jan Arne Telle; Article No. 5; pp. 5:1–5:15

Leibniz International Proceedings in Informatics



LIPICs Schloss Dagstuhl – Leibniz-Zentrum für Informatik, Dagstuhl Publishing, Germany

give a polynomial-time algorithm on chain graphs. Epstein et al. [9] show that METRIC DIMENSION (and even its vertex-weighted variant) can be solved in polynomial time on co-graphs and forests augmented by a constant number of edges. Hoffmann et al. [15] obtain a linear algorithm on cactus block graphs.

Hartung and Nichterlein [14] prove that METRIC DIMENSION is W[2]-complete (parameterized by the size of the solution  $k$ ) even on subcubic graphs. Therefore an FPT algorithm solving the problem is unlikely. However Foucaud et al. [11] give an FPT algorithm with respect to  $k$  on interval graphs. This result is later generalized by Belmonte et al. [3] who obtain an FPT algorithm with respect to  $tl + \Delta$  (where  $tl$  is the tree-length and  $\Delta$  is the maximum-degree of the input graph), implying one for parameter  $tl + k$ . Indeed interval graphs, and even chordal graphs, have constant tree-length. Hartung and Nichterlein [14] presents an FPT algorithm parameterized by the vertex cover number, Eppstein [8], by the max leaf number, and Belmonte et al. [3], by the modular-width (a larger parameter than clique-width).

The complexity of METRIC DIMENSION parameterized by treewidth is quite elusive. It is discussed [8] or raised as an open problem in several papers [3, 6]. On the one hand, it was not known, prior to our paper, if this problem is W[1]-hard. On the other hand, the complexity of METRIC DIMENSION in graphs of treewidth at most two is still an open question.

## 1.1 Our contribution

We settle the parameterized complexity of METRIC DIMENSION with respect to treewidth. We show that this problem is W[1]-hard, and we rule out, under the Exponential Time Hypothesis (ETH), an algorithm running in  $f(\text{tw})|V(G)|^{o(\text{tw})}$ , where  $G$  is the input graph,  $\text{tw}$  its treewidth, and  $f$  any computable function. Our reduction even shows that an algorithm in time  $f(\text{pw})|V(G)|^{o(\text{pw})}$  is unlikely on constant-degree graphs, for the larger parameter pathwidth  $\text{pw}$ . This is in stark contrast with the FPT algorithm of Belmonte et al. [3] for the parameter  $tl + \Delta$  where  $tl$  is the tree-length and  $\Delta$  is the maximum-degree of the graph. We observe that this readily gives an FPT algorithm for  $\text{ctw} + \Delta$  where  $\text{ctw}$  is the connected treewidth, since  $\text{ctw} \geq tl$ . This unravels an interesting behavior of METRIC DIMENSION, at least on bounded-degree graphs: usual tree-decompositions are not enough for efficient solving. Instead one needs tree-decompositions with an additional guarantee that the vertices of a same bag are at a bounded distance from each other.

As our construction is quite technical, we chose to introduce an intermediate problem dubbed  $k$ -MULTICOLORED RESOLVING SET in the reduction from  $k$ -MULTICOLORED INDEPENDENT SET to METRIC DIMENSION. The first half of the reduction, from  $k$ -MULTICOLORED INDEPENDENT SET to  $k$ -MULTICOLORED RESOLVING SET, follows a generic and standard recipe to design parameterized hardness with respect to treewidth. The main difficulty is to design an effective *propagation gadget* with a constant-size left-right cut. The second half brings some new local attachments to the produced graph, to bridge the gap between  $k$ -MULTICOLORED RESOLVING SET and METRIC DIMENSION. Along the way, we introduce a number of gadgets: edge, propagation, forced set, forced vertex. They are quite streamlined and effective. Therefore, we believe these building blocks may help in designing new reductions for METRIC DIMENSION.

## 1.2 Organization of the paper

In Section 2 we introduce the definitions, notations, and terminology used throughout the paper. In Section 3 we present the high-level ideas to establish our result. We define the  $k$ -MULTICOLORED RESOLVING SET problem which serves as an intermediate step for our reduction. In Section 4 we design a parameterized reduction from the W[1]-complete  $k$ -MULTICOLORED INDEPENDENT SET to  $k$ -MULTICOLORED RESOLVING SET parameterized by treewidth. In Section 5 we show how to transform the produced instances of  $k$ -MULTICOLORED RESOLVING SET to METRIC DIMENSION-instances (while maintaining bounded treewidth). Due to space constraints, the proofs of lemmas marked with a star are deferred to the long version (in appendix).

## 2 Preliminaries

We denote by  $[i, j]$  the set of integers  $\{i, i + 1, \dots, j - 1, j\}$ , and by  $[i]$  the set of integers  $[1, i]$ . If  $\mathcal{X}$  is a set of sets, we denote by  $\cup \mathcal{X}$  the union of them.

### 2.1 Graph notations

All our graphs are undirected and simple (no multiple edge nor self-loop). We denote by  $V(G)$ , respectively  $E(G)$ , the set of vertices, respectively of edges, of the graph  $G$ . For  $S \subseteq V(G)$ , we denote the *open neighborhood* (or simply *neighborhood*) of  $S$  by  $N_G(S)$ , i.e., the set of neighbors of  $S$  deprived of  $S$ , and the *closed neighborhood* of  $S$  by  $N_G[S]$ , i.e., the set  $N_G(S) \cup S$ . For singletons, we simplify  $N_G(\{v\})$  into  $N_G(v)$ , and  $N_G[\{v\}]$  into  $N_G[v]$ . We denote by  $G[S]$  the subgraph of  $G$  induced by  $S$ , and  $G - S := G[V(G) \setminus S]$ . For  $S \subseteq V(G)$  we denote by  $\bar{S}$  the complement  $V(G) \setminus S$ . For  $A, B \subseteq V(G)$ ,  $E(A, B)$  denotes the set of edges in  $E(G)$  with one endpoint in  $A$  and the other one in  $B$ .

The length of a path in an unweighted graph is simply the number of edges of the path. For two vertices  $u, v \in V(G)$ , we denote by  $\text{dist}_G(u, v)$ , the distance between  $u$  and  $v$  in  $G$ , that is the length of the shortest path between  $u$  and  $v$ . The diameter of a graph is the longest distance between a pair of its vertices. The diameter of a subset  $S \subseteq V(G)$ , denoted by  $\text{diam}_G(S)$ , is the longest distance between a pair of vertices in  $S$ . Note that the distance is taken in  $G$ , *not* in  $G[S]$ . In particular, when  $G$  is connected,  $\text{diam}_G(S)$  is finite for every  $S$ . A *pendant* vertex is a vertex with degree one. A vertex  $u$  is *pendant to*  $v$  if  $v$  is the only neighbor of  $u$ . Two distinct vertices  $u, v$  such that  $N(u) = N(v)$  are called *false twins*, and *true twins* if  $N[u] = N[v]$ . In particular, true twins are adjacent. In all the above notations with a subscript, we omit it whenever the graph is implicit from the context.

### 2.2 Exponential Time Hypothesis, FPT reductions, and W[1]-hardness

The *Exponential Time Hypothesis* (ETH) is a conjecture by Impagliazzo et al. [17] asserting that there is no  $2^{o(n)}$ -time algorithm for 3-SAT on instances with  $n$  variables. Lokshtanov et al. [20] survey conditional lower bounds under the ETH.

A standard use of an FPT reduction is to derive conditional lower bounds: if a problem  $(\Pi, \kappa)$  is thought not to admit an FPT algorithm, then an FPT reduction from  $(\Pi, \kappa)$  to  $(\Pi', \kappa')$  indicates that  $(\Pi', \kappa')$  is also unlikely to admit an FPT algorithm. We refer the reader to the textbooks [7, 5] for a formal definition of W[1]-hardness. For the purpose of this paper, we will just state that W[1]-hard are parameterized problems that are unlikely to be FPT, and that the following problem is W[1]-complete even when all the  $V_i$  have the same number of elements, say  $t$  (see for instance [21]).

$k$ -MULTICOLORED INDEPENDENT SET ( $k$ -MIS) **Parameter:**  $k$   
**Input:** An undirected graph  $G$ , an integer  $k$ , and  $(V_1, \dots, V_k)$  a partition of  $V(G)$ .  
**Question:** Is there a set  $I \subseteq V(G)$  such that  $|I \cap V_i| = 1$  for every  $i \in [k]$ , and  $G[I]$  is edgeless?

Every parameterized problem that  $k$ -MULTICOLORED INDEPENDENT SET FPT-reduces to is  $W[1]$ -hard. Our paper is thus devoted to designing an FPT reduction from  $k$ -MULTICOLORED INDEPENDENT SET to METRIC DIMENSION parameterized by  $tw$ . Let us observe that the ETH implies that one (equivalently, every)  $W[1]$ -hard problem is not in the class of problems solvable in FPT time ( $FPT \neq W[1]$ ). Thus if we admit that there is no subexponential algorithm solving 3-SAT, then  $k$ -MULTICOLORED INDEPENDENT SET is not solvable in time  $f(k)|V(G)|^{O(1)}$ . Actually under this stronger assumption,  $k$ -MULTICOLORED INDEPENDENT SET is not solvable in time  $f(k)|V(G)|^{o(k)}$ . A concise proof of that fact can be found in the survey on the consequences of ETH [20].

### 2.3 Metric dimension, resolved pairs, distinguished vertices

A pair of vertices  $\{u, v\} \subseteq V(G)$  is said to be *resolved* by a set  $S$  if there is a vertex  $w \in S$  such that  $\text{dist}(w, u) \neq \text{dist}(w, v)$ . A vertex  $u$  is said to be *distinguished* by a set  $S$  if for any  $w \in V(G) \setminus \{u\}$ , there is a vertex  $v \in S$  such that  $\text{dist}(v, u) \neq \text{dist}(v, w)$ . A *resolving set* of a graph  $G$  is a set  $S \subseteq V(G)$  such that every two distinct vertices  $u, v \in V(G)$  are resolved by  $S$ . Equivalently, a resolving set is a set  $S$  such that every vertex of  $G$  is distinguished by  $S$ . Then METRIC DIMENSION asks for a resolving set of size at most some threshold  $k$ . Note that a resolving set of minimum size is sometimes called a *metric basis* for  $G$ .

METRIC DIMENSION (MD) **Parameter:**  $tw(G)$   
**Input:** An undirected graph  $G$  and an integer  $k$ .  
**Question:** Does  $G$  admit a resolving set of size at most  $k$ ?

Here we anticipate on the fact that we will mainly consider METRIC DIMENSION parameterized by treewidth. Henceforth we sometimes use the notation  $\Pi/tw$  to emphasize that  $\Pi$  is not parameterized by the natural parameter (size of the resolving set) but by the treewidth of the input graph.

## 3 Outline of the $W[1]$ -hardness proof of Metric Dimension/ $tw$

We will show the following.

► **Theorem 1.** *Unless the ETH fails, there is no computable function  $f$  such that METRIC DIMENSION can be solved in time  $f(pw)n^{o(pw)}$  on constant-degree  $n$ -vertex graphs.*

We first prove that the following generalized version of METRIC DIMENSION is  $W[1]$ -hard.

$k$ -MULTICOLORED RESOLVING SET ( $k$ -MRS) **Parameter:**  $tw(G)$   
**Input:** An undirected graph  $G$ , an integer  $k$ , a set  $\mathcal{X}$  of  $q$  disjoint subsets of  $V(G)$ :  $X_1, \dots, X_q$ , and a set  $\mathcal{P}$  of pairs of vertices of  $G$ :  $\{x_1, y_1\}, \dots, \{x_h, y_h\}$ .  
**Question:** Is there a set  $S \subseteq V(G)$  of size  $q$  such that  
 ■ (i) for every  $i \in [q]$ ,  $|S \cap X_i| = 1$ , and  
 ■ (ii) for every  $p \in [h]$ , there is an  $s \in S$  satisfying  $\text{dist}_G(s, x_p) \neq \text{dist}_G(s, y_p)$ ?

In words, in this generalized version the resolving set is made by picking exactly one vertex in each set of  $\mathcal{X}$ , and not all the pairs should be resolved but only the ones in a prescribed set  $\mathcal{P}$ . We call *critical pair* a pair of  $\mathcal{P}$ . In the context of  $k$ -MULTICOLORED

RESOLVING SET, we call *legal set* a set which satisfies the former condition, and *resolving set* a set which satisfies the latter. Thus a solution for  $k$ -MULTICOLORED RESOLVING SET is a legal resolving set.

The reduction from  $k$ -MULTICOLORED INDEPENDENT SET starts with a well-established trick to show parameterized hardness by treewidth. We create  $m$  “empty copies” of the  $k$ -MIS-instance  $(G, k, (V_1, \dots, V_k))$ , where  $m := |E(G)|$  and  $t := |V_i|$ . We force exactly one vertex in each color class of each copy to be in the resolving set, using the set  $\mathcal{X}$ . In each copy, we introduce an edge gadget for a single (distinct) edge of  $G$ . Encoding an edge of  $k$ -MIS in the  $k$ -MRS-instance is fairly simple: we build a pair (of  $\mathcal{P}$ ) which is resolved by every choice but the one *selecting both its endpoints* in the resolving set. We now need to force a *consistent choice of the vertex chosen in  $V_i$*  over all the copies. We thus design a propagation gadget. A crucial property of the propagation gadget, for the pathwidth of the constructed graph to be bounded, is that it admits a cut of size  $O(k)$  disconnecting one copy from the other. Encoding a choice in  $V_i$  in the distances to four special vertices, called *gates*, we manage to build such a gadget with constant-size “left-right” separator per color class. This works by introducing  $t$  pairs (of  $\mathcal{P}$ ) which are resolved by the south-west and north-east gates but not by the south-east and north-west ones. Then we link the vertices of a copy of  $V_i$  in a way that the higher their index, the more pairs they resolve in the propagation gadget to their left, and the fewer pairs they resolve in the propagation gadget to their right.

We then turn to the actual METRIC DIMENSION problem. We design a gadget which simulates requirement (i) by forcing a vertex of a specific set  $X$  in the resolving set. This works by introducing two pairs that are only resolved by vertices of  $X$ . We attach this new gadget, called *forcing set* gadget, to all the  $k$  color classes of the  $m$  copies. Finally we have to make sure that a candidate solution resolves all the pairs, and not only the ones prescribed by  $\mathcal{P}$ . For that we attach two adjacent “pendant” vertices to strategically chosen vertices. One of these two vertices have to be in the resolving set since they are true twins, hence not resolved by any other vertex. Then everything is as if the unique common neighbor  $v$  of the true twins was added to the resolving set. Therefore we can perform this operation as long as  $v$  does not resolve any of the pairs of  $\mathcal{P}$ .

To facilitate the task of the reader, henceforth we stick to the following conventions:

- Index  $i \in [k]$  ranges over the  $k$  rows of the (G)MD-instance or color classes of  $k$ -MIS.
- Index  $j \in [m]$  ranges over the  $m$  columns of the (G)MD-instance or edges of  $k$ -MIS.
- Index  $\gamma \in [t]$ , ranges over the  $t$  vertices of a color class.

We invite the reader to look up Table 1 when in doubt about a notation/symbol relative to the construction.

## 4 Parameterized hardness of $k$ -Multicolored Resolving Set/tw

In this section, we give an FPT reduction from the  $W[1]$ -complete  $k$ -MULTICOLORED INDEPENDENT SET to  $k$ -MULTICOLORED RESOLVING SET parameterized by treewidth. More precisely, given a  $k$ -MULTICOLORED INDEPENDENT SET-instance  $(G, k, (V_1, \dots, V_k))$  we produce in polynomial-time an equivalent  $k$ -MULTICOLORED RESOLVING SET-instance  $(G', k', \mathcal{X}, \mathcal{P})$  where  $G'$  has pathwidth (hence treewidth)  $O(k)$ .

### 4.1 Construction

Let  $(G, k, (V_1, \dots, V_k))$  be an instance of  $k$ -MULTICOLORED INDEPENDENT SET where  $(V_1, \dots, V_k)$  is a partition of  $V(G)$  and  $V_i := \{v_{i,\gamma} \mid 1 \leq \gamma \leq t\}$ . We arbitrarily number  $e_1, \dots, e_j, \dots, e_m$  the  $m$  edges of  $G$ .

### 4.1.1 Overall picture

We start with a high-level description of the  $k$ -MRS-instance  $(G', k', \mathcal{X}, \mathcal{P})$ . For each color class  $V_i$ , we introduce  $m$  copies  $V_i^1, \dots, V_i^j, \dots, V_i^m$  of a *selector gadget* to  $G'$ . Each set  $V_i^j$  is added to  $\mathcal{X}$ , so a solution has to pick exactly one vertex within each selector gadget. One can imagine the vertex-sets  $V_i^1, \dots, V_i^m$  to be aligned on the  $i$ -th row, with  $V_i^j$  occupying the  $j$ -th column (see Figure 1). Each  $V_i^j$  has  $t$  vertices denoted by  $v_{i,1}^j, v_{i,2}^j, \dots, v_{i,t}^j$ , where each  $v_{i,\gamma}^j$  “corresponds” to  $v_{i,\gamma} \in V_i$ . We make  $v_{i,1}^j v_{i,2}^j \dots v_{i,t}^j$  a path with  $t - 1$  edges.

For each edge  $e_j \in E(G)$ , we insert an *edge gadget*  $\mathcal{G}(e_j)$  containing a pair of vertices  $\{c_j, c'_j\}$  that we add to  $\mathcal{P}$ . Gadget  $\mathcal{G}(e_j)$  is attached to  $V_i^j$  and  $V_{i'}^{j'}$ , where  $e_j \in E(V_i, V_{i'})$ . The edge gadget is designed in a way that the only legal sets that do *not* resolve  $\{c_j, c'_j\}$  are the ones that precisely pick  $v_{i,\gamma}^j \in V_i^j$  and  $v_{i',\gamma'}^{j'} \in V_{i'}^{j'}$  such that  $e_j = v_{i,\gamma} v_{i',\gamma'}$ . We add a *propagation gadget*  $P_i^{j,j+1}$  between two consecutive copies  $V_i^j$  and  $V_i^{j+1}$ , where the indices in the superscript are taken modulo  $m$ . The role of the propagation gadget is to ensure that the choices in each  $V_i^j$  ( $j \in [m]$ ) corresponds to the same vertex in  $V_i$ .

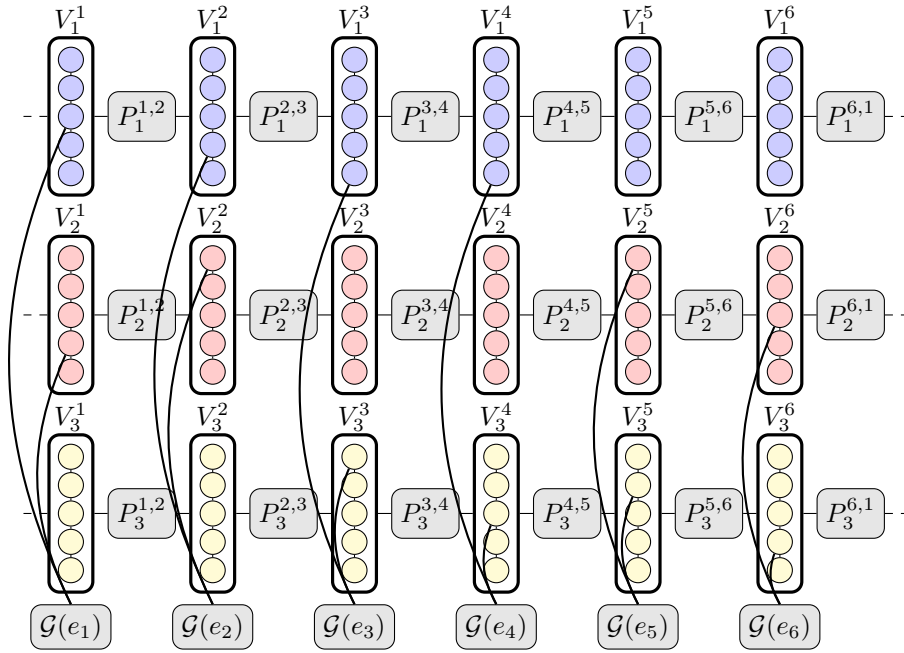

■ **Figure 1** The overall picture with  $k = 3$  color classes,  $t = 5$  vertices per color class,  $m = 6$  edges,  $e_1 = v_{1,3}v_{2,4}$ ,  $e_2 = v_{1,4}v_{2,1}$ ,  $e_3 = v_{1,5}v_{3,1}$ , etc. The dashed lines on the left and right symbolize that the construction is cylindrical.

The intuitive idea of the reduction is the following. We say that a vertex of  $G'$  is *selected* if it is put in the resolving set of  $G'$ , a tentative solution. The propagation gadget  $P_i^{j,j+1}$  ensures a consistent choice among the  $m$  copies  $V_i^1, \dots, V_i^m$ . The edge gadget ensures that the selected vertices of  $G'$  correspond to an independent set in the original graph  $G$ . If both the endpoints of an edge  $e_j$  are selected, then the pair  $\{c_j, c'_j\}$  is not resolved. We now detail the construction.

### 4.1.2 Selector gadget

For each  $i \in [k]$  and  $j \in [m]$ , we add to  $G'$  a path on  $t - 1$  edges  $v_{i,1}^j, v_{i,2}^j, \dots, v_{i,t}^j$ , and denote this set of vertices by  $V_i^j$ . Each  $v_{i,\gamma}^j$  corresponds to  $v_{i,\gamma} \in V_i$ . We call  $j$ -th column the set  $\bigcup_{i \in [k]} V_i^j$ , and  $i$ -th row, the set  $\bigcup_{j \in [m]} V_i^j$ . We set  $\mathcal{X} := \{V_i^j\}_{i \in [k], j \in [m]}$ . By definition of  $k$ -MULTICOLORED RESOLVING SET, a solution  $S$  has to satisfy that for every  $i \in [k], j \in [m]$ ,  $|S \cap V_i^j| = 1$ . We call *legal set* a set  $S$  of size  $k' = km$  that satisfies this property. We call *consistent set* a legal set  $S$  which takes the “same” vertex in each row, that is, for every  $i \in [k]$ , for every pair  $(v_{i,\gamma}^j, v_{i,\gamma'}^j) \in (S \cap V_i^j) \times (S \cap V_i^j)$ , then  $\gamma = \gamma'$ .

### 4.1.3 Edge gadget

For each edge  $e_j = v_{i,\gamma} v_{i',\gamma'} \in E(G)$ , we add an edge gadget  $\mathcal{G}(e_j)$  in the  $j$ -th column of  $G'$ .  $\mathcal{G}(e_j)$  consists of a path on three vertices:  $c_j g_j c'_j$ . The pair  $\{c_j, c'_j\}$  is added to the list of critical pairs  $\mathcal{P}$ . We link both  $v_{i,\gamma}^j$  and  $v_{i',\gamma'}^j$  to  $g_j$  by a private path<sup>1</sup> of length  $t + 2$ . We link the at least two and at most four vertices  $v_{i,\gamma-1}^j, v_{i,\gamma+1}^j, v_{i',\gamma'-1}^j, v_{i',\gamma'+1}^j$  (whenever they exist) to  $c_j$  by a private path of length  $t + 2$ . This defines at most six paths from  $V_i^j \cup V_{i'}^j$  to  $\mathcal{G}(e_j)$ . Let us denote by  $W_j$  the at most six endpoints of these paths in  $V_i^j \cup V_{i'}^j$ . For each  $v \in W_j$ , we denote by  $P(v, j)$  the path from  $v$  to  $\mathcal{G}(e_j)$ . We set  $E_i^j := \bigcup_{v \in W_j \cap V_i^j} P(v, j)$  and  $E_{i'}^j := \bigcup_{v \in W_j \cap V_{i'}^j} P(v, j)$ . We denote by  $X_j$  the set of the at most six neighbors of  $W_j$  on the paths to  $\mathcal{G}(e_j)$ . Henceforth we may refer to the vertices in some  $X_j$  as the *cyan vertices*. Individually we denote by  $e_{i,\gamma}^j$  the cyan vertex neighbor of  $v_{i,\gamma}^j$  in  $P(v_{i,\gamma}^j, j)$ . We observe that for fixed  $i$  and  $j$ ,  $e_{i,\gamma}^j$  exists for at most three values of  $\gamma$ . We add an edge between two cyan vertices if their respective neighbors in  $V_i^j$  are also linked by an edge (or equivalently, if they have consecutive “indices  $\gamma$ ”). These extra edges are useless in the  $k$ -MRS-instance, but will turn out useful in the MD-instance. See Figure 2 for an illustration of the edge gadget.

The rest of the construction will preserve that for every  $v \in (V_i^j \cup V_{i'}^j) \setminus \{v_{i,\gamma}^j, v_{i',\gamma'}^j\}$ ,  $\text{dist}(v, c'_j) = \text{dist}(v, c_j) + 2$ , and for each  $v \in \{v_{i,\gamma}^j, v_{i',\gamma'}^j\}$ ,  $\text{dist}(v, c_j) = \text{dist}(v, g_j) + 1 = \text{dist}(v, c'_j)$ . In other words, the only two vertices of  $V_i^j \cup V_{i'}^j$  not resolving the critical pair  $\{c_j, c'_j\}$  are  $v_{i,\gamma}^j$  and  $v_{i',\gamma'}^j$ , corresponding to the endpoints of  $e_j$ .

### 4.1.4 Propagation gadget

Between each pair  $(V_i^j, V_i^{j+1})$ , where  $j + 1$  is taken modulo  $m$ , we insert an identical copy of the propagation gadget, and we denote it by  $P_i^{j,j+1}$ . It ensures that if the vertex  $v_{i,\gamma}^j$  is in a legal resolving set  $S$ , then the vertex of  $S \cap V_i^{j+1}$  should be some  $v_{i,\gamma'}^{j+1}$  with  $\gamma \leq \gamma'$ . The cylindricity of the construction and the fact that exactly one vertex of  $V_i^j$  is selected, will therefore impose that the set  $S$  is consistent.

$P_i^{j,j+1}$  comprises four vertices  $\text{sw}_i^j, \text{se}_i^j, \text{nw}_i^j, \text{ne}_i^j$ , called *gates*, and a set  $A_i^j$  of  $2t$  vertices  $a_{i,1}^j, \dots, a_{i,t}^j, \alpha_{i,1}^j, \dots, \alpha_{i,t}^j$ . We make both  $a_{i,1}^j a_{i,2}^j \dots a_{i,t}^j$  and  $\alpha_{i,1}^j \alpha_{i,2}^j \dots \alpha_{i,t}^j$  a path with  $t - 1$  edges. For each  $\gamma \in [t]$ , we add the pair  $\{a_{i,\gamma}^j, \alpha_{i,\gamma}^j\}$  to the set of critical pairs  $\mathcal{P}$ . Removing the gates disconnects  $A_i^j$  from the rest of the graph.

We now describe how we link the gates to  $V_i^j, V_i^{j+1}$ , and  $A_i^j$ . We link  $v_{i,1}^j$  (the “top” vertex of  $V_i^j$ ) to  $\text{sw}_i^j$  and  $v_{i,t}^j$  (the “bottom” vertex of  $V_i^j$ ) to  $\text{nw}_i^j$  both by a path of length 2.

<sup>1</sup> We use the expression *private path* to emphasize that the different sources get a pairwise internally vertex-disjoint path to the target.



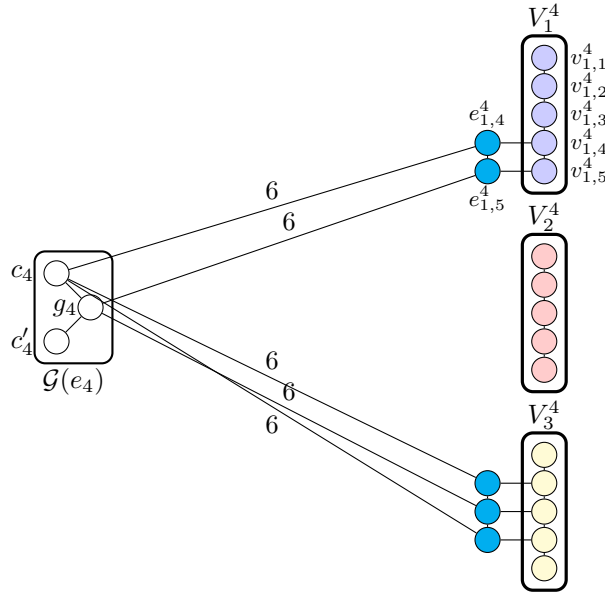

■ **Figure 2** The edge gadget  $\mathcal{G}(e_4)$  with  $e_4 = v_{1,5}v_{3,3}$ . Weighted edges are short-hands for subdivisions of the corresponding length. The edges between the cyan vertices will not be useful for the  $k$ -MRS-instance, but will later simplify the construction of the MD-instance.

We also link  $v_{i,1}^{j+1}$  to  $se_i^j$  by a path of length 3, and  $v_{i,t}^{j+1}$  to  $ne_i^j$  by a path of length 2. Then we make  $nw_i^j$  adjacent to  $a_{i,1}^j$  and  $\alpha_{i,1}^j$ , while we make  $ne_i^j$  adjacent to  $\alpha_{i,1}^j$  only. We make  $se_i^j$  adjacent to  $a_{i,t}^j$  and  $\alpha_{i,t}^j$ , while we make  $sw_i^j$  adjacent to  $a_{i,t}^j$  only. Finally, we add an edge between  $ne_i^j$  and  $nw_i^j$ , and between  $sw_i^j$  and  $se_i^j$ . See Figure 3 for an illustration of the propagation gadget  $P_i^{j,j+1}$  with  $t = 5$ .

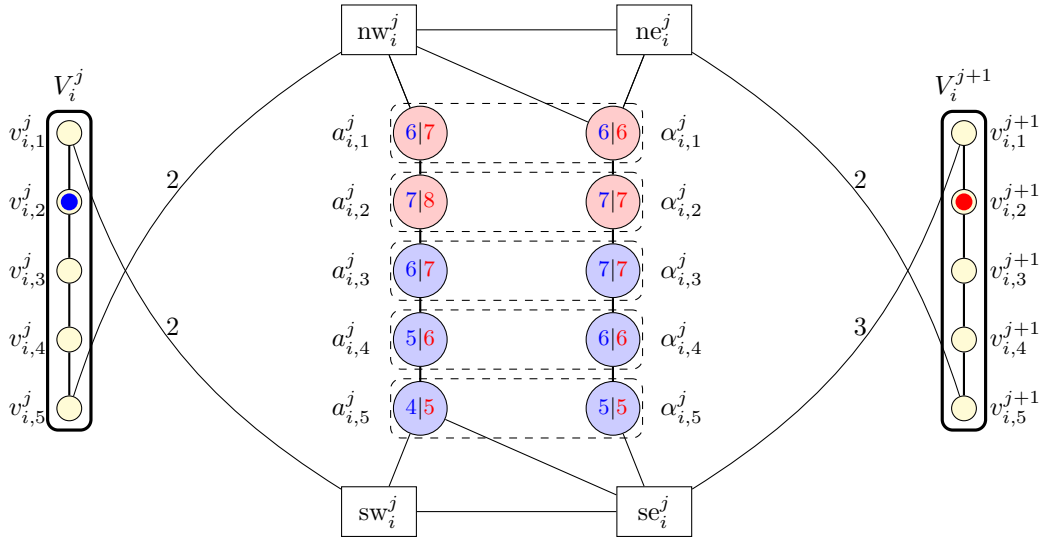

■ **Figure 3** The propagation gadget  $P_i^{j,j+1}$ . The critical pairs  $\{a_{i,\gamma}^j, \alpha_{i,\gamma}^j\}$  are surrounded by thin dashed lines. The blue (resp. red) integer on a vertex of  $A_i^j$  is its distance to the blue (resp. red) vertex in  $V_i^j$  (resp.  $V_i^{j+1}$ ). Note that the blue vertex distinguishes the critical pairs below it, while the red vertex distinguishes critical pairs at its level or above.

Let us motivate the gadget  $P_i^{j,j+1}$ . One can observe that the gates  $ne_i^j$  and  $sw_i^j$  resolve the critical pairs of the propagation gadget, while the gates  $nw_i^j$  and  $se_i^j$  do not. Consider that the vertex added to the resolving set in  $V_i^j$  is  $v_{i,\gamma}^j$ . Its shortest paths to critical pairs *below* it (that is, with index  $\gamma' > \gamma$ ) go through the gate  $sw_i^j$ , whereas its shortest paths to critical pairs at its level or above (that is, with index  $\gamma' \leq \gamma$ ) go through the gate  $nw_i^j$ . Thus  $v_{i,\gamma}^j$  only resolves the critical pairs  $\{\alpha_{i,\gamma'}^j, \alpha_{i,\gamma'}^j\}$  with  $\gamma' > \gamma$ . On the contrary, the vertex of the resolving set in  $V_i^{j+1}$  only resolves the critical pairs  $\{\alpha_{i,\gamma'}^j, \alpha_{i,\gamma'}^j\}$  at its level or above. This will force that its level is  $\gamma$  or below. Hence the vertices of the resolving in  $V_i^j$  and  $V_i^{j+1}$  should be such that  $\gamma' \geq \gamma$ . Since there is also a propagation gadget between  $V_i^m$  and  $V_i^1$ , this circular chain of inequalities forces a global equality.

### 4.1.5 Wrapping up

We put the pieces together as described in the previous subsections. At this point, it is convenient to give names to the neighbors of  $V_i^j$  in the propagation gadgets  $P_i^{j-1,j}$  and  $P_i^{j,j+1}$ . We may refer to them as *blue vertices* (as they appear in Figure 4). We denote by  $tl_i^j$  the neighbor of  $v_{i,1}^j$  in  $P_i^{j-1,j}$ ,  $tr_i^j$ , the neighbor of  $v_{i,1}^j$  in  $P_i^{j,j+1}$ ,  $bl_i^j$ , the neighbor of  $v_{i,t}^j$  in  $P_i^{j-1,j}$ , and  $br_i^j$ , the neighbor of  $v_{i,t}^j$  in  $P_i^{j,j+1}$ . We add the following edges and paths.

For any pair  $i, j$  such that the edge  $e_j$  has an endpoint in  $V_i$ , the vertices  $tl_i^j, tr_i^j, bl_i^j, br_i^j$  are linked to  $g_j$  by a private path of length the distance of their unique neighbor in  $V_i^j$  to  $c_j$ . We add an edge between  $se_i^j$  and  $se_i^{j+1}$ , and between  $nw_i^j$  and  $nw_i^{j+1}$  (where  $j+1$  is modulo  $m$ ). Finally, for every  $e_j \in E(V_i, V_{i'})$ , we add four paths between  $se_i^j, se_{i'}^j, nw_i^j, nw_{i'}^j$  and  $g_j \in \mathcal{G}(e_j)$ . More precisely, for each  $i'' \in \{i, i'\}$ , we add a path from  $g_j$  to  $se_{i''}^j$  of length  $\text{dist}(g_j, sw_{i''}^j) - 4$ , and a path from  $g_j$  to  $nw_{i''}^j$  of length  $\text{dist}(g_j, nw_{i''}^j) - 4$ . These distances are taken in the graph before we introduced the new paths, and one can observe that the length of these paths is at least  $t$ . This finishes the construction.

## 4.2 Correctness of the reduction

We now check that the reduction is correct. We start with the following technical lemma. If a set  $X$  contains a pair that no vertex of  $N(X)$  (that is  $N[X] \setminus X$ ) resolves, then no vertex outside  $X$  can distinguish the pair.

► **Lemma 2.** *Let  $X$  be a subset of vertices, and  $a, b \in X$  be two distinct vertices. If for every vertex  $v \in N(X)$ ,  $\text{dist}(v, a) = \text{dist}(v, b)$ , then for every vertex  $v \notin X$ ,  $\text{dist}(v, a) = \text{dist}(v, b)$ .*

**Proof.** Let  $v$  be a vertex outside of  $X$ . We further assume that  $v$  is not in  $N(X)$ , otherwise we can already conclude that it does not distinguish  $\{a, b\}$ . A shortest path from  $v$  to  $a$ , has to go through  $N(X)$ . Let  $w_a$  be the first vertex of  $N(X)$  met in this shortest path from  $v$  to  $a$ . Similarly, let  $w_b$  be the first vertex of  $N(X)$  met in a shortest path from  $v$  to  $b$ . Since  $w_a, w_b \in N(X)$ , they satisfy  $\text{dist}(w_a, a) = \text{dist}(w_a, b)$  and  $\text{dist}(w_b, a) = \text{dist}(w_b, b)$ . Then,  $\text{dist}(v, a) \leq \text{dist}(v, w_b) + \text{dist}(w_b, a) = \text{dist}(v, w_b) + \text{dist}(w_b, b) = \text{dist}(v, b)$ , and  $\text{dist}(v, b) \leq \text{dist}(v, w_a) + \text{dist}(w_a, b) = \text{dist}(v, w_a) + \text{dist}(w_a, a) = \text{dist}(v, a)$ . Thus  $\text{dist}(v, a) = \text{dist}(v, b)$ . ◀

We use the previous lemma to show that every vertex of a  $V_i^j$  only resolves critical pairs in gadgets it is attached to. This will be useful in the two subsequent lemmas.

► **Lemma 3** (★). *For any  $i \in [k]$ ,  $j \in [m]$ , and  $v \in V_i^j$ ,  $v$  does not resolve any critical pair outside of  $P_i^{j-1,j}, P_i^{j,j+1}$  (where indices in the superscript are taken modulo  $m$ ), and  $\{c_j, c'_j\}$ . Furthermore, if  $e_j \in E(G)$  has no endpoint in  $V_i \subseteq V(G)$ , then  $v$  does not resolve  $\{c_j, c'_j\}$ .*

The two following lemmas show the equivalences relative to the expected use of the edge and propagation gadgets. They will be useful in Sections 4.2.1 and 4.2.2.

► **Lemma 4** (★). *A legal set  $S$  resolves the critical pair  $\{c_j, c'_j\}$  with  $e_j = v_{i,\gamma}v_{i',\gamma'}$  if and only if the vertex  $v_{i,\gamma_i}^j$  in  $V_i^j \cap S$  and the vertex  $v_{i',\gamma_{i'}}^j$  in  $V_{i'}^j \cap S$  satisfy  $(\gamma, \gamma') \neq (\gamma_i, \gamma_{i'})$ .*

► **Lemma 5** (★). *A legal set  $S$  resolves all the critical pairs of  $P_i^{j,j+1}$  if and only if the vertex  $v_{i,\gamma}^j$  in  $V_i^j \cap S$  and the vertex  $v_{i,\gamma'}^{j+1}$  in  $V_i^{j+1} \cap S$  satisfy  $\gamma \leq \gamma'$ .*

We can now prove the correctness of the reduction. The construction can be computed in polynomial time in  $|V(G)|$ , and  $G'$  itself has size bounded by a polynomial in  $|V(G)|$ . We postpone checking that the pathwidth is bounded by  $O(k)$  to the end of the second step, where we produce an instance of MD whose graph  $G''$  admits  $G'$  as an induced subgraph.

#### 4.2.1 $k$ -Multicolored Independent Set in $G \Rightarrow$ legal resolving set in $G'$

Let  $\{v_{1,\gamma_1}, \dots, v_{k,\gamma_k}\}$  be a  $k$ -multicolored independent set in  $G$ . We claim that  $S := \bigcup_{j \in [m]} \{v_{1,\gamma_1}^j, \dots, v_{k,\gamma_k}^j\}$  is a legal resolving set in  $G'$  (of size  $km$ ). The set  $S$  is legal by construction. Since for every  $i \in [k]$ , and  $j \in [m]$ ,  $v_{i,\gamma_i}^j$  and  $v_{i,\gamma_i}^{j+1}$  are in  $S$  ( $j+1$  is modulo  $m$ ), all the critical pairs in the propagation gadgets are resolved by  $S$ , by Lemma 5. Since  $\{v_{1,\gamma_1}, \dots, v_{k,\gamma_k}\}$  is an independent set in  $G$ , there is no  $e_j = v_{i,\gamma}v_{i',\gamma'} \in E(G)$ , such that  $(\gamma, \gamma') = (\gamma_i, \gamma_{i'})$ . Thus every critical pair  $\{c_j, c'_j\}$  is resolved by  $S$ , by Lemma 4.

#### 4.2.2 Legal resolving set in $G' \Rightarrow k$ -Multicolored Independent Set in $G$

Assume that there is a legal resolving set  $S$  in  $G'$ . For every  $i \in [k]$ , for every  $j \in [m]$ , the vertex  $v_{i,\gamma(i,j)}^j$  in  $V_i^j \cap S$  and the vertex  $v_{i,\gamma(i,j+1)}^{j+1}$  in  $V_i^{j+1} \cap S$  ( $j+1$  is modulo  $m$ ) are such that  $\gamma(i,j) \leq \gamma(i,j+1)$ , by Lemma 5. Thus  $\gamma(i,1) \leq \gamma(i,2) \leq \dots \leq \gamma(i,m-1) \leq \gamma(i,m) \leq \gamma(i,1)$ , and  $\gamma_i := \gamma(i,1) = \gamma(i,2) = \dots = \gamma(i,m-1) = \gamma(i,m)$ . We claim that  $\{v_{1,\gamma_1}, \dots, v_{k,\gamma_k}\}$  is a  $k$ -multicolored independent set in  $G$ . Indeed, there cannot be an edge  $e_j = v_{i,\gamma_i}v_{i',\gamma_{i'}} \in E(G)$ , since otherwise the critical pair  $\{c_j, c'_j\}$  is not resolved, by Lemma 4.

### 5 Parameterized hardness of Metric Dimension/tw

In this section, we produce in polynomial time an instance  $(G'', k'')$  of METRIC DIMENSION equivalent to  $(G', \mathcal{X}, km, \mathcal{P})$  of  $k$ -MULTICOLORED RESOLVING SET. The graph  $G''$  has also pathwidth  $O(k)$ . Now, an instance is just a graph and an integer. There is no longer  $\mathcal{X}$  and  $\mathcal{P}$  to constrain and respectively loosen the “resolving set” at our convenience. This creates two issues: (1) the vertices outside the former set  $\mathcal{X}$  can now be put in the resolving set, potentially yielding undesired solutions<sup>2</sup> and (2) our candidate solution (when there is a  $k$ -multicolored independent set in  $G$ ) may not distinguish all the vertices.

## 5.1 Construction

### 5.1.1 Forced set gadget

To deal with the issue (1), we introduce two new pairs of vertices for each  $V_i^j$ . The intention is that the only vertices resolving both these pairs simultaneously are precisely the vertices

<sup>2</sup> Also, it is now possible to put two or more vertices of the same  $V_i^j$  in the resolving set  $S$

of  $V_i^j$ . For any  $i \in [k]$  and  $j \in [m]$ , we add to  $G'$  two pairs of vertices  $\{p_i^j, q_i^j\}$  and  $\{r_i^j, s_i^j\}$ , and two gates  $\pi_i^j$  and  $\rho_i^j$ . Vertex  $\pi_i^j$  is adjacent to  $p_i^j$  and  $q_i^j$ , and vertex  $\rho_i^j$  is adjacent to  $r_i^j$  and  $s_i^j$ .

We link  $v_{i,1}^j$  to  $p_i^j$ , and  $v_{i,t}^j$  to  $r_i^j$ , each by a path of length  $t$ . It introduces two new neighbors of  $v_{i,1}^j$  and  $v_{i,t}^j$  (the brown vertices in Figure 4). We denote them by  $tb_i^j$  and  $bb_i^j$ , respectively. The blue and brown vertices are linked to  $\pi_i^j$  and  $\rho_i^j$  in the following way. We link  $tl_i^j$  and  $tr_i^j$  to  $\pi_i^j$  by a private path of length  $t$ , and to  $\rho_i^j$  by a private path of length  $2t - 1$ . We link  $bl_i^j$  and  $br_i^j$  to  $\pi_i^j$  by a private path of length  $2t - 1$ , and to  $\rho_i^j$  by a private path of length  $t$ . (Let us clarify that the names of the blue vertices  $bl_i^j$  and  $br_i^j$  are for “bottom-left” and “bottom-right”, and *not* for “blue” and “brown”.) We link  $tb_i^j$  (neighbor of  $v_{i,1}^j$ ) to  $\rho_i^j$  by a private path of length  $2t - 1$ . We link  $bb_i^j$  (neighbor of  $v_{i,t}^j$ ) to  $\pi_i^j$  by a private path of length  $2t - 1$ . Note that the general rule to set the path length is to match the distance between the neighbor in  $V_i^j$  and  $p_i^j$  (resp.  $r_i^j$ ). With that in mind we link, if it exists, the *top cyan vertex*  $tc_i^j$  (the one with smallest index  $\gamma$ ) neighboring  $V_i^j$  to  $\pi_i^j$  with a path of length  $\text{dist}(v_{i,\gamma}^j, p_i^j) = t + \gamma - 1$  where  $v_{i,\gamma}^j$  is the unique vertex in  $N(tc_i^j) \cap V_i^j$ . Observe that with the notations of the previous section  $tc_i^j = e_{i,\gamma}^j$ . We also link, if it exists, the *bottom cyan vertex*  $bc_i^j$  (the one with largest index  $\gamma$ ) to  $\rho_i^j$  with a path of length  $\text{dist}(v, r_i^j)$  where  $v$  is again the unique neighbor of  $bc_i^j$  in  $V_i^j$ .

It can be observed that we only have two paths (and not all six) from the at most three cyan vertices to the gates  $\pi_i^j$  and  $\rho_i^j$ . This is where the edges between the cyan vertices will become relevant. See Figure 4 for an illustration of the forced vertex gadget, keeping in mind that, for the sake of legibility, four paths to  $\{\pi_i^j, \rho_i^j\}$  are not represented.

### 5.1.2 Forced vertex gadget

We now deal with the issue (2). By *we add (or attach) a forced vertex* to an already present vertex  $v$ , we mean that we add two adjacent neighbors to  $v$ , and that these two vertices remain of degree 2 in the whole graph  $G''$ . Hence one of the two neighbors will have to be selected in the resolving set since they are true twins. We call *forced vertex* one of these two vertices (picking arbitrarily).

For every  $i \in [k]$  and  $j \in [m]$ , we add a forced vertex to the gates  $nw_i^j$  and  $se_i^j$  of  $P_i^{j,j+1}$ . We also add a forced vertex to each vertex in  $N(\{\pi_i^j, \rho_i^j\}) \setminus \{p_i^j, q_i^j, r_i^j, s_i^j\}$ . This represents a total of 12 vertices (6 neighbors of  $\pi_i^j$  and 6 neighbors of  $\rho_i^j$ ). For every  $j \in [m]$ , we attach a forced vertex to each vertex in  $N(g_j) \setminus \{c_j, c'_j\}$ . This constitutes 14 neighbors (hence 14 new forced vertices). Therefore we set  $k'' := km + 12km + 2km + 14m = 15km + 14m$ .

### 5.1.3 Finishing touches and useful notations

We use the convention that  $P(u, v)$  denotes the path from  $u$  to  $v$  which was specifically built from  $u$  to  $v$ . In other words, for  $P(u, v)$  to make sense, there should be a point in the construction where we say that we add a (private) path between  $u$  and  $v$ . For the sake of legibility,  $P(u, v)$  may denote either the set of vertices or the induced subgraph. We also denote by  $\nu(u, v)$  the neighbor of  $u$  in the path  $P(u, v)$ . Observe that  $P(u, v)$  is a symmetric notation but not  $\nu(u, v)$ .

We add a path of length  $\text{dist}(\nu(\pi_i^j, tr_i^j), sw_i^j) = t$  between  $\nu(\pi_i^j, tr_i^j)$  and  $se_i^j$ , and a path of length  $\text{dist}(\nu(\pi_i^j, bl_i^j), ne_i^{j-1}) = 2t - 1$  between  $\nu(\pi_i^j, bl_i^j)$  and  $nw_i^{j-1}$ . Similarly, we add a path of length  $\text{dist}(\nu(\rho_i^j, tr_i^j), sw_i^j) = 2t - 1$  between  $\nu(\rho_i^j, tr_i^j)$  and  $se_i^j$ , and a path of length  $\text{dist}(\nu(\rho_i^j, bl_i^j), ne_i^{j-1}) = t$  between  $\nu(\rho_i^j, bl_i^j)$  and  $nw_i^{j-1}$ . We added these four paths so that no forced vertex resolves any critical pair in the propagation gadgets  $P_i^{j-1,j}$  and  $P_i^{j,j+1}$ .

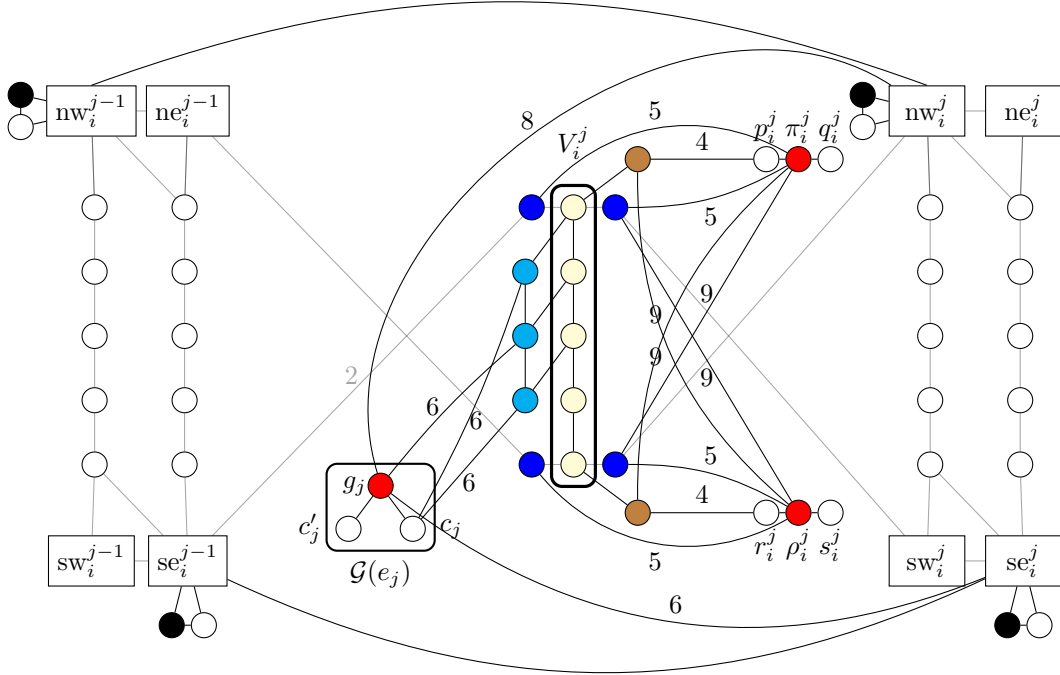

■ **Figure 4** Vertices  $tl_i^j, tr_i^j, bl_i^j, br_i^j$  (blue vertices) are linked to  $\pi_i^j, \rho_i^j$  by paths of appropriate lengths (see Section 5.1.1). Vertex  $tb_i^j$  is linked by a path to  $\rho_i^j$ , while  $bb_i^j$  is linked by a path to  $\pi_i^j$ . To avoid cluttering the figure, we did not represent four paths: from  $tl_i^j$  and  $bc_i^j$  to  $\rho_i^j$ , and from  $bl_i^j$  and  $tc_i^j$  to  $\pi_i^j$ . We also did not represent the paths already in the  $k$ -MRS-instance from the blue vertices to  $g_j$ . Black vertices are forced vertices. Gray edges are the edges in the propagation gadgets already depicted in Figure 3. Not represented on the figure, we add a forced vertex to each neighbor of the red vertices, except  $p_i^j, q_i^j, r_i^j, s_i^j, c_j, c'_j$ . Finally we add four more paths and potentially two edges (see Section 5.1.3).

Finally we add an edge between  $\nu(g_j, nw_i^j)$  and  $\nu(c_j, bc_i^j)$  whenever  $V_i^j$  have exactly three cyan vertices. We do that to resolve the pair  $\{\nu(c_j, tc_i^j), \nu(c_j, bc_i^j)\}$ , and more generally every pair  $\{x, y\} \in P(c_j, tc_i^j) \times P(c_j, bc_i^j)$  such that  $\text{dist}(c_j, x) = \text{dist}(c_j, y)$ . This finishes the construction of the instance  $(G'', k'' := 15km + 14m)$  of METRIC DIMENSION.

## 5.2 Correctness of the reduction

The two next lemmas will be crucial in Section 5.2.1. The first lemma shows how the forcing set gadget simulates the action of former set  $\mathcal{X}$ .

- **Lemma 6** ( $\star$ ). *For every  $i \in [k]$  and  $j \in [m]$ ,*
- $\forall v \in V_i^j, v$  resolves both pairs  $\{p_i^j, q_i^j\}$  and  $\{r_i^j, s_i^j\}$ ,
  - $\forall v \notin V_i^j, v$  resolves at most one pair of  $\{p_i^j, q_i^j\}$  and  $\{r_i^j, s_i^j\}$ ,
  - $\forall v \notin V_i^j \cup P(v_{i,1}^j, p_i^j) \cup P(v_{i,t}^j, r_i^j) \cup \{q_i^j, s_i^j\}, v$  does not resolve  $\{p_i^j, q_i^j\}$  nor  $\{r_i^j, s_i^j\}$ .

For Section 5.2.1, we also need the following lemma, which states that the forced vertices do not resolve critical pairs.

- **Lemma 7** ( $\star$ ). *No forced vertex resolves a pair of  $\mathcal{P}$ .*

### 5.2.1 MD-instance has a solution $\Rightarrow$ $k$ -MRS-instance has a solution

Let  $S$  be a resolving set for the METRIC DIMENSION-instance. We show that  $S' := S \cap \bigcup_{i \in [k], j \in [m]} V_i^j$  is a solution for  $k$ -MULTICOLORED RESOLVING SET. The set  $S \setminus S'$  is made of  $14km + 14m$  forced vertices, none of which is in some  $V_i^j \cup P(v_{i,1}^j, p_i^j) \cup \{q_i^j\} \cup P(v_{i,t}^j, r_i^j) \cup \{s_i^j\}$ . Thus by Lemma 6,  $S \setminus S'$  does not resolve any pair  $\{p_i^j, q_i^j\}$  or  $\{r_i^j, s_i^j\}$ . Now  $S'$  is a set of  $k'' - (14km + 14m) = km$  vertices resolving all the  $2km$  pairs  $\{p_i^j, q_i^j\}$  and  $\{r_i^j, s_i^j\}$ . Again by Lemma 6, this is only possible if  $|S' \cap V_i^j| = 1$ . Thus  $S'$  is a legal set of size  $k' = km$ . Let us now check that  $S'$  resolves every pair of  $\mathcal{P}$  in the graph  $G'$ .

By Lemma 7,  $S \setminus S'$  does not resolve any pair of  $\mathcal{P}$  in the graph  $G''$ . Thus  $S'$  resolves all the pairs of  $\mathcal{P}$  in  $G''$ . Since the distances between  $V_i^j$  and the critical pairs in the edge and propagation gadgets  $V_i^j$  is attached to are the same in  $G'$  and in  $G''$ ,  $S'$  also resolves every pair of  $\mathcal{P}$  in  $G'$ . Thus  $S'$  is a solution for the  $k$ -MRS-instance.

### 5.2.2 $k$ -MRS-instance has a solution $\Rightarrow$ MD-instance has a solution

Let  $S$  be a solution for  $k$ -MULTICOLORED RESOLVING SET. We show that  $S' := S \cup F$ , where  $F$  is the set of forced vertices, is a solution for METRIC DIMENSION.

► **Lemma 8** ( $\star$ ). *Every vertex in  $G''$  is distinguished by  $S'$ .*

The reduction is correct and it takes polynomial-time in  $|V(G)|$  to compute  $G''$ . The maximum degree of  $G''$  is 16. It is the degree of the vertices  $g_j$  ( $\text{nw}_i^j$  and  $\text{se}_i^j$  have degree at most 11,  $\pi_i^j$  and  $\rho_i^j$  have degree 8, and the other vertices have degree at most 5). We use the pathwidth characterization of Kirousis and Papadimitriou [19], to show:

► **Lemma 9** ( $\star$ ).  $\text{pw}(G'') \leq 90k + 83$ .

Then solving METRIC DIMENSION on constant-degree graphs in time  $f(\text{pw})n^{o(\text{pw})}$  could be used to solve  $k$ -MULTICOLORED INDEPENDENT SET in time  $f(k)n^{o(k)}$ , disproving the ETH.

---

#### References

- 1 Florian Barbero, Lucas Isenmann, and Jocelyn Thiebaut. On the Distance Identifying Set Meta-Problem and Applications to the Complexity of Identifying Problems on Graphs. In *13th International Symposium on Parameterized and Exact Computation, IPEC 2018, August 20-24, 2018, Helsinki, Finland*, pages 10:1–10:14, 2018. doi:10.4230/LIPIcs.IPEC.2018.10.
- 2 Zuzana Beerliova, Felix Eberhard, Thomas Erlebach, Alexander Hall, Michael Hoffmann, Matús Mihalák, and L. Shankar Ram. Network Discovery and Verification. *IEEE Journal on Selected Areas in Communications*, 24(12):2168–2181, 2006. doi:10.1109/JSAC.2006.884015.
- 3 Rémy Belmonte, Fedor V. Fomin, Petr A. Golovach, and M. S. Ramanujan. Metric Dimension of Bounded Tree-length Graphs. *SIAM J. Discrete Math.*, 31(2):1217–1243, 2017. doi:10.1137/16M1057383.
- 4 Gary Chartrand, Linda Eroh, Mark A. Johnson, and Ortrud Oellermann. Resolvability in graphs and the metric dimension of a graph. *Discrete Applied Mathematics*, 105(1-3):99–113, 2000. doi:10.1016/S0166-218X(00)00198-0.
- 5 Marek Cygan, Fedor V. Fomin, Lukasz Kowalik, Daniel Lokshtanov, Dániel Marx, Marcin Pilipczuk, Michal Pilipczuk, and Saket Saurabh. *Parameterized Algorithms*. Springer, 2015. doi:10.1007/978-3-319-21275-3.
- 6 Josep Díaz, Olli Pottonen, Maria J. Serna, and Erik Jan van Leeuwen. Complexity of metric dimension on planar graphs. *J. Comput. Syst. Sci.*, 83(1):132–158, 2017. doi:10.1016/j.jcss.2016.06.006.

- 7 Rodney G. Downey and Michael R. Fellows. *Fundamentals of Parameterized Complexity*. Texts in Computer Science. Springer, 2013. doi:10.1007/978-1-4471-5559-1.
- 8 David Eppstein. Metric Dimension Parameterized by Max Leaf Number. *J. Graph Algorithms Appl.*, 19(1):313–323, 2015. doi:10.7155/jgaa.00360.
- 9 Leah Epstein, Asaf Levin, and Gerhard J. Woeginger. The (Weighted) Metric Dimension of Graphs: Hard and Easy Cases. *Algorithmica*, 72(4):1130–1171, 2015. doi:10.1007/s00453-014-9896-2.
- 10 Henning Fernau, Pinar Heggeres, Pim van 't Hof, Daniel Meister, and Reza Saei. Computing the metric dimension for chain graphs. *Inf. Process. Lett.*, 115(9):671–676, 2015. doi:10.1016/j.ipl.2015.04.006.
- 11 Florent Foucaud, George B. Mertzios, Reza Naserasr, Aline Parreau, and Petru Valicov. Identification, Location-Domination and Metric Dimension on Interval and Permutation Graphs. II. Algorithms and Complexity. *Algorithmica*, 78(3):914–944, 2017. doi:10.1007/s00453-016-0184-1.
- 12 Michael R. Garey and David S. Johnson. *Computers and Intractability: A Guide to the Theory of NP-Completeness*. W. H. Freeman, 1979.
- 13 Frank Harary and Robert A Melter. On the metric dimension of a graph. *Ars Combin.*, 2(191-195):1, 1976.
- 14 Sepp Hartung and André Nichterlein. On the Parameterized and Approximation Hardness of Metric Dimension. In *Proceedings of the 28th Conference on Computational Complexity, CCC 2013, K.lo Alto, California, USA, 5-7 June, 2013*, pages 266–276, 2013. doi:10.1109/CCC.2013.36.
- 15 Stefan Hoffmann, Alina Elterman, and Egon Wanke. A linear time algorithm for metric dimension of cactus block graphs. *Theor. Comput. Sci.*, 630:43–62, 2016. doi:10.1016/j.tcs.2016.03.024.
- 16 Stefan Hoffmann and Egon Wanke. Metric Dimension for Gabriel Unit Disk Graphs Is NP-Complete. In *Algorithms for Sensor Systems, 8th International Symposium on Algorithms for Sensor Systems, Wireless Ad Hoc Networks and Autonomous Mobile Entities, ALGOSENSORS 2012, Ljubljana, Slovenia, September 13-14, 2012. Revised Selected Papers*, pages 90–92, 2012. doi:10.1007/978-3-642-36092-3\_10.
- 17 Russell Impagliazzo, Ramamohan Paturi, and Francis Zane. Which Problems Have Strongly Exponential Complexity? *Journal of Computer and System Sciences*, 63(4):512–530, December 2001.
- 18 Samir Khuller, Balaji Raghavachari, and Azriel Rosenfeld. Landmarks in Graphs. *Discrete Applied Mathematics*, 70(3):217–229, 1996. doi:10.1016/0166-218X(95)00106-2.
- 19 Lefteris M. Kirousis and Christos H. Papadimitriou. Interval graphs and searching. *Discrete Mathematics*, 55(2):181–184, 1985. doi:10.1016/0012-365X(85)90046-9.
- 20 Daniel Lokshtanov, Dániel Marx, and Saket Saurabh. Lower bounds based on the Exponential Time Hypothesis. *Bulletin of the EATCS*, 105:41–72, 2011. URL: <http://eatcs.org/beatcs/index.php/beatcs/article/view/92>.
- 21 Krzysztof Pietrzak. On the parameterized complexity of the fixed alphabet shortest common supersequence and longest common subsequence problems. *J. Comput. Syst. Sci.*, 67(4):757–771, 2003. doi:10.1016/S0022-0000(03)00078-3.
- 22 Peter J Slater. Leaves of trees. *Congr. Numer.*, 14(549-559):37, 1975.

■ **Table 1** Glossary of the construction.

Symbol/term	Definition/action
$\{a_{i,\gamma}^j, \alpha_{i,\gamma}^j\}$	critical pair of the propagation gadget $P_i^{j,j+1}$
$A_i^j$	set of vertices $\bigcup_{\gamma \in [t]} \{a_{i,\gamma}^j, \alpha_{i,\gamma}^j\}$
$bb_i^j$	bottom brown vertex, $\nu(v_{i,t}^j, r_i^j)$
$bc_i^j$	bottom cyan vertex (smallest index $\gamma$ )
$bl_i^j$	neighbor of $v_{i,t}^j$ in $P_i^{j-1,j}$
blue vertex	one of the four neighbors of $V_i^j$ in the propagation gadgets
$br_i^j$	neighbor of $v_{i,t}^j$ in $P_i^{j,j+1}$
brown vertex	vertices $\nu(v_{i,1}^j, p_i^j)$ and $\nu(v_{i,t}^j, r_i^j)$
$\{c_j, c'_j\}$	critical pair of the edge gadget $\mathcal{G}(e_j)$
cyan vertex	neighbor of $V_i^j$ in the paths to $\mathcal{G}(e_j)$
$E_i^j$	vertices in the paths from $V_i^j$ to $\mathcal{G}(e_j)$
$e_{i,\gamma}^j$	alternative labeling of the cyan vertices, neighbor of $v_{i,\gamma}^j$
$F$	set of all forced vertices
$\mathcal{G}(e_j)$	edge gadget on $\{g_j, c_j, c'_j\}$ between $V_i^j$ and $V_{i'}^j$ , where $e_j \in E(V_i, V_{i'})$
$mc_i^j$	middle cyan vertex (not top nor bottom)
$ne_i^j$	north-east gate of $P_i^{j,j+1}$
$nw_i^j$	north-west gate of $P_i^{j,j+1}$
$ne_i^j, sw_i^j$	resolve the critical pairs of $P_i^{j,j+1}$
$nw_i^j, se_i^j$	do not resolve the critical pairs of $P_i^{j,j+1}$
$\nu(u, v)$	neighbor of $u$ in the path $P(u, v)$
$\mathcal{P}$	list of critical pairs
$\{p_i^j, q_i^j\}$	pair only resolved by vertices in $V_i^j \cup P(v_{i,1}^j, p_i^j) \cup \{q_i^j\}$
$\pi_i^j$	gate of $\{p_i^j, q_i^j\}$ , linked by paths to most neighbors of $V_i^j$
$P_i^{j,j+1}$	propagation gadget between $V_i^j$ and $V_i^{j+1}$
$P(u, v)$	path added in the construction expressly between $u$ and $v$
$\{r_i^j, s_i^j\}$	pair only resolved by vertices in $V_i^j \cup P(v_{i,t}^j, r_i^j) \cup \{s_i^j\}$
$\rho_i^j$	gate of $\{r_i^j, s_i^j\}$ , linked by paths to most neighbors of $V_i^j$
$se_i^j$	south-east gate of $P_i^{j,j+1}$
$sw_i^j$	south-west gate of $P_i^{j,j+1}$
$t$	size of each $V_i$
$tb_i^j$	top brown vertex, $\nu(v_{i,1}^j, p_i^j)$
$tc_i^j$	top cyan vertex (largest index $\gamma$ )
$tl_i^j$	neighbor of $v_{i,1}^j$ in $P_i^{j-1,j}$
$tr_i^j$	neighbor of $v_{i,1}^j$ in $P_i^{j,j+1}$
$V_i$	partite set of $G$
$V_i^j$	“copy of $V_i$ ”, stringed by a path, in $G'$ and $G''$
$v_{i,\gamma}^j$	vertex of $V_i^j$ representing $v_{i,\gamma} \in V(G)$
$W_j$	endpoints in $V_i^j \cup V_{i'}^j$ of paths from $V_i^j \cup V_{i'}^j$ to $\mathcal{G}(e_j)$
$\mathcal{X}$	set containing all the sets $V_i^j$ for $i \in [k]$ and $j \in [m]$
$X_j$	neighbors of $W_j$ on the paths to $\mathcal{G}(e_j)$ (cyan vertices)