



HAL
open science

Optimism leads to optimality: Ambiguity in network formation

Péter Bayer, Ani Guerdjikova

► **To cite this version:**

Péter Bayer, Ani Guerdjikova. Optimism leads to optimality: Ambiguity in network formation. 2020.
hal-03005107v2

HAL Id: hal-03005107

<https://hal.science/hal-03005107v2>

Preprint submitted on 28 May 2021 (v2), last revised 30 Jan 2023 (v3)

HAL is a multi-disciplinary open access archive for the deposit and dissemination of scientific research documents, whether they are published or not. The documents may come from teaching and research institutions in France or abroad, or from public or private research centers.

L'archive ouverte pluridisciplinaire **HAL**, est destinée au dépôt et à la diffusion de documents scientifiques de niveau recherche, publiés ou non, émanant des établissements d'enseignement et de recherche français ou étrangers, des laboratoires publics ou privés.

Optimism leads to optimality: Ambiguity in network formation*

Péter Bayer[†] Ani Guerdjikova[‡]

May 28, 2021

Abstract

We analyze a model of endogenous two-sided network formation where players are affected by uncertainty in their opponents' decisions. We model this uncertainty using the notion of equilibrium under ambiguity (Eichberger and Kelsey, 2014). Unlike the set of Nash equilibria, the set of equilibria under ambiguity does not always include underconnected and thus inefficient networks such as the empty network. On the other hand, it may include networks with unreciprocated, one-way links, which comes with an efficiency loss as linking efforts are costly. We characterize equilibria under ambiguity and provide conditions under which increased player optimism comes with an increase in connectivity and realized benefits in equilibrium. Next, we analyze network realignment under a myopic updating process with optimistic shocks, and derive a global stability condition of efficient

*The authors would like to thank Cécile Aubert, Christophe Bravard, Gyögy Kozics, Stéphane Lemarié, Ronald Peeters, Anastas Tenev as well as seminar participants at the University of Grenoble, Toulouse School of Economics, and Maastricht University for helpful comments and suggestions. This research was supported by IUF, Labex MME-DII and the French National Research Agency in the framework of the “Investissements d’avenir” program ANR-15-IDEX-02.

[†]Toulouse School of Economics, 1 Esplanade de l’Université 31080 Toulouse, France. E-mail: peter.bayer@tse-fr.eu.

[‡]Laboratoire d’Économie Appliquée de Grenoble, Université Grenoble Alpes, 38400 Grenoble Cedex 9, France. E-mail: ani.guerdjikova@univ-grenoble-alpes.fr.

networks. Under this condition, called ‘aligned preferences’, a subset of the Pareto optimal equilibrium networks is reached, specifically, networks that maximize the players’ total benefits of connections.

1 Introduction

The question of how social networks form and which structures are both stable and efficient is of primary interest in economic literature. The use of classic equilibrium concepts such as the Nash equilibrium, however, invites a problem of multiplicity: the set of Nash equilibria encompasses both Pareto optimal, as well as Pareto dominated networks such as the empty network. Different equilibrium notions such as pairwise stability (Jackson and Wolinsky, 1996) and strong stability (Jackson and van den Nouweland, 2005) have been considered in the literature.¹ For models, in which links are strictly beneficial to all players and costs of link formation are sufficiently small (Goyal and Joshi (2003)’s “small costs” case, König et al. (2014)), the equilibrium network is unique and Pareto optimal. In general, however, (Brueckner (2006), Goyal and Joshi (2003)’s “large costs” case, the corresponding welfare analysis in Westbrook (2010), as well as Griffith (2019); Baumann (2019)) the problem of equilibrium selection and conflict between efficiency and stability in case of pairwise stability, and existence in case of strong stability persists. Concepts which do achieve efficiency such as the bilateral equilibrium (Goyal and Vega-Redondo, 2007), implicitly rely on the ability of pairs of players to coordinate with respect to their linking decisions, but are silent on how such coordination would take place.

We highlight these issues in models of endogenous network formation. A link between two players is treated as a value-generating opportunity (recording a duet,

¹Dutta and Mutuswami (1997) show how an allocation rule can be designed so as to implement a strongly stable efficient equilibrium. In general, such rules require transfers.

publishing a research paper, a productivity-increasing R&D partnership between two companies). Notably, as in Bloch and Dutta (2009) and Ding (2019), the value of each of the possible links depends on the identity of the partners to the link. However, it is exogenous in that it is not subject to network externalities (the quality of a recording or of a published paper does not depend on the set of other recordings or papers; the increase in productivity does not affect the productivity of firms outside of the partnership). We assume that linking is costly and requires costly efforts from both parties. The value of the link is realized if and only if both parties incur the cost. Notably, an investing player bears the cost even if her intended partner does not reciprocate (Bala and Goyal, 2000), thus generating strategic complementarities on the level of link formation. In the more interesting case where costs are convex in the number of maintained links, indirect negative network externalities arise; a player is negatively affected by any two of their opponents linking to each other as the link increases the opponents' costs of linking to the player, decreasing the player's prospects of obtaining beneficial links.

Resolving the multiplicity of equilibria and selecting for efficient outcomes has been a long-standing issue in the economic literature on networks. As first suggested by Harsanyi and Selten (1988), what is at hand is the players' reaction to uncertainty in their opponents' strategies – their inability to uniquely predict the behavior of their potential partners.² Ambiguity, as shown in Eichberger and Kelsey (2014), provides a powerful tool for modeling such uncertainty with the attitude towards ambiguity, the players' level of optimism, acting as an equilibrium selection device. Notably, optimism can select Pareto dominant equilibria

²The work by McBride (2006) on imperfect monitoring in networks captures the idea of uncertainty about the strategies played by others. However, similarly to the concept of rationalizability by Rubinstein and Wolinsky (1994) such unobservability leads to an expansion of the set of equilibrium networks, rather than acting as a selection device.

in coordination games (Eichberger and Kelsey, 2002; Eichberger et al., 2008) and leads to an increase in payoffs in the maximal equilibrium in supermodular games (Schipper, 2019).

While in the work on ambiguity in games, optimism is merely introduced as a formal tool capturing attitude towards such ambiguity, research in social psychology points out to the relevance of optimism in the process of social network formation. Data show that optimistic people are more likely to form and sustain links which are beneficial to them (Brissette et al., 2002; Andersson, 2012). The “tendency to expect favorable outcomes” (Srivastava and Angelo, 2009) results in optimists attaching more weight to their partners reciprocating their efforts towards establishing a relationship. Such expectations may become self-fulfilling as opponents reciprocate these linking offers even when they themselves are not optimistic. In general, optimism is identified as a pervasive individual feature (Peterson, 2000), which is positive both for individuals and the society as a whole (Freud, 1928; Tiger, 1979).

In economics, experimental studies have shown that ambiguity in opponents’ strategies is indeed present and leads to deviations of observed behavior from Nash equilibrium (Pulford and Colman, 2007; Di Mauro and Castro, 2008; Eichberger et al., 2008; Kelsey and Le Roux, 2015, 2017). Furthermore, attitudes towards such ambiguity are heterogeneous and show non-negligible rates of both optimism and pessimism (Camerer and Karjalainen, 1994; Ivanov, 2011; Eichberger et al., 2008; Li et al., 2019). Studies comparing entrepreneurs to non-entrepreneurs find that the former exhibit higher levels of optimism, Bengtsson et al. (2012), whereas Bogliacino and Gallo (2015) find that approximately 25% of entrepreneurs in their sample are ambiguity-loving and that ambiguity-loving positively correlates with turnover as a measure of performance. Persson and Seiler (2018) document that optimism is a distinguishing feature between incumbents and high-impact en-

entrepreneurial firms. Notably, Holm et al. (2013) identify willingness to accept ambiguity in social interactions and in particular, to bet on the “trustworthiness” of a partner, to be a key characteristic of entrepreneurs. In an experiment, Dollinger (1995) confirm that tolerance towards ambiguity is positively related to an entrepreneur’s willingness to engage in alliances. This suggests that ambiguity attitudes, and in particular, optimism, are also empirically relevant for the process of network formation among firms.

In this paper, we combine these ideas by introducing optimistic and pessimistic attitudes into a network formation game. Despite the complementarity of linking efforts, the convexity of linking cost implies that the game is not supermodular and thus, equilibrium existence cannot be established by Topkis (1979)’s theorem. Nevertheless, we establish equilibrium existence (Proposition 3.3) by showing that, starting from any network, a sequence of unilateral best-responses (under ambiguity) leads to an equilibrium in a finite number of steps. This result proves that such equilibria always exist, provides an algorithm for identifying equilibria under ambiguity in a network formation game, and shows that the equilibria are stable under simple learning dynamics.

We next discuss the effect of increased optimism in equilibrium networks under ambiguity. Optimism increases the weight players place on others reciprocating a link and thus increases the maximal number of links a player initiates as a best-response (Proposition 3.5). However, whether the number and quality of *realized* links increase with optimism is not so clear; e.g. it may happen that a player who becomes more optimistic severs an existing link in hopes of attaining a better one but is unsuccessful, leaving the new network less connected. We provide a sufficient condition under which optimism increases connectivity in equilibrium. We call a network monotonic if for each player, any link she formed is at least as valuable to her as any of the links that she has not formed, i.e. each player’s linking

decision is a monotonic function of her opponents' values. If an equilibrium under ambiguity is monotonic in this sense, then any increase of the players' optimism parameters results in a weakly more connected equilibrium (Proposition 3.7).

Finally, ambiguity allows us to study network realignment. While equilibrium analysis offers interesting insights, social networks are, by their nature, changeable. Relationships, partnerships, alliances continuously form, break apart, and re-form. Much of this variation is unaccounted for by the changes in the values of links or the individuals' cost structures, but occur due to variations in the individuals' subjective evaluation of the status quo equilibrium and their alternate prospects. In our model of ambiguity attitudes, this amounts to variations in the players' ambiguity perception and optimism. High-arousal emotional states (joy, fear, anger) are known to increase ambiguity perception, while low-arousal states (sadness, contentment) decrease it (Baillon et al., 2013). On the other hand, experiences of positive emotions is a key determinant of an individual's optimism (positive psychology) (Fredrickson, 2001).

Consequently, we consider the network's evolution under best-response dynamics with random changes to the individuals ambiguity and optimism parameters. Similarly to Kandori et al. (1993) (henceforth KMR), we assume that players have "realistic", utility-maximizing preferences (without ambiguity) and play the game accordingly, except in periods when they receive a random shock. Differently from KMR, the deviation in behavior related to the shock is not random, but optimal by their current ambiguity perception and attitude. They are temporary and may be followed by the player becoming again realistic in the next period. Shocks that induce high levels of optimism lead to players more actively pursuing high-value links, possibly by discarding already existing ones. In our model, highly pessimistic players discard existing links without forming new ones, thus, to capture more interesting cases of network realignment, we focus on shocks that amount to

surges of optimism.

We are particularly interested whether such network realignment can result in efficiency gains. As known from experimental studies, (Cooper et al., 1990; Van Huyk et al., 1990), coordination on a socially optimal equilibrium generally does not obtain in a one-shot game. Our dynamic model thus follows the approach of KMR and Young (1993). Such best-response dynamics have been studied both in network formation games (Watts, 2001) as well as in games with simultaneous choice of links and actions (Ely, 2002; Jackson and Watts, 2002a,b; Goyal and Vega-Redondo, 2005; Hojman and Szeidl, 2006; Galeotti and Goyal, 2010; Dawid and Hellman, 2014), see Hellman and Staudigl (2012) for a review. In general, neither uniqueness of the stochastically stable state, nor its efficiency are guaranteed, except in rather special cases, such as König et al. (2014) (in which, as mentioned above, the unique equilibrium is the complete graph) or Staudigl (2011) (who analyzes a potential game, in which all links have ex-ante identical value and there is no cost of link formation). Recent research has also identified the role of far-sightedness for convergence to optimal networks, Luo et al. (2018). Furthermore, the techniques developed by KMR present computational challenges when the set of equilibria is large as in most network formation games.

In this paper, we show that, no matter the starting network or the probability of optimistic surges, the proposed best-response dynamic produces a series of network realignments that lead to the formation of a Pareto optimal Nash equilibrium if a property we call the ‘alignment of preferences’ is met (Propositions 4.4 and 4.5). In particular, our dynamic selects the networks that maximize the players’ total benefits of connections. Aligned preferences means that all networks that maximize the players’ benefits of network connections in the set of Nash equilibrium networks (a social consideration) are monotonic (an individual consideration). Thus, social considerations ‘align’ with individual ones. This con-

dition is always satisfied if the values of all links are identical, therefore, surges of individual optimism leads to the formation of an optimal equilibrium network if efficiency is measured by the size of the network, a property that even previously considered pairwise notions fail to satisfy in this relatively simple case. If the condition is not met, a minimal counterexample of three players shows that these dynamics fail to produce the efficient network as the efficient network itself is unstable to surges of optimism.

The rest of the paper is organized as follows: Section 2 introduces the network formation game and defines the equilibrium under ambiguity concept. Section 3 analyzes the static network formation game under ambiguity; we show existence of equilibria, we provide a characterization, and study the comparative statics with respect to the players' attitude towards ambiguity. In Section 4, we turn towards a dynamic analysis of network realignment. We analyze a best-response dynamic with optimistic shocks and analyze its long-term behavior. For aligned preferences, the dynamic almost surely reaches the set of efficient networks in finite time. Section 5 concludes.

2 The network formation game

2.1 Notation and definitions

Let $n > 1$ and let $I = \{1, \dots, n\}$ be the finite set of players. A network on these players is represented by a binary $n \times n$ matrix x . For a disjoint pair $i, j \in I$ if $x_{ij} = 1$, then we say that i has a directed link towards j , or i links to j . If $x_{ij} = x_{ji} = 1$, we say that i and j are reciprocally linked to each other. As a shorthand we write $\{i, j\} \in x$ to mean $x_{ij} = x_{ji} = 1$ and $\{i, j\} \notin x$ to mean $x_{ij} = x_{ji} = 0$. By convention, for every $i \in I$ we set the values x_{ii} to 0. Let the set of networks of n players be denoted by X .

The network $x \in X$ is undirected if for every disjoint $i, j \in I$ it holds that

$$x_{ij} = x_{ji}.$$

Definition 2.1 (Neighborhoods and degrees in directed networks). For $i \in I$ we let $N_i^+(x) = \{j \in I: x_{ij} = 1\}$, $N_i^-(x) = \{j \in I: x_{ji} = 1\}$ denote the set of players who player i links to and the set of players who link to player i in network x , respectively. The set $N_i(x) = N_i^+(x) \cap N_i^-(x)$ is called the *neighborhood* of player i .

For $i \in I$ let $\deg_i^+(x) = |N_i^+(x)|$, $\deg_i^-(x) = |N_i^-(x)|$, and $\deg_i(x) = |N_i(x)|$ denote player i 's *out-degree*, *in-degree*, and *degree*, respectively.

It is clear that for undirected networks, the three neighbor sets and degrees coincide.

Definition 2.2 (Maximal undirected network contained in a network). Let the map $y: X \rightarrow X$ be defined as follows: for every disjoint $i, j \in I$, $y(x)_{ij} = y(x)_{ji} = x_{ij}x_{ji}$. The network $y(x)$ is the *maximal undirected network* contained in x .

For $X' \subseteq X$ we let $y(X')$ denote the image of X' . We introduce $y(X) = Y$ to denote the set of undirected networks. For $Y' \subseteq Y$ we let $y^{-1}(Y')$ denote the pre-image of Y' , i.e. the set of directed networks, whose maximal undirected network is a member of Y' .

For an undirected network $y \in Y$ let $|y| = \sum_{i \in I} \deg_i(y)/2$ denote the number of links in y .

Definition 2.3. For two networks x, x' we say that x' is *more connected* than x , denoted by $x \leq x'$ if for every $i, j \in I$ we have $x_{ij} \leq x'_{ij}$.

As typical, we write $x < x'$ to denote the asymmetric part of the relation $x \leq x'$.

For undirected networks $x, x' \in Y$, the union and set subtraction operators \cup and \setminus are interpreted the same way as for sets. Specifically, the network $(x \setminus x') \cup (x' \setminus x)$, containing all links that appear in exactly one of x and x' is called the symmetric difference between x and x' .

Definition 2.4 (Distance between undirected networks). For two undirected networks $x, x' \in Y$ the value $\phi(x, x') = |(x \setminus x') \cup (x' \setminus x)|$ is called the *distance* between x and x' .

2.2 Game definition

We now define a game of network formation with additive benefits gained from direct interactions. Let W be an $n \times n$ non-negative, symmetric, real matrix with the convention $w_{ii} = 0$ for $i \in I$, called the matrix of benefits. Let $c_i: \mathbb{N} \rightarrow \mathbb{R}_+$ be a strictly monotonically increasing, weakly convex function, such that $c_i(0) = 0$, called player i 's cost function. A strategy of player i is a binary n -vector $x_i = (x_{ij})_{j \in I}$ with $x_{ij} = 1$ representing the choice by i to link to j , and $x_{ij} = 0$ representing the choice not to link. By convention we take $x_{ii} = 0$ for all $i \in I$. The aggregate of the players' decisions $(x_i)_{i \in I}$ forms the directed network x . Let X_i denote player i 's set of strategies.

The payoff of player $i \in I$ is given as follows.

$$u_i(x) = \sum_{j \neq i} w_{ij} x_{ij} x_{ji} - c_i(\deg_i^+(x)). \quad (1)$$

The interpretation is the following: The players may form costly links with other players to receive the benefit associated with that link as given by the weight matrix. Benefits of links are only realized by the participants if both decide to link to one another. If only one decides to link to the other, a one-sided link is formed without any benefits to either player, if both decide not to link, no link is formed and no benefits are realized. Crucially, players incur costs of all outgoing links even ones that are not reciprocated.

Our game therefore bears close resemblance to Myerson (1991)'s independent link-formation process in which players independently make a list of their opponents with whom they wish to link and a mutual link ends up forming if and

only if both participants name each other. In our game players realize benefits from direct neighbors in the resultant network but pay costs for the number of opponents added to their list.

We show an application of this game in a model of monopolistic competition between firms with partnerships.

Example 2.5 (Monopolistic competition with partnerships, adapted from Acemoglu et al. (2006) and König and Rogers (2018)). Consider a set of n firms, each producing an intermediate good used to produce a final good (a numeraire) according to a production function

$$y(q_1, \dots, q_n) = \frac{1}{\gamma} \sum_{i=1}^n A_i^{1-\gamma} q_i^\gamma,$$

where $\gamma \in (0, 1)$, q_i is the amount of the intermediate good i , whereas A_i is the productivity of firm i . The production function of firm i transforms a unit of the numeraire good into a unit of the intermediate good. The inverse demand of the final producer for intermediate good i is easily computed to be:

$$\rho_i(q_i) = \left(\frac{A_i}{q_i} \right)^{1-\gamma}$$

implying that the optimal supply of firm i is given by

$$q_i^* = \gamma^{\frac{1}{1-\gamma}} A_i$$

and its maximal profit is:

$$\pi_i^* = (1 - \gamma) \gamma^{\frac{\gamma}{1-\gamma}} A_i.$$

Denoting by $\phi = (1 - \gamma) \gamma^{\frac{\gamma}{1-\gamma}}$, $\pi_i^* = \phi A_i$.

Suppose that intermediate good producers can engage in partnerships which can generate increases in productivity. These are specific to the firms engaging in the partnership so that the success of a given partnership has no effect on the added value obtained from other partnerships. The increase in productivity is given by

$\frac{w_{ij}}{\phi} = \frac{w_{ji}}{\phi} \geq 0$ for each of the partner-firms and is realized if and only if both firms simultaneously put in a costly effort such as sharing know-how, engaging in further research and development, or coordinating managerial activities.³ If only one of the firms contributes to the partnership, it bears the cost of the effort, even though no increase in productivity is generated. $x_{ij} \in \{0, 1\}$ denotes the unilateral decision of firm i to partner with j and thus to incur the cost of such a partnership. The cost of effort is firm-specific and depends on the number of partnerships the firm is actively engaged in, $c_i\left(\sum_{j \neq i} x_{ij}\right)$ with marginal cost increasing in the number of existing partnerships. Thus, the final profit of a given firm can be written as:

$$\pi_i(x_i, x_{-i}) = \phi \left(A_i + \sum_{j \neq i} \frac{w_{ij}}{\phi} x_{ij} x_{ji} \right) - c_i \left(\sum_{j \neq i} x_{ij} \right) = \pi_i^* + \sum_{j \neq i} w_{ij} x_{ij} x_{ji} - c_i \left(\sum_{j \neq i} x_{ij} \right)$$

implying that each firm will select its partnerships to maximize (1).

We continue with a useful notation for marginal benefits and marginal costs.

Definition 2.6 (Marginal benefits, marginal costs). Let a network $x \in X$ be given. Then, player i 's *benefit on her marginal link* is $w'_i(x) = \min_{j \in N_i^+(x)} \{w_{ij}\}$. For $r \in \mathbb{N}$, player i 's *marginal cost function* is given by $c'_i(r) = c_i(r) - c_i(r-1)$ if r is positive and $c'(0) = 0$.

By convention we have $\min \emptyset = \infty$. Note that, while player i 's benefit on her marginal link equals the lowest value of her reciprocated link (i.e. her marginal benefit) if x is undirected, in directed networks we look at outgoing links. In the special case of linear cost functions, we denote constant marginal cost of player i by c_i .

We assume for simplicity that marginal costs are never equal to marginal benefits, that is, for every natural integer r and disjoint pair of players $i, j \in I$ we have

³Such a linear relation between productivity and the number of partnerships is first introduced in Klette and Kortum (2004).

$w_{ij} \neq c'_i(r)$. We make this assumption to simplify characterizations by avoiding indifference, but it may also be interpreted as the players always preferring not to link in case they are indifferent. Within the set of all possible matrices w and cost functions c , this property is generic.

We now introduce the equilibrium concepts of the game without ambiguity to serve as benchmarks. For a player $i \in I$, let $X_{-i} = \prod_{j \neq i} X_j$. The set of best response strategies of player i to the strategy combination chosen by her opponents is given by $B_i(x_{-i})$ defined by:

$$B_i(x_{-i}) = \arg \max_{x_i \in \{0,1\}^n} \left(\sum_{j \neq i} w_{ij} x_{ij} x_{ji} - c_i(\deg_i^+(x)) \right)$$

As usual in the literature, we write $B_i(x)$.

Definition 2.7. A network x is a Nash equilibrium of the game of network formation iff $x_i \in B_i(x)$ for all $i \in I$.

The following characterization follows in a straightforward way.

Lemma 2.8 (Nash equilibrium characterization). *A network x^* is a Nash equilibrium if and only if it is undirected and $w'_i(x^*) > c'_i(\deg_i(x^*))$ for all $i \in I$.*

Since linking to a player without reciprocation is costly without giving any immediate benefits, every Nash equilibrium is undirected, furthermore, each player's least profitable neighbor must bring more benefit than the marginal cost of the player's links. We denote the set of Nash equilibrium networks by X^* .

In general, network formation games have a multiplicity of Nash equilibria. Jackson and Wolinsky (1996) thus proposes a notion called pairwise stability, which, in this model, translates to a stronger property. We therefore define pairwise stable equilibria as a refinement of Nash equilibria.⁴

⁴Note that, in more general network formation games with externalities, pairwise stability is not a refinement of the set of Nash equilibria, as, pairwise stable networks are only stable

Definition 2.9 (Pairwise stable equilibria). A Nash equilibrium network x is *pairwise stable* if for any two distinct players $i, j \in I$ $x_{ij} = 0$ implies $u_i(x \cup \{i, j\}) < u_i(x)$ or $u_j(x \cup \{i, j\}) < u_j(x)$.

Pairwise stable networks have two properties: no player should be better off by the deletion of an existing link, and no two unlinked players should be better off by forming a reciprocated link between them. The first requirement is embedded in the definition of the Nash equilibrium, as severing a link is a unilateral decision. Their characterization follows in a straightforward way.

Lemma 2.10 (Pairwise stable equilibrium characterization). *The network x^* is a pairwise stable equilibrium if and only if x^* is a Nash equilibrium and for every $i, j \in I$ for which $x_{ij}^* = x_{ji}^* = 0$ we have $w_{ij} < \max\{c'_i(\deg_i(x^*) + 1), c'_j(\deg_j(x^*) + 1)\}$.*

Since, in a pairwise stable equilibrium, every mutually profitable link is already formed, any link that did not end up forming must be unprofitable for at least one participant.

In this paper we are interested in the conditions that allow the players' optimism to increase efficiency in network formation games. We raise two notions of efficiency, Pareto optimality and benefit-maximization in the set of Nash equilibria.

Definition 2.11 (Pareto optimal equilibrium network). A Nash equilibrium network $x \in X^*$ is *Pareto optimal* if there does not exist another Nash equilibrium network $x' \in X^*$ such that $u_i(x') \geq u_i(x)$ for all $i \in I$ with at least one strict inequality.

against individuals severing a *single* link, while Nash equilibria are stable against the severance of any number of links. Bloch and Jackson (2006) propose a concept called pairwise Nash stable networks which are stable against the severance of any number of links and the formation of a single link by any pair.

Clearly, a Pareto optimal Nash equilibrium network has to be pairwise stable, but not every pairwise stable equilibrium is Pareto optimal.

Our second efficiency notion measures the players' total benefits. For a network x , let $v(x) = \sum_{i \neq j} w_{ij} x_{ij} x_{ji}$ denote the total sum of realized benefits. It is clear that $v(x) = v(y(x))$.

Definition 2.12 (Maximum-benefit equilibrium networks). The network $x^* \in X^*$ is called a maximum-benefit equilibrium (MBE) network if $x \in \operatorname{argmax}_{x \in X^*} v(x)$.

Let the set of MBE networks be denoted by V^* . Such networks maximize total benefits from connections in the society, while ensuring that for each player i , the value she derives from her marginal link exceeds her cost, and i chooses her connections optimally given the behavior of the other players. Thus, they satisfy a participation constraint and an incentive constraint for each individual and can be, in principle, decentralized.

The basis of MBE networks is utilitarian efficiency but without explicitly considering the players' costs – although they do play some role as they are selected from the set of Nash equilibrium networks. Two conceptual reasons may exist to consider MBE in favor of or in addition to utilitarian efficient networks: (1) costs are player-specific constraints of maintaining social links, as such, in certain situations, benefits can be more easily transferable and measurable, while costs are hidden, (2) planners may be interested in the formation of the largest network (e.g. most duets recorded, most papers produced, most production cost-reducing partnerships formed) satisfying the players' participation constraints, rather than the utilitarian efficient one.

If all players' cost functions are linear, i.e. $c_i(\deg_i^+) = c_i \deg_i^+$ for constant values c_i , the notions of pairwise stability, Pareto optimality, and MBE networks coincide in a unique network defined by $\{i, j\} \in x \Leftrightarrow w_{ij} > \max\{c_i, c_j\}$.

2.3 Ambiguity attitudes and equilibrium under ambiguity

The concept of Nash equilibrium presupposes that players have correct beliefs about their opponents' behavior and best-respond to these beliefs. In games with multiple Nash equilibria, such an assumption seems rather strong. While players might indeed entertain beliefs about the behavior of the other players in the game, they might have limited confidence in such beliefs. The theory of ambiguity allows us to model such uncertainty about opponents' strategies by the use of non-additive probabilities called capacities.

Let \mathcal{X}_{-i} denote the set of all subsets of X_{-i} .

Definition 2.13 (Schmeidler (1989)). A *capacity* on $(X_{-i}, \mathcal{X}_{-i})$ is a function $\nu_i: \mathcal{X}_{-i} \rightarrow [0, 1]$ with $\nu_i(\emptyset) = 0$, $\nu_i(X_{-i}) = 1$ and $\nu_i(A) \leq \nu_i(A')$, whenever $A \subseteq A'$.

In words, a capacity is a non-additive measure, which is normalized between 0 and 1 and satisfies monotonicity with respect to set inclusion. In particular, a capacity will in general violate additivity: the measures assigned to an event $A \subseteq X_{-i}$, $\nu_i(A)$, and its complement $X_{-i} \setminus A$, $\nu_i(X_{-i} \setminus A)$ need not sum up to 1.

The notion of a capacity is very general. In this paper, we will use a special class of capacities, called NEO-additive capacities which allow for a distinction between the strength of a players' perception of ambiguity and their response to it, optimism or pessimism. These characteristics of the players are captured by two parameters, $\alpha_i \in [0, 1]$, and $\delta_i \in [0, 1]$.

Definition 2.14 (Chateauneuf et al. (2007)). For a player i , given her ambiguity parameters α_i, δ_i , and a probability measure π_i on $(X_{-i}, \mathcal{X}_{-i})$, the *NEO-additive capacity* $\nu_i(\cdot | \alpha_i, \delta_i, \pi_i)$ on $(X_{-i}, \mathcal{X}_{-i})$ is defined as follows:

$$\nu_i(A | \alpha_i, \delta_i, \pi_i) = \begin{cases} 0 & \text{if } A = \emptyset, \\ 1 & \text{if } A = X_{-i}, \\ \delta_i \alpha_i + (1 - \delta_i) \pi_i(A) & \text{otherwise.} \end{cases}$$

A NEO-additive capacity can be interpreted as follows: the probability distribution π_i player i 's belief about the behavior of her opponents. The degree of confidence of i in this belief is given by $(1 - \delta_i)$. In particular, if $\delta_i = 0$, the degree of confidence is 1, i is not affected by ambiguity, and her subjective beliefs are represented by π_i itself. When the degree of confidence $(1 - \delta_i) < 1$, the player perceives ambiguity δ_i with respect to her best estimate π_i . Intuitively, δ_i identifies a set of probability distributions given by the convex combination of π_i with the set of all possible probability measures on X_{-i} , $\Delta(X_{-i})$,

$$\Pi_i = (1 - \delta_i) \{\pi_i\} + \delta_i \Delta(X_{-i})$$

that the player takes into account when deciding on her strategy.

The effect of such ambiguity on i 's beliefs about an event A depends on the player's degree of optimism, α_i . When $\alpha_i = 0$, the player is a complete pessimist and her beliefs scale down the probability of any event A (except for the whole event X_{-i}) by her degree of confidence, $(1 - \delta_i)$. For a fully optimistic player with $\alpha_i = 1$, the probabilities of all events (except the impossible one, \emptyset) are overweighted. More generally, for intermediate degrees of optimism, i will overweight events with low probability and underweight those with high probabilities.

In this paper, we will restrict attention to pure strategies and thus, to capacities for which π_i is a Dirac measure on some strategy combination of the opponents, $x_{-i} \in X_{-i}$, $\pi_i(x_{-i}) = 1$. Slightly abusing notation, we will write $\nu_i(\cdot | \alpha_i, \delta_i, x_{-i})$ to denote such a capacity.

Given i 's subjective beliefs expressed by NEO-additive capacity $\nu_i(\cdot | \alpha_i, \delta_i, x_{-i})$, her Choquet expected payoff from choosing a strategy x_i is given by the Choquet integral of the payoff function u_i with respect to ν_i .

Definition 2.15 (Chateauneuf et al. (2007)). The Choquet expected payoff with respect to a NEO-additive capacity ν_i with parameters α_i , δ_i and π_i such that

$\pi_i(x_{-i}) = 1$ for some $x_{-i} \in X_{-i}$ is given by:

$$\begin{aligned} U_i(x_i, \nu_i(\cdot|\alpha_i, \delta_i, x_{-i})) &= \int u_i(x_i, \tilde{x}_{-i}) d\nu_i \\ &= \delta_i \left[\alpha_i \max_{\tilde{x}_{-i} \in X_{-i}} u_i(x_i, \tilde{x}_{-i}) + (1 - \alpha_i) \min_{\tilde{x}_{-i} \in X_{-i}} u_i(x_i, \tilde{x}_{-i}) \right] + (1 - \delta_i) u_i(x_i, x_{-i}) \\ &= \alpha_i \max_{\pi \in (1-\delta_i)\{\pi_i\} + \delta_i \Delta(X_{-i})} E_\pi [u_i(x_i, \tilde{x}_{-i})] + (1 - \alpha_i) \min_{\pi \in (1-\delta_i)\{\pi_i\} + \delta_i \Delta(X_{-i})} E_\pi [u_i(x_i, \tilde{x}_{-i})] \end{aligned}$$

In words, player i 's Choquet expected payoff of strategy x_i given her subjective belief ν_i is the sum of the expected payoff she would obtain under her objective belief π_i with weight $1 - \delta_i$, the highest possible payoff attainable by x_i with weight $\delta_i \alpha_i$, and the lowest payoff attainable by x_i , with weight $\delta_i(1 - \alpha_i)$. There are three extreme cases: for a realistic player i ($\delta_i = 0$), the Choquet expected payoff of x_i given ν_i coincides with the payoff of x_i given x_{-i} , for an optimistic/pessimistic player i ($\delta_i = \alpha_i = 1$ and $\delta_i = 1, \alpha_i = 0$ respectively), the Choquet expected payoff of x_i ignores the objective belief π_i and equals the largest/smallest payoff available through x_i .

Alternatively, the Choquet expected payoff can be interpreted as an α_i -max-min expected utility over the set of probability distributions centered around π_i with a “radius” of δ_i .

Notice that in our network formation game $\max_{x_{-i} \in X_{-i}} u_i(x_i, x_{-i})$ is always obtained at $x_{ji} = 1$ for every $j \neq i$, whereas $\min_{x_{-i} \in X_{-i}} u_i(x_i, x_{-i})$ obtains at $x_{ji} = 0$ for every $j \neq i$ and thus,

$$U_i(x_i, \nu_i(\cdot|\alpha_i, \delta_i, x_{-i})) = \sum_{j \neq i} x_{ij} w_{ij} (\delta_i \alpha_i + (1 - \delta_i) x_{ji}) - c_i(\deg_i^+(x)), \quad (2)$$

The best response correspondence of player i given that her beliefs are represented by a NEO-additive capacity ν_i is defined as usual by

$$B_i(\nu_i(\cdot|\alpha_i, \delta_i, x_{-i})) = \arg \max_{x_i \in X_i} U_i(x_i, \nu_i(\cdot|\alpha_i, \delta_i, x_{-i})).$$

As most definitions of equilibrium, the equilibrium under ambiguity imposes consistency between equilibrium beliefs and equilibrium behavior. Differently from the standard Nash equilibrium concept, in our framework, players perceive ambiguity about the behavior of their opponents. Hence, their beliefs will in general assign positive weight to strategies, which are not used in equilibrium. The consistency notion is thus imposed on a subset of strategies assigned positive weights, on those that are in the support of the the objective beliefs, π_i . In the case, in which π_i is a Dirac measure on some x_{-i} , the support of π_i is given by x_{-i} , the strategy combination played by the other players.

We now adapt the equilibrium under ambiguity concept of Eichberger and Kelsey (2014) to our framework as follows:

Definition 2.16 (Eichberger and Kelsey (2014)). A vector of NEO-additive capacities $(\nu_i^*)_{i \in I}$ form an *equilibrium under ambiguity* (EUA) if for every $i \in I$, $x_{-i}^* \in B_{-i}(\nu_{-i}^*)$.

EUA imposes constraints both on players' strategies and on players' beliefs. In particular, whenever player i 's best estimate is that strategy combination x_{-i} will be played by her opponents, this strategy combination is a vector of each of her opponent's best responses according to their respective equilibrium beliefs given by ν_{-i}^* . It is easily seen that this condition can be equivalently rewritten as:

$$x_i^* \in B_i(\nu_i(\cdot \mid \alpha_i, \delta_i, x_{-i}^*))$$

for all $i \in I$, which illustrates the similarity of the concept to the Nash equilibrium.

3 The effects of increased optimism

We begin by a characterization of a player's best response under parameters α_i and δ_i . To simplify the analysis and avoid the cases of indifference we will discuss

ambiguity parameters $\delta_i, \alpha_i, i \in I$ such that for every $i, j \in I$ and every $r \in \mathbb{N}$ we have $w_{ij}\delta_i\alpha_i \neq c'_i(r)$ and $w_{ij}(\delta_i\alpha_i + 1 - \delta_i) \neq c'_i(r)$, which is a generic setting of parameters.

The behavior of players maximizing (2) is showcased by the following characterization.

Lemma 3.1 (Best response under ambiguity). *For $x \in X$ and $i \in I$, and $x'_i \in X_i$ let $x' = (x'_i, x_{-i})$. Then, $x'_i \in B_i(\nu_i(\cdot | \alpha_i, \delta_i, x_{-i}))$ if and only if for every $j \neq i$ we have $x_{ij} = 1$ if and only if the following two properties hold:*

1. $w_{ij}(\delta_i\alpha_i + (1 - \delta_i)x_{ji}) > c'_i(\deg_i(x'))$ (the benefit of linking to j exceeds marginal cost),
2. for every k such that $x'_{ik} = 0$ we have $w_{ij}(\delta_i\alpha_i + (1 - \delta_i)x_{ji}) \geq w_{ik}(\delta_i\alpha_i + (1 - \delta_i)x_{ki})$ (none of the non-neighbors is a better pick than j).

To illustrate the effect of ambiguity, compare the above conditions to the case without it ($\delta_i = 0$ for all i). A player i with a belief of her opponents' behavior, x_{-i} , ranks her opponents by the value $w_{ij}x_{ji}$: their value times their willingness to link to i . Player i 's best response will be to link to a selection of her opponents with the highest such value, stopping to form more links once her marginal cost exceeds the best unlinked opponent's perceived value.

Players affected by ambiguity behave very similarly but they will not place full confidence on their beliefs x_{-i} . Instead, they will rank their opponents based on a distorted value $w_{ij}(\alpha_i + (1 - \delta_i))x_{ji}$. The higher their perception of ambiguity, the less weight they will place on their belief, and the more optimistic they are, the stronger they will distort towards the belief that any opponent will link to them. Highly optimistic players will focus only the available benefit of a link, w_{ij} , while highly pessimistic ones will make their decisions in response to a distorted belief that no opponent will link to them.

w_{ij}	$> \frac{c'_j(x^*)}{\delta_j \alpha_j}$	$\in \left(\frac{c'_j(x^*)}{\delta_j \alpha_j + 1 - \delta_j}, \frac{c'_j(x^*)}{\delta_j \alpha_j} \right)$	$< \frac{c'_j(x^*)}{\delta_j \alpha_j + 1 - \delta_j}$
$> \frac{c'_i(x^*)}{\delta_i \alpha_i}$	$x_{ij}^* = x_{ji}^* = 1$	$x_{ij}^* = x_{ji}^* = 1$	$x_{ij}^* = 1, x_{ji}^* = 0$
$\in \left(\frac{c'_i(x^*)}{\delta_i \alpha_i + 1 - \delta_i}, \frac{c'_i(x^*)}{\delta_i \alpha_i} \right)$	$x_{ij}^* = x_{ji}^* = 1$	$x_{ij}^* = x_{ji}^* = 0 \text{ or } 1$	$x_{ij}^* = x_{ji}^* = 0$
$< \frac{c'_i(x^*)}{\delta_i \alpha_i + 1 - \delta_i}$	$x_{ij}^* = 0, x_{ji}^* = 1$	$x_{ij}^* = x_{ji}^* = 0$	$x_{ij}^* = x_{ji}^* = 0$

Table 1: EUA characterization. High-value directions always form, low-value directions never form in equilibrium. In-between-value directions form only if reciprocated, either because the opposite direction is high-value, or because the opposite direction is also an in-between-value. If, for two players, both directions are ‘in-between’-value, there may exist some equilibria where a reciprocated link is formed and some where neither direction forms. Note: we use the convention $1/0 = \infty$.

The characterization of EUA networks follows immediately.

Corollary 3.2 (EUA characterization). *The network x^* is an EUA of a game given by W and c if and only if for every trio $i, j, k \in I$ such that $x_{ij}^* = 1, x_{ik}^* = 0$ we have*

$$w_{ij}(\delta_i \alpha_i + x_{ji}^*(1 - \alpha_i)) \geq w_{ik}(\delta_i \alpha_i + x_{ki}^*(1 - \alpha_i))$$

and every pair $i, j \in I$ x^* follows rules presented by Table 1.

As Table 1 shows, equilibrium relations each player has three types of opponents in equilibrium which results in a total of nine qualitative types of equilibrium pairwise relations. A player may identify links that she will initiate even if the opponent does not reciprocate. This can only happen if the player is sufficiently optimistic. If such a high-value opponent likewise considers the initiating player valuable enough, a reciprocated link forms between them. If the initiating player is low-value for the opponent, a one-way link forms.

A player may also identify low-value opponents to whom she will not link even if that opponent initiates a link towards her. This may either be due to the fact that the player is highly pessimistic, or has other higher value opponents she intends to prioritize. In this case the player may have incoming one-way links from low-value opponents who consider her high-value.

Every other opponent is ‘in-between’-value; the player will only form such a link if she believes it will be reciprocated. If an ‘in-between’-value opponent considers her as high-value, the opponent will initiate and the player will reciprocate. If she is considered low-value, no links will form. Two players who consider each other ‘in-between’-value may link to each other but no directed link can exist between them.

There are two important differences between Nash equilibrium networks and EUA: First, the empty network may not be an EUA as high-value directions will always form in equilibrium. As a result, existence becomes a non-trivial issue (note that whenever the cost function is strictly concave, the game is not supermodular in the players’ own strategies and thus, the standard existence result of Topkis (1979) cannot be used). Second, an EUA network may contain directed links. To obtain a direct comparison with the set of Nash equilibrium networks, one can take $\delta_i = 0$ for all i , in which case the threshold for high-value opponents becomes infinity, effectively eliminating the top row and left column of Table 1, and leading to the characterization in Lemma 2.8.

We now state a general existence result of EUA.

Proposition 3.3 (Existence of EUA). *An equilibrium under ambiguity exists for any network formation game and any set of ambiguity parameters that satisfy the assumptions of no indifference.*

Proposition 3.3 shows the existence of pure equilibria. We obtain this result by considering strict best-response dynamics: starting in an arbitrary network, we show that no strict best-response improvement path can revisit a network it had visited before, thus any such path must arrive in a network where no player has a way to improve. That network is an EUA. Furthermore, the set of EUA are thus the absorbing sets of best-response dynamics under ambiguity.

We now examine the effects of increasing player optimism, starting with its

effects on the number of out-neighbors. While we will not obtain a direct result, we are able to derive monotonicity conditions on player optimism and the minimal and maximum number of out-neighbors. We begin with a formal definition of these two concepts.

Definition 3.4 (Minimal and maximal out-degree). For player $i \in I$ her *minimal* and *maximal out-degree*, denoted by $\underline{d}_i(\alpha_i, \delta_i)$ and $\bar{d}_i(\alpha_i, \delta_i)$ are defined as

$$\begin{aligned}\underline{d}_i(\alpha_i, \delta_i) &= \deg_i^+(x) \text{ where } x_i \in B_i \left(\nu_i \left(\cdot | \alpha_i, \delta_i, (x_{ji} = 0)_{j \neq i} \right) \right), \\ \bar{d}_i(\alpha_i, \delta_i) &= \deg_i^+(x) \text{ where } x_i \in B_i \left(\nu_i \left(\cdot | \alpha_i, \delta_i, (x_{ji} = 1)_{j \neq i} \right) \right),\end{aligned}$$

respectively.

For fixed ambiguity parameters we simply write \underline{d}_i and \bar{d}_i . These are the number of links player i offers in a best response to the belief that no players link to i and all players link to i , respectively. Since indifferences of linking and not linking are ruled out, these values are well-defined, with \underline{d}_i being the largest degree r such that $r \geq |\{j \in I: \alpha_i \delta_i w_{ij} > c'_i(r)\}|$ holds and \bar{d}_i being the largest degree r such that $r \geq |\{j \in I: (\alpha_i \delta_i + (1 - \delta_i)) w_{ij} > c'_i(r)\}|$ holds.

It is clear that \underline{d}_i and \bar{d}_i are also lower and upper estimates, respectively, of the number of out-links that player i can have in any EUA network.

Note that for any $\alpha_i \in [0, 1]$ we have $\underline{d}_i(\alpha_i, 0) = 0$, i.e. without ambiguity, players do not link if no player links to them, also, for any $\delta_i \in [0, 1]$ we have $\underline{d}_i(0, \delta_i) = \bar{d}_i(0, \delta_i) = 0$, i.e. pessimistic players do not link to anyone.

For every $\alpha_i \in [0, 1]$ the value $\bar{d}_i(\alpha_i, 0)$ is unique, which we denote by d_i ; the maximum degree that player i can have in a best response when not affected by ambiguity.

We now show that an increase of a player's optimism without changing her perception of ambiguity raises both the lower- and upper bounds.

Proposition 3.5 (Minimal and maximal out-degree comparative statics). *For every $i \in I$, every $\alpha'_i > \alpha_i$, and every δ_i we have $\underline{d}_i(\alpha'_i, \delta_i) \geq \underline{d}_i(\alpha_i, \delta_i)$, and $\bar{d}_i(\alpha'_i, \delta_i) \geq \bar{d}_i(\alpha_i, \delta_i)$.*

By Proposition 3.5, a player's bounds on the number of out-links increase in any best response and in any equilibrium with the player's optimism as the perceived value of all potential links also increases.

However, the number of links in an equilibrium network, or even the equilibrium degree of the player becoming more optimistic, may decrease. This is because the player's new initiated links, if any, are not necessarily reciprocated, while she may cut her existing ones in her attempt to link to higher-value opponents. For this reason the comparative statics between player optimism and the size of the equilibrium network is not straightforward. We identify a sufficient condition, called the monotonicity of networks, that guarantees that optimism increases the connectivity of equilibrium networks.

Definition 3.6 (Monotonic network). Network x is *monotonic in linking decisions* (monotonic, for short) for player i if for every $j, k \in I$ such that $w_{ij} \geq w_{ik}$ we have $x_{ij} \geq x_{ik}$. Network x is monotonic if for every $i \in I$ it is monotonic for i .

If x is monotonic, then all players i link to some selection of their top $\text{deg}_i^+(x)$ choices of opponents. If an undirected network is monotonic, a player can only increase the value of her links by forming more links, not by replacing her existing links with better ones. We show that if an equilibrium is monotonic, then upon an increase in the players' optimism there will always exist an equilibrium under the new parameters which is weakly more connected.

Proposition 3.7 (Monotonic equilibrium comparative statics). *Let $x \in X^*(\delta, \alpha)$ be monotonic and consider an $\alpha' \geq \alpha$. Then, there exists an EUA network, $x' \in X^*(\alpha', \delta)$ such that $y(x) \leq y(x')$.*

By Proposition 3.7, we thus obtain that if an equilibrium is monotonic, an increase in the players' optimism will lead to more reciprocated links, increasing the value of realized benefits in the network as well.

Example 3.8 (Monotonic equilibrium with increased optimism). To demonstrate this result we consider a network of four players, A , B , C , and D . The links $\{A, B\}$ and $\{C, D\}$ give a high value H , while $\{A, D\}$ and $\{B, C\}$ offer a low value L with $H > L > 0$. Links $\{A, C\}$ and $\{B, D\}$ give a value of 0. Suppose that for all players we have $c'_i(2) < L$. Then, the unique Pareto optimal network is $x^* = \{\{A, B\}, \{B, C\}, \{C, D\}, \{A, D\}\}$, while any subset of x^* constitutes a Nash equilibrium network. Consider the monotonic equilibrium network $x = \{\{A, B\}, \{C, D\}\}$ and parameters δ_i and α_i such that $((\alpha_i \delta_i) + (1 - \delta_i))H > c'_i(1)$, $\delta_i L > c'_i(2)$, and $\alpha_i \delta_i L < c'_i(2)$. Then, x is the only EUA. Suppose that for all i α_i increases to α'_i in a way that $\alpha'_i \delta_i L > c'_i(2)$. Under the listed assumptions such values of α'_i are guaranteed to exist. Then, x^* becomes the only EUA of the modified game. Figure 1 shows this example graphically.

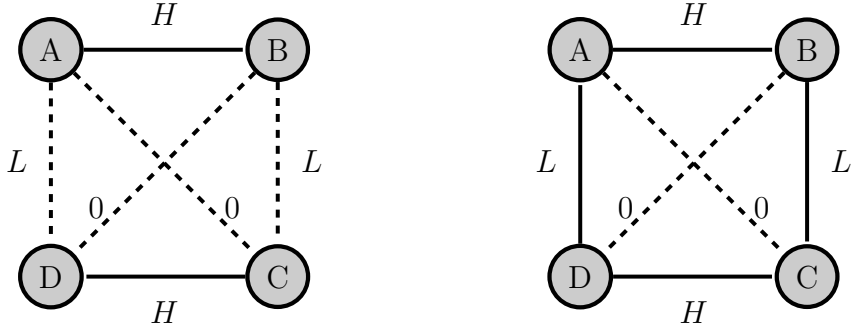

Figure 1: The weight network of Example 3.8. Reciprocated links are shown in continuous edges, no linking is indicated dashed ones. If $H > L > 0$, and if $c'_i(2) < L$ then network x^* (right panel) is the unique Pareto optimal network. There exist parameters α_i, δ_i , under which the underconnected but monotonic network x (left panel) is an EUA. Increasing the optimism parameters to $\alpha'_i > \alpha_i$ can lead to x^* being the only EUA.

In the special case when all cost functions are linear, the game is supermodular and increased optimism raises equilibrium connectivity regardless of whether the

initial equilibrium is monotonic (Schipper, 2019).

4 Network realignment through optimism

In this section we study the realignment of networks. By network realignment we refer to sequences of link formations and severances that lead from one equilibrium to another. This type of realignment may happen for several reasons. Equilibria that are stable for individual or pairwise changes may break apart due to a coordinated improvement by larger coalitions. Farsighted players may experiment in order to trigger a sequence of changes that increase their individual payoffs. Deviations may also occur randomly. However, there are reasons to believe that individuals change their linking behavior without either coalitional or farsighted considerations or their behavior being random. Partnerships, relationships, friendships may be broken, formed, or re-formed as a result of the participants' subjective evaluations of their current situation. As these evaluations change, so do the individuals' linking choices.

A motivation to study realignment is to select for equilibria that survive these changes, the conditions under which such equilibria even exist, and the efficiency properties of surviving equilibria. Since the seminal works of KMR and Young (1993), models of myopic adaptation with random mutations have been used as a selection device in games with multiple equilibria. In general, such models postulate a best-response type of adaptive dynamics. In each period, a player is chosen at random and revises her strategy by playing a best response to the current strategy combination of her opponents. With strictly positive probability, mutations (such as mistakes, experimentation) occur; instead of playing her best response, the player chooses a strategy at random.

In this paper, mutations, instead of leading to a random choice of a strategy, will affect the players' ambiguity parameters, their perception of ambiguity and

optimism. Specifically, we are interested in mutations that amount to optimistic surges. Players affected by optimistic surges seek out more and/or better neighbors, hence they produce interesting and plausible forms of network realignment. In our model, pessimistic surges would cause links to break down without new ones forming, which, while still plausible, is much less interesting as a driving force of realignment.

Our dynamic process takes place in discrete time, $t \in \mathbb{N}$. The network at time t will be denoted by x^t . Take an initial network structure x^{t-1} . In period t , a player i^t is chosen at random with uniform probability $1/n$ and receives an opportunity to revise her strategy to x_{it} . All other players continue playing the strategies corresponding to x_{-it}^{t-1} .

For player $i \in I$ set $\bar{\delta}_i \in (0, 1)$ and $\bar{\alpha}_i \in [0, 1]$ such that for every $j \in I \setminus \{i\}$ and $r \in \{0, n-1\}$ we have $c'_i(r) < \bar{\alpha}_i \bar{\delta}_i w_{ij}$ if and only if $c'_i(r) < w_{ij}$, and for $j, k \in I \setminus \{i\}$ with $w_{ij} > w_{ik}$ we have $\bar{\delta}_i \bar{\alpha}_i w_{ij} > w_{ik}$. Such values are guaranteed to exist with both $\bar{\delta}_i$ and $\bar{\alpha}_i$ being close to 1, as the player set is finite. These parameters represent highly optimistic behavior but not the complete ignorance of actual behavior (which would happen under $\delta_i = 1$). Thus, players' behavior will satisfy three properties: (1) if pressed to make a choice, a player will strictly prefer an unreciprocated link of a higher value to a reciprocated link of a lower value, (2) due to $\bar{\delta}_i < 1$ the player will strictly prefer a reciprocated link to an unreciprocated one of equal value, (3) the player always finds it optimal to have exactly d_i out-links to her top d_i choices, i.e. $\underline{d}_i(\bar{\alpha}_i, \bar{\delta}_i) = \bar{d}_i(\bar{\alpha}_i, \bar{\delta}_i) = d_i$.

The main parameter governing the dynamic process defined above is the frequency of optimistic shocks, denoted by $\beta \in (0, 1)$. If close to zero, our process resembles a best-response dynamic with regular, but infrequent optimistic shocks, and if close to 1, the players almost always react optimistically. We imagine small values of β to be the most plausible but our analysis is not sensitive to the ex-

act value as long as all players perform both optimistic and realistic actions with positive probability. The ambiguity parameters of player i^t at the time of revision are thus given by the following time-independent probability distribution:

$$\begin{aligned}\delta_{i^t}^t &= 0 \text{ and } \alpha_{i^t}^t \text{ arbitrary with probability } 1 - \beta, \\ \delta_{i^t}^t &= \bar{\delta}_{i^t} \text{ and } \alpha_{i^t}^t = \bar{\alpha}_{i^t}, \text{ with probability } \beta,\end{aligned}$$

Given her current ambiguity parameters, the revising player behaves myopically and chooses a best response to $x_{-i^t}^{t-1}$:

$$x_{i^t}^t \in B_{i^t}(\nu_{i^t}(\cdot | \alpha_{i^t}^t, \delta_{i^t}^t, x_{-i^t}^{t-1}))$$

If the best response $B_{i^t}(\cdot)$ is not a singleton, player i^t chooses a best response in $B_{i^t}(\cdot)$ uniformly at random. The resulting network at time t , x^t , is then given by

$$x^t(x^{t-1}, i^t, \alpha_{i^t}^t, \delta_{i^t}^t) = (x_{i^t}^t, x_{-i^t}^{t-1}).$$

In words, any updating player is an optimist with uniform probability β and a best-responder with probability $1 - \beta$.

In what follows, we will shorten the notation of an optimistic player's best response to x to $B_i^o(x) = B_i(\nu_i(\cdot | \bar{\alpha}_i, \bar{\delta}_i, x_{-i}))$.

This dynamic process describes a Markov chain on the set X . For $x, x' \in X$ let $p(x, x')$ denote the one-step transition probability from x to x' . It is clear that for every $x, x' \in X$ with $p(x, x') > 0$ there exists $i \in I$ such that either $x'_i \in B_i(x)$ or $x'_i \in B_i^o(x)$ and for every $j \neq i$ we have $x'_{-i} = x_{-i}$. For $m \in \mathbb{N}$ let $p^m(x, x')$ denote the transition probability from x to x' in exactly m steps. For a set of networks $X' \subseteq X$ let $p^m(x, X') = \sum_{x' \in X'} p^m(x, x')$ denote the probability of reaching this set from x in exactly m steps.

Definition 4.1 (Successor). For $x, x' \in X$ and $m \in \mathbb{N}$ we say that x' is an m -successor of x if $p^m(x, x') > 0$.

Denote the set of m -successors of network x by $S^m(x)$ and let $\bigcup_{m \in \mathbb{N}} S^m(x) = S(x)$ denote the set of all successors of x . By convention we include $x \in S(x)$.

We introduce the key condition of our convergence results.

Definition 4.2 (Aligned preferences). The players exhibit *aligned preferences* if every MBE network is monotonic.

Under aligned preferences, MBE networks are not only optimal for a benefit-maximizing society, but also satisfy an individual optimality condition for the players; each player is linked to a selection of her best opponents. This is an appealing property for a game to have, as without it we observe a conflict between efficiency in benefits and the players' incentives, but it is not a general one. It may be for instance, that none of the pairwise stable equilibria are monotonic. If preferences are not aligned, then conflicts may exist between different efficiency notions; maximum-benefit equilibrium networks can be Pareto dominated by other equilibrium networks, this is demonstrated by Example A.1 in the appendix. As we show in the next lemma, however, under aligned preferences, MBE networks are Pareto optimal.

Lemma 4.3. *Under aligned preferences, MBE networks are Pareto optimal in the set of Nash equilibria.*

Due to Lemma 4.3, when preferences are aligned, MBE is a stronger efficiency notion than Pareto optimality.

Proposition 4.4 (Stability of efficient networks under aligned preferences). *Suppose that the players exhibit aligned preferences. For every $x^* \in V^*$ and every $x' \in S(x^*)$ we have $x' \in y^{-1}(V^*)$.*

By Proposition 4.4, under aligned preferences, the set of MBE networks is stable under our dynamic of optimistic and best-responding players. More precisely,

starting the dynamical process in an efficient network, all successor networks will contain an MBE network as well as some additional one-way links. Formally, the set $y^{-1}(V^*)$ is absorbing under our dynamic process.

We now present our second main result. If preferences are aligned, then the dynamic described above always pushes the game towards networks that contain an MBE network, and, possibly, some additional one-way links. If there is a unique MBE network, then it by itself, is a stable equilibrium in terms of our dynamic, allowing for the creation and deletion of additional one-way links. If there is more than one MBE network, then they may communicate with each other under our dynamic but the total realized benefit of players never changes.

Proposition 4.5 (Efficient networks form almost surely under aligned preferences). *Suppose that the players exhibit aligned preferences. Then, for every $x \in X$ we have $\lim_{m \rightarrow \infty} p^m(x, y^{-1}(V^*)) = 1$*

Proposition 4.5 shows that, under aligned preferences, by the individual updates of players, an MBE network will form almost surely. Combined with 4.4, this means that, in terms of reciprocated links, the set of MBE networks is globally stable under these dynamics.

The key intuition behind the proof is that, from a sufficiently connected but inefficient equilibrium (from which, as we show, we can initiate the process) we can choose a link $\{i, j\}$ which is part of the efficient network but not part of the current network, and a player i who would initiate this link under an optimistic shock. If this is followed by j being given a best-responding revision opportunity she may reciprocate this link, possibly severing some others. There will then exist a series of best-responses through which we obtain a network which is strictly closer to the desired MBE network (notably by the inclusion of the link $\{i, j\}$ and the exclusion of some unnecessary links). Since the set of all networks is finite, repeating this process allows the dynamic to reach V^* in finite time. Once a network in V^* is

reached, the value of the network cannot decrease (Proposition 4.4).

We note the difference between our approach and that of KMR. Similarly to their approach, our best-response dynamic with optimistic shocks defines a Markov process on the set of strategy combinations and thus, on the set of directed networks. In KMR, the random mutations imply that any strategy can be chosen with strictly positive probability and thus, the Markov process visits any of the Nash equilibria infinitely often. In contrast, in our model, the asymmetric nature of the optimistic shocks implies that the Markov process reaches the set of MBE networks, with probability 1, regardless of initial conditions. Furthermore, the set $y^{-1}(V^*)$ is absorbing. Thus, rather than selecting for a single equilibrium, our dynamic selects for a *set* of equilibrium networks which are Pareto optimal.

The following example demonstrates network realignment through optimistic shocks under aligned preferences.

Example 4.6 (Network realignment). Consider the benefit weights given by Example 3.8, but with $c'_i(1) < L$ and $c'_i(2) > H$ for all i , that is, each player can have at most one neighbor in equilibrium. Then, the unique MBE network is $x^* = \{\{A, B\}, \{C, D\}\}$, but any undirected network where each player has at most one neighbor is also an equilibrium. Notably, $x = \{\{A, D\}, \{B, C\}\}$ is also pairwise stable, but not stable against optimistic surges.

The realignment process that leads from x to x^* is shown in Figure 2 and proceeds as follows. (1) under an optimistic shock, A severs her link to D and extends one to B . (2) a best-responding B severs her link to C and reciprocates A 's link. (3) C best responds, cutting her unreciprocated link to B . The network now has the link $\{A, B\}$ established, which is a Nash equilibrium network, and in network distance terms, closer to x^* . (4) under another optimistic shock, D extends a link to C . (5) a best-responding C reciprocates, forming the network x^* .

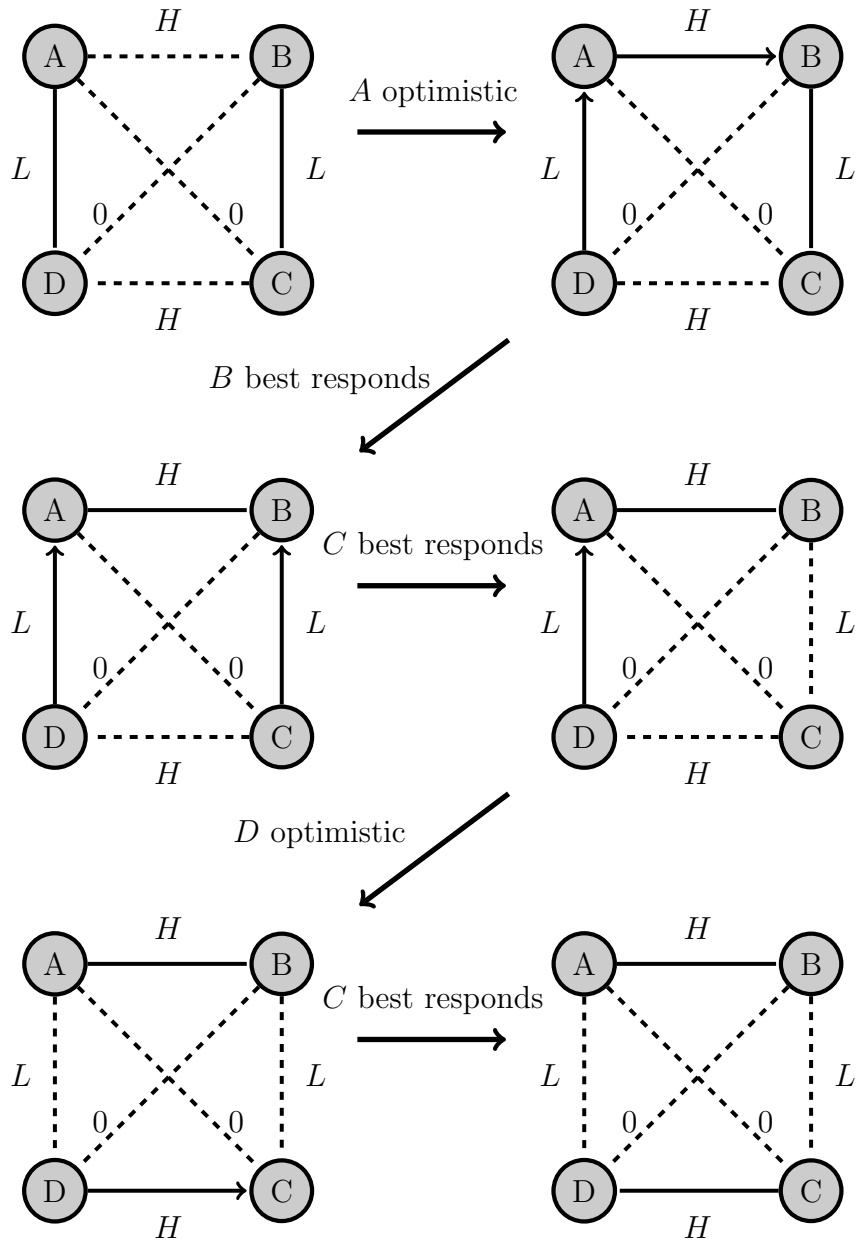

Figure 2: Network realignment from a Pareto dominated pairwise stable equilibrium to an MBE network. An optimistic shock compels A to seek out a new, better partner, severing her link to D and extending one to B . A best-responding B reciprocates A 's link and severs the one to C . A best-responding C deletes her unreciprocated link to B . Finally, when D receives an optimistic shock herself, she will extend a link to C which a best-responding C accepts.

If preferences are not aligned, then MBE networks are not always Pareto optimal, and they are also not stable for optimistic shocks; a player who is not linked to her best choice of neighbors, upon experiencing an optimistic shock, will invariably

delete her links to her existing neighbors and make offers to her best choices. This can be demonstrated by a minimal counterexample of three players.

Example 4.7. Consider a network of three players with $w_{12} = H$, $w_{13} = M$, and $w_{23} = L$ with $H > M > L > 0$. Suppose that $c'_1(1) < H$ and $c'_1(2) > M$, as well as $c'_3(1) < L$ and $c'_3(2) > M$ meaning that players 1 and 3 can entertain only one neighbor, while $c'_2(2) < L$, player 2 can entertain two neighbors. Then, the unique MBE is $x^* = \{\{1, 2\}, \{2, 3\}\}$, which is not monotonic, thus preferences are not aligned. Starting from x^* if player 3 receives an optimistic shock she will sever her link running to 2 and offers one to 1 which will be unreciprocated. These networks are shown in Figure 3.

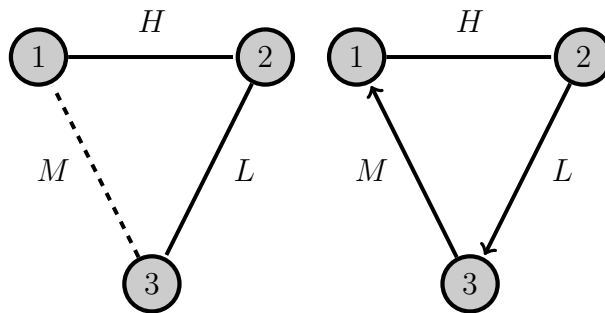

Figure 3: The network of Example 4.7. Player 2 can accommodate two neighbors, players 1 and 3 only one. The unique MBE (left) is pairwise stable, but unstable for an optimistic surge by player 3 who will sever her link with 2 and make an unreciprocated offer to 1 instead (right).

We conclude this section by showing convergence in the linear case, which is not covered by the case of aligned preferences.

Proposition 4.8. *Let the cost functions be linear. Then, for every $x \in X$ and the unique $x^* \in V^*$ we have $\lim_{m \rightarrow \infty} p^m(x, y^{-1}(x^*)) = 1$.*

Proposition 4.8 extends the convergence result laid out in Proposition 4.5 to all games with linear costs, without the precondition of aligned preferences. This is due to the fact that, under linear costs the unique MBE, which coincides with

the unique pairwise stable equilibrium, is stable for both optimistic and best-responding deviations.

5 Concluding remarks

In this paper we investigate a model of network formation with players facing ambiguity with respect to their opponents' linking decisions. We model this uncertainty using NEO-additive beliefs: players respond to mixtures of their rational beliefs as expressed by a probability measure of their opponents' actions, their optimistic beliefs, and their pessimistic ones.

To our knowledge, ours is the first project to consider ambiguity in strategies in a network formation game. We intuit that such a combination of frameworks is natural and fits well with behavioral considerations of network formation: optimistic players believe their linking offers are likely to be reciprocated, pessimistic players believe that opponents are unlikely to reciprocate. These considerations provide behavioral explanation to the existence of asymmetric interactions in social networks, namely, persistent one-way links. Similar explanations are absent in models focusing on joint improvements or individual rational behavior. Directed interactions may arise due to optimism as a player believes the opponent will reciprocate and thus make an offer to link without coordinating with the opponent. Even if the opponent does not reciprocate, if the optimism of the offering player persists, so does the one-way link. Under repeated surges of optimism followed by best-responding behavior, the linking offer is attempted and withdrawn repeatedly.

By explicitly modeling player optimism we also allow the link-formation process to be governed proactively by the players. Under Nash equilibrium, link formation was governed by the players passively best-responding to each other's actions or their beliefs about their opponents. In what has proven to be the mod-

ern benchmark tool, pairwise stability, link-formation is governed by the logic of random pairwise interactions where, upon meeting a mutually beneficial opponent, the pair decides to form a link. Here, players remain passive in creating these interactions and only act if the opportunity arises through events outside their control. Under our framework, optimistic players proactively seek out their best possible links, creating linking opportunities through a costly investment.

Our investigation of equilibrium under ambiguity reveals that optimism can, as expected, lead to better equilibrium outcomes by selecting against underconnected equilibria. Too much optimism, on the other hand, makes players blind to their available prospects in favor of the best they could possibly achieve and thus there is no general monotonic relationship between equilibrium connectivity and optimism. Monotonic equilibria, however, do improve in terms of connectivity if the players become more optimistic, as they feature no tradeoff between the players' available links and their best possible links. In these cases, optimism is helpful for the players to seek out additional profitable partners without severing their links to existing ones.

In addition to equilibrium, we study network realignment under ambiguity. Under aligned preferences, best-response dynamics with optimistic shocks lead to all links of a Pareto optimal network forming; specifically, one that maximizes benefits from links. This insight sheds some light to the role of optimism in a society: individual optimism begets an optimal social network without relying on formal or informal multilateral coordination devices. It is noteworthy that both optimism and realism are found to be necessary attitudes to produce this result, with optimism being the driving force to seek out newer and better links, while realism compels players to accept the status quo. If the frequency of optimistic shocks is high, efficient networks are reached faster but the system will spend more time in networks with directed links – even after all links of the Pareto optimal

equilibrium network have been formed. If this frequency is lower, Pareto optimal equilibria are reached later but players spend more time at their objective best response – i.e. in the actual equilibrium network. This suggests that there is an optimal amount, or rate, of optimism for a society which strikes a balance between the speed of convergence to the set of Pareto optimal networks, and mitigating the efficiency loss arising from the wasted effort of extending unreciprocated links. Finding this is an interesting direction for future research.

If preferences are not aligned, optimistic shocks are not enough to produce efficient networks – even the concept of an efficient network becomes more elusive as the efficiency notion that planners may be interested in, the maximum-benefit equilibria, and the one pertaining to the players’ well-being, Pareto optimality, are not in agreement. We thus cannot resolve the prevailing conflict between stability and efficiency in the general case. A possible way to relax the aligned preferences condition is by considering a higher degree of player sophistication. For instance, in Example 4.7, a player 2 who is informed of player 1’s payoff function may anticipate that player 1 will not sever her first-best link and is thus, unavailable. Alternatively, after several unsuccessful tries, she can also learn that player 1 will never reciprocate. Both would allow player 2 to be satisfied with her second-best outcome, which stabilizes the Pareto optimal network. This type of sophisticated selection of neighbors is beyond the scope of this paper.

Our model is without explicit network externalities. This choice simplifies our analysis as players evaluate their linking choices “link-wise”. Furthermore, this avoids the additional complexity of modeling the players’ beliefs of their neighbors’ (neighbors’, etc.) links, as well as their responses to these beliefs. As the players’ reliable information of links in the network that are distant from them can be scarce, a more general model of ambiguity in networks under explicit network externalities necessitates an epistemic foundation of players’ beliefs of distant links.

Finally, we mention pessimism, which, in our model, does not seem to have any positive role in building the network or realigning efficiently. Pessimistic shocks in our model amount to (possibly temporary) severances of links without forming new ones. Such a behavior may play a role in preventing the network from becoming too cluttered. This may be to the benefit of society if network interactions bring negative externalities, such as during a pandemic where being part of a connected social component exposes the individual to risk of infection. This is another interesting direction for future research.

A Appendix

A.1 Aligned preferences conditions

In this section we discuss implications and conditions of the preferences being aligned. Aligned preferences represent a restriction on the players' preferences in a way that individual considerations to link to one's favorite opponents, i.e. play monotonic strategies, are in agreement with social considerations that seek to maximize the players' sum of realized benefits.

If preferences are not aligned, MBE networks are not guaranteed to be Pareto optimal. This is illustrated by a counterexample.

Example A.1. Consider a network of six players shown in Figure 4.

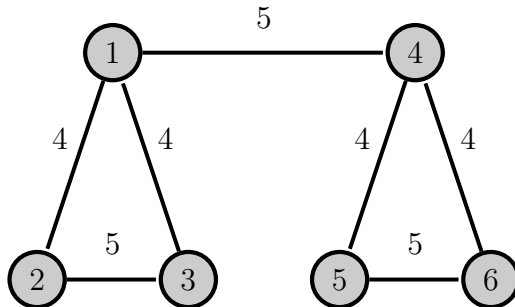

Figure 4: The weight network of example A.1. Links not shown in the figure are assumed to offer no benefits.

Suppose that the cost structure is such that $d_1 = d_4 = 2$, while $d_2 = d_3 = d_5 = d_6 = 1$. Then, the only MBE network is $x^* = \{\{1, 2\}, \{1, 3\}, \{4, 5\}, \{4, 6\}\}$ for a total weight of 16, but it is not monotonic for any player, hence preferences are not aligned.

Suppose that $c_1(1) = c_4(1) = 3.8$ and $c_1(2) = c_4(2) = 7.7$, which respects $d_1 = d_4 = 2$. Then, the network given by $x = \{\{1, 4\}, \{2, 3\}, \{5, 6\}\}$, with its weight of 15 Pareto dominates x^* .

Example A.1 also shows that the reverse of Lemma 4.3 is not true, that is, the existence of an equilibrium network which is monotonic and Pareto optimal does not imply that preferences are aligned. In the example the Pareto optimal equilibrium network is monotonic but preferences are not aligned as it is not an MBE network.

We highlight the special case where the benefits of all links are equal, i.e. players are only interested in the number of their neighbors. In this case preferences are always aligned and MBE networks are the largest equilibrium networks in the number of links. Then, can derive an even stronger statement, every Nash equilibrium network that is not an MBE network is Pareto dominated by the MBE network closest to it.

Lemma A.2. *If for every i, j we have $w_{ij} = w$ for some $w \in \mathbb{R}_+$, then for every $x' \in X^* \setminus V^*$ and every $x \in V^*$ that is closest to x' in V^* , x Pareto dominates x' .*

Proof: Let $x' \in X^* \setminus V^*$, let x be an element of V^* that is closest to x' , and assume that x does not Pareto dominate x' . Then, there exists $i \in I$ such that $\deg_i(x') > \deg_i(x)$. Hence, there exists a player $j \in N_i(x') \setminus N_i(x)$. If $\deg_j(x) < \deg_j(x')$, then either $\deg_j(x) < d_j$ and hence, $\{i, j\}$ could be added to x , contradicting $x \in V^*$, or we have $\deg_j(x') > d_j = \deg_j(x)$, contradicting the fact that x' is an equilibrium network.

If $\deg_j(x) > \deg_j(x')$, then there must exist $k \in N_j(x) \setminus N_j(x')$. Consider the network x'' which we get from x by removing the link $\{j, k\}$ and adding the link $\{i, j\}$. It is clear that $x'' \in X^*$, since $\deg_i(x'') \leq \deg_i(x') \leq d_i$, $\deg_j(x'') = \deg_j(x') = d_j$, and $\deg_k(x'') = \deg_k(x) - 1 < d_k$. Furthermore, $x'' \in V^*$, since x has the same number of links as x'' . However, we have $\phi(x', x'') = \phi(x', x) - 2$, thus we contradict the choice of x as a closest element of V^* to x' . Thus, x must Pareto dominate x' . ■

There is no equivalent statement for games with aligned preferences in general as a player i 's first-best network need not be an MBE network and thus it is possible for this player to be worse off in every MBE network.

As finding MBE is computationally demanding, checking whether preferences are aligned in a game is difficult as well. We conclude this section by deriving a set of sufficient conditions under which a game's unique MBE network is monotonic, which in turn implies that preferences are aligned.

Lemma A.3. *Suppose that*

1. *for every $i \in I$ there exists a value \bar{w}_i such that $|\{k: w_{ik} \geq \bar{w}_i\}| = d_i$, and*
2. *for every $i, j \in I$ we have $w_{ij} \geq \bar{w}_i \Leftrightarrow w_{ij} \geq \bar{w}_j$.*

Let x^ be given as follows: $x_{ij}^* = 1$ if $w_{ij} \geq \bar{w}_i$, $x_{ij}^* = 0$ otherwise. Then, x^* is the unique MBE network and it is monotonic.*

Proof: It is clear that x^* is monotonic and, by property (2), it is undirected. Furthermore, by property (1) it holds that for every $i \in I$ we have $\deg_i(x^*) = d_i$. Thus, every player has the maximum number of neighbors and is linked to her best choice of d_i opponents. Thus, x^* is the only MBE network.

■

Lemma A.3 lays out two sufficient conditions for preferences to be aligned: (1) each player must have a well-defined set of ‘favorite’ opponents to link to that will satiate her, and (2) reciprocity in ‘favorite’ opponents. The first condition precludes, among other settings, the uniform benefits case; even though uniform benefits represent aligned preferences they do not generally imply uniqueness of the MBE network. If indifferences are not allowed, as is often the case in matching where individuals have a strict ranking of opponents, this condition is automatically satisfied. The second condition ensures reciprocity of links if all players link to their set of favorite opponents and is the main restrictive condition in the lemma. These conditions are strong but, given the matrix of weights, easy to check.

A.2 Proofs for Section 3

Lemma 3.1

The \Leftarrow direction is clear; if the link towards a player j appears profitable and there is no better alternative to connect to, then player i 's best response is to link to j . The \Rightarrow direction consists of two simple parts: (1) linking to j cannot be a best response if it does not appear profitable, (2) linking to j but not linking to an apparently more profitable k cannot be a best response.

■

Proposition 3.3

We show this statement by the use of strict best-response paths. A strict best-response path is a sequence of networks $(x^t)_{t \in \{0, \dots, T\}}$ such that for every $t \in \{1, \dots, T\}$ there exists a player i^t such that $x_{-i^t}^t = x_{-i^t}^{t-1}$, $x_{i^t}^{t-1} \notin B_i(\nu_i(\cdot | \alpha_i, \delta_i, x^t))$,

and $x_{it}^t \in B_i(\nu_i(\cdot|\alpha_i, \delta_i, x^t))$. In a strict best-response path every period has exactly one player move from a strategy that isn't a best response to the current strategies of her opponents to a best response. We will show that no matter the starting network x^0 , the order of updates, or the length of the sequence, there are no cycles in this process, i.e. there does not exist a non-trivial strict best-response path for which $x^0 = x^T$. Given this fact and due to the finiteness of the set of possible networks with n players, starting from any network, any sequence of such strict improvements by players who are not at their best response will lead to an EUA.

So, for contradiction suppose that such a cycle $(x^t)_{t \in \{0, \dots, T\}}$ exists with $x^0 = x^T$. We say that the link $\{i, j\}$ is *changing* in this sequence if there exist two time periods t and t' such that $x_{ij}^t \neq x_{ij}^{t'}$. It is clear that such links must exist in any strict best-response path.

Claim A.4. *In a strict best-response cycle there must exist a changing link $\{i, j\}$ and a time period t such that $x_{ij}^t = x_{ji}^t = 1$.*

To show this, suppose for contradiction that such a changing link does not exist. Take a player i and two distinct time periods $t < t'$ such that $i^t = i^{t'} = i$ and for every $t'' \in \{t + 1, \dots, t' - 1\}$ we have $i^{t''} \neq i$. For any cycle such periods may be found by an appropriate time shift. It is clear that t and t' cannot be consecutive time periods in a strict best-response path and that there must exist a link $\{i, j\}$ such that $x_{ij}^{t+1} \neq x_{ij}^{t'+1}$ otherwise $x_i^t = x_i^{t'+1}$, contradicting that $x_i^t \notin B_i(\nu_i(\cdot|\alpha_i, \delta_i, x^t))$. Since there are no changing reciprocal links we must have $N_i(x^t) = N_i(x^{t+1}) = N_i(x^{t'}) = N_i(x^{t'+1})$. Furthermore, for every $k \in I$ with $x_{ik}^t = 0$ and $x_{ki}^t = 1$ we have $x_{ik}^{t+1} = 0$, otherwise a changing reciprocal link would appear. Similarly, for every $k \in I$ with $x_{ik}^{t'} = 0$ and $x_{ki}^{t'} = 1$ we have $x_{ik}^{t'+1} = 0$.

It follows that $x_i^{t+1} \in B_i(\nu_i(\cdot|\alpha_i, \delta_i, x^t))$ implies $x_i^{t'+1} \in B_i(\nu_i(\cdot|\alpha_i, \delta_i, x^t))$ as no player can form a link to i , nor delete a link to i that she would reciprocate

forming or deleting in t' as there can be no changing reciprocated links. Since $x_i^{t+1} = x_i^{t'}$ due to the fact that i hasn't changed her action between t and t' we have $x_i^{t'} \in B_i(\nu_i(\cdot|\alpha_i, \delta_i, x^t))$, a contradiction by the fact that we assumed a strict best-response cycle.

■

Secondly, we show that a strict best-response cycle also cannot contain a reciprocated changing link. The two statements together imply that there are no strict best-response cycles.

Claim A.5. *In a strict best-response cycle there cannot be a changing link $\{i, j\}$ and a time period t such that $x_{ij}^t = x_{ji}^t = 1$.*

Once again, suppose for contradiction that such a link exists in a strict best-response cycle. Let i, j be a pair and t a time period such that $\{i, j\}$ is a reciprocated changing link with the largest value w_{ij} , $i^t = i$, $x_{ij}^t = x_{ji}^t = 1$, $x_{ij}^{t+1} = 0$, and $|\{k \in N_i(x^t): w_{ik} = w_{ij}\}| \geq |\{k \in N_i(x^{t+1}): w_{ik} = w_{ij}\}|$. In words, i, j is a best-value reciprocated changing link that was deleted by i in period t and she does not have more links of value w_{ij} in period $t + 1$ than in period t . Such i, j and t are guaranteed to exist in a strict best-response cycle.

Let time period $t' < t$ be such that $i^{t'} = i$, $x_{ij}^{t'} = 0$, $x_{ij}^{t'+1} = 1$. As before, for any cycle, such periods may be found by an appropriate time shift.

Let $K_i = \{k: w_{ik}\alpha_i\delta_i > w_{ij}\alpha_i\delta_i + 1 - \delta_i\}$ denote the set of players whom i strictly prefers to j even if j reciprocates but they do not. If this set is empty, player i will never delete a link with j . It is clear that we must have $x_{ik}^{t'+1} = 1$ for every $k \in K_i$, otherwise we cannot have $x_{ij}^{t'+1} = 1$ as a best response to $x^{t'}$ by Lemma 3.1. This in turn implies that $x_{ik}^t = 1$ for every $k \in K_i$, otherwise we would have a time period $t'' \in \{t' + 1, \dots, t - 1\}$ where i deletes her link to a $k \in K_i$ but keeps the link to j , which cannot happen in a best response.

So, at time t , when i deletes her link to j , every link that offers a better payoff was already formed, and since she cannot have more neighbors of equal value in $t + 1$ by the choice of j , it is impossible that x_i^{t+1} is a best response to x^t provided that x_i^t was not a best response to x^t . This concludes the proof of Claim A.5 and thus of Proposition 3.3. ■

Proposition 3.5

The statement follows from the fact that for every $i, j \in I$ and every $x_{-i} \in X_{-i}$ it holds that $w_{ij}(\alpha_i \delta_i + x_{ji}(1 - \delta_i)) \geq w_{ij}(\alpha'_i \delta_i + x_{ji}(1 - \delta_i))$, thus in best response to both situations, more optimism will lead to a weakly higher number of out-links. ■

Proposition 3.7

We decompose the network formation game with parameters (δ, α') into two parts: the mutual links that are formed in the equilibrium x of the game (δ, α) , $y(x)$ and the remaining links. In particular, we will look at the network formation game with parameters (δ, α') such that

$$\begin{aligned} \tilde{w}_{ij} &= 0 \text{ for all } \{i, j\} \in y(x) & (3) \\ \tilde{w}_{ij} &= w_{ij} \text{ for all } \{i, j\} \notin y(x) \\ \tilde{c}_i(r) &= c_i(r + \deg_i(x)) \text{ for } r \in \mathbb{N}, i \in I \end{aligned}$$

Clearly, for every $i \in I$ the maximal number of links in this game is given by $\tilde{d}_i = \bar{d}_i - \deg_i(x)$. Furthermore, by Proposition 3.3, this game has an equilibrium – denote such an equilibrium by \tilde{x} . Note that since $\tilde{c}_i(r) > 0$ for all r , $\tilde{x}_{ij} = 0$ holds for all $\{i, j\} \in y(x)$.

For the original game with parameters (δ, α') , define the strategy combination x' by $x'_{ij} = 1$ for all $\{i, j\} \in y(x)$ and $x'_{ij} = \tilde{x}_{ij}$ for all $\{i, j\} \notin y(x)$. Note that for each i ,

$$\deg_i^+(x') = \deg_i^+(\tilde{x}) + \deg_i(x) \quad (4)$$

We now show that $x' \in X^*(\delta, \alpha')$ by showing that x'_i satisfies the two conditions in Lemma 3.1, i.e. it is a best response to x'_{-i} , starting with condition 1. Take an $\{i, j\}$ such that $x'_{ij} = 1$.

Case 1: If $\{i, j\} \in y(x)$, and there exists some k such that $x'_{ik} = 1$ and $\{i, k\} \notin y(x)$, then we have

$$w_{ij} [\alpha'_i \delta_i + (1 - \delta_i) x'_{ji}] \geq w_{ik} [\alpha'_i \delta_i + (1 - \delta_i) x'_{ki}] > \tilde{c}'_i(\deg_i^+(\tilde{x})) = c'_i(\deg_i^+(x')),$$

where the first inequality follows from the fact that x is monotonic and thus $w_{ij} \geq w_{ik}$, the second inequality follows from the fact that $x'_{ki} = \tilde{x}_{ki}$ and \tilde{x} is an equilibrium of (3) and the equality is a consequence of the definition of \tilde{c} and (4).

Case 2: If $\{i, j\} \in y(x)$ and $N_i^+(x') = N_i(x)$ then we have

$$w_{ij} [\alpha'_i \delta_i + (1 - \delta_i)] \geq w_{ij} [\alpha_i \delta_i + (1 - \delta_i)] > c'_i(\deg_i(x)) = c'_i(\deg_i^+(x')),$$

where the first inequality is due to $\alpha'_i \geq \alpha_i$, the second is due to the fact that $\{i, j\} \in y(x)$ and x was an EUA of the game with α , and the equality is by the definition of \tilde{c} and (4).

Case 3: If $\{i, j\} \notin y(x)$, then $x'_{ij} = \tilde{x}_{ij}$

$$w_{ij} [\alpha'_i \delta_i + (1 - \delta_i) x'_{ji}] > \tilde{c}'_i(\deg_i(\tilde{x})) = c'_i(\deg_i(x)),$$

where the inequality holds due to the fact that \tilde{x} is an equilibrium of (3) and the equality is a consequence of the definition of \tilde{c} and (4).

Thus, condition 1 of Lemma 3.1 is satisfied whenever $x'_{ij} = 1$.

Take next an $\{i, j\}$ such that $x'_{ij} = 0$. Clearly, $\{i, j\} \notin y(x)$ and thus $x'_{ij} = \tilde{x}_{ij}$. Since \tilde{x}_{ij} is an equilibrium of the game defined by (3), we have

$$w_{ij} [\alpha'_i \delta_i + (1 - \delta_i) x'_{ji}] < \tilde{c}'_i (\deg_i^+ (\tilde{x})) = c'_i (\deg_i^+ (x')).$$

Thus, condition 1 of Lemma 3.1) is satisfied whenever $x'_{ij} = 0$ as well.

Finally, we check condition 2. Suppose that there exist distinct players i, j and k such that $w_{ij}(\alpha'_i \delta_i + (1 - \delta_i)x'_{ji}) > w_{ik}(\alpha'_i \delta_i + (1 - \delta_i)x'_{ji})$, but $x'_{ik} = 1$ and $x'_{ij} = 0$. Clearly, $\{i, j\} \notin y(x)$. If $\{i, k\} \in y(x)$ then $x'_{ki} = 1$, and since $w_{ik} \geq w_{ij}$ by the fact that x is monotonic, this contradicts $w_{ij}(\alpha'_i \delta_i + (1 - \delta_i)x'_{ji}) > w_{ik}(\alpha'_i \delta_i + (1 - \delta_i)x'_{ji})$. Hence, $\{i, k\} \notin y(x)$. Since \tilde{x} is an EUA of the game (3), by condition 2 of Lemma 3.1 we have

$$\begin{aligned} w_{ij} [\alpha'_i \delta_i + (1 - \delta_i) \tilde{x}_{ji}] &= w_{ij} [\alpha'_i \delta_i + (1 - \delta_i) x'_{ji}] \leq \\ &w_{ik} (\alpha'_i \delta_i + (1 - \delta_i) x'_{ji}) = w_{ik} (\alpha'_i \delta_i + (1 - \delta_i) \tilde{x}_{ji}), \end{aligned}$$

a contradiction.

Therefore, all conditions of Lemma 3.1 holds. ■

A.3 Proofs for Section 4

Lemma 4.3

Proof: Take an $x^* \in V^*$. For contradiction, assume an $x \in X^*$ exists that Pareto dominates x^* . Suppose that for every $i \in I$ we have $\deg_i(x) \geq \deg_i(x^*)$. Then, for every $i \in I$ we have $c_i(x) \geq c_i(x^*)$, thus, for $u_i(x) \geq u_i(x^*)$ to hold we must have $\sum_{j \in N_i(x)} w_{ij} \geq \sum_{j \in N_i(x^*)} w_{ij}$, for each $i \in I$ and strict inequality for at least one player, contradicting the weight-maximality of x^* . Thus, there exists a player i with $\deg_i(x) < \deg_i(x^*)$. However, since x^* is monotonic, $u_i(x) \geq u_i(x^*)$ requires $\deg_i(x) \geq \deg_i(x^*)$, a contradiction.

■

Proposition 4.4

We first prove a supporting statement.

Lemma A.6. *Suppose that the players exhibit aligned preferences. For a $T \in \mathbb{N}$ let $(x^t)_{t \in \{0, \dots, T\}}$ be a finite sequence of networks obeying the defined updating rule such that $x^0 \in V^*$ and $x^t \in y^{-1}(V^*)$ for $t \in \{0, \dots, T\}$. Then, for every $t \in \{0, \dots, T\}$ and every $i \in I$ we have $w'_i(x^t) > c'_i(d_i)$.*

Proof: Suppose that we have $w'_i(x^t) < c'(d_i)$. Let t denote the first such period, i.e. $x_i^t \in B_i(x^t)$ or $x_i^t \in B_i^o(x^t)$. It is clear that the latter is impossible as optimistic players never initiate or accept such links, thus we must have $x_i^t \in B_i(x^t)$. Since $y(x^t) \in V^*$ and since preferences are aligned x_i^t is monotonic for i . This means that for every k such that $w'_i(x^t) < w_{ik}$ we have $\{i, k\} \in x^t$. However, by the definition of d_i , this has to imply $\deg_i^+(x) > d_i$, which is also impossible as a best-responding player would not initiate more than d_i links.

■

Proof of Proposition 4.4: We first show that $y(x') \in X^*$. Take a sequence $(x^t)_{t \in \{0, \dots, T\}}$ obeying the defined updating rule with $x^0 \in V^*$. Since x^0 is a Nash equilibrium, then by the updating rule, for every x^t we have $w'_{it}(x^t) > c'_{it}(\deg_{it}(x^t))$. Thus, for every $t' \in \{0, \dots, T\}$ and every $i, j \in I$ with $x'_{ij} = x'_{ji} = 1$ we have $w_{ij} > c'_i(\deg_i^+(x^{t'})) \geq c'_i(\deg_i(x^{t'}))$, satisfying the conditions of a Nash equilibrium.

Thus, for contradiction, suppose that $x' \in S(x^*)$ and $y(x') \notin V^*$. Then we must have $v(x') < v(x^*)$, as $v(x') = v(y(x')) > v(x^*)$ would contradict the choice of x^* as a maximum-benefit equilibrium, while $v(x') = v(x^*)$ would imply $y(x') \in V^*$. Thus, the value of the network must decrease along the sequence between x^* and

x' . Suppose that x' is the earliest element of the sequence with $v(x') < v(x^*)$, let x denote the element immediately preceding it and let i denote the player who updated between x and x' , i.e. $x_{-i} = x'_{-i}$. Since $v(x) > v(x')$ there must exist $\{i, j\} \in x \setminus x'$ and by Lemma A.6 it must satisfy $w_{ij} > c'_i(d_i)$.

Suppose that $x'_i \in B_i(x)$. Then, since i drops her link with j as a best response even though j reciprocates, we must have $w_{ij} < c'_i(\deg_i^+(x') + 1) = c'_i(\deg_i(x') + 1)$. Thus, $\deg_i(x') + 1 > d_i$, meaning that $\deg_i(x') = d_i$. Since i made a best response, $u_i(x) \leq u_i(x')$, and since the number of neighbors in x' is at maximum, and thus the weak increase in utility did not come through a decrease in costs, the total value of i 's links must have weakly increased from x to x' . Hence, we have

$$v(x) = \sum_{j \neq i} w_{ij} x_{ij} x_{ji} + \sum_{j \neq k \neq i} w_{jk} x_{jk} x_{kj} \geq \sum_{j \neq i} w_{ij} x'_{ij} x_{ji} + \sum_{j \neq k \neq i} w_{jk} x_{jk} x_{kj} = v(x'),$$

a contradiction to $v(x') < v(x)$.

Suppose that $x'_i \in B_i^o(x)$. Then, since x'_i is monotonic for i and i drops her link with j , $\deg_i^+(x') = d_i$. Since $w_{ij} > c'_i(d_i)$, and yet i chose not to reciprocate j 's link, there must exist $k \in I$ with $w_{ij} = w_{ik}$ such that $\{i, k\} \in x'$. Since $y(x)_i$ is monotonic, and $\{i, j\} \in x$ for every $\ell \in I$ with $w_{i\ell} > w_{ij}$ we have $\{i, \ell\} \in x$. Since x'_i is monotonic for i , $\{i, \ell\} \in x'$ as well. Furthermore, for every $\ell \in I$ with $w_{ij} = w_{i\ell}$ and $x'_{i\ell} = 1$ we must have $x'_{\ell i} = x_{\ell i} = 1$ as well, otherwise deleting a link to an unreciprocated opponent of equal value is better for i than deleting her link to j . Thus, $\deg_i^+(x') = \deg_i(x') = d_i$. Finally, x'_i being monotonic means that i has a reciprocal link to exactly d_i of her most favored opponents. So as before we have

$$v(x) = \sum_{j \neq i} w_{ij} x_{ij} x_{ji} + \sum_{j \neq k \neq i} w_{jk} x_{jk} x_{kj} \geq \sum_{j \neq i} w_{ij} x'_{ij} x_{ji} + \sum_{j \neq k \neq i} w_{jk} x_{jk} x_{kj} = v(x'),$$

a contradiction to $v(x') < v(x)$.

■

Proposition 4.5

Lemma A.7. *For every $x \in X$ there exists $x^* \in X^* \cap S(x)$ such that for all $i \in I$ we have $w'_i(x^*) > c'_i(d_i)$.*

Proof: First we show that there exists $x' \in X^* \cap S(x)$. Take an arbitrary $x \in X$. Then, suppose that in the next n periods, all players $\{1, \dots, n\}$ are given an ambiguity-neutral best-responding revision opportunity in increasing order. Call the resulting network x' . The probability of this happening is $((1 - \beta)/n)^n > 0$, so we must have $x' \in S(x)$. Then, for every $i \in I$ we have $w'_i(x') > c'_i(\deg_i^+(x'))$ and for every pair with $i > j$ we can have $x'_{ij} = 1$ only if $x_{ji} = 1$. Thus, repeating the same process in the reverse order will lead to an undirected network x'' with $w'_i(x'') > c'_i(\deg_i(x''))$ for all $i \in I$, satisfying the equilibrium conditions.

This shows that we can take $x \in X^*$ at the start. Take a player i such that $w'_i(x) < c'_i(d_i)$. If none can be found, we are done. If such a player exists, suppose that she receives an optimistic revision opportunity. Then since for every $x_i^o \in B_i^o(x)$ we have $w'_i(x_i^o, x_{-i}) > c'_i(d_i)$, she will sever all links with players giving her less benefits than $c'_i(d_i)$ and possibly initiate some links to others. Then, allow all her neighbors with whom she severed her links to best-respond in an ambiguity-neutral way, their only best response being is to sever their unreciprocated links towards i and make no other changes. Finally, let player i best-respond to sever all unreciprocated links she had initiated as an optimist. Call the resulting network x' . Since $p^m(x, x') > 0$ for some $m \leq N_i(x) + 1$ we must have $x' \in S(x)$.

At x' , we clearly have $w'_i(x') > c'_i(d_i)$ since all players $j \neq i$ with $w_{ij} < c'_i(d_i)$ now have no outgoing links towards i while $N_i(x) \supseteq N_i(x')$. Thus, we have $x'_i \in B_i(x')$, meaning that $x' \in X^*$. Furthermore, $w'_i(x') > c'_i(d_i)$, as well as $|x'| < |x|$, since player i lost links and no player gained any. If there exists $j \neq i$

with $w'_j(x') < c'_j(d_j)$, we can repeat this process. If the process does not terminate sooner with a desired network, it will terminate by reaching the empty network which trivially satisfies the conditions of the statement of the lemma. ■

The next lemma shows that the learning process enters the set of maximum-benefit equilibria that are monotonic, V^* , for any starting state with a positive probability.

Lemma A.8. *Suppose that the players exhibit aligned preferences. For every $x \in X$ there exists an $x^* \in V^* \cap S(x)$.*

Proof: By Lemma A.7 we may take $x \in X^*$ such that $w'_i(x) > c'_i(d_i)$ for all $i \in I$. Let $x^* \in V^*$ be the closest element of V^* to x . If $x \geq x^*$, then we must have $x = x^*$ otherwise we contradict the choice of x^* as an element of V^* , in which case we are done. If $x \not\geq x^*$, we have $x^* \setminus x \neq \emptyset$.

We will show that there exists an $x'' \in X^* \cap S(x)$ which also satisfies $w'_i(x'') > c'_i(d_i)$ for every $i \in I$ and for which $\phi(x'', x^*) < \phi(x, x^*)$. Through a repeated application of this argument the distance eventually decreases to 0, meaning that we reach x^* . We distinguish two cases.

Case 1. There exists a player i and a link $\{i, j\} \in x^* \setminus x$ such that $\deg_i(x) < d_i$. Let $j \in \operatorname{argmax}_{j' \in N_i(x^*) \setminus N_i(x)} w_{ij'}$ be the most valuable such link for player i . Then let x'_i be a strategy profile which is monotonic for i , $\deg_i^+(x'_i, x_{-i}) = d_i$, and $N_i^+(x'_i, x_{-i}) \supseteq (N_i(x) \cap N_i(x^*)) \cup \{j\}$. By Lemma 3.1, and due to x satisfying $w'_i(x) > c'_i(d_i)$, we must have $x'_i \in B_i^o(x)$. Let player i receive an optimistic revision opportunity and suppose that she revises to x'_i .

Case 1a. If $\deg_j(x) < d_j$, then we must have $w_{ij} \geq w'_j(x^*) > c'_j(d_j) \geq c'_j(\deg_j(x) + 1)$. Therefore, $B_j(x'_i, x_{-i})$ is a singleton with its only element, which we denote by x'_j , satisfying $x'_{jk} = 1$ if and only if $k \in N_j(x) \cup \{i\}$. Suppose

that player j receives a best-responding revision opportunity, and thus, selects the strategy x'_j . For each $k \in N_i(x) \setminus N_i^+(x'_i, x_{-i})$ let k receive a best-responding revision opportunity, their only best response being is to keep all of their existing links except those with i who had severed her link to each k .

Finally, let player i also receive best-responding revision opportunity. Her only best response, which we denote by x''_i , is to delete all unreciprocated links she initiated when she moved to x'_i , that is, $x''_{ik} = 1$ if and only if $k \in (N_i(x) \cap N_i(x^*)) \cup \{j\}$. Let the resulting network be denoted by x'' . It is clear that x'' is an equilibrium network, $w'(x'') \geq c'(d)$, and $\phi(x'', x^*) < \phi(x, x^*)$. Since the above process leads to x'' from x , we have $x'' \in S(x)$ as well.

Case 1b. If $\deg_j(x) = d_j \geq \deg_j(x^*)$, then there must exist a link $\{j, k\} \in x \setminus x^*$. Since x^* is monotonic we must also have $w_{ij} \geq w_{jk}$. Thus, there must exist an $x'_j \in B_j(x'_i, x_{-i})$ such that $x'_{j\ell} = 1$ if and only if $\ell \in (N_j(x) \setminus \{k\}) \cup \{i\}$. As before let j receive a best-responding revision opportunity and suppose that she selects x'_j . Let this be followed by player k best-responding; her only best response being to cut her now unreciprocated link towards j and keeping all her other neighbors.

Then, as before, for each $k' \in N_i(x) \setminus N_i^+(x'_i, x_{-i})$ let k' receive a best-responding revision opportunity, their only best response being to keep all of their existing links except those with i , who had severed her link to each k' . Finally, let i best-respond, her only best response being to delete all unreciprocated links she initiated when she moved to x'_i , that is, $x''_{ik} = 1$ if and only if $k \in (N_i(x) \cap N_i(x^*)) \cup \{j\}$. Let the resulting network be denoted by x'' . As before, $x'' \in X^*$, satisfies $w'(x'') \geq c'(d)$ and $\phi(x'', x^*) < \phi(x, x^*)$, as well as $x' \in S(x)$, completing Case 1.

Case 2. For every link $\{i, j\} \in x^* \setminus x$ we have $\deg_i(x) = d_i$ and $\deg_j(x) = d_j$. We will show that there must exist such a link $\{i, j\}$ for which there exists $\{i, k\} \in x \setminus x^*$ such that $w_{ij} > w_{ik}$.

Suppose this is not true, i.e. for every i, j, k with $\{i, j\} \in x^* \setminus x$ and $\{i, k\} \in x \setminus x^*$ we have $w_{ij} \leq w_{ik}$. Since $\deg_i(x) = d_i$ for all i with $N_i(x) \neq N_i(x^*)$ we must have $\deg_i(x) \geq \deg_i(x^*)$ for all i . These two facts imply that $v(x) \geq v(x^*)$ which can only hold with equality as x^* is a maximum-benefit equilibrium network. If $\deg_i(x) > \deg_i(x^*)$ for some $i \in I$ and $\deg_j(x) \geq \deg_j(x^*)$ for all other $j \neq i$, then $v(x) = v(x^*)$ can hold only if we have such a trio i, j, k with $\{i, j\} \in x^* \setminus x$, $\{i, k\} \in x \setminus x^*$, and we have $w_{ij} > w_{ik}$, a contradiction. So suppose that $\deg_i(x) = \deg_i(x^*)$ for all i .

Now we will show that under these conditions x is monotonic, a contradiction since that would mean $x \in V^*$. Take a player i and suppose that there exist $j, k \neq i$ such that $\{i, j\} \in x$, $\{i, k\} \notin x$ and $w_{ij} < w_{ik}$. If no such player can be found, x is monotonic. We must have $\{i, k\} \notin x^*$ by assumption thus $\{i, k\} \in x \setminus x^*$. However, due to $\deg_i(x) = \deg_i(x^*)$ there must exist an $\ell \in N_i(x^*) \setminus \{j\}$ and by assumption we must have $w_{ik} > w_{ij} \geq w_{i\ell}$. Thus, since $\{i, k\} \notin x^*$, this is a contradiction as x^* is monotonic.

Therefore if for every link $\{i, j\} \in x^* \setminus x$ we have $\deg_i(x) = d_i$ and $\deg_j(x) = d_j$, then there must exist $\{i, j\} \in x^* \setminus x$ and a $\{i, k\} \in x \setminus x^*$ such that $w_{ij} > w_{ik}$. In particular, let $j \in \operatorname{argmax}_{j' \in N_i(x^*) \setminus N_i(x)} w_{ij'}$ and let $k \in \operatorname{argmin}_{j' \in N_i(x) \setminus N_i(x^*)} w_{ij'}$.

Construct a strategy x'_i such that it is monotonic and for every $\ell \in (N_i(x) \cap N_i(x^*)) \cup \{j\}$ we have $x'_{i\ell} = 1$. By the fact that $w_{ij} > w_{ik}$, we must have such a strategy with $\deg_i^+(x'_i, x_{-i}) = d_i$ as player i can include j to her set of neighbors and exclude k and still maintain an out-degree of d_i . By Lemma 3.1, we have $x'_i \in B_i^o(x)$. As in Case 1, let i receive an optimistic revision opportunity and suppose she picks the optimistic best response x'_i . From here by the same process as in Case 1b we can reach $x'' \in X^* \cap S(x)$ with $w'(x'') > c'(d)$ and $\phi(x'', x^*) < \phi(x, x^*)$. ■

Finally, given that we reach V^* , the proof of the Proposition itself follows

simply from Proposition 4.4.

Proof of Proposition 4.5. By Lemma A.8 for every $x \in X$ we have a $x^* \in V^*$ with $x^* \in S(x)$. Since there are finitely many networks, with probability one, the process enters V^* and thus $y^{-1}(V^*)$. By Proposition 4.4, the game never leaves $y^{-1}(V^*)$. ■

Proposition 4.8

As before, we first show that the dynamic system will take the game into V^* , which is a unique network x^* in the linear case.

Lemma A.9. *Let the cost functions be linear. For every $x \in X$ and the unique $x^* \in V^*$ we have $x^* \in S(x)$.*

Proof: By Lemma A.7 we can take $x \in X^*$. We show that if $x = x^*$ there exists $x' \in S(x) \cap X^*$ such that $\phi(x', x^*) < \phi(x, x^*)$. Take a link $\{i, j\} \in x^* \setminus x$. Then, we must have $w_{ij} > \max\{c_i, c_j\}$. Take the following series of updates: i receives a revision opportunity as an optimist, j receives a revision opportunity as a best-responder, then i receives a revision opportunity as a best-responder. It is clear that an optimistic player i will link to j , as well as keep all of her links to her neighbors in x . A best-responder j will make no changes except reciprocate player i 's link. Finally, player i deletes all the unreciprocated links she made as an optimist. For the resulting network, $x' = x \cup \{i, j\}$, we have $x' \in X^*$ as well as $\phi(x', x^*) = \phi(x, x^*) - 1$. ■

Secondly, we show that once x^* is reached, the game never leaves the set $y^{-1}(x^*)$.

Lemma A.10. *Let the cost functions be linear. For the unique $x^* \in V^*$ we have $S(x^*) \subseteq y^{-1}(x^*)$.*

Proof: Suppose for contradiction that there exist a pair $x, x' \in S(x^*)$ such that $x \in y^{-1}(x^*)$, $x' \in S^1(x)$, and $x' \notin y^{-1}(x^*)$. Then, there must exist $\{i, j\} \in x' \setminus x$, with $w_{ij} > \max\{c_i, c_j\}$. Clearly, one of i and j must have updated to get from x to x' so suppose it was i , i.e. $x_{-i} = x'_{-i}$. If $x'_i \in B_i(x)$, then, since $x'_{ji} = x_{ji} = 1$, deleting the link to j cannot be a best response. If $x'_i \in B_i^o(x)$, then, since $w_{ij} > c_i$, deleting the link to j cannot be an optimistic best response, so we have arrived at a contradiction.

This completes the proof of the proposition. ■

References

- Acemoglu, D., Aghion, Ph., Zilibotti, F., 2006. Distance to Frontier, Selection and Economic Growth, *Journal of the European Economic Association* 4: 37-74.
- Andersson, M. A., 2015. Dispositional optimism and the emergence of social network diversity. *The Sociological Quarterly* 53: 92-115.
- Baillon, A., Koellinger, P. D., Treffers, T., 2013. Sadder but wiser: The effects of emotional states on ambiguity attitudes. *Journal of Economic Psychology* 53: 67-82.
- Bala, V., Goyal, S., 2000. A non-cooperative model of network formation. *Econometrica* 68: 1181-1230.
- Baumann, L., 2019. A model of weighted network formation.
SSRN: <https://ssrn.com/abstract=2533533>.
- Bauchene, D., 2014. Games and ambiguity: a survey. Working paper.
- Bengtsson, O., Sanandaji, T., Johannesson, M., 2012. Do Women Have a Less Entrepreneurial Personality?, IFN Working Paper No. 944.

- Bloch, F., Dutta, B., 2009. Communication networks with endogenous link strength. *Games and Economic Behavior* 66: 39-56.
- Bloch, F. and Jackson, M.O., 2006. Definitions of equilibrium in network formation games. *International Journal of Game Theory*, 34: 305-318.
- Bogliacino, F., Gallo, I., 2015. Aspirations, prospect Theory and entrepreneurship: evidence from Colombia, *International Review of Economics* 62: 271-290.
- Brissette, I., Scheier, M. F., Carver, C. S., 2002. The role of optimism in social network development, coping, and psychological adjustment during a life transition. *Journal of Personality and Social Psychology* 82:102-111.
- Brueckner, J., 2006. Friendship Networks, *Journal of Regional Science* 46: 847–865.
- Camerer, C. F., Karjalainen, R., 1994. Ambiguity-aversion and non-additive beliefs in non-cooperative games: experimental evidence. In: Munier, B. R., Machina, M. M. (eds.), *Models and experiments in risk and rationality*, Berlin, Springer: 325-358.
- Chateauneuf, A., Eichberger, J., and Grant, S., 2007. Choice under uncertainty with the best and the worst in mind: NEO-additive capacities. *Journal of Economic Theory* 137, 538-567.
- Collard, F., Mukerji, S., Sheppard, K., Tallon, J.-M., 2011. Ambiguity and the historical equity premium. *Economics Series Working Paper 550*, University of Oxford, Department of Economics.
- Cooper, R., DeJong, D. V., Forsythe, R., Ross, T. W., 1990. Selection criteria in coordination games. *American Economic Review* 80: 218-233.

- Dawid, H., Hellman, T., 2014. The evolution of R&D networks. *Journal of Economic Behavior and Organization* 105: 158-172.
- Di Mauro, C., Castro, M. F., 2008. Kindness confusion or ... ambiguity? Working Paper, Universita di Catania.
- Ding, S., 2019. The formation of links and the formation of networks. Mimeo.
- Dollinger, M. J., Saxton, T., Golden, P. A., 1995. Intolerance of ambiguity and the decision to form an alliance, *Psychological reports*, 77: 1197-1198.
- Dutta, B., Mutuswami, S., 1997. Stable networks, *Journal of Economic Theory* 76: 322-344.
- Eichberger, J., Kelsey, D., 2000. Non-additive beliefs and strategic equilibria. *Games and Economic Behavior* 30: 183-215.
- Eichberger, J., Kelsey, D., 2002. Strategic complements, substitutes and ambiguity: The implications for public goods. *Journal of Economic Theory* 106: 436-466.
- Eichberger, J., Kelsey, D., 2014. Optimism and pessimism in games. *International Economic Review* 55: 483-505.
- Eichberger, J., Kelsey, D., Schipper, B., 2008. Granny versus game theorist: ambiguity in experimental games. *Theory and Decision* 64: 333-362.
- Eichberger, J., Guerdjikova, A., 2018. Do markets prove pessimists right? *International Economic Review* 59: 2259-2295.
- Ellsberg, D., 1961. Risk, ambiguity and the savage axioms. *Quarterly Journal of Economics* 75: 643-669.

- Ely, J. C., 2002. Local conventions. *The B.E. Journal of Theoretical Economics* 2: 1-32.
- Fafchamps, M., van der Leij, M. J., Goyal, S., 2006. Scientific networks and co-authorships, University of Oxford, Department of Economics Discussion Paper Series, No. 256.
- Fredrickson, B.L., 2001. The role of positive emotions in positive psychology: The broaden-and-build theory of positive emotions. *American Psychologist*, 56: 218.
- Freud, S., 1928. *The future of an illusion*. London, Hogarth.
- Galeotti, A., Goyal, S., 2010. The law of the few. *American Economic Review* 100: 1468-1492.
- Gilboa, I., Schmeidler, D., 1989. Maxmin expected utility with a non-unique prior. *Journal of Mathematical Economics* 18: 141-153.
- Goyal, S., Joshi, S., 2003. Networks of collaboration in oligopoly, *Games and Economic Behavior* 43: 57-85.
- Goyal, S. and Vega-Redondo, F., 2005. Learning, network formation and coordination. *Games and Economic Behavior* 50: 178-207.
- Goyal, S., Vega-Redondo, F. 2007. Structural holes in social networks, *Journal of Economic Theory* 137: 460-492.
- Griffith, A., 2019. A continuous model of strong and weak ties. Mimeo.
- Guerdjikova, A., Sciubba, E., 2015. Survival with ambiguity. *Journal of Economic Theory* 155: 50-94.
- Harsanyi, J., Selten, R., 1988. *A general theory of equilibrium selection in games*. Cambridge, Cambridge University Press.

- Hellman, T., Staudigl, M., 2012. Evolution of social networks. Working Paper 470, Institute for Mathematical Economics, Bielefeld University.
- Hojman, D. A., Szeidl, Á., 2006. Endogenous networks, social games and evolution. *Games and Economic Behavior* 55: 112-130.
- Holm, H. J., Opper, S., Nee, V., 2013. Entrepreneurs under uncertainty: An economic experiment in China, *Management Science* 59: 1671–1687.
- Ivanov, A., 2011. Attitudes to ambiguity in one-shot normal-form games: an experimental study. *Games and Economic Behavior* 71: 366-394.
- Jackson, M. O., van den Nouweland, A., 2005. Strongly stable networks. *Games and Economic Behavior* 51: 420-444.
- Jackson, M. O., Watts, A., 2002. The evolution of social and economic networks. *Journal of Economic Theory* 106: 265-295.
- Jackson, M. O., Watts, A., 2002. On the formation of interaction networks in social coordination games. *Games and Economic Behavior* 2002: 265-291.
- Jackson, M. O., Wolinsky, A., 1996. A strategic model of social and economic networks. *Journal of Economic Theory* 71: 44-74.
- Kandori, M., Mailath, G., Rob, R., 1993. Learning, mutation and long run equilibria in games. *Econometrica* 61: 29-56.
- Kelsey, D., Le Roux, S., 2015. An experimental study on the effect of ambiguity in a coordination game. *Theory and Decision* 79: 667-688.
- Kelsey, D., Le Roux, S., 2017. Dragon slaying with ambiguity: theory and experiments. *Journal of Public Economic Theory* 19: 178-197.

- Klette, T.J., Kortum, S., 2004. Innovating firms and aggregate innovation, *Journal of Political Economy* 112:986-1018.
- Kocher, M. G., Lahno, A., Trautmann, S., 2018. Ambiguity aversion is not universal. *European Economic Review* 101: 268-283.
- König M. D., Rogers, T., 2018. Endogenous technology cycles in dynamic R&D Networks, CEPR DP13307.
- König, M. D., Tessone, C. J., Zenou, Y., 2014. Nestedness in networks: A theoretical model and some applications, *Theoretical Economics* 9: 695-752.
- Li, C., Turmunkh, U., Wakker, P., 2019. Trust as a decision under ambiguity. *Experimental Economics* 22: 51-75.
- Luo, C., Mauleon, A., Vannetelbosch, V., 2018. Network formation with myopic and farsighted players. CORE Discussion Papers 2018025, Université Catholique de Louvain, Center for Operations Research and Econometrics (CORE).
- McBride, M., 2006. Imperfect monitoring in communication networks, *Journal of Economic Theory* 126: 97-119.
- Myerson, R., 1991. *Game theory: analysis of conflict*. Harvard University Press, Vambridge MA.
- Persson , L., Seiler, T., 2018. Entrepreneurial optimism and creative destruction, IFN Working Paper No. 1218.
- Peterson, C., 2000. The future of optimism. *American Psychologist* 55: 44-55.
- Pulford, B.D., Colman, A.M., 2007. Ambiguous games: evidence for strategic ambiguity aversion. *Quarterly Journal of Experimental Psychology* 60: 1083-1100.

- Rubinstein, A., Wolinsky, A., 1994. Rationalizable conjectural equilibrium: between Nash and rationalizability, *Games and Economic Behavior* 6: 299-311.
- Schipper, B., 2019. The evolutionary stability of optimism, pessimism, and complete ignorance. Mimeo, UC Davis.
- Schmeidler, D., 1989. Subjective probability and expected utility without additivity. *Econometrica* 57: 571-587.
- Srivastava, S., Angelo, K. M., 2009. Optimism, effects on relationships. In: Reis, H. T., Sprecher, S. K. (eds.), *Encyclopedia of human relationships*. Thousand Oaks, CA: Sage.
- Staudigl, M., 2011. Potential games in volatile environments. *Games and Economic Behavior* 72: 271-287.
- Tiger, L., 1979. *Optimism: the biology of hope*. New York, Simon and Schuster.
- Topkis, D., 1979. Equilibrium points in nonzero-sum n-person submodular games. *SIAM Journal of Control and Optimization* 17: 773-87.
- Van Huyck, J., Battalio, R. C., Beil, R. O., 1990. Tacit coordination games, strategic uncertainty and coordination failures. *American Economic Review* 80: 234-248.
- Watts, A., 2001. A dynamic model of network formation. *Games and Economic Behavior* 34: 331-341.
- Westbrock, B., 2010. Natural concentration in industrial research collaboration, *RAND Journal of Economics* 41: 351-371.
- Young, H. P., 1993. The evolution of conventions. *Econometrica* 61: 57-84.