



HAL
open science

Modular Power Electronics: The missing link in Rural Electrification?

Luiz Fernando Lavado Villa

► **To cite this version:**

Luiz Fernando Lavado Villa. Modular Power Electronics: The missing link in Rural Electrification?. Symposium de Génie Electrique, Université de Lorraine [UL], Jul 2018, Nancy, France. 7p. hal-02983367

HAL Id: hal-02983367

<https://hal.science/hal-02983367v1>

Submitted on 29 Oct 2020

HAL is a multi-disciplinary open access archive for the deposit and dissemination of scientific research documents, whether they are published or not. The documents may come from teaching and research institutions in France or abroad, or from public or private research centers.

L'archive ouverte pluridisciplinaire **HAL**, est destinée au dépôt et à la diffusion de documents scientifiques de niveau recherche, publiés ou non, émanant des établissements d'enseignement et de recherche français ou étrangers, des laboratoires publics ou privés.

Modular Power Electronics: The Missing Link in Rural Electrification?

Luiz Fernando LAVADO VILLA
University of Toulouse - LAAS-CNRS

More than a billion people still lack access to electricity in rural regions throughout the world. Rural electrification is the part of the Development Engineering research field that studies this issue. In theory, rural electrification is achieved through energy tiers, going from low to high. In practice, low tier stand-alone systems are very difficult to upgrade to higher-tiers micro-grids. This constitutes a *missing link* that locks millions in poverty. In this work, modular power electronics are analyzed as the potential solution to this *missing link*. This paper proposes a theoretical framework to analyze modular power converters for multi-tier rural micro-grids expansion. Five different tier scenarios are extracted from the literature and used to analyze two modular power converter topologies. The results are summarized through the "expansion signature" tool which can be used as a basis for future analysis.

Keywords – Rural Electrification, Modular Power Electronics, Converter Design, Energy Access

INTRODUCTION

More than a billion people still lack clean and safe electricity in rural regions throughout the world [1]. Electrification in developing countries has historically been practiced through the expansion of the main grid. This practice targeted urban areas, leaving rural populations aside due to prohibitive costs [2].

In the past decades, international initiatives, projects and programs have been created to promote, install or operate rural small-scale energy systems, powered by renewable energy systems [3]. The international scientific community has also been an important participant in this rural electrification effort [3, 4]. The literature shows contributions ranging from methods for modeling and estimating local renewable energy resources [5], methods to design and deploy off-grid micro-grids [6], and energy management strategies under severe production constraints [4].

Most contributions follow a distinct pattern. Either authors have focused on high-level, abstract and theoretical concepts [3] or research has focused on solving specific problems through modeling and optimization [5]. The former is adapted to the conception of larger micro-grids while the latter is better adapted to create a small stand-alone installation. While important, these approaches are not linked, making stand-alone systems later incompatible to a larger micro-grid integrated operation [12]. This paper claims that this *missing link* between local scale and large scale rural electrification lies in the use of modular power electronics converters. By finding this missing link, local practitioners would be able to interconnect stand-alone systems to build entire micro-grids. To explore its premise, this paper proposes a theoretical framework to evaluate how modular power electronics can be used to build multi-tier rural micro-grids.

This paper is organized in three sections. First, elementary concepts of this work and the proposed theoretical framework are introduced in the *Multi-tier systems and the missing link in Rural Electrification*. The tier scenarios and power converter topologies used to evaluate multi-tier expansion are presented in section *Cross-Analysis Scenarios and Setups*. Finally, the re-

sults of the analysis are described in section *Results and discussion*.

MULTI-TIER SYSTEMS AND THE MISSING LINK IN RURAL ELECTRIFICATION

Rural electrification and modular power electronics are both multi-disciplinary and complex issues that require a clear and thorough presentation. This section, will introduce and explain several concepts on multi-tier rural electrification systems and modular power converters. Based on these concepts, a Conceptual framework is proposed below.

Rural Electrification

Rural electricity access, or rural electrification, is defined in current literature through a multi-tier framework, ranging from tier 0 (hundreds of Watts) to tier 5 (dozens of kilowatts) [7]. In theory, users start by consuming small amounts of energy and with a small power capacity (tier 0) to create a small stream of extra revenue. As this revenue accumulates, users tend to invest in the expansion of their system in terms of power and energy, leading them into a higher tier. This tier-based system expansion is shown in figure 1.

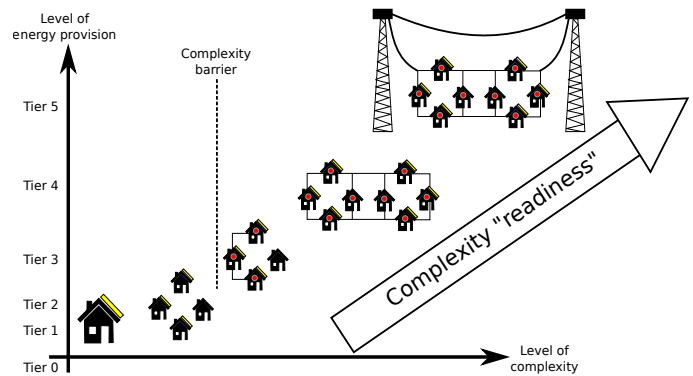

Figure 1. Swarm Electrification Theory [8]

In figure 1, the house icon represents a stand-alone system. At lower tiers, these systems are totally independent. As the system evolves to a higher tier, several independent stand-alone systems are interconnected, represented here by a red dot. At a very high tier the whole micro-grid is connected to the local electric grid. Field feedback confirms that high-tier energy needs are provided by complex and expensive micro-grids while lower-tier needs are provided by stand-alone home systems [8].

The advancement from lower to higher tiers is hampered by issues such as technology incompatibility, cost, aging, and the growing complexity of the system. These factors are represented in figure 1 by the *complexity barrier* and the *complexity readiness*. Complexity readiness imposes challenges in classic system design because it implies an user-driven unplanned expansion, leading to several issues in current rural electrifi-

cation programs [9]. Some authors suggest a theoretical solution through a bottom-up electrification approach called *Swarm Electrification*.

In theory, swarm electrification requires energy management technology to be user-centered, legacy compatible, multi-tier and adaptive [8]. By putting the user in the center of the electrification process, swarm electrification seeks to link the expansion from lower and higher tiers. This assessment has been recently reinforced by IEEE and the World Bank, who stated that a “critical roadblock [to rural electrification] include the need of an ultra-low-cost communication/control-layer and the need to drive growth through market-pull as opposed to the technology-push models ” [10].

In practice, an energy control-layer is provided by power electronics converters. However, the common practice in power electronics is to optimize the converter to a fixed set of specification [11]. While this practice is perfectly adapted to a tier-by-tier electrification approach, it cannot answer to rural electrification needs because not only the conditions for which these converters were specified changes rapidly but also these converters are built as stand-alone units with limited or no capacity to be interconnected to other units and adapt to an unpredictable expansion of the system [12].

In this work, the *missing link* in rural electrification is to create a power electronics converter ultra-low-cost, user-centered, legacy compatible, multi-tier and adaptive, that can answer to the unpredictable nature of rural electrification. And this paper proposes to study the use of modular power electronics as an answer to this issue.

Modular Power Electronics

Modular power electronics are based on the idea that an elementary module can be used as a base to create power converters that can be expanded and adapted to different specifications [11]. Otherwise known as *Power Electronics Building Blocks* (PEBB), this approach to the design of power electronics converters provides the answer to the *missing link* of multi-tier rural electrification.

The design of a PEBB converter is composed of both its overall architecture and its elementary module. There are dozens (if not hundreds) of modular system architectures, each with their advantages and drawbacks [13, 14, 15]. These architectures can clearly be adapted to the changes in tier of the overall system by expanding the number of elementary blocks. There are also dozens of elementary modules, each with its properties [16]. Some elementary cells have current-limiting capabilities and some authors explore how the mix of heterogeneous cells can impact the overall control of the power converter [16].

Despite these promising traits, a Conceptual framework is still needed to evaluate the use of modular power electronics to build multi-tier rural electrification systems.

A Conceptual framework for modular power electronics in rural electrification

The Conceptual framework proposed in this work is based on a series of levels of abstraction linking a power module with a rural micro-grid. These levels of abstraction are shown in figure 2 as *power module*, *power converter*, *rural micro-grid*, and *energy sources, loads and storage elements*.

Power modules implement base topologies to answer to a set of specifications. Base topologies are circuits which connect active power switches and passive components to achieve either a DC/DC or a DC/AC electrical conversion controlled by its close control. Specifications are practical constraints, such as voltage rating, which define the limits of the power module input-output behavior. Close control, in the scope of this project, is a mathematical function implemented in a micro-controller that uses analog measurements of electrical variables within the power module, such as input voltage, to determine the duty cycle of the power module active switches.

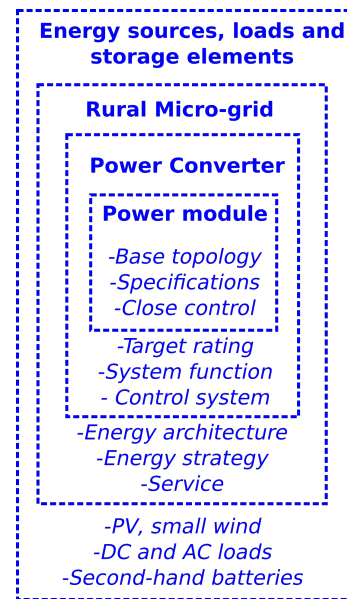

Figure 2. The Conceptual framework proposed in this paper

Power converters associate power modules to reach a target rating and to provide a system function. A target rating is expressed in terms of practical operating conditions of the power converter such as input voltage range or nominal power output. A system function is an input-output behavior of the power converter implemented or not by its control system that provides a specific system-level action. System functions implemented by the control system require some active mathematical calculation to keep the power converter in a dynamic point of operation such as DC voltage regulation. System functions not implemented by the control system are considered passive system functions, such as voltage isolation or current limitation.

Rural micro-grids, in the scope of this project, are electric installations composed of an energy architecture that provides an energy strategy. An energy architecture is the interconnection of power converters to connect energy sources, loads and storage elements. An energy strategy is the control provided by some high-level algorithm which determines the energy flow between *energy sources, loads and storage elements* with the objective of providing services such as uninterrupted energy supply or minimizing the cost of energy.

This work is based on the idea that there exists a *power module* base topology, set of *specifications* and *close control* which allows a *power converter* to reach any *target rating*, ensure all possible *system functions* and create any type of *control system*. In turn, this *power converter* can be used to build a *rural micro-grid* with any type of *energy architecture* which provides any type of *service* by using any type of *energy strategy*. This *cascaded effect* will lead to the creation of a multi-tier micro-grid which can interconnect any type of *energy source, load and storage element*.

The analysis in this work will focus on providing a tool that can be used to compare different *power modules* within this *cascaded effect* framework through the cross-analysis scenarios and setups below.

CROSS-ANALYSIS SCENARIOS AND SETUPS

To compare how different *power modules* are instrumental to the creation of a multi-tier *rural micro-grid*, this work defines a set of tier scenarios and power modules. These are then used cross-analyze through a tier-by-tier incremental method described below.

Tier scenarios

There are many different case studies in the rural electrification literature, ranging from stand-alone home systems [9] to megawatt-sized micro grids [12]. To summarize these cases into a comprehensive multi-tier scenario, this work proposes the following tier-based analysis.

Table 1. Tier scenarios available in the literature and their description

Tier	Description	Ref.
0	Small power applications and stand alone systems	[1]
1	Small stationary systems for charging cell phones	[9]
2	Small stationary system with two sources for medium loads	[8]
3	Medium sized system with more than one AC load and bus	[15]
4	Medium sized system with multiple users	[1]
5	Interconnection of a community	[12]

The literature does not provide an explicit link between these scenarios in terms of rural off-grid expansion. In this paper, the analysis is based on the premise that these scenarios are linked and that a hypothetical micro-grid expands from one tier to another sequentially. Each tier scenarios is detailed through the Conceptual framework described in figure 2, giving table 2.

Each tier scenario will be represented by a circuit, going from figure 3 for the tier 0 scenario to figure 8 for the tier 5 scenario.

The tier 0 scenario considers a single power converter that connects a small PV module with a small battery and DC load, as shown in figure 3.

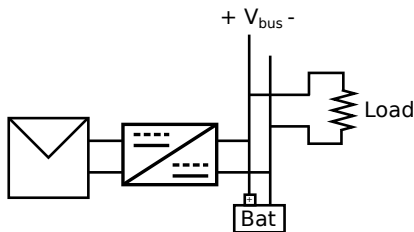

Figure 3. Tier 0 study case

The tier 1 scenario considers that battery capacity rises and that the load requires a specific voltage or current control, giving figure 4.

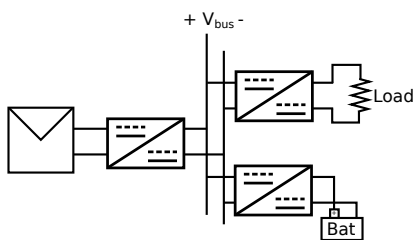

Figure 4. Tier 1 study case

The tier 2 scenario represents two neighbors whose DC buses are connected together. Each household is considered to have its own energy production and load profile, with a small wind turbine being connected straight to the DC bus through a diode bridge, as shown in figure 5.

The tier 3 scenario considers that four neighbors are connected together, one of which has an AC bus, shown in figure 6.

The tier 4 scenario considers that a fifth neighbor is connected to the group. This new member has a non-balanced three-phase

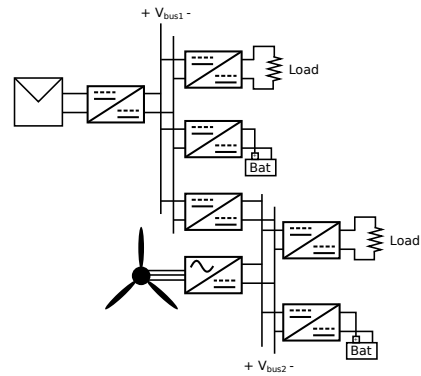

Figure 5. Tier 2 study case

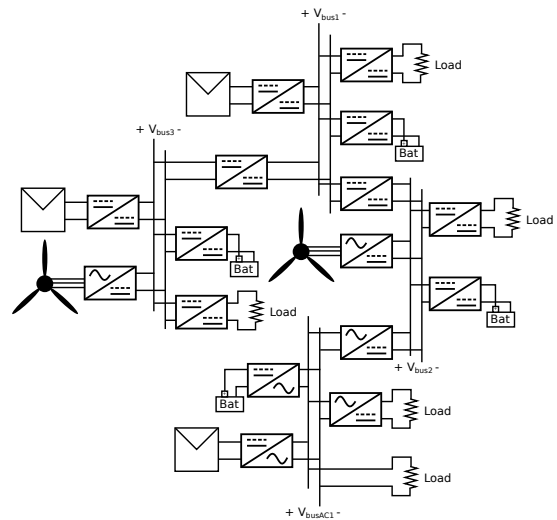

Figure 6. Tier 3 study case

system powered by a small diesel generator and a small hydro plant, as shown in figure 7.

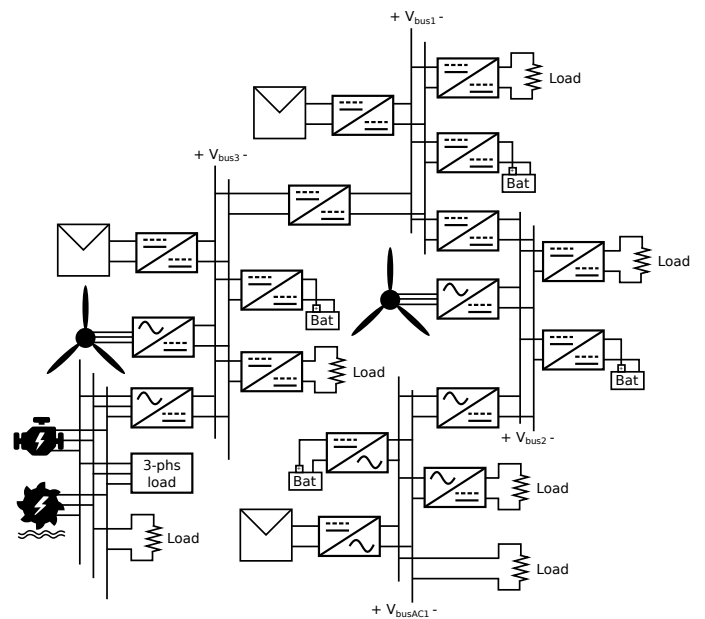

Figure 7. Tier 4 study case

Finally, the last tier considers a far away sixth neighbor which also has a 3 phase system powered by a diesel generator and

Table 2. Multi-tier scenarios from the literature evaluated through the Conceptual framework proposed in this work

Tier		Energy source, load and storage			Rural micro-grid		Power converter	
Lvl.	Power	Energy source	Load	Storage element	Energy Architecture	Energy Strategy	System function	Target rating
0	100W	PV	DC	Small Battery	Single DC Bus	All energy to load	V & I control	$12V_{DC}$ to $24V_{DC}$
1	500W	PV	DC	Battery Bank	Single DC Bus	Energy to load and battery	DC current limitation & Bi-directional DC current	$24V_{DC}$ to $48V_{DC}$
2	2kW	PV & Small Wind	DC	Multiple Battery Banks	Multiple DC Buses	Energy between battery banks	Interleaving	$48V_{DC}$ to $96V_{DC}$
3	5kW	PV & Small Wind	DC & AC	Multiple Battery Banks	DC & AC Buses	AC voltage regulation	Single-phase DC-AC inversion	$400V_{DC}$ & $230V_{AC}$
4	15kW	Multiple sources	DC & AC	Multiple Storage	DC & AC Buses	Local Energy flow optimization	Three-phase DC-AC inversion	$400V_{DC}$ & $230V_{AC}$
5	30kW	Multiple sources	DC & AC	Multiple Storage	Multiple Voltage Buses	Global Energy flow optimization	PQ control & AC-DC rectification	$1000V_{DC}$

a small hydro plant. Due to the distance, this last neighbor is connected through an AC-AC converter, possibly with a DC link in the middle, as shown in figure 8.

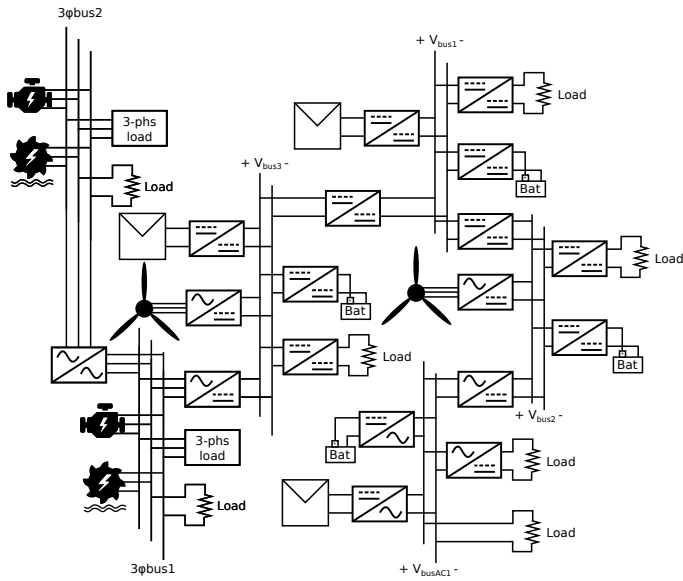

Figure 8. Tier 5 study case

The next step in the study is to define the *power modules* that will be cross-analyzed using these tier scenarios.

Base power electronics modules setups

Modular power electronics span a vast range of applications and topologies [16]. In this work, the most elementary *power module* is considered to be the one that can reproduce the greatest number of *power converters* and *energy architectures* available in the literature [13, 16]. Considering the expansion potential of a *rural micro-grid* from a low-voltage DC to a higher voltage three-phase AC system, the elementary *power modules* should be able to provide both DC to DC and DC to AC functions.

Two elementary power modules were considered in this analysis: a synchronous buck and a power-factor corrector, as shown in table 3.

The Synchronous Buck (SB) is the most elementary power module, capable of being combined to create almost all the topologies available in the literature. However, this flexibility comes with the price of synchronizing many *power modules* in series or in parallel.

The Power Factor Corrector (PFC) encapsulates the equivalent of three SBs into one single *power module*. In this work, each SB leg is considered to be independent, thus allowing a single PFC *power module* to process up to three different power flows in parallel. This redundancy comes with the price of handling the synchronization of the different legs within the same *power module*.

Both SB and PFC *power modules* are considered to be rated to operate at $400V_{DC}$ or $230V_{AC}$.

Table 3. Power Modules used in this study

Module	Description	Ref.
SB	DC-DC, current-bidirectional, parallel operation	[17]
PFC	DC-DC, DC-AC, Single and Three-phase	[18]

The topologies of the SB and PFC converters are given in figures 9 and 10, respectively.

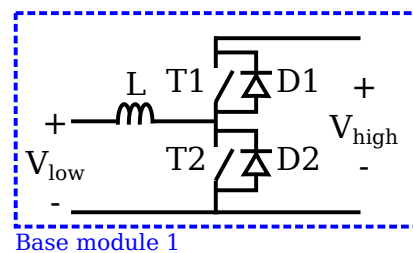
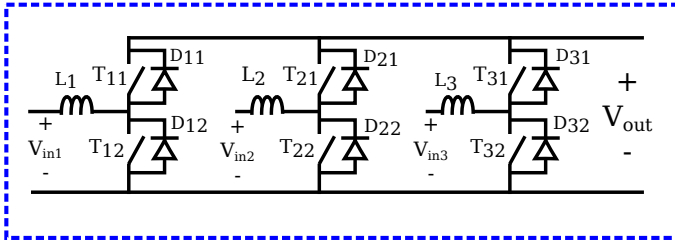

Figure 9. Base Module 1: Synchronous Buck Converter



Base module 2

Figure 10. Base Module 2: Power Factor Corrector Converter

With both the tier scenarios and base module topologies, the study can now focus on the analysis method used to cross-analyze them.

Analysis method

The analysis method proposed in this work seeks to determine how the complexity of a *rural micro-grid* would evolve if this *rural micro-grid* were built using a single type of *power module*. The objective is to determine an "expansion signature", which shows how complexity evolves as the system changes tiers. To estimate the system "complexity" this work will use four figures-of-merit related to hardware and software issues as summarized in table 4.

Table 4. Figures-of-merit used to estimate "complexity" in this work

Type	Indicator	Description
Hardware	Number of modules	Indirect measure of hardware complexity
	Target ratings	Shows how higher power flow drives complexity
Software	Number of functions	Indirect measure of the firmware complexity
	Synchronization	Shows how more complex functions drive complexity

The *hardware figures-of-merit* used in this work are *number of modules* and *converter target rating*. The *number of modules* gives an indirect reference to how hardware complexity grows within the system, and the evolution of *target ratings* shows how converters become more complex as the *rural micro-grid* manages a greater power flow.

The *software complexity figures-of-merit* are the *number of functions* and the *synchronization techniques*. The *number of functions* gives a measure of the complexity of the firmware needed to ensure the correct operation of the *rural micro-grid*, and the evolution of *synchronization techniques* describes the complexity of coordinating blocks of code embedded in different microcontrollers to provide all the functions needed by the *rural micro-grid*.

The complexity indicator is calculated from a geometric average of these four figures-of-merit. A geometric average is used due to the different scales of each figure-of-merit, forcing a mathematical normalization of any changes.

$$Cmpx_{IND} = \sqrt[4]{\#Mod \cdot Rat \cdot \#func \cdot Sync} \quad (1)$$

Where $\#Mod$ represents the number of modules, Rat represents the target ratings, $\#func$ describes the number of functions and $Sync$ is the synchronization issues.

Based on equation 1, a *rural micro-grid* can be analyzed in terms of the evolution of its energy provision and complexity. This analysis is based on the energy/complexity diagram shown in figure 11.

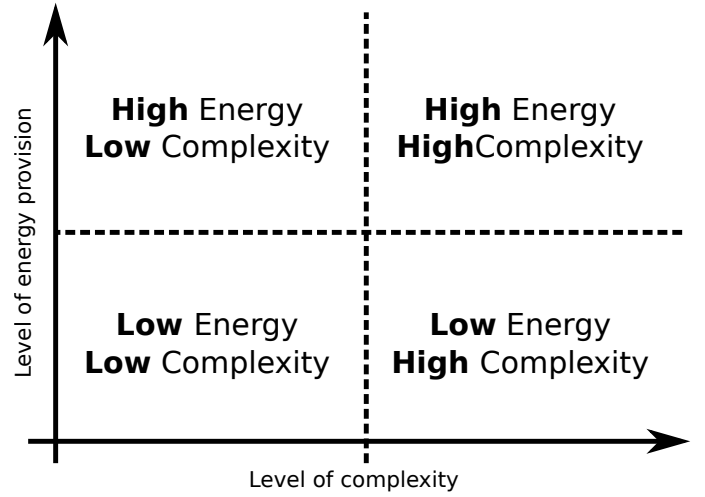

Figure 11. Energy versus Complexity diagram

Four quadrants are shown in figure 11, according to the level of energy provision and complexity. On the bottom left are low energy and low complexity systems, typical of low tier applications such as solar home systems and stand alone PV plants. On the bottom right are low energy and high complexity systems, this is typical of solutions that are too complex for little energy gain. On the upper left are high energy and low complexity systems, these are high energy gain systems with little complexity such as the isolated AC grids built from diesel generators. Finally, on the upper right are high energy and high complexity systems, these cases are based on renewable energy systems with power converters, batteries and multiple sources.

The "expansion signature" of a *rural micro-grid* shows through which of these quadrants the *rural micro-grid* goes through as it change tiers. A *rural micro-grid* should avoid the bottom right quadrant and, ideally, go from low-energy/low-complexity to high-energy/low-complexity.

The "expansion signature" of a SB-based or PFC-based *rural micro-grid* can now be estimated.

RESULTS AND DISCUSSION

Based on the methodology proposed above, a SB-based and a PFC-based *rural micro-grids* expanding from tier 0 to tier 5 were evaluated in terms of hardware and software figures-of-merit.

In tier 0, the hardware is at its least complex state. The number of boards is one for both SB and PFC, target ratings are met without any special series or parallel connection, and both boards have the same function. PFC has a higher score only in terms of synchronization since its firmware has to implement some sort of routine to handle the fact it only uses a single leg.

In tier 1, an SB-based *rural micro-grid* requires 3 boards while a PFC-based solution can still use a single board. The target ratings are still met without series or parallel connections. The number of functions now has risen due to MPPT, bi-directional current flow and DC current limitation. In terms of synchronization, the SBs are totally autonomous and do not require any coordination. However, the PFC has to handle source, load and storage, leading to a more complex synchronization among its legs.

In tier 2, the number of SB boards rises to 7, one for each converter and two for the DC bus interconnection. PCF achieves the same functions with only 3 boards. In terms of ratings, two SB boards are put in parallel to manage the current flow between the DC buses, giving it a higher score. The number of functions has now risen to 5 since interleaving is needed to flow large amounts of current between the two DC buses. Synchronization scores higher for SB since two boards must be synchronized for

interleaving, this also rises the PFC synchronization score.

In tier 3, an AC bus is included in the rural micro-grid. To provide all the new AC loads, AC sources and the AC bus, the SB-based micro-grid requires 20 boards, 8 to create the 4 single-phase inverters, 2 to interconnect the new DC bus and 3 for the new DC system. The PFC-based micro-grid requires only 9 boards. Target ratings remain the same, since only parallel connections are needed in this tier. The number of functions now rise to 6 to include DC to AC inversion. Synchronization scores higher to include DC-AC inversion that requires a new synchronization strategy among different legs for both SB and PFC.

In tier 4, a three-phase AC bus is included in the rural micro-grid. To interconnect the new AC bus with one of the DC buses, the SB-based rural micro-grid requires 6 boards, two boards in series per phase. The PFC requires only 3 boards for the same reason. This series-connection rises the target rating score for both SB and PFC. The number of functions now rises to 8 to include 3 phase inversion and PQ control. The synchronization score for both SB and PFC rises to account for the new technique needed to synchronize series-connected non-isolated converters.

Finally, in tier 5, two three-phase AC buses are interconnected through an AC-AC converter. This converter is implemented through the connection of two AC-DC converters back-to-back. The SB-based solution requires 4 boards per phase, while the PFC requires only 4 boards in total. The target ratings for both SB and PFC rise due to this higher series connection. The number of functions now rises to 9 to include active rectification. Synchronization rises to account for the issues of synchronizing 4 boards in series.

The results are summarized in tables 5 and 6.

Table 5. Synchronous Buck (SB) tier evolution

F.O.M.	T0	T1	T2	T3	T4	T5
# boards	1	3	7	20	26	38
target ratings	1	1	2	2	3	4
# functions	1	4	5	6	8	9
synchronization	1	1	2	3	5	6

Table 6. Power Factor Corrector (PFC) tier evolution

F.O.M.	T0	T1	T2	T3	T4	T5
# boards	1	1	3	9	11	15
target ratings	1	1	1	1	2	3
# functions	1	4	5	6	8	9
synchronization	2	3	4	5	6	7

Using the score given above and equation 1, the "expansion signature" for both SB and PFC can be calculated for each tier. Figure 12 shows the result using the analysis diagram proposed in figure 11. The results in the x axis are normalized for the highest complexity indicator score. It should be noted that the x axis scale is not linear, meaning a complexity of 1 is not necessarily twice more complex than 0.5. This scale should be read relative to both "expansion signatures", where a signature with lower complexity describes a less complex system.

Several conclusion can be drawn from the results in figure 12.

Both SB and PFC based *rural micro-grids* expand with similar complexity ratings for lower tiers. This means that complexity alone is not enough to determine which solution is best for lower tiers, other aspects such as cost should also be analyzed.

Using SB *base modules* ultimately leads to more complex *rural micro-grids* for higher tiers. This is specially driven by the

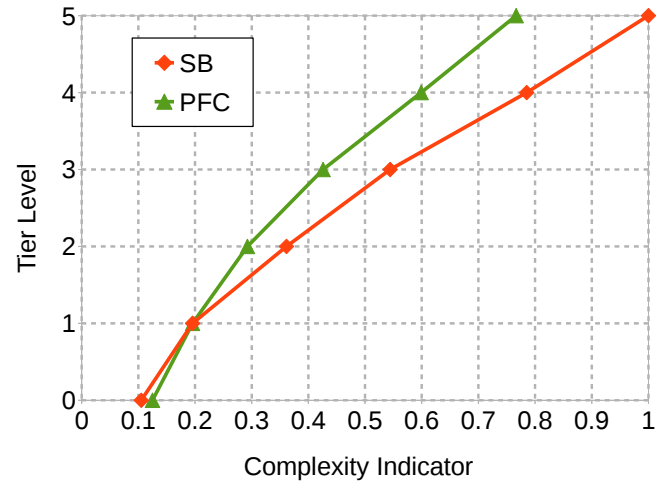

Figure 12. Complexity signature for each base power module

fact that SB-based systems require many boards for AC operation.

The expansion signatures are given for a homogeneous *rural micro-grid* built using a single *base module*. It can be inferred that a heterogeneous rural micro-grid, built using two or more *base modules*, should be capable of achieving the best "expansion signature" by using different *base modules* when expanding at certain specific tiers.

In terms of quadrant evolution, the results indicate that the "expansion signature" of PFC passes closer to the high-energy/low-complexity quadrant than the SB. It is important to note that quadrant evolution is relative to the solutions being compared and their signatures, requiring more than one solution to be analyzed.

It is important to insist that these result are totally conditioned to the tier scenarios taken into account and the figures-of-merit chosen for the analysis. Further studies should diversify scenarios and take into account other indicators to create a more thorough "expansion signatures".

Finally, coming back to the original question of this article, figure 12 shows that the PFC converter is closer to providing a missing link than the SB converter by comparing their "expansion signature". While further research is needed to cross-compare non-modular with modular solutions, it is clear that the theoretical missing link converter has a vertical "expansion signature" going from the low-energy/low-complexity straight into the high-energy/low-complexity quadrant. Future work should build on this idea to provide more solid evidence of which base module modular power electronics as a missing link in rural electrification.

CONCLUSIONS

Rural electrification is a challenging field that studies the provision of electricity to rural households around the world. Rural electricity access is provided through energy tiers, going from low tiers (100W) to high tiers (dozens of kW), but the expansion from a low to a high tier is blocked by growing complexity, equipment incompatibility and cost. A power converter that can adapt to the unpredictable complex nature of rural electrification is considered to be the *missing link* between low and high tiers.

This work studies the use of modular power electronics converters to address this *missing link* idea. To do so, a Conceptual framework is introduced to link modular power electronics concepts and rural electrification issues. Based on this Conceptual framework, six tier scenarios, ranging from tier 0 to tier 5, are described in detail. Along with these scenarios, two base mod-

ules, the synchronous buck and the power factor corrector, are introduced.

A cross analysis of these tier scenarios and base modules using four figures-of-merit, two related to hardware and two related to software issues, was also proposed. A complexity indicator is calculated based on the scores of these figures-of-merit. When plotted against its equivalent tier-level, this indicator provides an "expansion signature" of the rural micro-grid.

The comparison of the expansion signatures of the synchronous buck and power factor corrector base modules shows that the latter can be considered closer from being a *missing link* converter than. However, further work is still needed to conclude if other topologies can perform even better in the same analysis.

The "expansion signature" tool proposed in this work can be used as a basis to study the evolution of the complexity of a micro-grid as it expands. This tool can be used for future studies such as the comparison of using a single base module or of using several base modules to expand the same micro-grid or a comparison between renewable energy based micro-grid expansion and fossil-fuel based micro-grid expansions. Finally, this tool can be greatly improved by incorporating more figures-of-merits or using other formulas to calculate the complexity indicator.

REFERENCES

- [1] IEA. World Energy Outlook 2012. Paris CEDEX: OECD Publishing 2012
- [2] Stefano Mandelli, Jacopo Barbieri, Riccardo Mereu, Emanuela Colombo, Off-grid systems for rural electrification in developing countries: Definitions, classification and a comprehensive literature review, Renewable and Sustainable Energy Reviews, Volume 58, May 2016, Pages 1621-1646
- [3] R.K. Akikur, R. Saidur, H.W. Ping, K.R. Ullah, Comparative study of stand-alone and hybrid solar energy systems suitable for off-grid rural electrification: A review, Renewable and Sustainable Energy Reviews, Volume 27, November 2013, Pages 738-752, ISSN 1364-0321,
- [4] Lanre Olatomiwa, Saad Mekhilef, M.S. Ismail, M. Moghavvemi, Energy management strategies in hybrid renewable energy systems: A review, Renewable and Sustainable Energy Reviews, Volume 62, September 2016, Pages 821-835, ISSN 1364-0321
- [5] Prabodh Bajpai, Vaishalee Dash, Hybrid renewable energy systems for power generation in stand-alone applications: A review, Renewable and Sustainable Energy Reviews, Volume 16, Issue 5, June 2012, Pages 2926-2939
- [6] Diana Neves, Carlos A. Silva, Stephen Connors, Design and implementation of hybrid renewable energy systems on micro-communities: A review on case studies, Renewable and Sustainable Energy Reviews, Volume 31, March 2014, Pages 935-946
- [7] Bhatia et al. "Capturing the multi-dimensionality of energy access.", World Bank, 2014
- [8] Groh et al. "A system complexity approach to swarm electrification." UCL STEaPP, 2015
- [9] Schnitzer et al. "Microgrids for rural electrification." United Nations Foundation, 2014
- [10] Divan et al. , "IEEE Power Electronics Society "Light Up a Billion Smiles" Workshop [Society News]," in IEEE Power Electronics Magazine, vol. 4, no. 3, pp. 64-67, 2017
- [11] Ginn et al."Control Architecture for High Power Electronics Converters," in Proceedings of the IEEE, vol. 103, no. 12, pp. 2312-2319, 2015
- [12] Tenenbaum et al. From the bottom up : how small power producers and mini-grids can deliver electrification and renewable energy in Africa. Washington, 2014
- [13] Babaei et al. "An overview of different topologies of multi-port dc/dc converters for dc renewable energy source applications," 13th International Conference on Electrical Engineering/Electronics, Computer, Telecommunications, 2016
- [14] Lavanya et al. "Multi-input DC-DC converter topologies-a review," 2016 International Conference on Electrical, Electronics, and Optimization Techniques (ICEEOT), pp. 2230-2233, 2016
- [15] Scholten et al. "Micro-inverters in small scale PV systems: A review and future directions," 2013 Australasian Universities Power Engineering Conference (AUPEC), 2013, pp. 1-6
- [16] Nami et al. "Modular Multilevel Converters for HVDC Applications: Review on Converter Cells and Functionalities," in IEEE Transactions on Power Electronics, vol. 30, no. 1, pp. 18-36, 2015
- [17] E. Vidal-Idiarte, A. Marcos-Pastor, R. Giral, J. Calvente and L. Martinez-Salamero, "Direct digital design of a sliding mode-based control of a PWM synchronous buck converter," in IET Power Electronics, vol. 10, no. 13, pp. 1714-1720, 10 27 2017
- [18] F. A. Moreno, J. D. Paucara, C. G. Prez, J. J. Sotomayor and D. E. Sal y Rosas, "A grid-tied power factor corrector microinverter without electrolytic capacitor by the control of voltage in a DC-link for a non-linear load," 2017 14th International Conference on Electrical Engineering, Computing Science and Automatic Control (CCE), Mexico City, 2017, pp. 1-6