



HAL
open science

Review of composite sandwich structure in aeronautic applications

Bruno Castanié, Christophe Bouvet, Malo Ginot

► **To cite this version:**

Bruno Castanié, Christophe Bouvet, Malo Ginot. Review of composite sandwich structure in aeronautic applications. Composites Part C: Open Access, 2020, 1, pp.0. 10.1016/j.jcomc.2020.100004 . hal-02952087

HAL Id: hal-02952087

<https://hal.science/hal-02952087>

Submitted on 29 Sep 2020

HAL is a multi-disciplinary open access archive for the deposit and dissemination of scientific research documents, whether they are published or not. The documents may come from teaching and research institutions in France or abroad, or from public or private research centers.

L'archive ouverte pluridisciplinaire **HAL**, est destinée au dépôt et à la diffusion de documents scientifiques de niveau recherche, publiés ou non, émanant des établissements d'enseignement et de recherche français ou étrangers, des laboratoires publics ou privés.



Open Archive Toulouse Archive Ouverte (OATAO)

OATAO is an open access repository that collects the work of some Toulouse researchers and makes it freely available over the web where possible.

This is an author's version published in: <https://oatao.univ-toulouse.fr/26733>

Official URL : <https://doi.org/10.1016/j.jcomc.2020.100004>

To cite this version :

Castanié, Bruno and Bouvet, Christophe and Ginot, Malo Review of composite sandwich structure in aeronautic applications. (2020) Composites Part C: Open Access, 1. ISSN 2666-6820

Any correspondence concerning this service should be sent to the repository administrator:

tech-oatao@listes-diff.inp-toulouse.fr

Review of composite sandwich structure in aeronautic applications

Bruno CASTANIE^{a,*}, Christophe BOUVET^a, Malo Ginot^{a,b}

^a Institut Clément Ader (ICA), Université de Toulouse, CNRS UMR 5312, INSA, ISAE Supaéro, IMT Mines Albi, UPS, Toulouse, France

^b Elixir Aircraft, Batiment D1 - 6 rue Aristide Bergès, 17180 Périgny, France

A B S T R A C T

Keywords:

Composite

Sandwich structures

Aeronautic

This paper presents a review of the issues concerning sandwich structures for aeronautical applications. The main questions raised by designers are first recalled and the complexity of sandwich structure design for aeronautics is highlighted. Then a review of applications is presented, starting with early examples from the 1930s and the Second World War. The growth in the use of sandwich materials in civil and military applications is then developed. Recent research and innovations conclude the paper.

1. Fundamentals of sandwich structures for aircraft applications

1.1. Definition, symmetric and asymmetric sandwiches

“The characteristic feature of the sandwich construction is the use of a multilayer skin consisting of one or more high-strength outer layers (faces) and one or more low-density inner layers (core)”. This definition, proposed by Hoff and Mautner in one of the first articles devoted to sandwich construction, in 1944 [1], remains current and has been taken up in various forms in the works devoted to this type of structure [2–7]. Great numbers of combinations of materials and architectures are possible today, both for the core and for the skins [8]. However, for aeronautical applications, certification greatly restricts the possibilities. Today, only honeycomb cores made of Nomex, aluminium alloy or a limited number of technical foams of very good quality are used. Similarly, for skins, we mainly find aluminium alloys and laminates based on glass, carbon or Kevlar fibres. According to Guedra-Degeorges [9], and also in the case of some stacking described in [10] (see also Fig. 22), for aeronautical applications, the skins have a thickness of less than 2 mm. Sandwiches fall into two categories. Symmetrical sandwiches, such as the one illustrated in Fig. 1, are used mainly for their resistance to buckling and their bending stiffness. This type of sandwich is perfectly suited to pressurized structures or those subjected to an aerodynamic load and, generally speaking, it is by far the most widely used.

Another, somewhat less popular, type of sandwich is also used in aircraft construction: the asymmetrical sandwich (see Fig. 2). As for the classic fuselages composed of a thin skin stabilized by stiffeners, an asymmetrical sandwich is made up of a first skin in carbon laminate called the “*Working Skin*”, which takes most of the membrane stresses from the structure. The buckling resistance of this skin is provided by a

core and a second skin designed at the minimum allowed and consisting of one or two plies of carbon or Kevlar, called the “*Stabilizing Skin*”.

In addition to its particularly high mechanical characteristics, this solution has the advantage of its junction zones being situated in pure laminate areas, thus circumventing the delicate problem of the passage of localized forces to the two skins by inserts. On the other hand, its use is limited to non-pressurized and moderately loaded structures of the helicopter, light aircraft or drone type. Another fundamental difference is the geometric non-linear behaviour due to the offset of the neutral line (in beam theory) with respect to the loading line located in the middle of the working skin. This offset induces a bending moment that is all the greater when the deflection is high. Therefore, a force / displacement coupling occurs, which generates a typical geometric non-linear response and requires an adapted approach [11–14]. According to the experience of the authors, this type of structure is optimal from the mass point of view for non-pressurized structures subjected to low loads. It has been applied in military and civil helicopters [16] and drones, and has been studied for the Solar Impulse planes [17].

1.2. Basic mechanics and sizing issues

Linear static behaviour

The idea behind sandwich construction is to increase the flexion inertia without increasing the mass too much, as shown by D. Gay [7] in a simple numerical application of 3-point bending on a stainless steel beam and then using the same beam with a 20 mm thick honeycomb sandwich core (see Fig. 3). The mass added is very low (20 %), while the deflection under bending is divided by 22 (Eq 2 of Fig. 3). It would have been divided by 90 (δ_{skins}) if the displacement due to transverse shear had not become preponderant because of the weakness of the modulus of the core ($G_{core} = 46$ MPa). Here, we are touching on the subtlety of sandwich structures, where the expected benefits are offset by the com-

* Corresponding author.

E-mail address: bruno.castanie@insa-toulouse.fr (B. CASTANIE).

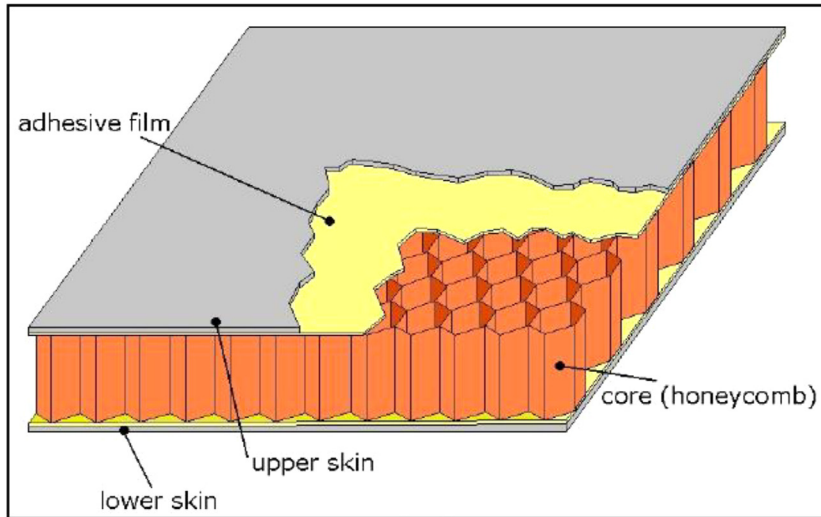

Fig. 1. Sandwich construction.

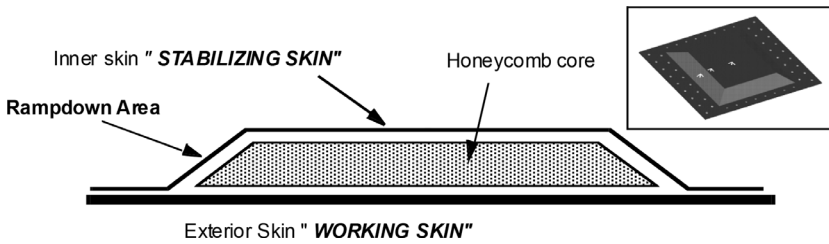

Fig. 2. Asymmetric sandwich structures.

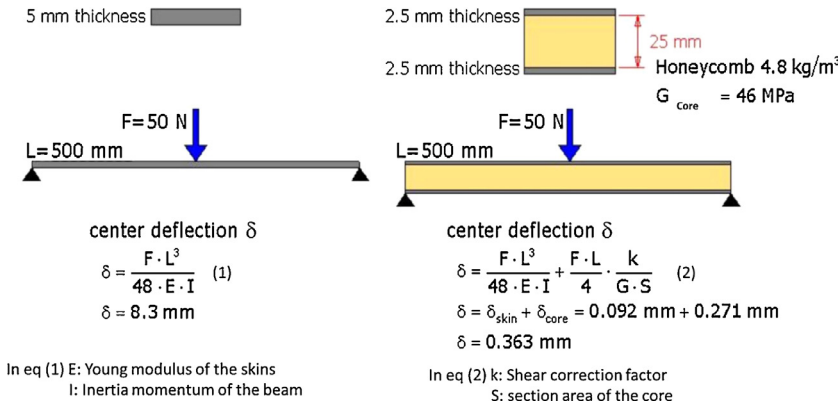

Fig. 3. Bending calculation of a sandwich beam.

plexities generated by a light core. All cases of linear calculations under simple static stresses have been widely developed in the literature [2-7], enabling sizing of the skins and the core.

The core requires special attention because the allowables are very low, of the order of one MPa, whereas the skins generally support loads of several hundred MPa. Therefore, the relative order of magnitude of the stresses in the core is 1% or less. This phenomenon is particularly sensitive in the case of curved sandwiches, e.g. for the tail booms of helicopters or in curved fuselages [18-20], and also for tapered areas.

Global and local buckling

As a first approximation, the increase in the bending stiffness [EI] promises a proportional increase in the critical load for buckling if we refer to Euler's formula: $F_{c \text{ Euler}} = \pi^2 EI / L^2$ for a simply supported beam (L is the length of the beam). But, here again, the influence of the core has to be taken into account and the formula becomes $F_{c \text{ Sandwich}} = F_{c \text{ Euler}} / (1 + F_{c \text{ Euler}} / t_c \cdot G_c)$, where G_c is the transverse shear modulus of the

core and t_c is the thickness of the core. This significantly reduces buckling resistance as shown by Kassapoglou [5]. In addition, the presence of a light core also generates local buckling modes of the skin (wrinkling) or global buckling modes controlled by the core (shear crimping). These modes are often critical and can be the cause of premature failure if they are not given proper consideration. They must imperatively be the object of in-depth investigation even if this involves 3D finite element modelling. For pre-sizing [4-6], a formula (Eq. 1) resulting from a rudimentary analytical theory with restrictive assumptions developed by Hoff and Mautner in 1945 [21] is used for the case of wrinkling. Although this formula gives the trends correctly, the results it provides can prove to be very far from those of experimental tests and a safety factor is required. Zenkerts [4] proposes replacing 0.91 by 0.5 according to his experience in the naval industry. Kassapoglou [5] discusses the relevance of this formula vs finite element modelling in the case of composite skins and tests, and also proposes knockdown factors. In aero-

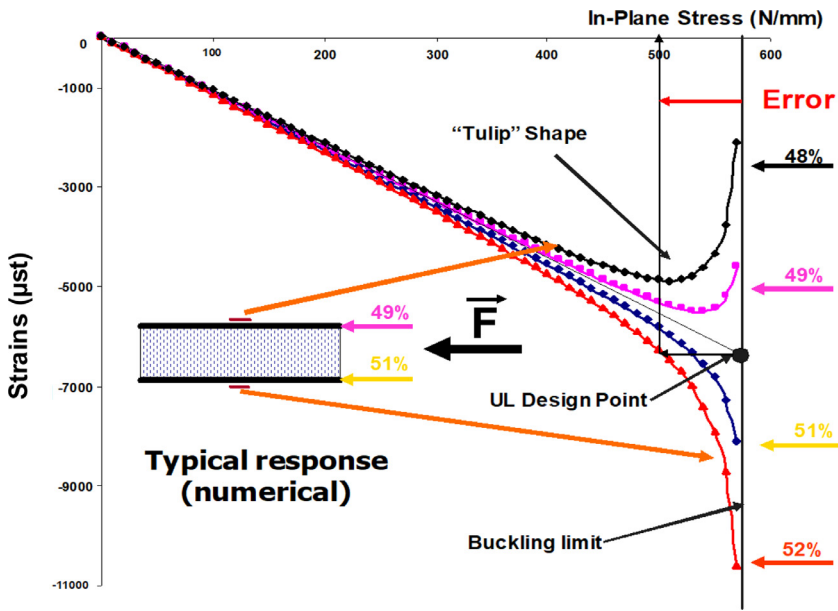

Fig. 4. Non-linear in-plane compression response of symmetric sandwich structures.

navitics, it is common to take a safety factor of 3 to allow for the intrinsic limitations of the formula and the effect of initial shape imperfections [22].

$$\sigma_{critical} = 0.91 \sqrt[3]{E_{Skin} \cdot E_{Core} \cdot G_{Core}} \quad (1)$$

Even though its age, its simplicity and its relative relevance cause this formula to remain the most used, many other approaches have been developed recently [23–30], for example) and would deserve more experimental and numerical evaluation. Moreover, the sizing of aeronautical structures currently uses a GFEM (Global Finite Element Model) that does not capture local buckling. Therefore strategies of global / local calculations [31] or approaches using analytical criteria remain to be defined. Note also that certain environmental effects, such as temperature, can significantly reduce the critical stress of local buckling in the case of a sandwich with a foam core [32], which can be critical for the strength of light structures such as gliders or private planes.

Non linear static behaviour

In general, nonlinear calculation of sandwiches is not necessary because they are subject to bending and their high stiffness means that the structure remains under the assumption of small displacements and strains. However, for aeronautical structures, in particular those that are not pressurized, membrane loads are dominant. This is particularly the case for asymmetrical sandwich structures loaded by the working skin, which naturally have this behaviour [11–15]. For example, when the working skin is loaded in compression, the stabilizing skin may break in tension. On the other hand, it is less known that even symmetrical sandwich structures can exhibit non-linear behaviour in compression, which can strongly influence the design [13,33,34]. This case is shown in Fig. 4, where the software developed in [11–13] was used to compute the compression response of an asymmetrically loaded sandwich beam with a distribution of the force in the skins having the ratios 49-51% or 48-52%. The strains were taken at the centre of each of the two skins and typical tulip-shaped curves were found. These curves are also obtained under compression tests on beams or sandwich plates. This phenomenon had been identified very early by Hoff and Mautner [1], who attributed the nonlinear response in the tests to the loading of the skins not being strictly identical. This seems to be confirmed by the present computation. Hoff and Mautner performed a check of dissymmetry of the strains in the skins up to 5 times before carrying out a test to failure. For this reason, grinding of the faces of the test pieces is recommended before performing this type of test. Some authors have attributed this nonlinear response to an imperfect initial shape [35] which may also have con-

tributed to the phenomenon. In practice, there are several other possible causes, such as variations in manufacturing due to small stacking errors, or differences in fibre volume and/or surface finish due to the manufacturing method. It is also possible that differences in loading between the skins will appear if a tapered area is used.

The tulip curves are bounded by the critical force of the structure. It is classical to use linear assumptions to size the sandwich at the UL design point (UL: Ultimate load). In Fig. 4, this point can be found at the intersection between the linear response, in black, and the critical force (vertical line). Sizing is generally done with a damage tolerance policy (see next subsection) in such a way that, at this point, the strain does not exceed an allowable value (for example, about 6000 µstrain here). However, with a nonlinear calculation as proposed, it can be shown that this value may be reached much earlier, at around 500 N/mm, well before the critical load. Therefore a design that did not take this behaviour into account would be wrong. This phenomenon is, however, less noticeable for plates than for beams and naturally decreases with the bending stiffness of the sandwich [33].

1.3. Damage tolerance

Low speed / low energy impacts, due to handling operations during manufacturing or to dropped tools during maintenance operations, are generally considered. Aeronautical sandwich structures according to the Guedra-Degeorges definition [9] are very sensitive to impact, as are laminated structures. The impact generates a variety of damage in the core and the skins, and the residual strength can be greatly reduced. So a damage tolerance policy must be followed (see Fig. 5 and [10]), which depends on the aircraft type (FAR or EASA from 23 to 29). Given the security challenges, it must be pragmatic and conservative. The method was initially developed for the first certified primary structure: the ATR 72 composite wing box [36] and is now widely used [10,37]. The idea is to distinguish undetectable damage from detectable damage. For the former, the structure must be tolerant to damage from the pristine state and is therefore certified to ultimate loads (UL). For the second, the damage must be repaired, but a distinction is made between damage that requires a thorough inspection to be detected (loads of the design structure with damage: Limit Load) and those immediately detectable (often 0.85 LL). The detectability threshold, called BVID (Barely Visible Impact Damage), is determined by benchmarks with precise inspection times. For a detailed inspection, Airbus has set it at 0.3 mm and, for a quick inspection, at 1.3 mm [38].

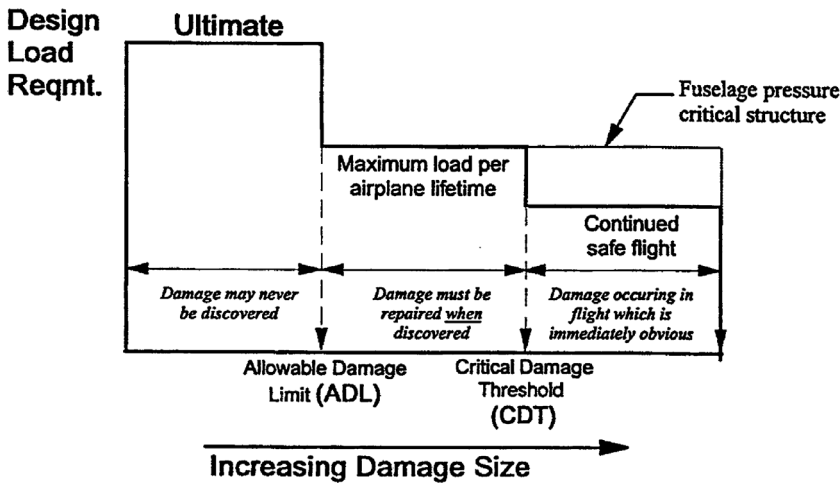

Fig. 5. Damage tolerance policy (reproduced from [10]).

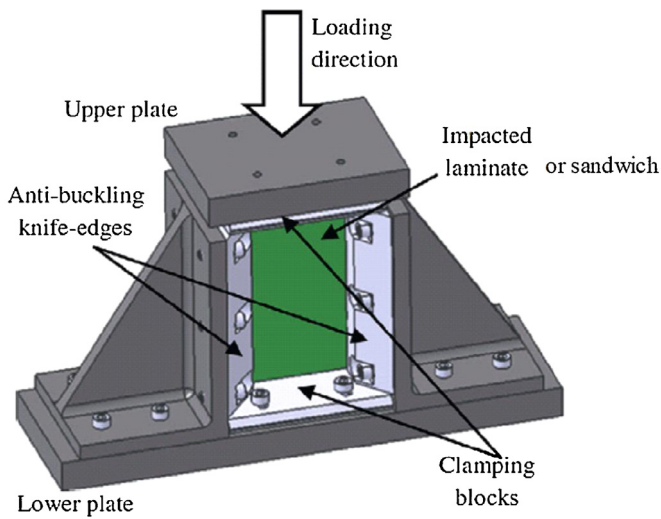

Fig. 6. Compression After Impact apparatus with anti-buckling knives.

The allowables corresponding to the various cases are obtained in Compression After Impact (CAI). The determination is above all experimental in order to satisfy the requirements of the certification and determine the values A or B. A test setup as shown in Fig. 6 is used with a specimen of dimensions $100 \times 150 \text{ mm}^2$. The specimen is impacted in its centre according to internal Airbus or Boeing standards or also ASTM. The allowable then corresponds to the maximum strain ϵ_{Max} measured during the test. The sizing with respect to damage tolerance is therefore simply reduced at all points of the structure to the relation:

$$\epsilon_{\text{Structure compression}} < \epsilon_{\text{Max}}$$

In this context posed by aeronautics, numerous studies have been carried out in order to better understand and model the phenomena involved. Only a few are mentioned here - in particular the summary work of the FAA or NASA [39–43]. When an aeronautical sandwich structure receives an impact, the damage to the skins is similar to that on composite laminates but the core is crushed locally (see Fig. 7). The crushing of Nomex honeycomb structures is very complex, with wrinkling, tearing and damage to the phenolic resin layer [46]. This complex behaviour can be modelled according to various strategies [40,44]: detailed model [45], discrete strategies based on nonlinear springs [46–50] or damage mechanics using an orthotropic continuum [51,53]. When damage after impact is well captured, it is relatively easy to develop efficient models for compression after impact. The criteria for failure are most often maximum strain criteria on the skin [51] or the more original

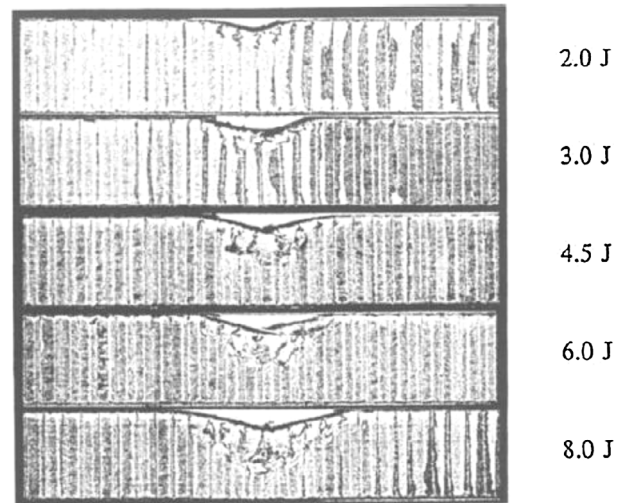

Fig. 7. Impact damage on an aeronautic sandwich for several energy levels (reproduced from [9]).

core crush criterion [52]. The behaviour in compression after impact is well understood. It is a combination of 3 non-linearities: a geometric non-linear coupling with the indented zone, which will cause local bending and compress the honeycomb; a non-linear response to the crushing of the honeycomb; and, finally, the damaged behaviour within the composite skins or the plasticity of metallic skins. Unlike rigid bodies, which tend to create a dent shape similar to the impactor, soft bodies create an almost uniform core crush under the impact zone. This type of impact seems to be more severe for the structural strength of the sandwich panel [54].

1.4. Joining sandwiches

Although, for composite structures in general, it is said that "the best way of joining is no joining", in practice, making joints is inevitable. The first type of joint considered here is sandwich to sandwich with T, L or edge to edge joints [55–62] for example). There are numerous technological possibilities, which must be examined before determining an optimum in a given context. Feldhusen et al. ([57] and Fig. 8) analysed 783 initial solutions before converging on only 18 "promising concepts" according to the following criteria:

- The connection must be able to transmit all forces and moments that occur.

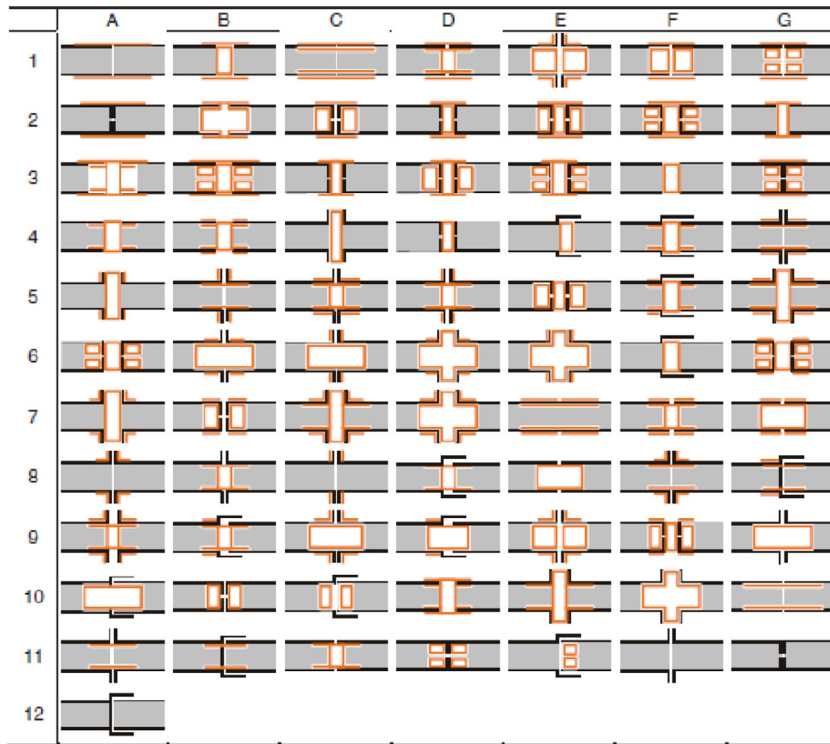

Fig. 8. Edge junctions (from [57]).

- The dimensions of the joint shall be as small as possible yet as large as necessary.
- Elastic deformations that will occur under load must not become so large as to harm the joint.
- The principle of uniform strength shall be applied to sandwich elements and joint. The fatigue life of all parts involved shall be the same.
- The joint shall be as lightweight as possible.
- The intersection area between sandwich and joint shall be designed in such a way that sharp deflections of the force flowlines or strong changes in their density are avoided.

Another interesting study worth mentioning is that of the Robust Composite Sandwich Structure (RCSS) programme carried out in the USA in the late 1990s for the design of an F22 fighter plane structure. The design criteria were: load transfer, producibility, durability, reparability and fuel sealing [56].

Another very effective way to achieve the junctions is to design a skin to laminate transition. The joint is offset into a laminate, which is simpler to design and more robust (see Fig. 2 and Fig. 9, solution 12, [63–68]). Although not chosen for the RCSS programme, this type of solution is widely used in helicopters or convertibles [11,16,65] for both symmetrical and asymmetrical sandwiches. Despite its interest, this type of solution has been little studied because it generates additional complexities with numerous nonlinear couplings that can generate premature failures. In addition, it is an area that transfers loads and must be sized accordingly, especially in the presence of reinforcing plies [34].

The most commonly used joining method for sandwiches, whether for aeronautics or space, is the use of inserts [69–83]. An insert is a local reinforcement of the core that makes it possible to tolerate concentrated forces, most often via bolts. Inserts can be used either to join sandwiches together, to join a sandwich part to the rest of the structure (highly working inserts) or to fix systems, cables or hydraulic pipes (low working inserts). Their study is still largely semi-empirical, being based either on experimental results given by suppliers or on analytical models [69–71] that are sometimes very efficient [72–73]. These approaches have the main drawback of remaining linear and therefore very far from

the complex failure scenarios identified in the literature [74–77]: buckling, postbuckling and tearing of Nomex Honeycomb cores, compression and crushing of the potting, punching of the skins, local debonding (see Fig. 10). These phenomena are also difficult to tackle because there is a strong dispersion linked to the manufacturing methods, which generate numerous defects [78–80]. In the rare recent papers, two modelling strategies are employed: refined honeycomb models [81] or even lighter models using damage mechanics and volumic elements [82], which allow the creation of failure mode maps [83]. It is interesting to note that, according to Mezeix et al. [84], the pull-out behaviour after impact of the inserts is very good, with limited reduction of the order of 10-15%.

1.5. Manufacturing and control, repairs, moisture and other issues

Manufacturing

There are three usual ways of making sandwich structures in an autoclave to ensure aeronautical quality:

- Co-curing: both skins fresh and bonded to the core, with or without an adhesive film, during curing (One curing).
- Co-bonding process: one skin cured, another fresh bonded to the core while curing (Two curings).
- Secondary bonding: the two skins are cured separately and then bonded to the core with an adhesive film (Three curings).

Usually, the curing pressure in the presence of Nomex honeycomb is limited to 3 bars to avoid core crush, especially in the rampdown area [85]. Despite the importance of the subject in practice, a limited number of studies have been published, probably because, even today, the manufacture of composite structures relies heavily on industrial know-how, which is jealously guarded. In 1997, Karlsson and Astrom [86] presented and made a qualitative comparison of the main technologies available to make sandwich structures, in particular in the naval and aeronautical industries. D. A. Crump et al. [87] compared the methods in and outside autoclave for the manufacture of secondary structures and found that the method outside autoclave (Resin Film Infusion) offered the best economic equation. The problem of the air trapped in the closed cells of

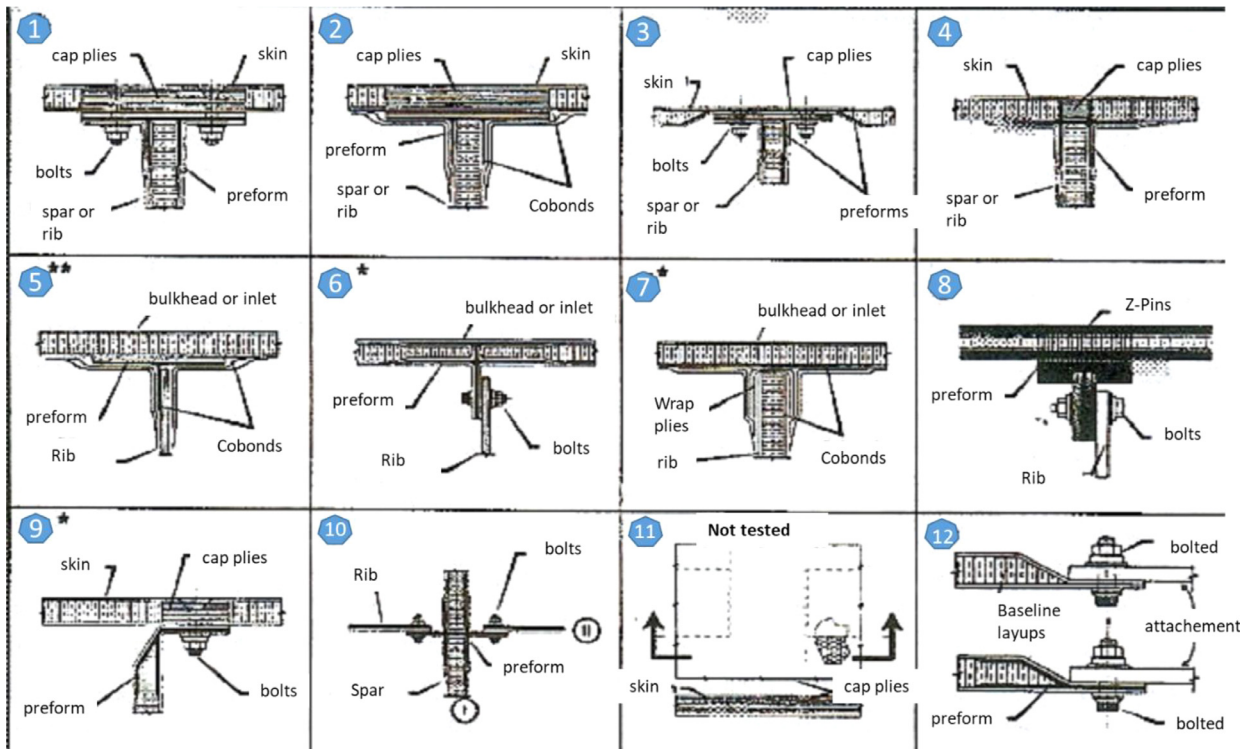

Fig. 9. Robust composite sandwich structures (reproduced from [56]).

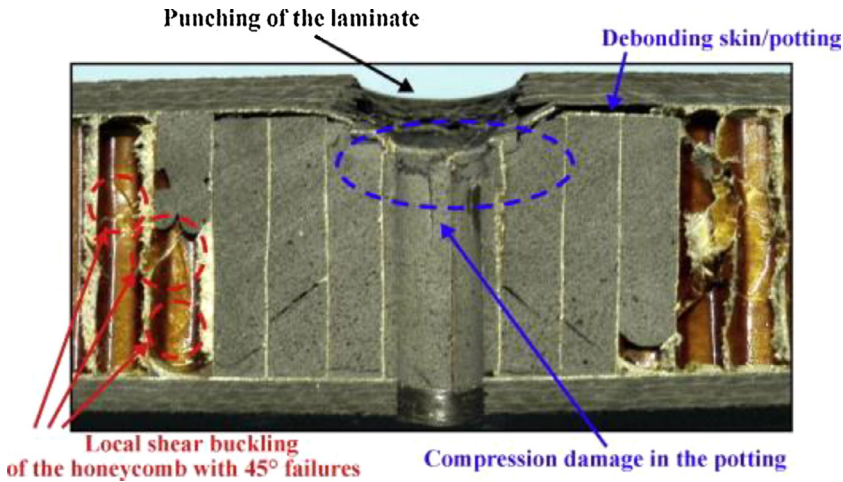

Fig. 10. Failure pattern of an aeronautic insert used for landing gear door under pull-out loading (reproduced from [76]).

the honeycomb was also studied and modelled, paying particular attention to studying the evolution of the pressure during curing [88–92]. In a recent study, Anders et al. [93] showed spectacular films of the polymerization of the adhesive film according to the parameters of curing and the good or bad realization of the menisci, thus confirming the empirical findings of the industry. Unlike the situation for laminate [94], there is no advanced thermokinetic, thermochemical or thermomechanical model of the curing of aeronautical sandwiches that can be used to predict shape defects after spring-back [95] or spring-in [96]. The available studies are essentially thermomechanical and analytical [97–100]. Another common manufacturing defect is called “telegraphing”. It is a shape defect involving local undulation with respect to the honeycomb cells. However, aeronautical structures are less concerned than space structures because the technological minima are at least two plies for the skins and the cell sizes are small.

Despite the necessarily limited extent of this bibliographical overview, it is clear that, given the current state of the art in the modelling of laminate curing, much research remains to be done with regard to the manufacture of sandwich structures. This action could also promote their development by securing industrialization.

Non-destructive testing

In aeronautics, all structural parts must be checked to ensure their initial quality. In the certification process of the Beechcraft Starship [10], it is stated: “Acceptance criteria were established for structure with porosity, voids, and disbonds to account for initial quality (flaws) developed during the manufacturing process. Damage modes such as porosity, voids, and disbonds were subjected to specified acceptance criteria. This initial quality is intrinsic to the manufacturing process and the inspection standards and represents the as-delivered state, and therefore, the structure must be capable of meeting all requirements of strength, stiff-

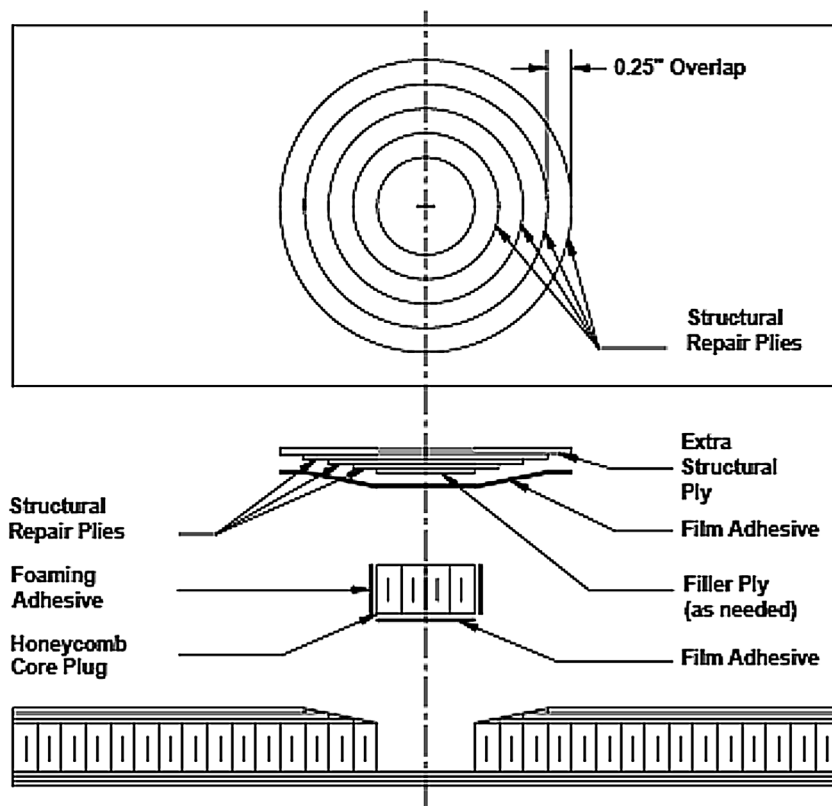

Fig. 11. Schematic of a scarf repair applied to a sandwich component. Top: top view, bottom: section view (Reproduced from [103]).

ness, safety, and longevity with this initial quality". Today's inspection methods in an industrial context are mainly: visual inspection, ultrasonic and X-ray inspection, [101,102]. The Manual Tap Test, Automated Tap Test, Mechanical Impedance Analysis and C-Scan have been compared [103] and, according to the authors, "The more sophisticated the method, the more accurate it was in determining the size of the damage". The acoustic methods are mainly used to determine the manufacturing quality of the skins or to detect skin/core separation. These methods are generally difficult to implement in the case of sandwiches and require good know-how. Others exist, such as infrared or holographic methods [104], but are less in use in industry.

Repair

In line with the damage tolerance policy (see Fig. 5 and [10]), as soon as damage is detected, it must be repaired. Repair instructions according to the type of damage are given in the SRM (Structural Repair Manual) of the various manufacturers. The principles of repair are explained in [103–107] according to whether the damage is minor or major and a typical repair is shown in Fig. 11. Although the repair principles may be simple, the sizing of these repairs is complex and concerns the scientific problems of bonded joints with complex geometries [103–112]. Despite everything, if correctly carried out, repairs allow more than 90% of the initial resistance to be recovered, even in the case of repeated impacts [109]. Thus, for gliders, the lifetime can reach 50 years with repairs.

Moisture ingress

Sandwich structures have a bad reputation because a number of problems or incidents have been reported in the open literature [113] and probably many more by rumour. The problem is most often linked to closed honeycomb cells that trap moisture. The humidity can then cause patches of corrosion on the metallic honeycomb cores, decreases in the resistance of the bonded joint between the skin and the core, or degradation of the Nomex during the freeze-thaw cycles that accompany changes in external temperatures during flights [113–118].

The causes of moisture diffusion can be linked to the very nature of hydrophilic epoxy resins [116], to poor design of the core closure, to

poor sealing after a repair, or even to impacts below the BVID [114]. From [151], the US Navy banned the use of aluminium honeycomb on the V22 and F/A 18 programmes. However, as the number of flying sandwich structures shows, these problems are perfectly manageable [114]. One method is to design the skins with a minimum number of plies of fabric on the sandwich to ensure a good seal. For certification authorities, Water Ingression Tests were required for the certification of the Beechcraft Starship [10]:

"Twelve-inch-square panels with inflicted punctures of one face sheet were immersed in water to allow water into the core in the punctured regions. They were then subjected to freeze/thaw cycles with vacuum applied during freeze to simulate high altitude flight and then inspected to ensure that water did not propagate beyond the punctured regions."

1.6. Summary

In this section, the main problems specific to the design of aeronautic sandwich structures have been briefly presented. Others, like lightning strikes or certification tests, have voluntarily not been treated because they are generally handled in a similar way to those on laminated structures [10]. It is clear that the potential gain offered by sandwich structures is very large but their complexity is greater and they must be approached with prudence and humility and, if possible, by capitalizing on experience to guarantee success. In the following historical developments, we will grasp this complexity through a number of examples. From the researcher's point of view, it is interesting to note that many areas, from calculation to manufacturing and environmental effects, remain to be studied and improved.

2. The very beginning: Wood construction

According to Professor HG Allen [119], civil engineering has used sandwich construction (called "double skin" at the time) since 1849 and several sources claim that a patent may have been taken out in 1915 by Hugo Junkers (Professor at Aachen university and the future

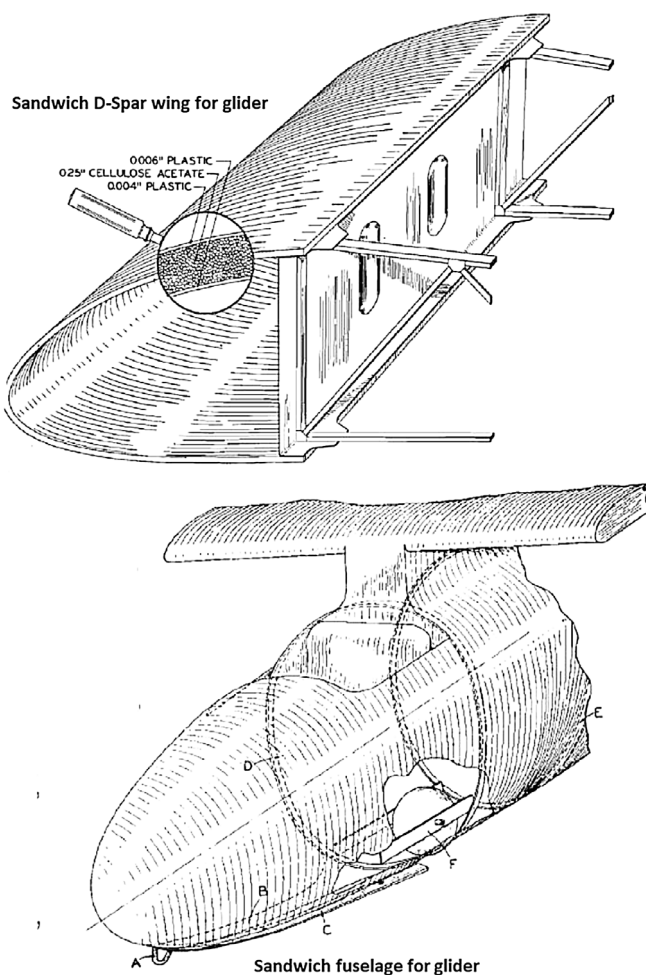

Fig. 12. Glider wood sandwich construction (reproduced from [123]).

father of the Ju-52) for a sandwich structure with honeycomb core. However, as far as the authors know, he never went on to exploit it for his own aircraft [120]. In 1924, a patent for a glider fuselage was filed by Theodore Von Karman himself and P. Stock [121] and is cited in the papers of Nicholas J. Hoff [1,122,123]. According to Hoff, “It indicates that the gliding society of the Polytechnic Institute of Aachen must have planned, if not built, a fuselage having a sandwich skin”. Thus, gliders were probably the first flying structures to have a full sandwich construction. The required criteria were: aerodynamic refinement, light weight, inexpensive production, sturdiness and ease of repair, and also manufacturing ability to make double curved structures. The manufacturing process used a wooden mould and a large number of clamps. The mould was lined with metal resistance heating pads, the temperature of which was controlled by a thermostat. A uniform pressure was maintained by means of a vacuum bag to cure the thermosetting phenol-formaldehyde glue that was used. It is important to note here that the first development of a wood sandwich structure was rooted in the application of efficient glues for bonding woods. The urea-formaldehyde adhesive known by the commercial name of “Aerolite” was developed by De Bruyne [124], who would later invent the Redux films.

A sandwich D-Spar and a typical fuselage of a glider of the time are shown Fig. 12. It is remarkable that the advantages of sandwich or composite structures, such as the simplification of the design and the reduction in the number of parts, were already highlighted as indicated by the sleek design of the D-Spar. According to Hoff and Mautner “an interesting design feature is the local reinforcement of the structure to with-

stand the concentrated loads imposed by towing and landing. Back of towing hook A and above skid C in the region marked B, the core of the sandwich skin is spruce. The density of this spruce insert is changed through the application of compression during the manufacturing process in such a way that the specific weight is 1.2 near hook A while it decreases gradually to 0.5 near bulkhead D. Elsewhere the core is balsa with its thickness decreasing from the highly stressed bottom portion of the fuselage toward the lightly stressed top portion. The wing is attached to the two main frames D and E of the fuselage. Between the frames two beams F are arranged to support the landing wheel”. It should be noted that the example given in [123] and reproduced here is not dated and is probably related to Second-World-War or earlier gliders. Today’s glider structures are still made with thin sandwich but the cores are of foam and the skins of glass or carbon.

Some parts of aircraft were punctually manufactured with wood-based sandwich structures in the nineteen-thirties. Hoff [122] reported pontoons of the Sundstedt plane developed in the USA in 1919, the Skydine aileron in 1939, the fuselage of the De Havilland Comet (DH 88) in 1934 and De Havilland Albatros in 1938 and the wings of a French airplane developed by SE. Mautner in 1938. The De Havilland Albatros DH 91 was a four-engine transatlantic mail plane able to carry 22 passengers, which made its first flight in 1937 (see Fig. 14 (a)). The sandwich was designed with plywood skins and a balsa core. For the French aircraft, a French patent, “the Brodeau process”, dating from 1934 is detailed in [125] (see Fig. 13). The sandwich is made up of 2 plywood skins and a cork core drilled with holes to optimize the mass. This process is believed to have been applied to a Lignel aircraft in 1938.

It is not well known that the Morane-Saulnier 406 (see Fig. 14 (b)), a single-seat interceptor fighter built France, which first flew on August 8th, 1935, was designed with a wing made of “Plymax”. This is a sandwich structure with aluminium skins and an Oukoumé plywood core. However, this technological choice was complex from a manufacturing point of view and penalized the ramp-up in production of the aircraft. In addition, this aircraft proved to be inferior to the Messerschmitt Bf 109 in the Battle of France in 1940. This type of plywood/aluminium structure has also been rediscovered recently and shows very good mechanical qualities [126] in compression and compression after impact [127].

The plane that is most famous and most cited for its plywood skin and balsa core sandwich structures is the de Havilland “Mosquito” DH 98 (see Fig. 14 (c)). It turned out to be one of the best planes of the Second World War, both for its pure performance and for the extraordinary missions it achieved. As Professor HG Allen notes in [119], it is often wrongly presented as the first plane with primary parts in sandwich structures. However, its design comes from the experience acquired by de Havilland with the DH 88 and DH 91. It is very similar to the DH 88, which had been proposed to the British War Ministry in a light bomber version but refused. However, de Havilland persisted and showed foresight in anticipating the aluminium shortage that occurred during the Second World War.

The detailed design of the structure is perfectly explained in [128] and reproduced here: “Like the Comet and Albatross mainplanes, de Havilland constructed Mosquito mainplanes out of shaped pieces of wood and plywood cemented together with Casein glue. Approximately 30,000 small, brass wood screws also reinforced the glue joints inside a Mosquito mainplane (another 20,000 or so screws reinforced glue joints in the fuselage and empennage). The internal mainplane structure consisted of plywood box spars fore and aft. Plywood ribs and stringers braced the gaps between the spars with space left over for fuel tanks and engine and flight controls. Plywood ribs and skins also formed the mainplane leading edges and flaps but de Havilland framed-up the ailerons from aluminium alloy and covered them with fabric. Sheet metal skins enclosed the engines and metal doors closed over the main wheel wells when the pilot retracted the landing gear. To cover the mainplane structure and add strength, de Havilland woodworkers built two top mainplane skins and one bottom skin using birch plywood. The top skins had to carry the heaviest load so the designers also beefed them up with birch or Douglas fir stringers cut into fine strips and glued and screwed between the

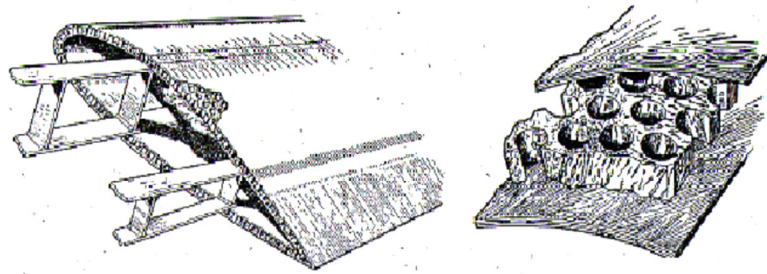

Fig. 13. "Brodeau" process, 1934 [125].

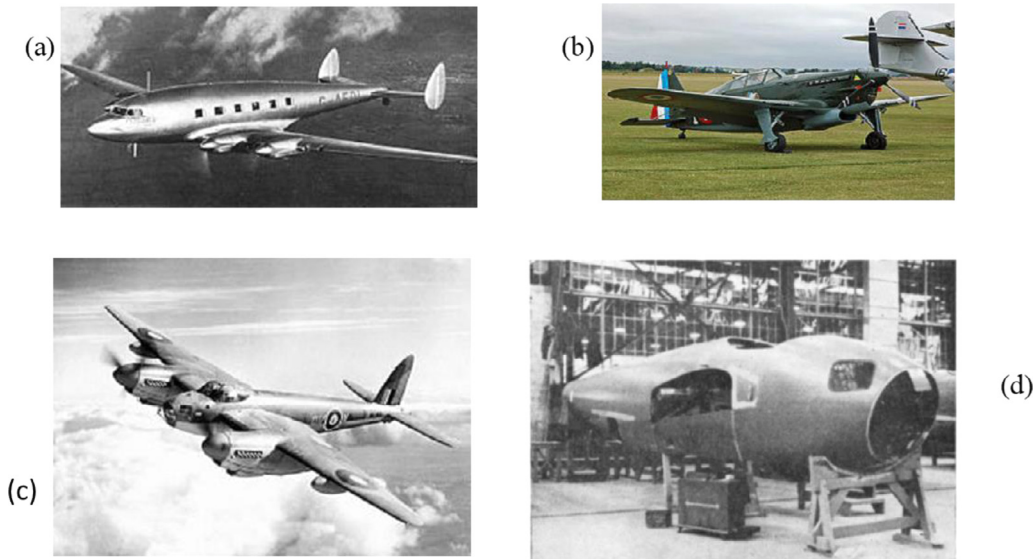

Fig. 14. Pictures of some aircraft with sandwich structures (a) de Havilland 88 "Albatros", (b) Morane Saulnier 406, (c) de Havilland 98 "Mosquito", (d) Sandwich type moulded fuselage (Pictures (a), (b), (c) from Wikipedia, (d) from [122]).

two skins. The bottom skin was also reinforced with stringers. Together the top and bottom skins multiplied the strength of the internal spars and ribs. A Mosquito mainplane could withstand rigorous combat manoeuvring at high G-loads when the aircraft often carried thousands of additional pounds of fuel and weapons. To maintain strength, trim weight, and speed fabrication time, the entire mainplane and spar was finished as a single piece, wingtip to wingtip, with no break where the wing bisected the fuselage. A finished and painted mainplane was light and strong with a smooth surface unblemished by drag-inducing nail or rivet heads."

It is quite remarkable to see that the construction was really optimized in terms of "stacking" according to the areas of the aircraft, with a simple birch plywood skin for the underside of the wing and a sandwich construction for the upper side. Manufacturing was a one-shot process, which is now sought by manufacturers to reduce costs (see Fig. 14 (d)). There are also glued / bolted joints that are still used today in certain structures of military helicopters and are the subject of active research to reduce the number of fasteners and bring down costs ([129, 130] for example). For these reasons, beyond just sandwich structures, the Mosquito is one of the most important precursors of modern, composite-structure planes.

3. Sandwich honeycomb structures for MACH 2 and MACH 3 aircraft

In the 1950s and 1960s the Cold War raged on and authorized the development of extraordinary aircraft programmes in the United States (and probably also in the USSR, but the author has no information on Soviet aircraft). The first that caught the attention in this article is the

Convair B-58 bomber, which made its first flight on November 11th, 1956 and which could reach Mach 2.4. One hundred and sixteen B-58s were built before the bomber was withdrawn from operational service in 1969. The structure was extremely light, making up only 0.24 per cent of the aircraft's gross weight, an exceptionally low figure for the era [56]. It was lighter than later aircraft (F 16: 0.328, F14: 0.422, F15: 0.361). The detail of its structure is explained in [131]. The wing surface consisted of a sandwich structure with aluminium skins and a phenolic resin fiberglass cloth honeycomb core. The use of this type of sandwich allowed sealing, thus reducing the number of spars in the wing while enabling operation between -55°C and + 126°C. A specific adhesive that could create a meniscus was developed to make this sandwich. For the fuselage, this type of structure was also used, except for the hottest parts, which were made with a sandwich having stainless steel skin and a honeycomb core.

The XB-70 "Valkyrie" was a MACH 3 supersonic bomber studied and manufactured (in only two prototypes) by North American Aviation (NAA), see Fig. 15. The first flight was on September 21st, 1964. Due to its MACH 3 speed, the skin temperatures ranged from 246°C to 332°C. To avoid using rare and expensive titanium, NAA used a stainless steel honeycomb sandwich skin (see Fig. 15), which proved to be very efficient, not only from a structural point of view but also for thermal insulation (especially for fuel tanks) at high speed with a low weight penalty [133]. It was also interesting for aerodynamic smoothness and acoustic fatigue in the inlet. It covered a surface area of 2000 m², 68% of the airframe [134]. The sandwich used was all stainless steel and the skins were brazed to the honeycomb in the same alloy following the explanations provided in [135]:

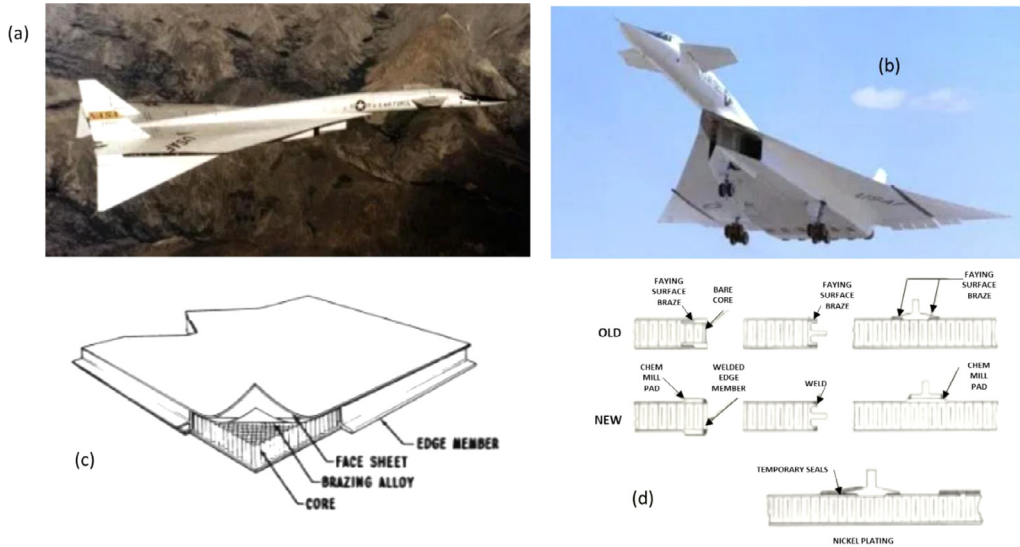
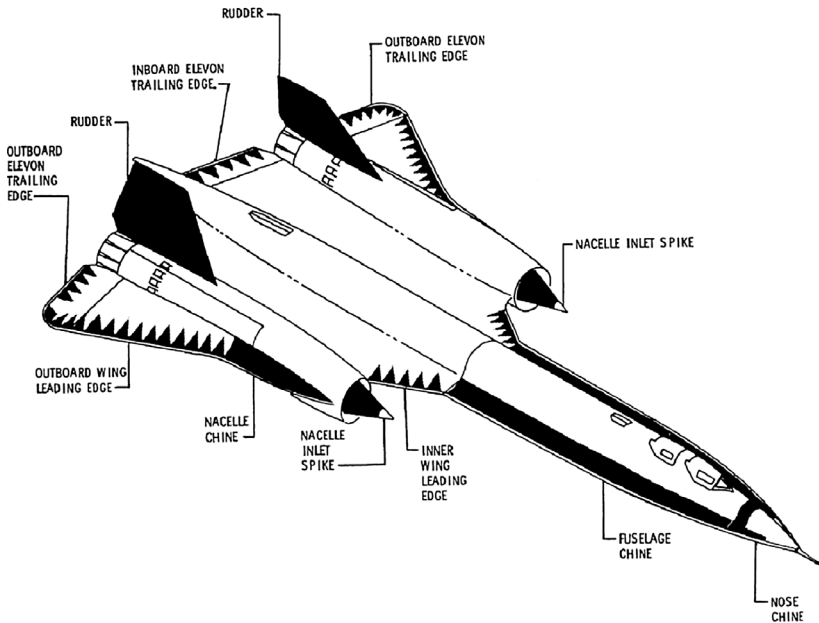

Fig. 15. (a) and (b): Pictures of the XB 70 from [136], (c) typical sandwich construction from [135], (d): improved design for sealing from [134] and [137].

Fig. 16. Composite Honeycomb areas of the SR 71, shown in black (from [139] and [140]).



- 1) preparing the basic components (core, skins, brazing foil, closeout edge member if any)
- 2) Assembling these elements under surgically clean conditions
- 3) Placing the assembly in an airtight steel container, called a retort, which is then evacuated and subsequently filled with an inert gas, such as argon.
- 4) Placing the retort containing the panel in a heat source for the actual brazing process.

After different trials, the electric blanket brazing method was preferred. It took about 15 minutes for a panel and the temperature reached about 950°C to make the weld. Then the temperature was carefully reduced and a second cure was carried out for metal treatment.

However, the process was not immediately efficient and some skins became detached in flight, fortunately without causing irreparable damage. Similarly, improvements to the process were subsequently implemented to guarantee the sealing of the tanks (see

Fig. 15). The complete history of this aircraft can be found in [132].

Despite the programme being downgraded to a research programme, probably because of its cost and the arrival of intercontinental missiles, the aircraft satisfied the initial requirements, and the technologies for making the sandwiches, which took 5 years to develop, have spread to many other programmes (727, C141, Apollo and the Saturn space vehicle) and created numerous spinoffs. For example, the brazing alloy was later used to attach carbide and tungsten carbide tool faces [135]. Later studies were carried out on titanium sandwiches brazed for a supersonic transport plane were carried out ... but the results were not used in practice because of the withdrawal of the programme [138]. Concorde, which flew for the first time in 1968 and reached MACH 2.2, also used aluminium sandwiches for its rudder [132] and carbon skin sandwiches for ailerons. The total mass of composites for the aircraft already reached 500 kg [162].

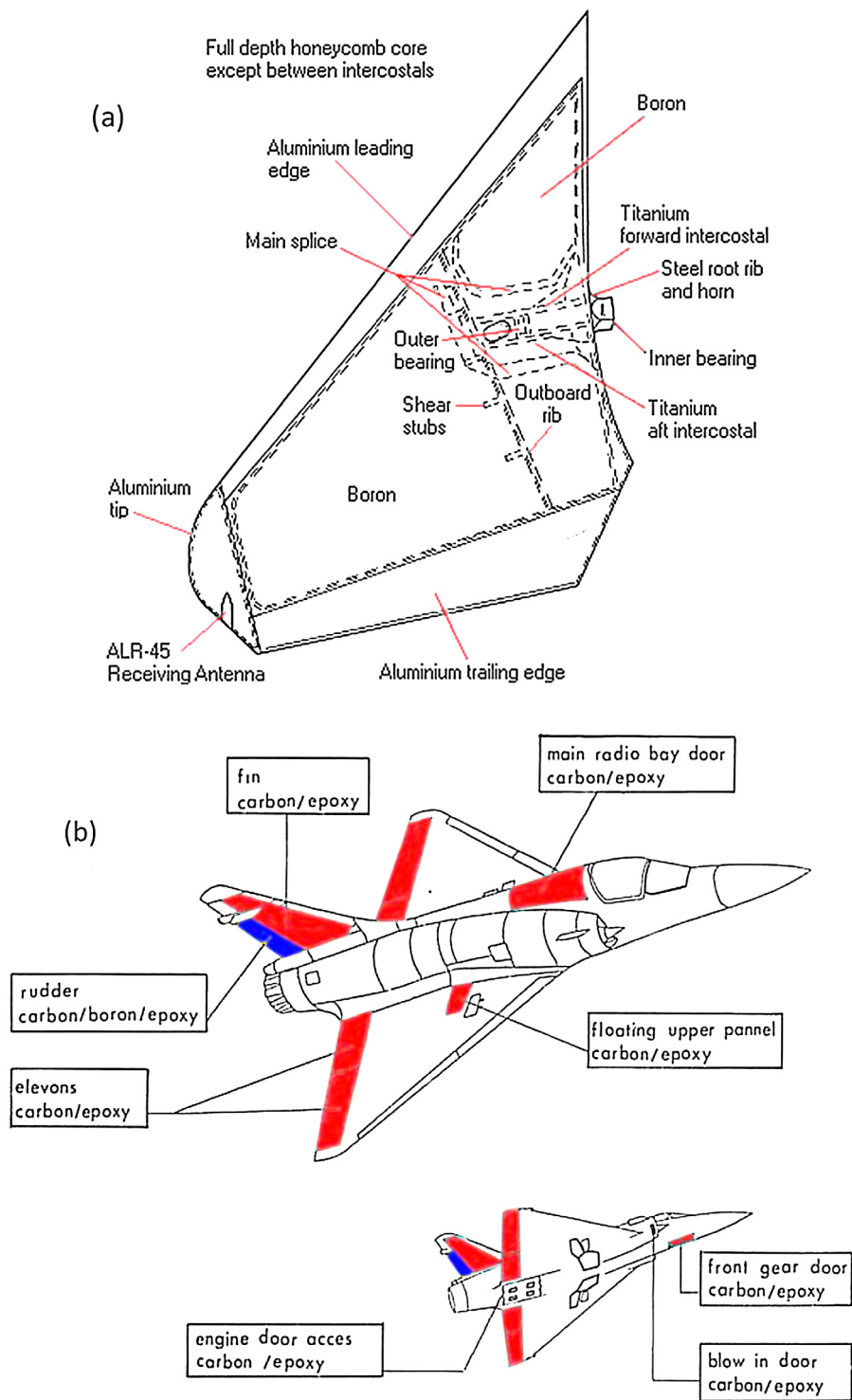

Fig. 17. (a) Horizontal stabilizer of F14 made with boron/epoxy skin and aluminium honeycomb core, (b) Dassault Mirage F1 carbon and boron sandwich structure overview.

It is not possible to give even a rapid overview of this period and this type of aircraft without mentioning the famous SR 71 “Blackbird” [141]. Despite the extremely high surface temperatures, which meant that the structure was mainly made of titanium (unwittingly provided by the Russians), some parts of the SR 71 were made of a sandwich composed of asbestos skins / fiberglass, aluminum nida core (according to [140]). These parts were non-structural but designed to provide stealth functions as shown by the triangular shapes in Fig. 16. After the first titanium versions, this material was also used for the 2 rudders.

4. Secondary composite sandwich structures

Safety being one of the main constraints in aeronautics, the introduction of sandwich materials with composite skins was performed very gradually in civil aviation, starting with the non-structural parts like interior parts, sidewalls, bag racks, and galleys, or flooring (which is still in use today [81]). These were followed by secondary structures like spoilers, rudders, ailerons, and flaps, and finally the primary structures, which will be discussed in the next section [142,143]. In this sense, military programmes served as precursors, and composite sand-

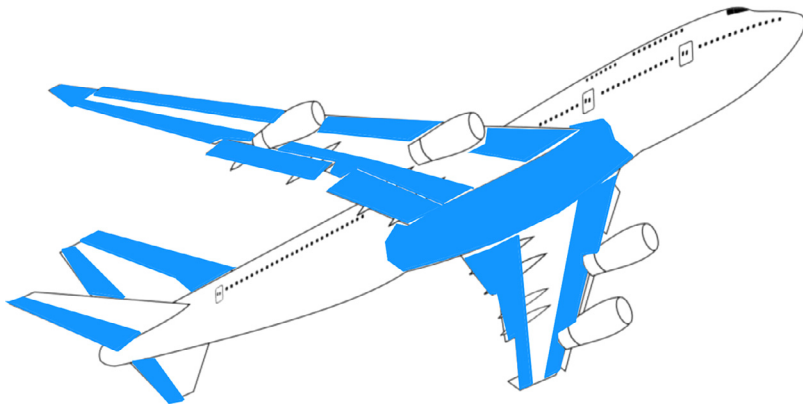

Fig. 18. B747 overview of sandwich structures.

wich structures have been successfully applied in many military programmes around the world since the 1960s, when fibres of boron and carbon began to be available. In the annex of [146], a comprehensive review of composite parts made for research or production is provided but, most of the time, it is not stated whether the design is in sandwich or not. However, plane-by-plane research has revealed that secondary structures such as the landing gear door, speed brake, flaps, and rudder, were built in aluminium honeycomb / boron-epoxy skin and were applied to programmes like the McDonnell F4, Northrop F5, Douglas A4, General Dynamics F111, Grumman F14 (see Fig. 17) and many others.

In France, the Dassault Mirage F1 horizontal stabilizers were also made with boron epoxy skins and aluminium honeycomb core, for example. In fact, until the mid-1970s, boron fibre was indeed cheaper and more available than carbon fibre. However, carbon fibre very quickly supplanted it and many carbon sandwich applications started, as on the Mirage 2000 (first flight March 10th, 1978). In Fig. 17 (b), the fin, rudder and aileron are made of sandwich structures with aluminium honeycomb. However, from the Mirage 4000 onwards, the fin was built in monolithic self-stiffened laminate made of T300-914 carbon-epoxy plies [147].

As far as large civil aircraft are concerned, the Boeing 747 (first flight February 9th, 1969) is designed with a large proportion of sandwich (see Fig. 18). It has about half the surface of the wing, including the leading and trailing edges, made of glass fibre and Nomex honeycomb, which is also used for the large belly fairing. Most of the flaps are made with the same sandwich but aluminium honeycomb and skins are also used. However, the wing box, the vertical tail box and the fuselage are still made of aluminium stiffened panels.

The use of composites has since increased significantly with, in particular, the ATR 72 (first flight on October 27th, 1988), which was the first civil aircraft to have a carbon primary structure (the wing box) certified [36]. It also incorporates many composite sandwich structures for secondary structures but with a wide variety of skins: glass, Kevlar and carbon (see Fig. 19).

These solutions have also been applied in the A320, A330 and A340 programmes. However, in the most recent programmes, the proportion of sandwich materials in secondary structures has been decreasing, as shown in Fig. 20. For the A380, the Boeing 787 or the Airbus A350 only the belly fairing, the nacelles, the front landing gear doors, some ailerons and the rudder are still made with sandwich structures [144,145]. The other parts are self-stiffened monolithic structures, which certainly present an economic advantage today.

5. Primary composite sandwich structures

The most famous aircraft in sandwich structure is the Beechcraft Starship, which made its first flight on February 15th, 1986 [10,149–152]. It was the first in its category and it has greatly helped to reclaim the field and contributed valuable experience, which has been beneficial

not only to Beechcraft but also to the entire aeronautical industry. As Kevin Retz points out [152]: “Only 53 Starships were produced before production ended in 1995. This could not be considered a financially productive program but it gave Raytheon/Beech a very sound foundation to build on. Beech used this to win C17 contracts, and on its other aircraft. For Raytheon the Starship proved to be a bonanza of knowledge”. The Starship configuration was originally conceived in 1982 by Burt Rutan and went into production in 1988 [151]. It was certified on June 14th, 1988 and was the first “all composite” aircraft certified by the FAA, four years later than originally scheduled. About 72% of the mass of its structure was in the form of composite material, mainly epoxy carbon skins and Nomex honeycomb cores in HEX, OX or FLEX forms. The density was 48 kg/m³ but it could reach 72, 90 or 144 kg/m³ locally. The fuselage was made up of two manually draped half-shells, while the wing covers were 16 m long one-shot pieces. It is interesting to see the number of tests that were necessary to certify this aircraft [149]:

• Full scale static tests.....	99
• Environmental effects, full scale and components	29
• Damage tolerance, full scale and components (9 × 2 lifetime).....	360 000 h
• Residual strength after fatigue.....	18
• Joints testing.....	335
• Parts.....	20
• Buckling panels.....	39
• Delamination panels.....	72
• Impact panels.....	160
• Solar effect.....	47
• Coupon level.....	8000

The number of tests, and thus the cost of certification, was very high. More details on these certification tests are given in [10]. In this paper, a typical stacking technique merging unidirectional tape and plain weave is shown (see also Fig. 22). Note also the presence of a copper mesh on the surface for lightning strikes. The certification process is almost the same today with several tens of thousands of tests for the A350. The development was difficult because the FAA regulations on damage tolerance evolved during the programme, generating delays. In addition, a premature failure occurred during structural testing and the structure therefore had to be modified in depth. The entire manufacturing process also had to be certified [151].

However, many lessons were learned from this experience and led to the success of the Raytheon Premier. The fuselage is similar to that of the Starship (see, for example, two typical stacking sequences for these two planes in Fig. 22 [10]) but, for the Raytheon Premier, it is obtained by Advanced Fibre Placement (AFP). In addition, the manufacturing method was studied well before the certification process by combining the experience gained on the Starship and that of the AFP machine manufacturer (Cincinnati). According to Kevin Retz [152]: “The entire fuselage is made in two pieces and weighs less than 600 lbs (272 kg); this is a weight saving of over 20 % when compared with a metallic aircraft.

Fig. 19. ATR 72 composite materials.

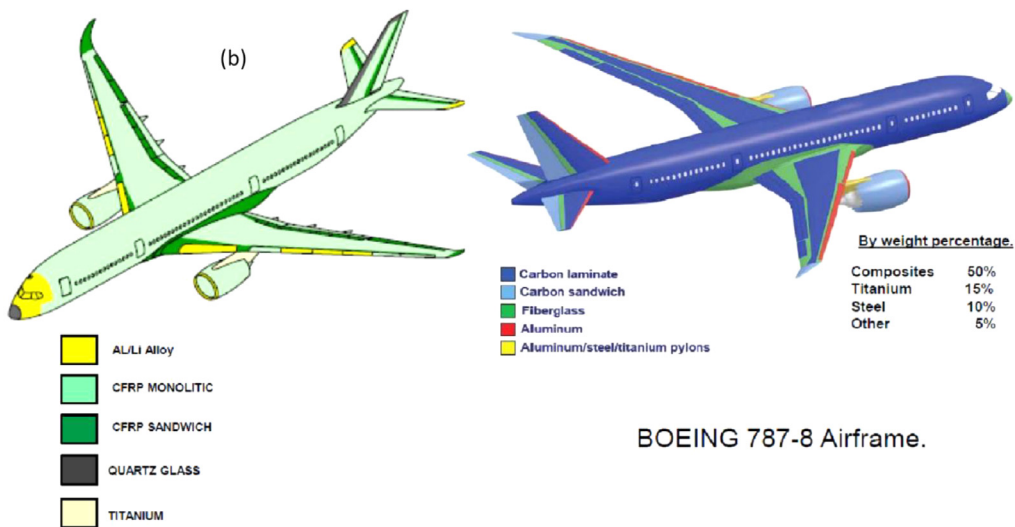
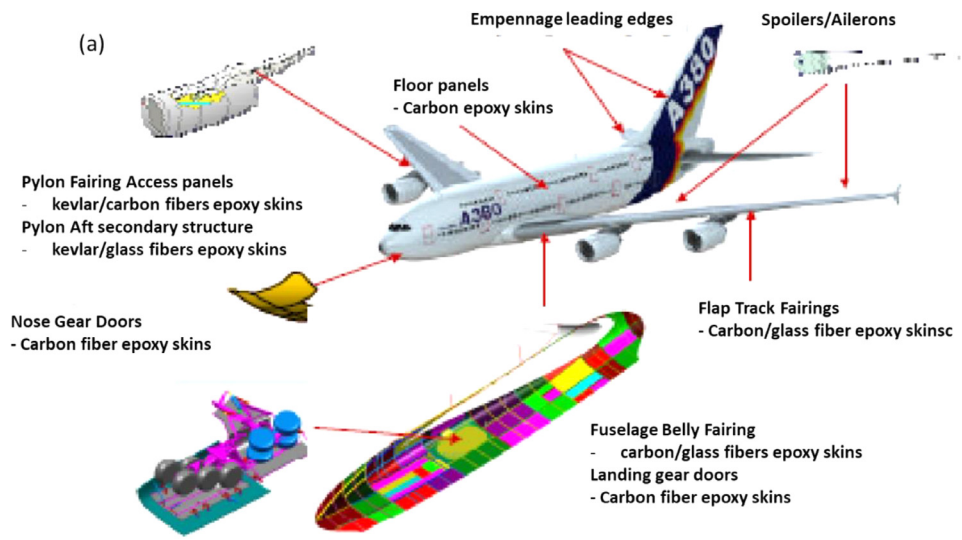
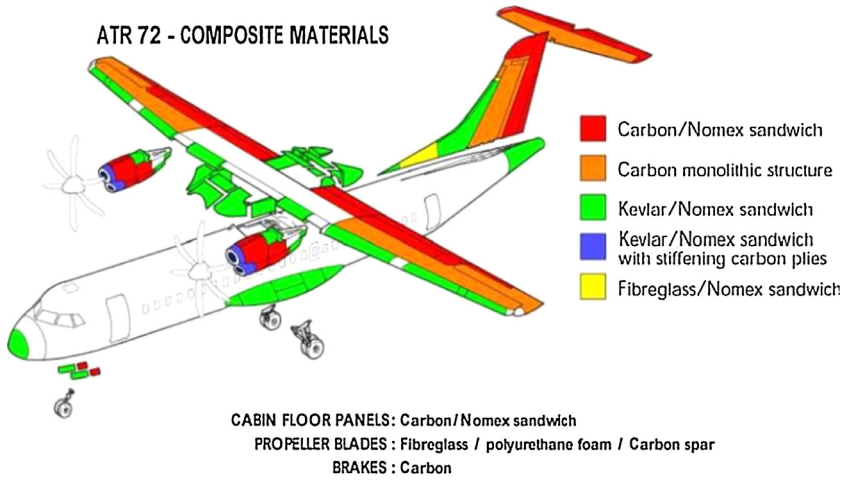

AIRBUS A350-900 XWB Airframe.

BOEING 787-8 Airframe.

Fig. 20. (a) Sandwich structures in A380 [144], (b) Sandwich and composite structures A350 and B787 composite Aircraft [148].



Fig. 21. Left: Beechcraft Starship NC 51 in flight, Right: Fuselage under construction (from [150]).

(a) Typical Stacking sequence for Beechcraft STARSHIP

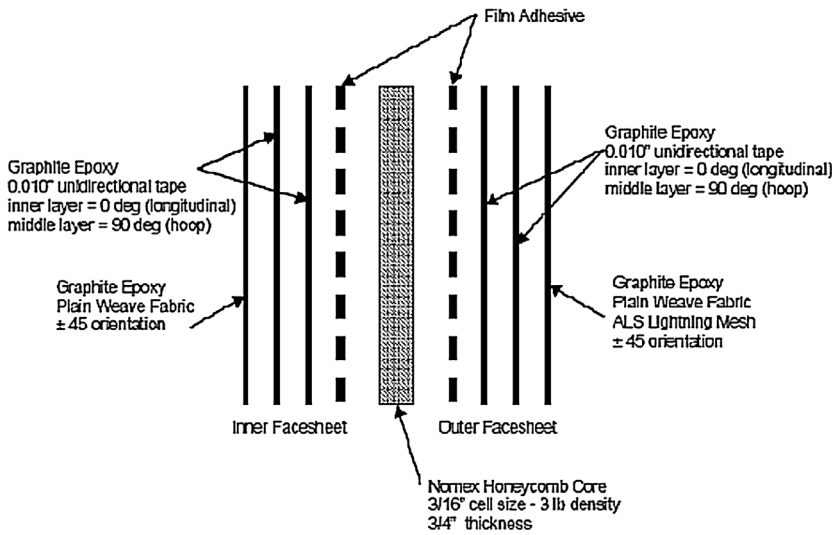
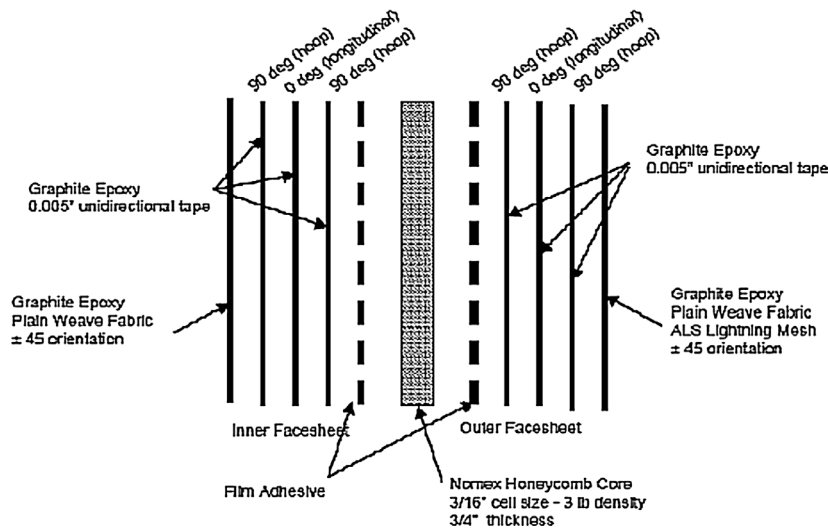

Fig. 22. Typical stacking sequence for pressurized fuselage: (a) for Beechcraft Starship (b) for Raytheon Premier (reproduced from [10]).

(b) Typical Stacking sequence for Raytheon Premier



With the combination of advanced fibre placement and large hand layed-up parts, the Premier I has reduced the parts count from 16000 parts down to around 6000 parts for the entire aircraft, a reduction of over 60 %. By using fibre placement, material scrape rate is below 5% compared to 50% for a hand-lay-up fuselage... production costs were reduced by 30 % for

the fuselage. To see this factor clearly, it takes 4 technicians less than one week to produce the entire fuselage". However, the wing of the Premier remains in aluminium. Other aircraft have followed this example, such as the ADAM Aircraft A500 & A700, the CIRRUS SR 20 & SR22, which are also business jets. These programmes have benefited from the data

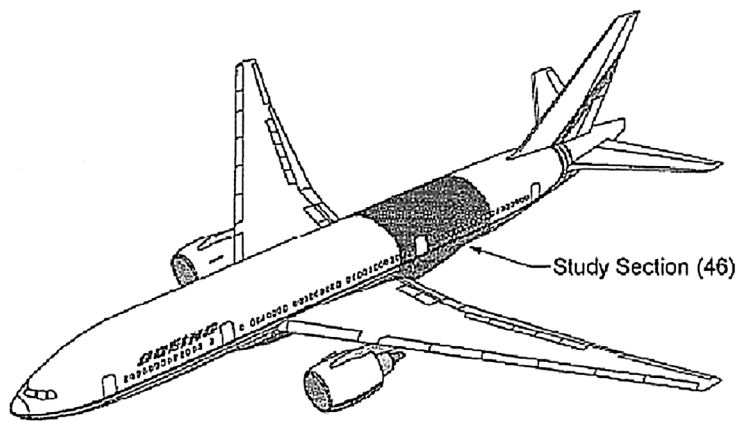

Baseline vehicle and study section.

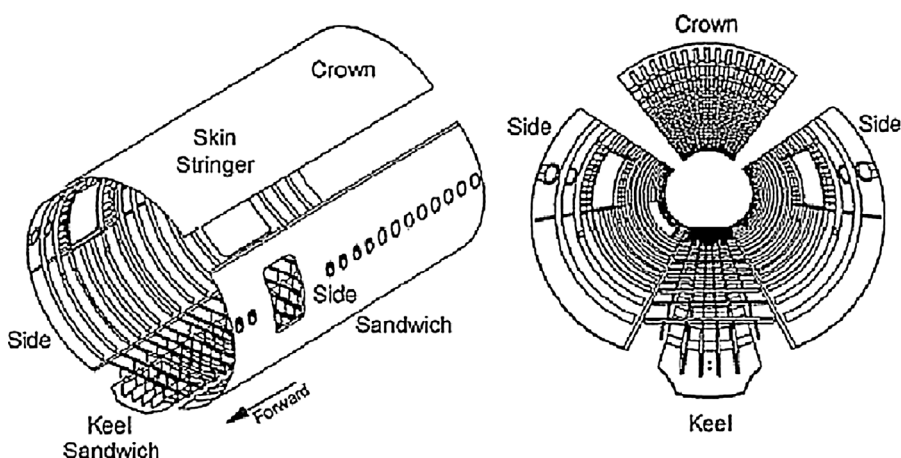

Fig. 23. Transport aircraft wide-body fuselage (Reproduced from [156]).

bank of materials certified by the FAA through an AGATE (Advanced General Aviation Transport Experiments) programme. Other planes of the same kind have probably been developed around the world. In Europe, a research programme called FUBACOMB (FULL BARREL COMPOSITE) took place in the early 2000s and studied a composite sandwich fuselage produced by AFP for business jets [153,154]. The objectives of the programme were:

- To develop fibre placement knowledge and capability in Europe
- To validate innovative concepts for composite fuselage structures with high integration and automatization through fibre placement technology
- To demonstrate affordable, large, complex composite tooling
- To develop in process monitoring and visualization techniques for fibre placement

The result was a fully integrated, full composite sandwich, front fuselage, in particular the canopy (first of its kind in Europe). However, to the best of the authors' knowledge, there has been no practical application of this programme since, unlike Raytheon, some manufacturers believe that greater mass savings are possible with composite wings.

The introduction of sandwich structures for primary structures on large aircraft has not progressed beyond the framework of American research programmes. The ACT (Advanced Composite Technology, [155–158]) programme studied a civil transport aircraft fuselage type in the 1990s. A “four shell concept” structure was studied and, according to the criteria of the time, the result was a skin/stringer configuration for the crown quadrant and a sandwich construction for the keel and side quadrants (see Fig. 23). It should be noted that these studies did not lead

to a practical application; the fuselages of the A350 and B 787 are not in sandwich construction (see Fig. 20). Other studies carried out under the HSR (High Speed Research) programme [158] in the 1990s included a fuselage and a wing of a supersonic civil sandwich aircraft using skins in IM-7/PETI-5. PETI-5 is a NASA-patented polyimide resin.

Sandwich technology and its advantages have finally spread to light aviation with the aircraft manufacturer Elixir Aircraft based in La Rochelle (France), which received EASA CS 23 certification on March 20th, 2020 for its two-seater carbon aircraft called the “Elixir” [159]. The Elixir was developed around sandwich technology applied to the One-Shot production method. This technique consists of designing and manufacturing complex elements (such as a wing) in one part and one operation without complex structural assemblies. The One-Shot technology used here was taken from competitive sailing, where it has been in use for more than 15 years. The development, coupling sandwich technology with One-Shot and the influence of competitive sailing design, has allowed the generalization of monoblock structures in this aircraft (see Fig. 24). Innovative definitions limiting the number of assemblies have been introduced, and break with the traditional “black metal” widely used in aviation composite design. For example, the wing of the Elixir is made without ribs or spars. Traditional mechanical assembly methods, such as screwing, riveting and gluing are eliminated. The complete wing (full span) is entirely in One-Shot and monoblock. The fuselage, canopy arch and control surfaces (ailerons, flaps and vertical stabilizer) are also made in One-Shot. The main advantage of such an approach is the drastic reduction in the number of elements. As a result, the aircraft consists of only 600 parts, against more than 10,000 with conventional light aircraft metallic construction. Fewer parts and fewer assemblies

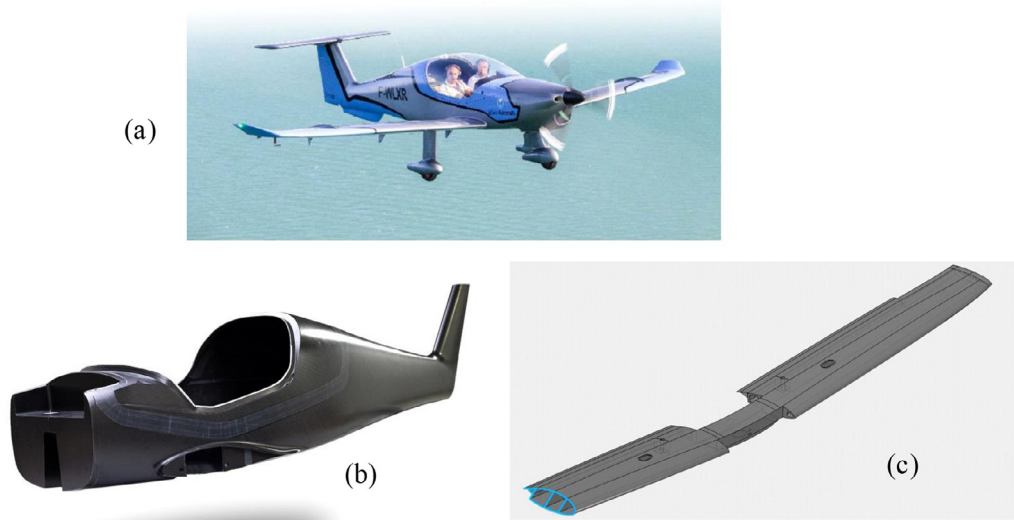

Fig. 24. (a) The "Elixir", (b) One-Shot fuselage, (c) Cross sectional view of the One-Shot wing.

mean fewer potential failures. Thus, safety is enhanced by the simplicity of the structure and performance is improved by the reduced weight. Elixir Aircraft present the Elixir as the One-Shot carbon 4th generation of light aviation, after 1st wood and canvas, 2nd aluminium and rivets, and 3rd composites and aluminium [160].

For the past 25 years, Scaled Composites Inc., led by Burt Rutan, has been involved in the design and fabrication of many all-composite proof-of-concept and competition aircraft. These aircraft, which are made in CFRP/foam sandwich construction, are not included in this report. They include the Voyager, which was the first plane to fly around the world without refuelling, the Pond Racer, the NASA AD-1 oblique wing research aircraft, the scale demonstration T-46, and the Starship [151].

In conclusion, sandwich structures are now well established as primary structures for business aircraft thanks to their excellent cost/reliability/weight ratio. This solution is also starting to spread in general aviation. However, the share of sandwich structures has decreased on the commercial aircraft and stiffened composite solutions are preferred.

6. The case of helicopters

Helicopters must be treated separately because the stresses acting on the fuselages are of the order of a hundred N/mm, whereas they are 10 times higher for business jets and helicopters are not pressurized. On the other hand, the vibratory constraints on the blades, the economic constraints for civil helicopters or the operational constraints for military helicopters led to composite materials being adopted very early, with rates almost at 100% since the 1990s.

The first application was rotor blades made of honeycomb or foam cores with fiberglass skins. For Vosteen et al. [151], the first composite sandwich blades were tested on the XCH-47 by VERTOL in 1959 then, following research programmes, all the 4,130 steel blades of these helicopters had been replaced by composite blades by the mid-1970s. For J. Cinquin [164], the lifespan of a composite helicopter blade is longer than the lifespan of the helicopter. In addition, the possibility of producing optimized aerodynamic shapes (cambered and twisted sections) by moulding makes it possible to increase the take-off weight and reduce fuel consumption. For example, on an AS330, the take-off weight is increased by 400 kg (+ 6%) and the gain in cruising flight by approximately 6%. The use of optimized stacking sequences also allows the frequencies of the blades to be clearly separated. Finally, the saving in manufacturing cost is more than 20% compared to the cost price of the same blade made of metallic material. Therefore, in France, the first

composite blades brought into service in series were on the Gazelle helicopter produced by Aerospatiale (now Airbus Helicopter) whose first flight took place on April 7th, 1967 (see Fig. 25). This technology was then applied to all the following programmes.

As stated in [162], this technology, in combination with STARFLEX-type composite rotors (see [8]) has significantly reduced operating costs (13% for the PUMA helicopter). In addition, composite technologies have also reduced the cost of owning and manufacturing helicopters, opening them up to the civilian market from the 1970s with, in particular, the Ecureuil (first flight on June 27th, 1974), which was designed with automobile techniques to reduce costs and which already incorporated 25% of its mass in composite. Another advantage of these composite blades was their tolerance to damage, which had been emphasized since their introduction in the 1970s. The new designs make it possible to absorb hard projectiles launched at 150 m/s, whether in frontal or razing impact. They are also resistant to the detachment of ice blocks from the fuselage in the event of flights in icing conditions [165–167]. Today, research is moving towards less noisy "Blue Edge" type blades, which have the structural characteristic of having two internal spars [168–170].

The relative proportion of composite has increased rapidly in helicopter structures, with a majority of sandwich structures. The EC 135, brought into service in 1990 already incorporated 50% composite and the EC 155 "Dauphin" brought into service in 1997 had around 60% of its structure in composite. The main part of the structure was in Nomex honeycomb/metallic skin sandwich structures (in yellow, Fig. 26) because this solution is economical and has better vibratory qualities, especially for the tail boom. We can also note that the floor was made of honeycomb with aluminium skins because it is also a more economical solution. The weight saving with a carbon/Nomex honeycomb floor would be 20% but the cost would be increased by 70%. In general, the introduction of sandwich and composite parts into helicopter structures has resulted in weight reductions of 15 to 55% and cost reductions of 30 to 80% [164]. In the latest Airbus Helicopter programme, the entire structure was made of composite materials.

The most innovative composite structure is certainly that of the Tiger combat helicopter (first flight, April 27th, 1991). The Tiger was the first all-composite helicopter developed in Europe. Composite materials are used for 90-95% of its structure [163], a large proportion being in Nomex honeycomb core with carbon skins. This need for lightness is due to operational requirements, in particular great manoeuvrability and a high rate of climb. The Tiger can withstand + 4 / -1g, which makes it one of the rare helicopters to be able to fly loops. The structure

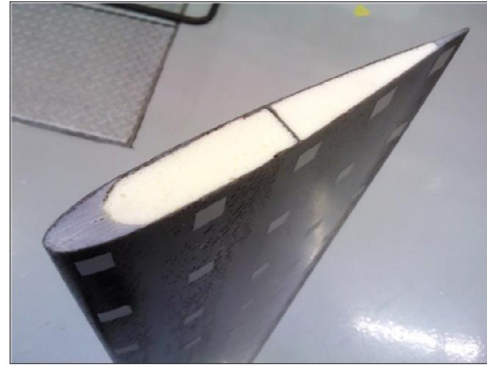
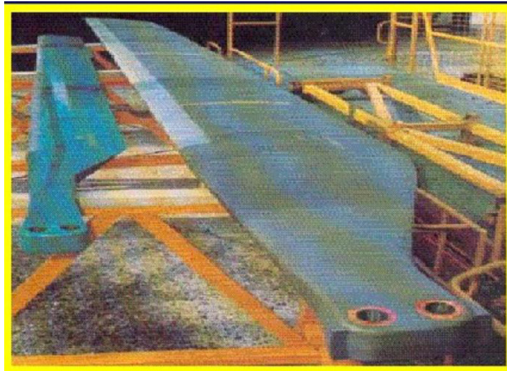

Fig. 25. Left: photo of historical blades (the smaller: Gazelle helicopter, the larger: Puma helicopter), from [161,162]; Right: typical section of a blade manufactured at Institut Clément Ader with a front spar used for impact research [158–160].

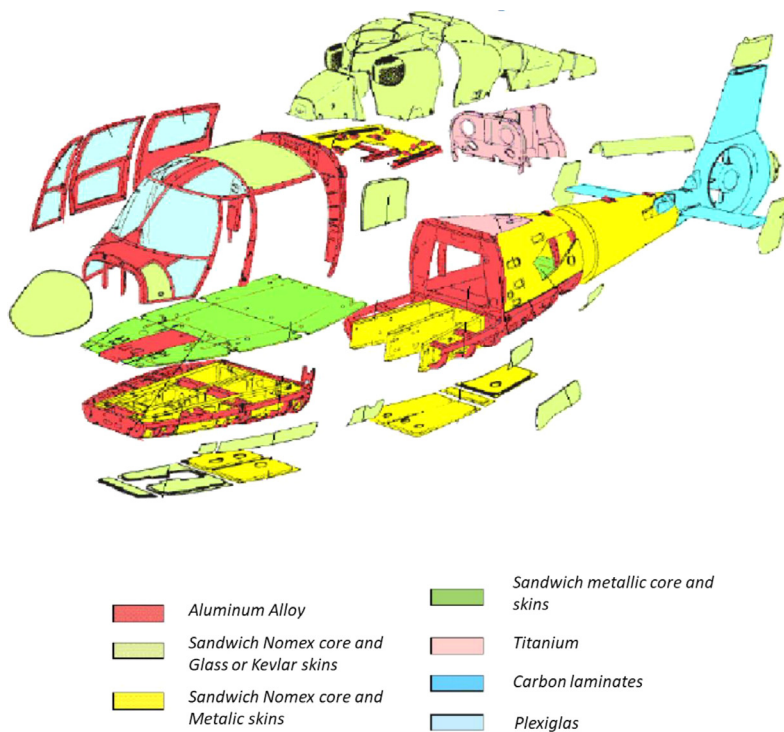

Fig. 26. Structure of the EC 155 "Dauphin", reproduced from [163].

weight /maximum take-off weight ratio is exceptional even if it cannot be given here. The AH-64 Apache helicopter is a reference in this field and the Tiger weighs 40% less [171].

Despite this extreme lightness, the Tiger was certified with fatigue tests on a new structure that had deliberately been given damage (impacts and manufacturing defects) corresponding to several times the service life, then a static test at extreme load was conducted on the same structure and finally a crash test was performed, again on the same structure. In the event of a crash, the helicopter must ensure the survival of the crew, which it has done in operational conditions several times. The crash calculation on composite structures was extremely new in the late 80s and early 90s, yet the challenge was taken up by engineers of the time. Tiger technologies have also been applied to the NH 90 transport helicopter, which has a slightly lower rate of composites [163].

7. Future of aeronautic sandwich structures

Research is mainly focused on structural improvement, the integration of functions and the multifunctionality of sandwich structures. Re-

garding structural improvement, many innovative cores have been developed or rediscovered in recent years. A brief, non-exhaustive review of many sandwich cores can be found in [8]: foams, balsa, cork, plywood, honeycomb, and other shapes, lattice cores (Kagome, tetrahedral, pyramidal or other), corrugated, folded, X-Cor, Hierarchical, Nap Core, Entangled carbon fibres among probable others. Only a few of these possibilities could be interesting to replace Nomex or aluminium honeycombs, which are very efficient. Ullah et al. [172] studied a titanium kagome core that outperformed traditional honeycombs in shear and compression. This solution is proposed for ailerons (see Fig. 27). It also has the advantage of being ventilated, which eliminates the potential problems of moisture ingress. A review of the different possibilities of this type of core, in particular from the multifunctional point of view, was made by Han et al. [176]. Folded cores have also been widely studied in recent years, especially in the VeSCo (Ventable Shear Core, [145,173]) programme. They have the major advantage of being ventilated but they can also be optimized to improve the manufacturing and the skin/core bonding strength [174], see Fig. 27. These origami-type structures offer a wide variety of materials and possible patterns

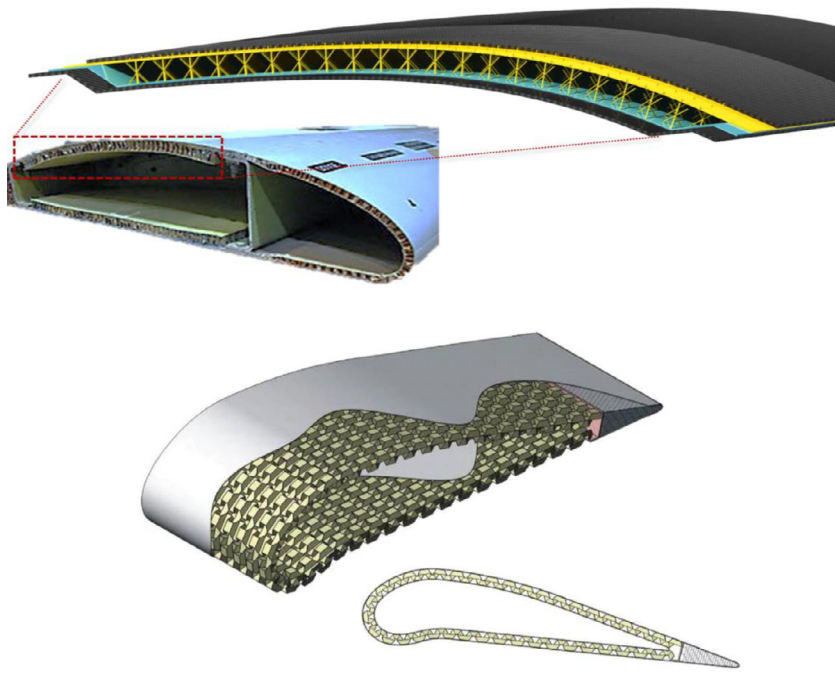

Fig. 27. Top, kagome core for an aileron (reproduced from [172]); bottom, folded core solution (reproduced from [174]).

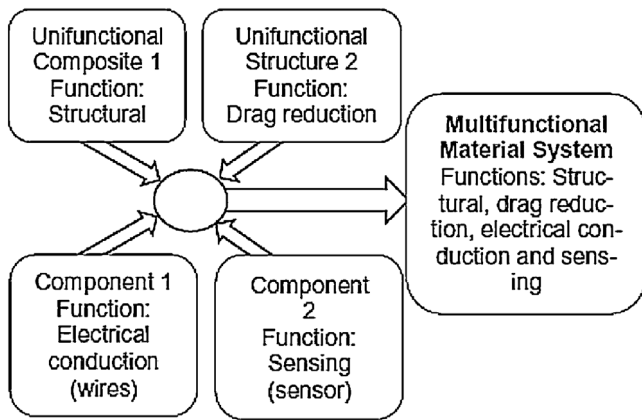

Fig. 28. Definition of a multifunctional material or structure (from [184]).

[175]. They have also been optimized for sound absorption, in nacelles in particular [174,177]. Note that honeycomb cores have long been used as a Helmholtz resonator for sound absorption. However, to date, the folded core has not found applications as far as the authors know, probably due to a mass penalty. NASA X-Cor core has interesting mechanical characteristics but seems to be mainly intended for space applications [178,179]. It is also possible to optimize the damping of a structure by adding very damping core, such as entangled cores, at key locations [180].

It is interesting to recall the definition of a multi-functional structure given by Ferreira et al. [184] (see Fig. 28): “A multifunctional material system should integrate in itself the functions of two or more different components and/or composites/materials/structures increasing the total system’s efficiency”. In this sense, many of the sandwich structures presented in the previous sections are multifunctional in that, generally, they naturally integrate 2 physical functions passively: mechanics + thermal insulation (see Section 3); mechanics + stealth (see Fig. 16); mechanical + moisture ingress, mechanical + acoustic absorption, mechanical + vibration damping. Hermann et al. [145] and Sasche et al.

[173] emphasize another important function that sandwich structures could provide: damage tolerance. Of course, a more resistant core can be used but this solution is often also heavier. Another way is to optimize the design of the core so that it can act as a crack arrestor. This function has been studied for marine structures, for example, in [181–183]. The internal rib of the blade shown in Fig. 25 acts as a damage arrestor in case of high velocity impact [165–167].

In the previous examples, the intrinsic properties of the cores or local designs are used for multiphysical applications limited to the conjunction of two factors rather than being multifunctional in the system sense. There are ultimately few real multifunctional applications where the sandwich is designed a priori to fulfil a wide variety of functions. Rion et al. [17] studied the possibility of using solar cells as working skins for the Solar Impulse project (see Fig. 29 (a)). Smyers [185] presents a drone application of a sandwich whose core is an RF antenna in addition to playing a structural role. Boermans [186] presents a sandwich allowing suction of the boundary layer for a glider (see Fig. 29 (b)). The suction is provided by a pump and the folded sandwich is perforated. It should be noted that, in many other areas, sandwich structures serve as mechanical supports for other functions: energy harvesting [187], heat exchange [188], microwave absorption [189,190], integrated electronic device [192], battery integration [193–195], damping with resonator integration [191], fire protection [196], or (typically Balsa core for naval military structures), crash [197].

As part of the “SUGAR” (for Subsonic Ultra Green Aircraft Research) programme the General Electric, Georgia Tech, Cessna team proposed the concept of “protective skin” shown in Fig. 30 [198]. The solution is an asymmetric sandwich from the functional and mechanical point of view. The inner skin plays the structural role, the core and the outer skin integrate a large number of functions, including: aerodynamic optimization, acoustic and thermal insulation, protection against lightning strikes, moisture insulation, damage protection, and installation of ice protection systems, wires, antennas or other sensors.

In conclusion, a realistic prospect on fuselages is proposed by A. Tropis in [199]: “..., the next generation of fuselages must combine the 2 previous domains (“load carrying structure plus damage tolerance/robustness”) plus a “multifunctional capability” i.e. electrical conductivity,... In conclusion, to define a fully optimized fuselage, multi functional materials must be

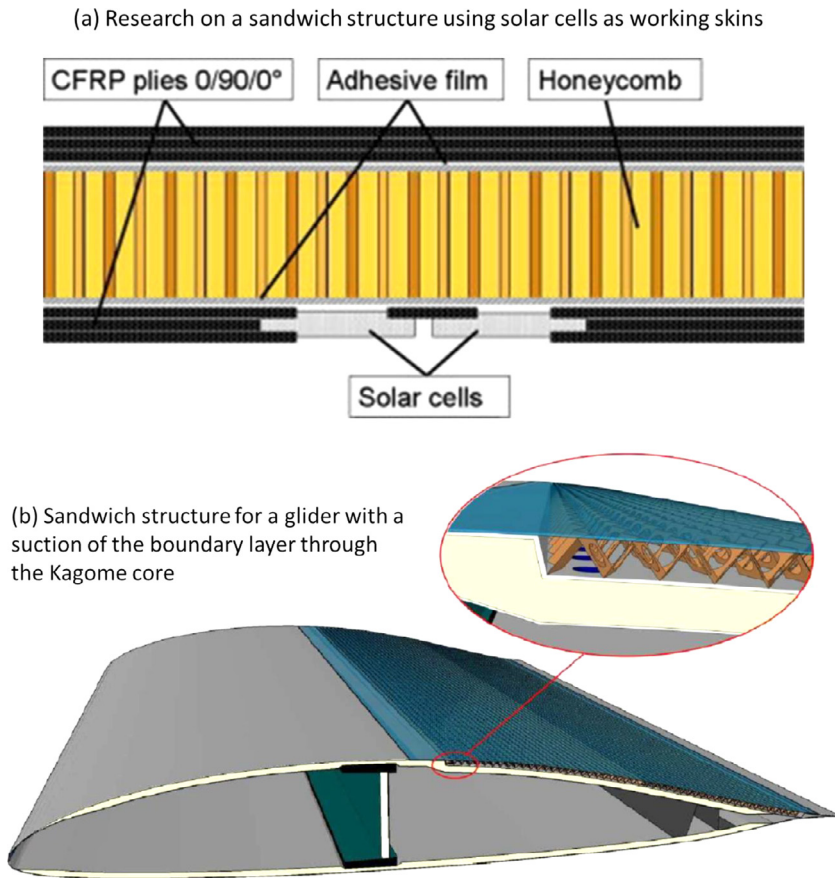

Fig. 29. Two examples of multifunctional sandwich structures (a) from [17] and (b) from [186].

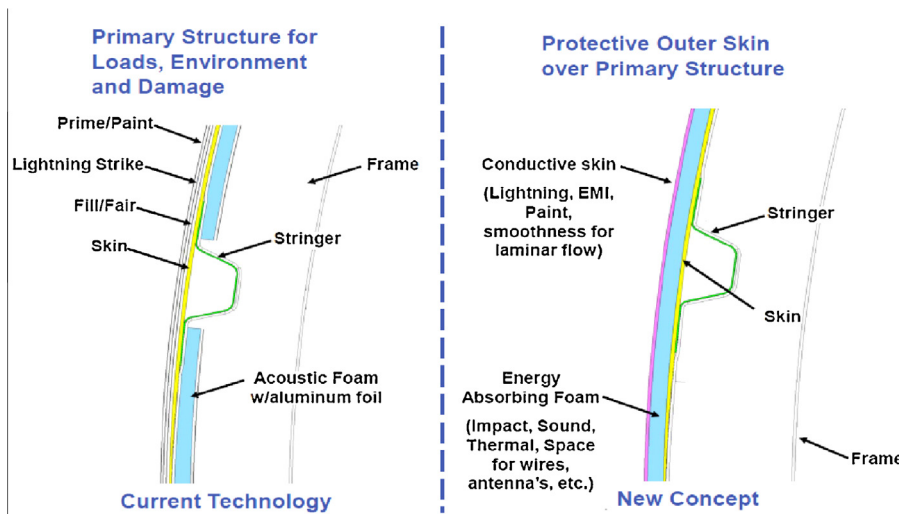

Fig. 30. GE/Georgia Tech/ Cessna Protective skin concept in the SUGAR Programme (from [198]).

further developed combined with improved damage tolerance/large damage capabilities properties. It will be the challenge of the next decade”.

8. Conclusions

From the 1920s and Theodore Von Karman’s patent, up to the present day, sandwich structures have been present in aeronautics for almost 100 years. Despite their undeniable qualities, their complexity from a mechanical point of view, together with the challenges of manufacturing and control, slowed down their introduction, which was done in a careful, gradual manner. The difficulties encountered in certain programmes allowed engineers to learn a lot and then bounce back successfully with

new applications. Today, sandwich structures, mainly with composite skins and Nomex honeycombs, dominate light helicopter structures and have some applications in business jets without being generalized. Despite the difficulties of certifying a sandwich structure, small innovative companies, such as Elixir Aircraft, produce all-sandwich passenger aircraft in One-Shot. In contrast their use is tending to decrease in single- or double-aisle civil aircraft, where it is limited to some secondary structures and commercial equipment.

The design of a sandwich composite structure is part of the general difficulty of designing composite structures detailed in the GAP (acronym of Geometry, Architecture, Process) method [8]. In particular, the choice, not only of materials but also of architectures, is very

vast and no real methodology has been established. However, this “hyperchoice of materials and architectures” can prove to be an advantage in the integration of functions, which will be the future of composite aeronautical structures. Beyond multi-physical solutions, sandwich structures could enable a real integration of systems to be achieved, as is beginning to be analysed in the space domain [200] and proposed in the SUGAR programme. This will require adaptation of the industrial organization. The launch of new research programmes can provide and experience this new paradigm and encourage learning and dialogue between specialists in systems and structures.

Declaration of Competing Interest

The authors declare that they have no known competing financial interests or personal relationships that could have appeared to influence the work reported in this paper.

Acknowledgements

This paper is a result of 25 years of experience in the field of aeronautic composite structures at the Institut Clement Ader, Toulouse, and strong relationships with the Aircraft Industry. The first author wishes to thank more specially his former advisors during his PhD with Eurocopter: Jean-Pierre Jaouen (Now retired) and Alain Crouzet (now Daher). The authors also thank their PhD students who have contributed to the knowledge of sandwich structures: Jaime Rivera (Fuerza Aera de Chile), Yulfian Aminanda (now Universiti Teknologi Brunei), Phacharaporn Bunyawanichakul (Kasetsart University, Thailand), Laurent Mezeix (Burapha University, Thailand), John Susainsathan (University of Nebrija, Spain) and Juan de Dios Rodriguez Ramirez. Special thanks to J. Leibacher (Webmaster of Soaring Magazine archive and professor at the University of Tucson) and Nicolas Mahuet (Head of engineering of Elixir Aircraft) for their help.

References

- [1] N.J. Hoff, S.E. Mautner, Sandwich construction, *Aeronaut. Eng. Rev.* 3 (1944) 1–7.
- [2] H.G. Allen, *Analysis and Design of Structural Sandwich Panels*. Pergamon Press, Oxford 1969
- [3] F.G. Plantema, *Sandwich Construction*, John Wiley & Sons, New-York, 1966.
- [4] D. Zenkert, *The Handbook of Sandwich Construction*. E-MAS Publishing, London 1997
- [5] C. Kassapoglou, *Design and Analysis of Composite Structures (with application to aerospace structures)*, Wiley, Chichester UK, 2010.
- [6] L.A. Carlsson, G.A. Kardomateas, *Structural and Failure Mechanics of Sandwich Composites*, Springer, Dordrecht, NL, 2011.
- [7] D. Gay, *Composite Materials Design and Applications*, CRC press, Boca Raton FL, 2015.
- [8] F. Neveu, B. Castanié, P. Olivier, The GAP methodology: A new way to design composite structure *Mater. Des.* 172, 107755, doi:<https://doi.org/10.1016/j.matdes.2019.107755>.
- [9] D. Guedra-Degeorges, P. Thevenet, S. Maisson, *Damage Tolerance of Aeronautical Sandwich Structures*, in: A. Vautrin (Ed.), *Mechanics of Sandwich Structures*, Kluwer Academic Publisher, 1998, pp. 29–36.
- [10] J. Tomblin, T. Lacy, B. Smith, S. Hooper, A. Vizzini, S. Lee, Review of damage tolerance for composite sandwich airframe structures, FAA Report DOT/FAA/AR-99/49, 1999.
- [11] B. Castanié, J.-J. Barrau, J.-P. Jaouen, Theoretical and experimental analysis of asymmetric sandwich structures, *Comp. Struct.* 55 (2002) 295–306, doi:[10.1016/S0263-8223\(01\)00156-8](https://doi.org/10.1016/S0263-8223(01)00156-8).
- [12] B. Castanié, J.-J. Barrau, J.-P. Jaouen, S. Rivallant, Combined shear/compression structural testing of asymmetric sandwich structures, *Exp. Mech* 44 (2004) 461–472, doi:[10.1007/BF02427957](https://doi.org/10.1007/BF02427957).
- [13] B. Castanié, Contribution à l'étude des structures sandwichs dissymétriques, PhD Supaéro 2000. <http://oatao.univ-toulouse.fr/4282/>.
- [14] J. Zhang, Q. Qin, X. Han, W. Ai, The initial plastic failure of fully clamped geometrical asymmetric metal foam core sandwich beams, *Comp. Part B* 87 (2016) 233–244, doi:[10.1016/j.compositesb.2015.10.027](https://doi.org/10.1016/j.compositesb.2015.10.027).
- [15] J. Deng, A. Peng, W. Chen, G. Zhou, X. Wang, On stability and damage behavior of asymmetric sandwich panels under uniaxial compression, *J. Sandwich Struct. Mater.* On line (Feb 2020), doi:[10.1177/1099636220905778](https://doi.org/10.1177/1099636220905778).
- [16] A. Fink, C. Einzmann, Discrete tailored asymmetric sandwich structures, *Comp. Struct.* 238 (2020) 111990, doi:[10.1016/j.compstruct.2020.111990](https://doi.org/10.1016/j.compstruct.2020.111990).
- [17] J. Rion, Y. Leterrier, J.-A.E. Manson, J.-M. Blairon, Ultra-light asymmetric photovoltaic sandwich structures, *Comp. Part A* 40 (2009) 1167–1173, doi:[10.1016/j.compositesa.2009.05.015](https://doi.org/10.1016/j.compositesa.2009.05.015).
- [18] K.E. Evans, The design of doubly curved sandwich panels with honeycomb core, *Comp. Struct.* 17 (1991) 95–111, doi:[10.1016/0263-8223\(91\)90064-6](https://doi.org/10.1016/0263-8223(91)90064-6).
- [19] S. Smidt, Bending of curved sandwich beams, a numerical approach, *Comp. Struct.* 34 (1996) 279–290, doi:[10.1016/0263-8223\(95\)00149-2](https://doi.org/10.1016/0263-8223(95)00149-2).
- [20] O.T. Thomsen, J.R. Vinson, Conceptual design principles for non-circular pressurized sandwich fuselage sections – a design study based on a high-order sandwich theory formulation, *J. Comp. Mater.* 36 (2002) 313–345, doi:[10.1177/0021998302036003468](https://doi.org/10.1177/0021998302036003468).
- [21] N.J. Hoff, S.E. Mautner, The buckling of sandwich type model, *J. Aeronaut. Sci.* 12 (July 1945), doi:[10.2514/8.11246](https://doi.org/10.2514/8.11246).
- [22] L. Fagerberg, D. Zenkert, Imperfection-induced wrinkling material failure in sandwich panels, *J. Sand. Struct. Mat.* 7 (2005) 195–219, doi:[10.1177/1099636205048526](https://doi.org/10.1177/1099636205048526).
- [23] E.E. Gdoutos, I.M. Daniel, K.A. Wang, Compression facing wrinkling of composite sandwich structures, *Mech. Mater.* 35 (2003) 511–522, doi:[10.1016/S0167-6636\(02\)00267-3](https://doi.org/10.1016/S0167-6636(02)00267-3).
- [24] L. Fagerberg, D. Zenkert, Effects of Anisotropy and Multi-axial Loading on the Wrinkling of Sandwich Panels, *J. Sand. Struct. Mater.* 7 (2005) 177–194, doi:[10.1177/109963205048525](https://doi.org/10.1177/109963205048525).
- [25] B.K. Hadi, F.L. Matthews, Development of Benson-Mayers theory on the wrinkling of anisotropic sandwich panels, *Comp. Struct.* 49 (2000) 425–434, doi:[10.1016/S0263-8223\(00\)00077-5](https://doi.org/10.1016/S0263-8223(00)00077-5).
- [26] R. Vescovini, M. D'Ottavio, L. Dozio, O. Polit, Buckling and wrinkling of anisotropic sandwich plates *International, J.Eng. Sci.* 130 (2018) 136–156, doi:[10.1016/j.ijengsci.2018.05.010](https://doi.org/10.1016/j.ijengsci.2018.05.010).
- [27] K. Niu, R. Talreja, Modeling of wrinkling in sandwich panels under compression, *J. Eng. Mech.* 125 (1999) 875–883, doi:[10.1061/\(ASCE\)0733-9399\(1999\)125:8\(875\)](https://doi.org/10.1061/(ASCE)0733-9399(1999)125:8(875)).
- [28] K. Yu, H. Hu, S. Chen, S. Belouettar, M. Potier-Ferry, Multi-scale techniques to analyze instabilities in sandwich structures, *Comp. Struct.* 96 (2013) 751–762, doi:[10.1016/j.compstruct.2012.10.007](https://doi.org/10.1016/j.compstruct.2012.10.007).
- [29] M.A. Douville, P. Le Grogne, Exact analytical solutions for the local and global buckling of sandwich beam-columns under various loadings, *Int. J. Sol. Struct.* 50 (2013) 2597–2609, doi:[10.1016/j.ijsolstr.2013.04.013](https://doi.org/10.1016/j.ijsolstr.2013.04.013).
- [30] L. Léotoing, S. Drapier, A. Vautrin, Nonlinear interaction of geometrical and material properties in sandwich beam instabilities, *Int. J. Sol. Struct.* 39 (2002) 3717–3739, doi:[10.1016/S0020-7683\(02\)00181-6](https://doi.org/10.1016/S0020-7683(02)00181-6).
- [31] J. Bertolini, B. Castanié, J.J. Barrau, J.P. Navarro, C. Petiot, Multi-level experimental and numerical analysis of composite stiffener debonding, Part 2: Element and panel level, *Comp. Struct.* 90 (2009) 392–403, doi:[10.1016/j.compstruct.2009.04.002](https://doi.org/10.1016/j.compstruct.2009.04.002).
- [32] S. Zhang, J.M. Dulieu-Barton, O.T. Thomsen, The effect of temperature on the failure modes of polymer foam cored sandwich structures, *Comp. Struct.* 121 (2015) 104–113, doi:[10.1016/j.compstruct.2014.10.032](https://doi.org/10.1016/j.compstruct.2014.10.032).
- [33] B. Castanié, J.-F. Ferrero, Nonlinear response of symmetric sandwich structures subjected to in-plane loads, in: *Proceedings of the 10th International Conference on Sandwich Structures ICSS*, Nantes, France, 2012, pp. 27–29. August 2012.
- [34] B. Castanié, J.-J. Barrau, J.-F. Ferrero, J.-P. Jaouen, Analyse non linéaire et structurale des poutres sandwichs dissymétriques, *Revue des Composites et des Matériaux Avancés* 10 (2000).
- [35] P. Minguet, J. Dugundji, P.A. Lagace, Bucking and failure of sandwich plates with graphite-Epoxy face and various core, in: *Proceedings of the 28th AIAA/ASME/ASCE/AHS Structures, Structural Dynamics and Materials Conference*, 6–8 April 1987 Paper AIAA-87-07, doi:[10.2514/3.45573](https://doi.org/10.2514/3.45573).
- [36] A. Tropis, M. Thomas, J.L. Bounie, P. Lafon, Certification of the composite outer wing of the ATR72, *J. Aerospace Eng. Proc. Inst. Mech. Eng. Part G* 209 (1994) 327–339. doi:[10.1243/PIME_PROC_1995_209_307_02](https://doi.org/10.1243/PIME_PROC_1995_209_307_02).
- [37] J. Rouchon, Certification of Large Aircraft Composite Structures, in: *Proceedings of the 17th ICAS, Recent Progress and New Trends in Compliance Philosophy*, Stockholm, Sweden, 1990.
- [38] E. Morteau, C. Fualdes. Composites @ Airbus, damage tolerance methodology. FAA Work-shop for Composite Damage Tolerance and Maintenance, Chicago IL, 2006. <https://www.niar.wichita.edu/niarworkshops/Portals/0/Airbus%20Composites%20-%20Damage%20Tolerance%20Methodology%20-%20Fualdes.pdf?ver=2007-05-31-095449-530> Accessed 05/26/2020
- [39] J.B. Chang, V.K. Goyal, J.C. Klug, J.I. Rome, Composite Structures Damage Tolerance Analysis Methodologies. NASA/CR-2012-217347
- [40] T.D. McQuigg. Compression After Impact Experiments and Analysis on Honeycomb Core Sandwich Panels with Thin Facesheets. NASA/CR-2011-217157.
- [41] J.S Tomblin, K.S. Raju, J. Liew, B.L Smith. Impact Damage Characterization Damage Tolerance of Composite Sandwich Airframe Structures. FAA Report DOT/FAA/AR-00/44, 2000.
- [42] J.S Tomblin, K.S. Raju, J.F. Acosta, B.L. Smith, N.A. Romine, Impact Damage Characterization And Damage Tolerance Of Composite Sandwich Airframe Structures-phase II. FAA Report DOT/FAA/AR-02/80, 2002.
- [43] J.S Tomblin, K.S. Raju, G. ArosteGuy. Damage Resistance and Tolerance of Composite Sand-wich Panels—scaling Effects. FAA Report DOT/FAA/AR-03/75, 2003.
- [44] Serge Abrate, Bruno Castanié, DS Yapa, Rajapakse, Dynamic failure of composite and sandwich structures, Springer, Dordrecht NL, 2012.
- [45] S. Heimbs, Virtual testing of sandwich core structures using dynamic finite element simulations, *Comput Mater Sci* 45 (2009) 205–216, doi:[10.1016/j.commatsci.2008.09.017](https://doi.org/10.1016/j.commatsci.2008.09.017).
- [46] Y. Aminanda, B. Castanié, J.-J. Barrau, P. Thevenet, Experimental analysis and modeling of the crushing of honeycomb cores, *App. Comp. Mat.* 12 (2005) 213–217, doi:[10.1007/s10443-005-1125-3](https://doi.org/10.1007/s10443-005-1125-3).

- [47] L. Liu, H. Wang, Z. Guan, Experimental and numerical study on the mechanical response of Nomex honeycomb core under transverse loading, *Comp. Struct.* 121 (2015) 304–314, doi:10.1016/j.compstruct.2014.11.03.
- [48] B. Castanié, C. Bouvet, Y. Aminanda, J.-J. Barrau, P. Thevenet, Modelling of low energy/low velocity impact on nomex honeycomb sandwich structures with metallic skins, *Int. J. Imp. Eng.* 35 (2008) 620–634, doi:10.1016/j.ijimpeng.2007.02.008.
- [49] C. Audibert, A.-S. Andréani, E. Lainé, J.-C. Grandidier, Discrete modelling of low-velocity impact on Nomex® honeycomb sandwich structures with CFRP skins, *Comp. Struct.* 207 (2019) 108–118, doi:10.1016/j.compstruct.2018.09.047.
- [50] Y. Aminanda, B. Castanié, J.-J. Barrau, P. Thevenet, Experimental and numerical study of compression after impact of sandwich structures with metallic skins, *Comp. Sci. Tech.* 69 (2009) 50–59, doi:10.1016/j.compstruct.2007.10.045.
- [51] T.E. Lacy, Y. Hwang, Numerical modeling of impact-damaged sandwich composites subjected to compression-after-impact loading, *Comp. Struct.* 61 (2003) 115–128, doi:10.1016/S0263-8223(03)00034-5.
- [52] B. Castanié, Y. Aminanda, C. Bouvet, J.-J. Barrau, Core crush criteria to determine the strength of sandwich composite structures subjected to compression after impact, *Comp. Struct.* 86 (2008) 243–250, doi:10.1016/j.compstruct.2008.03.032.
- [53] Z. Xie, A.J. Vizzini, A feasible methodology for engineering applications in damage tolerance of composite sandwich structures, *J. Comp. Mater* 38 (2004) 891–914, doi:10.1177/2F0021998304042476.
- [54] R. Aitken, *Damage due to soft body impact on composite sandwich aircraft panels* PhD Thesis, University of Auckland, Department of Mechanical Engineering, 2000.
- [55] S. Guo, R. Morishima, Numerical analysis and experiment of composite sandwich T-joints subjected to pulling load, *Comp. Struct.* 94 (2011) 229–238, doi:10.1016/j.compstruct.2011.06.022.
- [56] P. Sheahan, L. Betsuch, T. Holcombe, B. Baron, *Robust composite sandwich structures*. AIAA/ASME/ASCE/AHS/ASC Structures, Structural Dynamics and Materials Conference, in: Proceedings of the 1998 39th AIAA/ASME/ASCE/AHS/ASC Structures, Structural Dynamics, and Materials Conference and Exhibit and AIAA/ASME/AHS Adaptive Structures Forum. Part 1 (of 4), 3, Long Beach, CA, USA, 1998, pp. 2228–2238. 20–23 April 1998.
- [57] J. Feldhusen, C. Warkotsch, A. Kempf, Development of a mechanical technology for joining sandwich elements, *J. Sand. Struct. Mat.* 11 (2009) 471–486, doi:10.1177/1099636209105378.
- [58] U.V.R.S. Turaga, C.T. Sun, *Failure Modes and Load Transfer in Sandwich T-Joints*, *J. Sand. Struct. Mater.* 2 (2000) 225–245 10.1177/109963620000200304.
- [59] Frank J. Filippi, Boris Levenetz, Optimum Joint Design for High-Temperature Honeycomb Panels, *SAE Trans.* 68 (1960) 658–664 www.jstor.org/stable/44565172 JSTORAccessed 19 Apr. 2020.
- [60] S. Heimbs, M. Pein, Failure behaviour of honeycomb sandwich corner joints and inserts, *Comp. Struct* 89 (2009) 575–588, doi:10.1016/j.compstruct.2008.11.013.
- [61] B.J. Kim, D.G. Lee, Development of a satellite structure with the sandwich T-joint, *Comp. Struct.* 92 (2010) 460–468, doi:10.1016/j.compstruct.2009.08.030.
- [62] E. Bozhevolnaya, A. Lyckegaard, Local effects at core junctions of sandwich structures under different types of loads, *Comp. Struct.* 73 (2006) 24–32, doi:10.1016/j.compstruct.2005.01.031.
- [63] S.S. Vel, V. Caccese, H. Zhao, Elastic coupling effects in tapered sandwich panels with laminated anisotropic composite facings, *J. Comp. Mater.* 39 (2005) 2161–2183, doi:10.1177/0021998305052033.
- [64] O.T. Thomsen, J.R. Vinson, Modeling of tapered sandwich panels using a high-order sandwich theory formulation, *AIAA J* 40 (2002) 1867–1875, doi:10.2514/2.1866.
- [65] S.K. Kuczma, A.J. Vizzini, Failure of sandwich to laminate tapered composite structures, *AIAA J* 37 (1999) 227–231, doi:10.2514/2.694.
- [66] C. Gin-Boay, S. Leong-Keey, C. Lee-Soon, Stress distribution in sandwich beams under tension, *Comp. Struct.* 45 (1999) 195–204, doi:10.1016/S0263-8223(99)00026-4.
- [67] J.D. Stromsoe, Modeling of in-plane crushed honeycomb cores with applications to rampdown sandwich structure closures. Thesis Faculty of San Diego State University 2011
- [68] J. Rivera Candia. Theoretical and experimental study of the tapered zone in asymmetrical sandwich structures. PhD Academia Politecnica Aeronautica, Santiago de Chile, November 2003.
- [69] ESA PSS-03-1202 Insert Design Handbook, European Space Agency, Noordwijk, The Netherlands.
- [70] MIL-HDBK-23A Structural Sandwich Composites, Department of Defense USA, 1974.
- [71] W.G. Youngquist, E.W. Kuenzi, Stresses Included in a Sandwich Panel by Load Applied at an Insert, Forest Products Laboratory, Report No. 1845, Madison 5, Wisconsin, 1955.
- [72] O.T. Thomsen, Sandwich plates with ‘through-the-thickness’ and ‘fully potted’ inserts: evaluation of differences in structural performance, *Comp. Struct.* 40 (1997) 159–174, doi:10.1016/S0263-8223(98)00017-8.
- [73] J. Wolff, M. Brysch, C. Hühne, Validity check of an analytical dimensioning approach for potted insert load introductions in honeycomb sandwich panels, *Comp. Struct.* 202 (2018) 1195–1215, doi:10.1016/j.compstruct.2018.05.105.
- [74] G. Qi, L. Ma, S.-Y. Wang, Modeling and reliability of insert in composite pyramidal lattice truss core sandwich panels, *Comp. Struct.* 221 (2019) 110888, doi:10.1016/j.compstruct.2019.04.060.
- [75] P. Bunyawanichakul, B. Castanie, J.J. Barrau, Experimental and numerical analysis of inserts in sandwich structures, *Appl. Comp. Mater.* 12 (2005) 177–191, doi:10.1007/s10443-005-1122-6.
- [76] P. Bunyawanichakul, B. Castanié, J.J. Barrau, Non-linear finite element analysis of inserts in composite sandwich structures, *Comp. Part B* 39 (2008) 1077–1092, doi:10.1016/j.compositesb.2008.05.004.
- [77] J.D.D. Rodriguez-Ramirez, B. Castanie, C. Bouvet, Experimental and numerical analysis of the shear nonlinear behaviour of Nomex honeycomb core: application to insert sizing, *Comp. Struct.* 193 (2018) 121–139, doi:10.1016/j.compstruct.2018.03.076.
- [78] N. Raghu, M. Battley, T. Southward, Strength variability of inserts in sandwich panels, *J. Sand. Struct. Mater.* 11 (2009) 501–517, doi:10.1177/1099636209104524.
- [79] S. Slimane, S. Kebdani, A. Boudjemai, A. Slimane, Effect of position of tension-loaded inserts on honeycomb panels used for space applications, *Int. J. Interact. Des. Manuf.* 12 (2018) 393–408, doi:10.1007/s12008-017-0383-2.
- [80] J.D.D. Rodríguez-Ramírez, B. Castanié, C. Bouvet, On the potting failure of inserts for sandwich panels: Review of defects and experimental analysis, *Mech. Adv. Mat. Struct.* On line, doi:10.1080/15376494.2020.1724352.
- [81] R. Seemann, D. Krause, Numerical modelling of partially potted inserts in honeycomb sandwich panels under pull-out loading, *Comp. Struct.* 203 (2018) 101–109, doi:10.1016/j.compstruct.2018.07.028.
- [82] J.D.D. Rodriguez-Ramirez, B. Castanie, C. Bouvet, Damage mechanics modelling of the shear nonlinear behavior of Nomex honeycomb core. Application to sandwich beams, *Mech. Adv. Mater. Struct.* 27 (2020) 80–89, doi:10.1080/15376494.2018.1472351.
- [83] J.D.D. Rodriguez-Ramirez, B. Castanie, C. Bouvet, Insert of sandwich panels sizing through a failure mode map, *Comp. Struct.* 234 (2020) 111724, doi:10.1016/j.compstruct.2019.111724.
- [84] L. Mezeix, S. Dols, C. Bouvet, B. Castanié, J.P. Giavarini, N. Hongkarnjanakul, Experimental analysis of impact and post-impact behaviour of inserts in Carbon sandwich structures, *J. Sand. Struct. Mat.* 21 (2019) 135–153, doi:10.1177/1099636216687582.
- [85] H.M. Hsiao, S.M. Lee, R.A. Buyny, Core crush problem in manufacturing of composite sandwich structures: mechanisms and solutions, *AIAA J.* 44 (2006) 901–907, doi:10.2514/1.18067.
- [86] K.F. Karlsson, B.T. Astrom, Manufacturing and applications of structural sandwich components, *Comp. Part A* 28 (1997) 97–111, doi:10.1016/S1359-835X(96)00098-X.
- [87] D.A. Crump, J.M. Dulieu-Barton, J. Savage, The manufacturing procedure for aerospace secondary sandwich structure panels, *J. Sand. Struct. Mat.* 12 (2010) 421–447, doi:10.1177/1099636209104531.
- [88] J. Kratz, P. Hubert, Vacuum bag only co-bonding prepreg skins to aramid honeycomb core. Part I. Model and material properties for core pressure during processing, *Comp. Part A* 72 (2015) 228–238, doi:10.1016/j.compositesa.2014.11.026.
- [89] J. Kratz, P. Hubert, Vacuum-bag-only co-bonding prepreg skins to aramid honeycomb core. Part II. In-situ core pressure response using embedded sensors, *Composites: Part A* 72 (2015) 219–227, doi:10.1016/j.compositesa.2014.11.030.
- [90] S.S. Tavares, N. Caillet-Bois, V. Michaud, J.A.E. Månson, Non-autoclave processing of honeycomb sandwich structures: Skin through thickness air permeability during cure, *Comp. Part A* 41 (2010) 646–652, doi:10.1016/j.compositesa.2010.01.013.
- [91] S.S. Tavares, V. Michaud, J.A.E. Månson, Assessment of semi-impregnated fabrics in honeycomb sandwich structures, *Comp. Part A* 41 (2010) 8–15, doi:10.1016/j.compositesa.2009.09.005.
- [92] S. Sequeira Tavares, Y. Roulin, V. Michaud, J.A.E. Månson, Hybrid processing of thick skins for honeycomb sandwich structures, *Comp. Sci. Tech.* 71 (2011) 183–189, doi:10.1016/j.compstruct.2010.11.001.
- [93] M. Anders, D. Zebrine, T. Centea, S.R. Nutt, Process diagnostics for co-cure of sandwich structures using in situ visualization, *Comp. Part A* 116 (2019) 24–35, doi:10.1016/j.compositesa.2018.09.029.
- [94] L. Moretti, B. Castanié, G. Bernhart, P. Olivier. Characterization and modelling of cure-dependent properties and strains during composites manufacturing. *J. Comp. Mater.* On line, doi:10.1177/0021998320912470.
- [95] L. Mezeix, A. Seman, M.N.M. Nasir, Y. Aminanda, A. Rivai, B. Castanié, P. Olivier, K.M. Ali, Spring-back simulation of unidirectional carbon/epoxy flat laminate composite manufactured through autoclave process, *Comp. Struct.* 124 (2015) 196–205, doi:10.1016/j.compstruct.2015.01.005.
- [96] M. Fiorina, A. Seman, B. Castanié, K.M. Ali, C. Schwob, L. Mezeix, Spring-in prediction for carbon/epoxy aerospace composite structure, *Comp. Struct.* 168 (2017) 739–745, doi:10.1016/j.compstruct.2017.02.074.
- [97] G. Fernlund, Spring-in of angled sandwich panels, *Comp. Sci. Tech.* 65 (2005) 317–323, doi:10.1016/j.compstruct.2004.08.001.
- [98] E. Kappel, Spring-in of curved CFRP/foam-core sandwich structures, *Comp. Struct.* 128 (2015) 155–164, doi:10.1016/j.compstruct.2015.03.058.
- [99] E. Kappel, Spring-in of angled sandwich panels, *Comp. Sci. Tech.* 65 (2005) 317–323, doi:10.1016/j.compstruct.2004.08.001.
- [100] Y. Mahadik, K. Potter, Experimental investigation into the thermoelastic spring-in of curved sandwich panels, *Comp. Part A* 49 (2013) 68–80, doi:10.1016/j.compositesa.2013.02.006.
- [101] R. Benton Heslehurst, *Defects and Damage in Composite Materials and Structures*, CRC Press Taylor & Francis Group, Boca Raton, FL USA, 2014.
- [102] M.E. Ibrahim, Nondestructive evaluation of thick-section composites and sandwich structures: a review, *Comp. Part A* 64 (2014) 36–48, doi:10.1016/j.compositesa.2014.04.010.
- [103] J.S. Tomblin, L. Salah, J.M. Welch, M.D. Borgman - Final Report, DOT/FAA/AR-03/74, 2004
- [104] US Military Handbook 17-3F. Composite materials handbook volume 3. Polymer matrix composites materials usage, design, and analysis. US Department of Defense 2002
- [105] <http://www.flight-mechanic.com/composite-honeycomb-sandwich-repairs/>, accessed 22/04/2020
- [106] C. Duong, C.H. Wang, *Composite Repairs, Theory and Design*, Elsevier, Amsterdam, 2007.

- [107] R. Benton Heslehurst, *Engineered Repairs of Composite Structures*, CRC Press Taylor & Francis Group, Boca Raton, FL USA, 2019.
- [108] K. Katnam, L.D. Silva, T. Young, Bonded repair of composite aircraft structures: a review of scientific challenges and opportunities, *Progr Aerosp Sci* 61 (2013) 26–42, doi:10.1016/j.paerosci.2013.03.003.
- [109] O. Balci, O. Çoban, M. Özgür Bora, E. Akagündüz, E. Bülent Yalçın, Experimental investigation of single and repeated impacts for repaired honeycomb sandwich structures, *Mat. Sci. Eng.: A* 682 (2017) 23–30, doi:10.1016/j.msea.2016.11.030.
- [110] H. Park, C. Kong, A study on low velocity impact damage evaluation and re-pair technique of small aircraft composite structure, *Comp. Part A* 42 (2011) 1179–1188, doi:10.1016/j.compositesa.2011.05.002.
- [111] C.H. Wang, A.J. Gunnion, Optimum shapes of scarf repairs, *Comp. Part A* 40 (2009) 1407–1418, doi:10.1016/j.compositesa.2009.02.009.
- [112] A.B. Harman, C.H. Wang, Improved design methods for scarf repairs to highly strained composite aircraft structure, *Comp. Struct.* 75 (2006) 132–144, doi:10.1016/j.compstruct.2006.04.091.
- [113] F. Campbell, The case against honeycomb core, 49th international society for the advancement of manufacturing and process engineering (SAMPE) symposium, Long Beach, CA (May 2004).
- [114] J.H. Fogarty, Honeycomb core and myth of moisture ingress, *Appl Comp. Mat.* 17 (2010) 293–307, doi:10.1007/s10443-009-9121-7.
- [115] W.C. Jackson, T.K. O'Brien, Water Intrusion in Thin-Skinned Composite Honeycomb Sandwich Structures, *J. Am. Helicopter Soc.* 35 (1990) 31–37, doi:10.4050/JAHS.35.31.
- [116] D.M. Cise, R.S. Lakes, Moisture ingress in honeycomb core sandwich panels: directional aspects, *J. Comp. Mat.* 31 (1997) 2249–2263, doi:10.1177/002199839703102202.
- [117] E. Kececi, R. Asmatulu, Effects of moisture ingressions on mechanical properties of honeycomb-structured fiber composites for aerospace applications, *Int. J. Adv. Manuf. Technol.* 88 (2017) 459–470, doi:10.1007/s00170-016-8744-8.
- [118] M.E. Tuttle, Moisture diffusion in honeycomb core sandwich composites. ICCM-17 Edinburgh, Scotland, July 27–31, 2009.
- [119] H.G. Allen, Panneaux et volumes obtenus par construction sandwich: Evolution et développement, *Mat. Tech.* 77 (1989) 11–18, doi:10.1051/mattech/198977060011.
- [120] Hugo Junkers, Abdeckung für Flugzeugtragflächen und dergleichen, DE310040, 1915
- [121] Von Karman TH and Stock, P. British Patent No 235 884 June 21, 1924
- [122] N.J. Hoff, A short history of the development of airplane structures, *Am. Sci.* 34 (1946) 370–388 www.jstor.org/stable/27826109 JSTOR Accessed 22 Apr. 2020.
- [123] N.J. Hoff with S.E. Mautner. Sandwich construction in gliders, *Soaring magazine*, September–October, 1944
- [124] A.J. Kinloch, Norman Adrian De Bruyne. 8 November 1904–7 March 1997. *Biographical Memoirs of Fellows of the Royal Society*, vol. 46, 2000, pp. 127–143. JSTOR, www.jstor.org/stable/770392 Accessed 19 Apr. 2020.
- [125] GIFAS (Groupement des industries Aéronautiques Française): L'industrie aéronautique et spatiale française 1907-1982, tome I: 1907-1947 Anthologie des deux ouvrages de 1934 et 1949.
- [126] J.P. Susainathan, F. Eyma, E. De Luycker, A. Cantarel, B. Castanié, Manufacturing and quasi-static bending behavior of wood-based sandwich structures, *Comp. Struct.* 182 (2017) 487–504, doi:10.1016/j.compstruct.2017.09.034.
- [127] J.P. Susainathan, F. Eyma, E. De Luycker, A. Cantarel, C. Bouvet, B. Castanié, Experimental investigation of compression and compression after impact of wood-based sandwich structures, *Comp. Struct.* 220 (2019) 236–249, doi:10.1016/j.compstruct.2019.03.095.
- [128] https://www.airforce.gov.au/sites/default/files/minisite/static/7522/RAAFmuseum/exhibitions/restoration/dh_98.htm, accessed 25 April 2020.
- [129] E. Paroissien, M. Sartor, J. Huet, F. Lachaud, Analytical two-dimensional model of a hybrid (bolted/bonded) single-lap joint, *J. Aircraft* 44 (2007) 573–582, doi:10.2514/1.24452.
- [130] E. Paroissien, F. Lachaud, On the Potential Static Strength of Hybrid (Bolted/Bonded) Lap Joints with Functionally Graded Adhesives, *AIAA J.* 57 (2019) 4093–4103, doi:10.2514/1.J058372.
- [131] L.M. Smith, C.W. Rogers, Bonded Bomber B-58, *SAE Trans* 70 (1962) 477–486 JSTOR www.jstor.org/stable/44469505. Accessed 26 Apr. 2020.
- [132] J. Hamer, Honeycomb structure and its application to the Concorde rudder, *Composites* 2 (1971) 242–245, doi:10.1016/0010-4361(71)90153-4.
- [133] J.C. Joanides, et al., Mach 3 wing structures stiffened skin versus sandwich, *SAE Trans.* 69 (1961) 167–178 JSTOR www.jstor.org/stable/44553914. Accessed 19 Apr. 2020.
- [134] W.A. Spivak, XB-70A Mach 3 Design and Operating Experience, *SAE Trans.* 75 (1967) 114–126 JSTOR www.jstor.org/stable/44564841. Accessed 19 Apr. 2020.
- [135] D.B. Rogerson, Technological advancements resulting from XB-70 performance requirements, *SAE Trans.* 74 (1966) 604–625 JSTOR www.jstor.org/stable/44554241. Accessed 19 Apr. 2020.
- [136] <https://www.avionslegendaires.net/avion-militaire/north-american-xb-70- Valkyrie/> accessed 27/05/2020
- [137] D.R. Jenkins, T.R. Landis, VALKYRIE, North American Mach 3 superbomber, Speciality Press, 2004 North Branch, MN 55026, USA.
- [138] R.A. Davis, S.D. Elrod, D.T. Lovell. Titanium honeycomb structure. <https://ntrs.nasa.gov/search.jsp?R=19740022813>
- [139] P.W. Merlin, Mach 3 Legend Design and Development of the Lockheed Blackbird. <https://ntrs.nasa.gov/search.jsp?R=20120013451>
- [140] Peter W. Merlin, Design and development of the blackbird: challenges and lessons learned. Proceedings of the 47th AIAA Aerospace Sciences Meeting Including The New Horizons Forum and Aerospace Exposition 5 - 8 January 2009, Orlando, Florida
- [141] S. Pace. Lockheed SR-71 blackbird. Crowood Edition 2004, Marlborough, Wiltshire SN8 2HR, Great Britain.
- [142] W.G. Roeseler, B. Sarh, M.U. Kismarton. Composite structures: the first 100 years. ICCM 16 Kyoto, Japan 2007.
- [143] K.B. Armstrong, D.W. Stevens, J. Alet, 25-years of use of Nomex Honeycomb in floor panels and sandwich structures. Proceedings of the 50-Years of Advanced Materials or Back to the Future, SAMPE Conference, Toulouse 1994 from June 06 to June 10, pp 17–39.
- [144] J. PORA. Composite Materials in the Airbus A380. From History to Future - ICCM-13 Beijing, China, June 25–29, 2001.
- [145] A.S. Herrmann, P.C. Zahlen, I. Zuardy. Sandwich structures technology in commercial aviation, Present Applications and Future Trends. In O.T. Thomsen et al. (eds), *Sandwich Structures 7: Advancing with Sandwich Structures and Materials*, 13–26.
- [146] L.F. Vosteen, R.N. Hadcock. Composite chronicles: a study of the lessons learned in the development, Production, and Service of composite structures, NASA Contractor Report 4620, 1994
- [147] D. Chaumette, Flight qualification of composite structures At AMD-BA, in: *Proceedings of the 23rd Structures, Structural Dynamics and Materials Conference, New Orleans, LA, U.S., 10 May 1982 - 12 May 1982*.
- [148] Mr. Geoffrey Allen Wardle. My aircraft design, Structures And Manufacturing Research And Development Core Career Overview. <https://fr.slideshare.net/GeoffreyWardleMScMSc/my-full-core-career-presentation-latest-159781260> accessed 28/04/2020.
- [149] E.H. Hooper, Starship: A model for future design, *Materiaux et Tech.* 77 (1989) 23–30, doi:10.1051/mattech/198977060023.
- [150] <https://www.bobscherer.com/Pages/Starship.html> Accessed May 4th 2020.
- [151] L.F. Vosteen, R.N. Hadcock. Composite chronicles: a study of the lessons learned in the development, production, and service of composite structures. NASA Contract Report 4620. November 1994.
- [152] K. Retz, The road to large scale composite application on wide body commercial transports, *SAE Trans.* 112 (2003) 270–280 www.jstor.org/stable/44699201 JSTOR Accessed 29 Apr. 2020.
- [153] <https://www.yumpu.com/en/document/read/38943740/findings-of-the-fubacom-project-and-links-to-new-developments> - Accessed 06 May 2020
- [154] <https://www.azom.com/article.aspx?ArticleID=2916> Accessed 06 May 2020
- [155] D.M. McGowan, D.R. Ambur, Compression response of a sandwich fuselage keel panel with and without damage, NASA Technical Memorandum 110302, 1997.
- [156] T.H. Walker, P.J. Minguet, B.W. Flynn, D.J. Carbery, G.D. Swanson, L.B. Ilcewicz, Advanced technology composite fuselage- structural performance, NASA CR 4732 (1997).
- [157] D.R. Tenney, J.G. Davis Jr., R. Byron Pipes, N. Johnston, NASA composite materials development: lessons learned and future challenges, NATO AVT 164 (Fall 2009) (found on NTRS, Accessed 2017-10-12).
- [158] D.R. Tenney, J.G. Davis Jr., N. Johnston, R. Byron Pipes, J.F. McGuire. Structural framework for flight: nasa's role in development of advanced composite materials for aircraft and space structures. NASA/CR-2011-217076.
- [159] JEC Composite magazine article "Elixir Aircraft receives EASA CS-23 certification" 1 apr 2020: <http://www.jeccomposites.com/knowledge/international-composites-news/elixir-aircraft-receives-easa-cs-23-certification>
- [160] <https://elixir-aircraft.com/en/> Accessed May 11th, 2020
- [161] M. Robert. Les composites aéronautiques: 40 ans déjà et ce n'est que le début !!! Colloque Composite de TOULOUSE du 3 octobre 2007.
- [162] Aérospatiale. *Materiaux composites: dans la grande mutation des structures*. DCT 1135, Avril 1986.
- [163] J. Cinquin. Utilisation des matériaux composites à matrice organique en aéronautique. Les avantages, les points durs. *Vision du futur. Entretiens de l'AMAC*. ENS Cachan. 19 Mars 2013
- [164] J. Cinquin. Les composites en aérospatiale. *Techniques de l'Ingénieur*.
- [165] Edited by F. Pascal, P. Navarro, S. Marguet, J.-F. Ferrero. Study of medium velocity impacts on the lower surface of helicopter blades, in: Valentina Lopresto, Antonio Langella, Serge Abrate (Eds.), *Dynamic Response and Failure of Composite Materials and Structures*, Woodhead Publishing, 2017, pp. 159–181, doi:10.1016/B978-0-08-100887-4.00005-6. Edited by.
- [166] F. Pascal, A. Rogani, B. Mahmoud, P. Navarro, S. Marguet, J.-F. Ferrero, Impact damage prediction in thin woven composite laminates – Part II: Application to normal and oblique impacts on sandwich structure, *Comp. Struct.* 190 (2018) 43–51, doi:10.1016/j.compstruct.2018.02.013.
- [167] I. Tawk, J. Aubry, P. Navarro, J.-F. Ferrero, S. Marguet, S. Rivallant, S. Lemaire, P. Rauch, Study of impact on helicopter blade, *Eng. Fail. Anal.* 24 (2012) 38–45, doi:10.1016/j.engfailanal.2012.03.005.
- [168] P. Rauch, M. Gervais, P. Cranga, A. Baud, J. Hirsch, A. Walter, P. Beaumier, Blue edge: The design, development and testing of a new blade concept, in: *Proceedings of the 67th Annual Forum of the American Helicopter Society, American Helicopter Soc. International Fairfax, VA, 2011*, pp. 542–555.
- [169] P. Beaumier, B. Van Der Wall, K. Pengel, C. Kessler, M. Gervais, Y. Delrieux, J.-F. Hirsch, P. Crozier, From erato basic research to the blue edge rotor blade: an example of virtual engineering? in: *Proceedings of the Rotorcraft Virtual Engineering Conference, Liverpool, 8–10 Nov. 2016*.
- [170] M. Filippi, E. Zappino, E. Carrera, B. Castanié, Effective static and dynamic finite element modeling of a double swept composite rotor blade. *J. Am. Hel. Soc.* On line doi:10.4050/JAHS.65.032003.
- [171] S. Brosselin, Eurocopter Tiger's advanced technology: a comparison with the Longbow Apache, *Vertiflite* 41 (1995) 18–22.

- [172] I. Ullah, J. Elambasseril, M. Brandt, S. Feih, Performance of bio-inspired Kagome truss core structures under compression, *Comp. Struct.* 118 (2014) 294–302, doi:10.1016/j.compstruct.2014.07.036.
- [173] R. Sachse, D. Fernandez, Y. Klett, P. Middendorf. Integral, disruptive, and multifunctional aircraft structures, in S. Pantelakis, K. Tserpes (eds.), *Revolutionizing Aircraft Materials and Processes*, Springer Nature Switzerland AG 2020, doi:10.1007/978-3-030-35346-9_7.
- [174] L. Komarnitskiy, *L'étude des structures pliables ainsi que la préparation des essais statiques et dynamiques sur celles-ci* Master thesis report, Toulouse, University Paul sabatier, 2006.
- [175] S. Heimbs, Foldcore, Sandwich structures and their impact performance: an overview, in: S. Abrate, B. Castanié, Y. Rajapakse (Eds.), *Dynamic Failure of Composite and Sandwich Structures. Solid Mechanics and Its Applications*, 192, Springer, Dordrecht, 2013, doi:10.1007/978-94-007-5329-7_11.
- [176] B. Han, Z.-J. Zhang, Q.-C. Zhang, Q. Zhang, T.J. Lub, B.-H. Lua, Recent advances in hybrid lattice-cored sandwiches for enhanced multifunctional performance, *Ext. Mech. Let.* 10 (2017) 58–69, doi:10.1016/j.eml.2016.11.009.
- [177] <https://cct-kai.com/en/eng-and-services/folded-structures/acoustic-folded-core> Accessed 12 May 2020
- [178] T.K. O'Brien, I.L. Paris, Exploratory investigation of failure mechanisms in transition regions between solid laminates and X-cor truss sandwich, *Comp. Struct.* 57 (2002) 189–204, doi:10.1016/S0263-8223(02)00083-1.
- [179] T.M. Krivanek, B.C. Yount, *Composite payload fairing structural architecture assessment and selection*, SAMPE Conference, May 2012.
- [180] A. Shahdin, L. Mezeix, C. Bouvet, J. Morlier, Y. Gourinat, Fabrication and mechanical testing of glass fiber entangled sandwich beams: a comparison with honeycomb and foam sandwich beams, *Comp. Struct.* 90 (2009) 404–412, doi:10.1016/j.compstruct.2009.04.003.
- [181] J.L. Grenestedt, Development of a new peel-stopper for sandwich structures, *Comp. Sci. Tech.* 61 (2001) 1555–1559, doi:10.1016/S0266-3538(01)00052-5.
- [182] J. Jakobsen, E. Bozhevolnaya, O.T. Thomsen, New peel stopper concept for sandwich structures, *Comp. Sci. Tech.* 67 (2007) 3378–3385, doi:10.1016/j.compscitech.2007.03.033.
- [183] J. Jakobsen, O.T. Thomsen, J.H. Andreasen, E. Bozhevolnaya, Crack deflection analyses of different peel stopper design for sandwich structure, *Comp. Sci. Tech.* 69 (2009) 870–875, doi:10.1016/j.compscitech.2008.01.021.
- [184] A.D.B.L. Ferreira, P.R.O. Nóvoa, A. Torres Marques, Multifunctional material systems: a state-of-the-art review, *Comp. Struct.* 151 (2016) 3–35, doi:10.1016/j.compstruct.2016.01.028.
- [185] B. Smyers, W. Baron, J. Marshall. Structural-electric characterization of a load bearing antenna RF laminate. *Proceedings of the COMPTTEST 2008 Conference*, Dayton OH, October 20–22.
- [186] L. Boermans, *Research on sailplane aerodynamics at delft university of technology. Recent and present developments*, in: *Proceedings of the Netherlands Association of Aeronautical Engineers (NVvL)*, 2006.
- [187] Y.-W. Zhang, C. Su, Z.-Y. Ni, J. Zang, L.-Q. Chen, A multifunctional lattice sandwich structure with energy harvesting and nonlinear vibration control, *Comp. Struct.* 221 (2019) 110875, doi:10.1016/j.compstruct.2019.04.047.
- [188] D.T. Queheillalt, G. Carbajal, G.P. Peterson, H.N.G. Wadley, A multifunctional heat pipe sandwich panel structure, *Int. J. Heat Mass Trans.* 51 (2008) 312–326, doi:10.1016/j.ijheatmasstransfer.2007.03.051.
- [189] C. Wang, M. Chen, H. Lei, Z. Zeng, K. Yao, X. Yuan, D. Fang, Frequency-selective-surface based sandwich structure for both effective load bearing and customizable microwave absorption, *Comp. Struct.* 235 (2020) 111792, doi:10.1016/j.compstruct.2019.111792.
- [190] P. Bollen, N. Quiévy, C. Bailly, I. Huynen, T. Pardoën, *Multifunctional sandwich structure for electromagnetic absorption and mechanical performances*, in: *Proceedings of the 16th European Conference on Composite Materials, ECCM, 2014*.
- [191] H. Chen, X.P. Li, Y.Y. Chen, G.L. Huang, Wave propagation and absorption of sandwich beams containing interior dissipative multi-resonators, *Ultrasonics* 76 (2017) 99–108, doi:10.1016/j.ultras.2016.12.014.
- [192] R. Kothari, C.T. Sun, Design and analysis of multifunctional structures with embedded electronics for thermomechanical loads, *J. Sand. Struct. Mat.* 14 (2012) 734–752, doi:10.1177/1099636212460541.
- [193] Y. Zhang, J. Ma, A.K. Singh, L. Cao, J. Seo, C.D. Rahn, C.E. Bakis, M.A. Hickner, Multi-functional structural lithium-ion battery for electric vehicles, *J. Int. Mat. Syst. Struct.* 28 (2017) 1603–1613, doi:10.1177/1045389X16679021.
- [194] L. Zhang, S. Lu, X. Wang, K. Ma, H. Liu, L. Zhou, Manufacture and mechanical properties of sandwich structure-battery composites, *J. Polym. Eng.* 39 (2019) 838–843, doi:10.1515/polyeng-2019-0143.
- [195] J.P. Thomas, S.M. Qidwai, W.R. Pogue, G.T. Pham, Multifunctional structure-battery composites for marine systems, *J. Comp. Mat.* 47 (2013) 5–26, doi:10.1177/0021998312460262.
- [196] C. Wang, M. Chen, K. Yao, X. Zhu, D. Fang, Fire protection design for composite lattice sandwich structure, *Sci.Eng. Comp. Mat.* 24 (2017) 919–927, doi:10.1515/secm-2015-0525.
- [197] A.F. Johnson, Ch.M. Kindervater, K.E. Jackson, Multifunctional design concepts for energy absorbing composite fuselage sub-structures, *Annual Forum Proceedings(1997) - American Helicopter Society*, 2, pp. 1115–1128.
- [198] M.M. D'Angelo, J. Gallman, V. Johnson, E. Garcia, J. Tai, R. Young. N+3 Small Commercial Efficient and Quiet Transportation for Year 2030-2035. NASA/CR–2010-216691
- [199] A. Tropis. *Composite Structure: Evolution & Future Challenges* in *Proceedings of the Workshop on New Modelling Strategies of Damage and Failure of Composite Structures: A Breakthrough in Composite Sizing?* June 30th - July 1st 2014 in Toulouse, France.
- [200] M. Schubert, S. Peretto, A. Dafnis, D. Mayer, H. Atzrodt, *Development and design of mul-tifunctional lightweight structures for satellite applications*, in: *Proceedings of the International Astronautical Congress, IAC, 2018-October*.