



HAL
open science

On the complexity of Independent Dominating Set with Obligations in graphs

Christian Laforest, Timothée Martinod

► **To cite this version:**

Christian Laforest, Timothée Martinod. On the complexity of Independent Dominating Set with Obligations in graphs. [Research Report] LIMOS (UMR CNRS 6158), université Clermont Auvergne, France. 2020. hal-02946979v2

HAL Id: hal-02946979

<https://hal.science/hal-02946979v2>

Submitted on 9 Jan 2021

HAL is a multi-disciplinary open access archive for the deposit and dissemination of scientific research documents, whether they are published or not. The documents may come from teaching and research institutions in France or abroad, or from public or private research centers.

L'archive ouverte pluridisciplinaire **HAL**, est destinée au dépôt et à la diffusion de documents scientifiques de niveau recherche, publiés ou non, émanant des établissements d'enseignement et de recherche français ou étrangers, des laboratoires publics ou privés.

On the complexity of Independent Dominating Set with Obligations in graphs

Christian Laforest, Timothée Martinod¹

Laboratoire d'Informatique, de Modélisation et d'Optimisation des Systèmes, Université Clermont Auvergne, CNRS UMR 6158, 63178 Aubière, FRANCE

Abstract

A subset $D \subseteq V$ is an *independent* (or *stable*) *dominating set* of a graph $G = (V, E)$ if D is an independent set (no edges between vertices of D) and dominates all the vertices of G (each vertex of $V - D$ has a neighbour in D). In this paper we study a generalisation of this classical notion. Namely, an instance of our problem is a graph $G = (V, E)$ and $\Pi = (V_1, \dots, V_k)$ a partition of V . Each subset V_i of Π is called an *obligation*. An *Independent Dominating set with Obligation (IDO)* D in an instance (G, Π) is an independent dominating set of G with the additional property that if a vertex u of obligation V_i is in D , then *all* the others vertices of V_i must also be in D ; i.e., for all $i = 1, \dots, k$, either $V_i \cap D = \emptyset$ or $V_i \subseteq D$ (we say that D *respects* the obligations). Note that when each obligation of Π is a singleton, an *IDO* is just an independent dominating set of G that can be constructed with a greedy algorithm. Among other things, we show that determining if an instance $(G = (V, E), \Pi)$ has an *IDO* is *NP*-complete, even if G is a path (each vertex of G exactly has two neighbours, except two extremities that have one), all the obligations are independent sets of G and they all have the same constant size $\lambda > 1$. We also show that the problem is also *NP*-complete, even if Π is composed of $\sqrt{|V|}$ independent obligations each of size $\sqrt{|V|}$ or if the diameter of G is three. Our results clearly show that this problem is very difficult, even in extremely restricted instances. Hence, in a second part of the paper, we relax the condition to dominate all the vertices of G . However, we show that determining if $(G = (V, E), \Pi)$ contains an independent set D respecting the obligations and dominating at least $3\sqrt{|V|} - 2$ vertices of G is *NP*-complete, even if G is a collection of disjoint paths and obligations are all independent sets of G . On the positive side, we propose a greedy algorithm constructing a solution dominating at least $2\sqrt{|V|} - 1$ vertices in any instance $(G = (V, E), \Pi)$ if all obligations of Π are independent sets of G .

This work was sponsored by a public grant overseen by the French National Research Agency as part of the "Investissements d'Avenir" through the IMobS3 Laboratory of Excellence (ANR-10-LABX-0016) and the IDEX-ISITE initiative CAP 20-25 (ANR-16-IDEX-0001).

¹Corresponding author

Email addresses: christian.laforest@uca.fr (Christian Laforest), timothee.martinod@uca.fr (Timothée Martinod)

1 Introduction

Let $G = (V, E)$ be an undirected graph, with V its set of *vertices* and E its set of *edges*. Let $D \subseteq V$ be a subset of vertices. Set D is a *stable set* or *independent set* of G if G contains no edge between vertices of D . Set D is a *dominating set* of G if each vertex of $V - D$ has at least one neighbour in D . Set D is an *independent dominating set* of G if D is an independent set and a dominating set of G .

There are many variants of domination problems according to the additional properties that are considered, namely the independent dominating set, the total dominating set, the connected dominating set, among others (see [9] and [8]). These problems are central in graph theory. They are also useful and can be used in distributed applications where the goal is to install services or devices on some machines/vertices such that every vertex is neighbour of at least one vertex having the device.

It is well-known that any graph contains at least an independent dominating set. From an algorithmic point-of-view, given a graph $G = (V, E)$ and an integer k , determining if G contains an independent dominating set of size at most k is NP-complete (see [7]). The complexity of the best known exact algorithm to construct a minimum size dominating set is $O(1.4969^{|V|})$, with a measure and conquer approach (see [17]). The problem of independent dominating set was first formalized by Berge [2] and Ore [16] in 1962 and 1965. Garey has shown that finding the smallest independent dominating set of a graph is NP-complete [7]. Independent dominating set has been studied in the literature in the last decades. In 1991 Irving [10] has shown that, unless $P = NP$, no polynomial-time approximation algorithm for this problem can guarantee to find a minimum size independent dominating set within a factor of K , where $K > 1$ is any fixed constant, even in bipartite graphs. In 2004 Chlebík and Chlebíková [3] have shown that it is NP-hard to approximate the minimum size of an independent dominating set in a graph of maximal degree three within a $1 + 1/390$ ratio even in bipartite graphs. In 2020 Akbari et al. [1] have provided a family of connected cubic graphs of n vertices where the minimum size of an independent dominating set is $3n/8$.

In this paper, we study the independent dominating set problem with additional constraints. In our version, an instance contains a graph $G = (V, E)$ and a partition $\Pi = (V_1, \dots, V_k)$ of the set V of vertices of G (i.e. $V_i \subseteq V$ for all $i = 1, \dots, k$, $V_i \cap V_j = \emptyset$ for all $i \neq j$ and $\cup_{i=1}^k V_i = V$). Each subset V_i of Π is called an *obligation* in our paper. Now, given any instance $(G = (V, E), \Pi = (V_1, \dots, V_k))$, an *independent dominating set with obligation (IDO)* D is an independent dominating set of G , *respecting the obligations* of Π , that is: for all $i = 1, \dots, k$, either $V_i \subseteq D$ or $V_i \cap D = \emptyset$. Note that when all the obligations are singletons, any IDO is just an independent dominating set of G .

An obligation can represent a subset of devices that must be used together, not individually, or a team of people that must all be present to make an action. Obligations were recently introduced in [5] for many graph problems such as vertex cover, connected vertex cover, dominating set, total dominating set, independent dominating set, spanning tree, matching and hamiltonian path. The authors mainly obtained hardness results. Studying classical graph problems with additional constraints is not new. The introduction of obligations as an object of study was motivated by considering a sort of “reverse” constraint of *conflicts*. They have been studied during the last years. The general context of conflict constraint is the following. Given a graph $G = (V, E)$, we add a set of pairs of elements of G (vertices or edges) that *cannot* both be in a same solution (that can be a path, a tree, a dominating set, etc. depending of the goal). At the opposite of obligations, a conflict models the fact that two elements of a system cannot be used simultaneously, for example because they are incompatible. Most problems with conflicts are hard, even if the underlying classical version is polynomial. See for example the following recent publications on the subject: [4, 6, 11, 12, 13, 14, 15].

If all the obligations of Π have the same size λ , we say that they are *balanced* or λ -*balanced*. If an obligation $V_i \in \Pi$ is an independent set of G , it is called *stable* (or *independent*). Note that if an obligation is not stable, it cannot be part of an *IDO*; if all the obligations are not stable then (G, Π) does not contain any *IDO*. Hence, in our generalisation, some instances may not contain any *IDO*. For that reason we mainly focus our attention on instances where obligations are all independent.

***IDO* Problem:**

Instance: (G, Π) where $G = (V, E)$ is an undirected graph and $\Pi = V_1, \dots, V_k$ a partition of V .

Question: Does (G, Π) contain an *IDO*?

The *IDO* problem was first introduced by Cornet and Laforest in [5]. They proved its *NP*-completeness even with obligations of maximal size two. However, they used non-stable obligations for the reduction. Because of the previously made remark, it is legitimate to investigate the problem with instances composed of only stable obligations.

In this paper we improve the knowledge of this problem. We prove that the *IDO* problem is *NP*-complete in different cases according to the topology of the graph, the stability and the balance of the obligations. In the whole paper a *path* is a connected graph in which each vertex has exactly two neighbours, except two extremities that have only one. A graph is a *collection of disjoint paths* if it is only composed of paths that are pairwise vertex-disjoint (it is a forest of paths). Thus a path is a very simple structured connected graph with low degree. It has the properties of being a tree, being bipartite and planar. Most algorithmic problems are trivial or easy to solve in paths. However, we show in Section 2 (Theorem 3) that the *IDO* problem is *NP*-Complete, even if G is a path and all the obligations are independent and λ -balanced for any constant $\lambda \geq 2$ (N.B. if the obligations are 1-balanced, the *IDO* problem is polynomial). The reduction involves many intermediate constructions that are presented step by step and illustrated by several figures. We also show in Theorem 4 that even if the graph has diameter three the *IDO* problem remains *NP*-complete.

As mentioned previously, even if the size of obligations is constant the problem is *NP*-complete. Thus we turn our attention on non-constant ones in Section 3. However, we show in Theorem 5 that the *IDO* problem is *NP*-complete even in instances $(G = (V, E), \Pi)$ where obligations are independent and $\sqrt{|V|}$ -balanced. Still in Section 3 we prove several other *NP*-completeness results with other types of comparisons between the sizes and the number of obligations.

Due to all these hardness results, in Section 4 we relax the constraint of dominating *all* the vertices of the graph. To do that we introduce a maximisation version. We called this the *Partially Independent Dominating set with Obligation (PIDO)* problem. We show that deciding if an instance $(G = (V, E), \Pi)$ contains an independent set D of $G = (V, E)$, respecting the obligations of Π and dominating at least $3\sqrt{|V|} - 2$ vertices of G is *NP*-complete, even if G is a collection of disjoint paths and obligations are all independent. On the positive side, we propose a polynomial time algorithm constructing a solution in any instance $(G = (V, E), \Pi)$, dominating at least $2\sqrt{|V|} - 1$ vertices if obligations are all independent. In Section 5 we conclude this paper.

As many results in this paper are obtained by a reduction from the *NP*-complete *Restricted Exact Cover by 3-Sets problem* (see [7]) we describe it here. Let \mathcal{X} be a finite set of elements and \mathcal{C} a collection of triplets (sets of three elements) of \mathcal{X} . Each element of \mathcal{X} appears in exactly three subsets of \mathcal{C} ; thus there are $3q$ elements and $3q$ triplets. Given such an instance $(\mathcal{X}, \mathcal{C})$ it is *NP*-complete to decide if there is a sub-collection $\mathcal{C}' \subseteq \mathcal{C}$ such that each element of \mathcal{X} occurs in exactly one triplet of \mathcal{C}' . Note that if it exists, such a sub-collection \mathcal{C}' has exactly q disjoint triplets.

2 *IDO* in a path

In this section, we show that the *IDO* problem is *NP*-complete even in a path with stable and λ -balanced obligations for any constant $\lambda \geq 2$. As said above, we will do a reduction from the *RX3C* problem. Since the construction uses several gadgets, we will proceed step by step. First, each element in *RX3C* is in exactly three triplets. To represent membership of the elements and the intersection between triplets, we will create one gadget per element.

Construction 1. *Let $(\mathcal{X}, \mathcal{C})$ be an instance of *RX3C* where $\mathcal{X} = \{x_1, \dots, x_{3q}\}$ and $\mathcal{C} = \{c_1, \dots, c_{3q}\}$. For each element $x_i \in \mathcal{X}$ we construct an associated gadget composed of a graph and some obligations.*

- *Let $c_j, c_k, c_l \in \mathcal{C}$ with $j < k < l$ be the three triplets containing x_i .*
- *We add 16 obligations denoted $y_i^T, y_i^F, y_i^1, \dots, y_i^{11}, x_i^1, x_i^2$ and x_i^3 each composed of two independent vertices. In each obligation y and x we consider one left vertex and one right vertex respectively denoted by $L(y)$ and $R(y)$ or $L(x)$ and $R(x)$.*

- We add the vertices Z_j, Z_k and Z_l that are vertices of gadgets (defined later) representing the triplets containing element x_i .
- We add the edges $(R(y_i^T)L(y_i^F)), (R(y_i^F)L(y_i^1)), (R(y_i^F)L(y_i^2)), (L(y_i^1)R(y_i^4)), (R(y_i^1)L(y_i^4)), (R(y_i^1)R(y_i^2)), (L(y_i^2)L(y_i^3)), (R(y_i^3)L(y_i^5)), (R(y_i^3)L(y_i^6)), (R(y_i^4)L(y_i^9)), (L(y_i^5)R(y_i^7)), (R(y_i^5)R(y_i^6)), (R(y_i^5)L(y_i^7)), (L(y_i^6)R(y_i^8)), (R(y_i^6)L(y_i^8)), (R(y_i^7)L(y_i^{10})), (R(y_i^8)L(y_i^{11})), (R(y_i^9)L(x_i^1)), (R(y_i^{10})L(x_i^2)), (R(y_i^{11})L(x_i^3)), (R(x_i^1)Z_j), (R(x_i^2)Z_k)$ and $(R(x_i^3)Z_l)$.

Note that the gadget associated to each element x_i is composed of a graph that is a collection of disjoint paths, and 16 stable 2-balanced (if we exclude the Z -vertices) obligations. The aggregation of these $3q$ gadgets has $48q$ obligations. See an illustration in Figure 1. Six vertices are represented differently for clarity purposes. The green squares and the orange polygons are the interface vertices of the link between triplets and their three elements. Each gadget of element is composed of the obligation y, x and the subgraph induced by their vertices. Each gadget of element is connected to exactly three gadgets of triplet (defined later, see an illustration in Figure 2). This representation will also appear in Figure 2 and Figure 3.

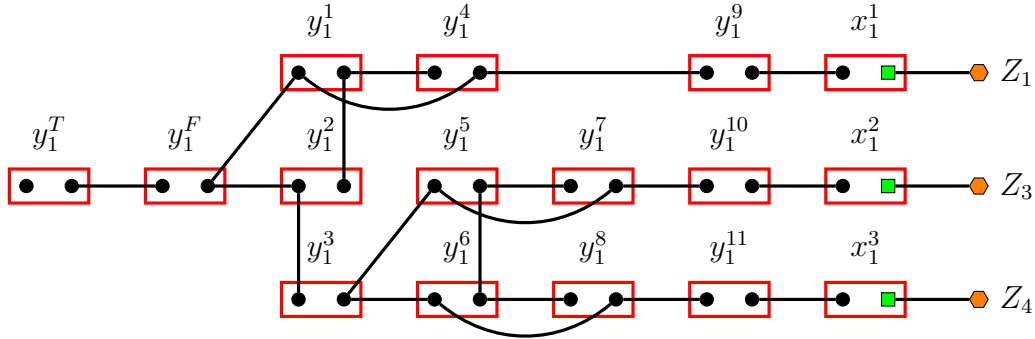

Figure 1: Illustration of Construction 1 only for the element 1 of the instance $(\mathcal{X}, \mathcal{C})$ of $RX3C$ where $\mathcal{X} = \{1, \dots, 6\}$ and $\mathcal{C} = \{\{1, 2, 3\}, \{2, 3, 4\}, \{1, 2, 6\}, \{1, 5, 6\}, \{3, 4, 5\}, \{4, 5, 6\}\}$.

Lemma 1. *Let $(\mathcal{X}, \mathcal{C})$ be an instance of $RX3C$. Let H be the gadget of the element x_i following Construction 1 from $(\mathcal{X}, \mathcal{C})$. Gadget H does not contain an IDO having neither Z_j, Z_k nor Z_l .*

Proof. Suppose that H contains an IDO S which has neither Z_j, Z_k nor Z_l . Therefore obligations x_i^1, x_i^2 and x_i^3 must be in S and so must be y_i^4, y_i^7, y_i^8 and y_i^3 . Since y_i^T has an isolated vertex, y_i^T is in S and the right vertex of y_i^F has to be dominated by y_i^1 or y_i^2 . However, they cannot be in S because of the two edges $(R(y_i^1)L(y_i^4))$ and $(L(y_i^2)L(y_i^3))$, which is a contradiction. \square

The next result is easy to verify.

Lemma 2. Let $(\mathcal{X}, \mathcal{C})$ be an instance of $RX3C$. Let H be the gadget of any element $x_i \in \mathcal{C}$ following Construction 1 from $(\mathcal{X}, \mathcal{C})$. Let S_j be the set of vertices composed of vertex Z_j plus vertices of obligations $y_i^9, y_i^1, y_i^3, y_i^7, y_i^8, x_i^2, x_i^3, y_i^T$. Let S_k be the set composed of vertex Z_k plus vertices of obligations $y_i^{10}, y_i^5, y_i^8, y_i^2, y_i^4, x_i^1, x_i^3, y_i^T$. Let S_l be the set composed of vertex Z_l plus vertices of obligations $y_i^{11}, y_i^6, y_i^7, y_i^2, y_i^4, x_i^1, x_i^2, y_i^T$. These three sets are IDO of H containing only one vertex of $\{Z_j, Z_k, Z_l\}$

Lemma 3. Let $(\mathcal{X}, \mathcal{C})$ be an instance of $RX3C$. Let H be the gadget of any element x_i following Construction 1 from $(\mathcal{X}, \mathcal{C})$. Gadget H contains no IDO having more than one vertex among Z_j, Z_k and Z_l .

Proof. Suppose there is a solution S containing Z_k and Z_l . Since Z_k and Z_l are in S , y_i^{10} and y_i^{11} must be in S . Therefore S must contain y_i^5 and y_i^6 which is a contradiction because of the edge between $R(y_i^5)$ and $R(y_i^6)$.

Suppose there is a solution S containing Z_j and one vertex among Z_k and Z_l . Since $Z_k \in S$ or $Z_l \in S$, either y_i^{10}, y_i^5 and y_i^2 are in S or y_i^{11}, y_i^6 and y_i^2 are in S . Since $Z_j \in S$, y_i^9 and y_i^1 must be in S , which is a contradiction because of the edge between $R(y_i^1)$ and $R(y_i^2)$. \square

We can conclude that each gadget representing an element x_i admits a solution for the IDO problem if and only if there is exactly one vertex Z in the solution (that will represent the triplet which contains x_i). Now we add a gadget per triplet of \mathcal{C} and we combine them with all the gadgets of elements defined in Construction 1.

Construction 2. Let $(\mathcal{X}, \mathcal{C})$ be an instance of $RX3C$ where $\mathcal{X} = \{x_1, \dots, x_{3q}\}$ and $\mathcal{C} = \{c_1, \dots, c_{3q}\}$. We construct an instance $(G = (V, E), \Pi)$ of the IDO problem as follows.

- We use Construction 1 to construct a gadget for each element of \mathcal{X} .
- We construct now a gadget for each triplet of \mathcal{C} . Let us note Z_i^a, Z_i^b, Z_i^d the three vertices representing a triplet $c_i \in \mathcal{C}$ as they appear in the three gadgets of the three elements that c_i contains.
 - We add three 2-balanced obligations z_i^a, z_i^b and z_i^d which contain respectively vertices Z_i^a, Z_i^b, Z_i^d and a new vertex in each, respectively denoted $R(z_i^a), R(z_i^b)$ and $R(z_i^d)$.
 - We add three 2-balanced obligations w_i^1, w_i^2 and w_i^3 composed of two independent vertices. In each obligation w we consider one left vertex and one right vertex respectively represented by $L(y)$ and $R(y)$.
 - We add the edges $(R(z_i^a)L(w_i^1)), (R(z_i^b)L(w_i^1)), (R(z_i^d)L(w_i^3)), (R(w_i^1)L(w_i^2))$ and $(R(w_i^2)R(w_i^3))$.

Note that G is a collection of disjoint paths, and Π has $66q$ stable 2-balanced obligations. Figure 2 shows a gadget associated to a triplet of \mathcal{C} . Figure 3 represents the “big picture” of the overall construction; each ellipse represents the gadget of an element of \mathcal{X} , and each pentagon represents the gadget of a triplet of \mathcal{C} .

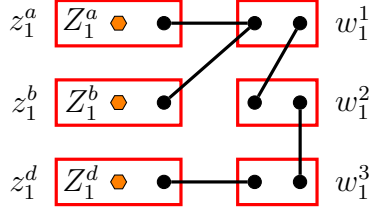

Figure 2: Illustration of Construction 2 for the triplet c_1 of the instance $(\mathcal{X}, \mathcal{C})$ of $RX3C$ where $\mathcal{X} = \{1, \dots, 6\}$ and $\mathcal{C} = \{\{1, 2, 3\}, \{2, 3, 4\}, \{1, 2, 6\}, \{1, 5, 6\}, \{3, 4, 5\}, \{4, 5, 6\}\}$.

Lemma 4. *Let $(\mathcal{X}, \mathcal{C})$ be an instance of $RX3C$. Let (G, Π) be the instance obtained by Construction 2 from $(\mathcal{X}, \mathcal{C})$. Suppose that (G, Π) has an IDO S . Let H be the gadget associated to a triplet c_i in (G, Π) . Either S contains the three obligations z_i^a , z_i^b and z_i^d of H or none of them.*

Proof. Suppose first that S contains the obligation w_i^2 . Then obligations w_i^1 and w_i^3 cannot be in S . But S still has one vertex to dominate in each. Therefore the obligations z_i^a and z_i^d must be in S . Since $L(w_i^1)$ cannot dominate $R(z_i^b)$, the obligation z_i^d must be in S . Thus, all three z_i obligations are in S .

Suppose now that the obligation w_i^2 is not in S . The obligations w_i^1 and w_i^3 must be in S . Thus, no z_i obligations can be in S . \square

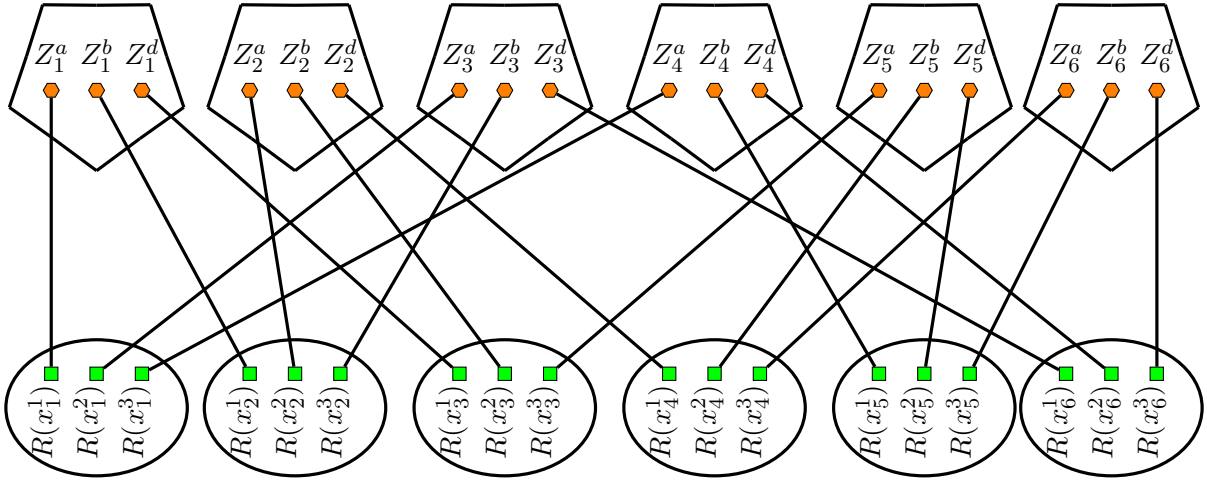

Figure 3: Illustration of Construction 2 for the instance $(\mathcal{X}, \mathcal{C})$ of $RX3C$ with $\mathcal{X} = \{1, \dots, 6\}$ and $\mathcal{C} = \{\{1, 2, 3\}, \{2, 3, 4\}, \{1, 2, 6\}, \{1, 5, 6\}, \{3, 4, 5\}, \{4, 5, 6\}\}$. Pentagons represent gadgets like in Figure 2. Ellipses represent gadgets like the ones in Figure 1.

Theorem 1. *The IDO problem is NP-complete, even if the graph is a collection of disjoint paths and the obligations are stable and 2-balanced.*

Proof. The problem is clearly in NP . Moreover, constructing (G, Π) from an $RX3C$ instance $(\mathcal{X}, \mathcal{C})$ is polynomial.

Suppose there is a solution S for the instance $(\mathcal{X}, \mathcal{C})$ of $RX3C$. Let us construct an IDO S' for (G, Π) . For each $c_i \in S$ we put the obligations z_i^a, z_i^b, z_i^d and w_i^2 in S' . For each $c_i \notin S$ we put the obligations w_i^1 and w_i^3 in S' . For each $Z_i \in S'$, we add in S' the well-chosen set given by Lemma 2 containing vertex Z_i for each gadget of element contained in triplet c_i . The set S' respects the obligations of Π , is a stable set of G , and dominates all the vertices of G (thanks to the fact that S is an exact cover of \mathcal{X}), thus is an IDO of (G, Π) .

Suppose now there is an IDO S in the instance (G, Π) . Let us construct a solution S' for the $RX3C$ problem. For each $Z_i \in S$ put triplet c_i in S' . By Lemma 1, each element of \mathcal{X} is covered by at least one triplet of S' and by Lemma 3 each element is covered by at most one triplet. Hence S' is a solution for the $RX3C$ problem. \square

In what follows we extend the result and constructions for Theorem 1 to instances having λ -balanced obligations where $\lambda \geq 2$ is any constant integer. The general idea is the following (details are given later). If λ is even, we duplicate $\frac{\lambda}{2}$ times the instance (graph and obligations) of Construction 2 and then we merge the copies. If λ is odd we add one vertex per obligation (and some edges) of each gadget of element or gadget of triplet, while keeping all the good properties.

Let us start with the case where λ is even. Take $k = \frac{\lambda}{2}$ disjoint identical copies, noted $I_1 = (G_1, \Pi_1), \dots, I_k = (G_k, \Pi_k)$ of Construction 2. Now, construct a new IDO instance (G, Π) in which the graph $G = (V, E)$ is composed of the union of these k graphs: $V = V_1 \cup \dots \cup V_k$ and $E = E_1 \cup \dots \cup E_k$. As each G_i is a collection of disjoint paths, this is also the case for G (G is composed of “parallel” copies of the “same” graph). Now we merge the obligations. Let B be any obligation of Π_1 . As the k instances are identical, a similar obligation B is also part of each other instance. Now, all the vertices of these k similar obligations B are grouped in a new obligation of Π . As $|B| = 2$, this new obligation, that we also call B , of Π is of size λ . It is also an independent set of graph G . As the k copies of graphs are disjoint in G and as identical obligations are merged, the overall instance (G, Π) has an IDO if and only if each (G_i, Π_i) $i = 1, \dots, k$ has an IDO .

Let us now study the case where λ is odd. Let us start with $\lambda = 3$.

Construction 3. Let $(\mathcal{X}, \mathcal{C})$ be an instance of $RX3C$ where $\mathcal{X} = \{x_1, \dots, x_{3q}\}$ and $\mathcal{C} = \{c_1, \dots, c_{3q}\}$. We construct a new instance $(G = (V, E), \Pi)$ of the IDO problem as follows:

- We follow Construction 2.
- For each $x_i \in \mathcal{X}$:
 - In each obligation y_i and x_i we add a new vertex denoted respectively $N(y_i)$ and $N(x_i)$.

- We add the edges $(N(y_i^T)N(y_i^F))$, $(N(y_i^1)N(y_i^2))$, $(N(y_i^1)N(y_i^4))$, $(N(y_i^3)N(y_i^5))$, $(N(y_i^3)N(y_i^6))$, $(N(y_i^5)N(y_i^7))$, $(N(y_i^6)N(y_i^8))$, $(N(y_i^9)N(x_i^1))$, $(N(y_i^{10})N(x_i^2))$ and $(N(y_i^{11})N(x_i^3))$.

• For each $c_i \in \mathcal{C}$:

- In each obligation w_i and z_i we add a new vertex denoted respectively $N(w_i)$ and $N(z_i)$.
- We add the edges $(N(w_i^1)N(z_i^a))$, $(N(w_i^1)N(z_i^b))$, $(N(w_i^3)N(z_i^d))$ and $(N(w_i^3)N(w_i^2))$.

Note that G is a collection of disjoint paths, and Π contains $66q$ stable 3-balanced obligations. See two illustrations in Figure 4 and Figure 5. The obligations represented in Figure 4 and Figure 5 are the same than the ones in Figure 1 and Figure 2, but only the *new* vertices and new edges added by Construction 3 are shown. In other words, all the obligations have both vertices of Construction 1 (respectively Construction 2) and vertices of Construction 3.

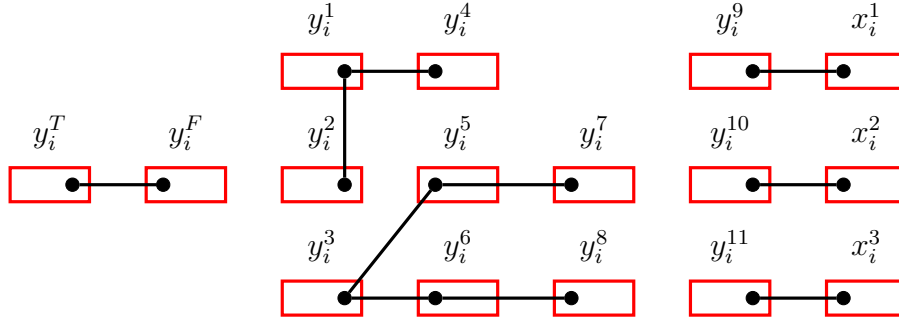

Figure 4: Illustration of Construction 3 only for an element i of the instance $(\mathcal{X}, \mathcal{C})$ of $RX3C$.

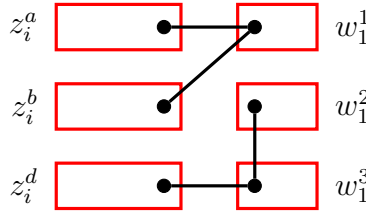

Figure 5: Illustration of Construction 3 only for a triplet c_i of the instance $(\mathcal{X}, \mathcal{C})$ of $RX3C$.

Before proceeding to obligations with more than three vertices, let us see an *IDO* with obligations of size three. All the obligations have three vertices (two original vertices and one new vertex) after Construction 3. Since no edge connects the new vertices and the original vertices, an *IDO* in this instance can be considered as two (dependent) *IDO* S_1

and S_2 . One (S_1) dominates the original vertices, and another (S_2) dominates the new vertices. The part of the *IDO* which dominates the original vertices (S_1) still admits only three solutions in each gadget of element, and each representing vertices of triplets are either all in an *IDO* or none are in an *IDO*. The other part of the *IDO* (S_2) has to respect the obligations chosen in S_1 . This constraint leads to the existence of a unique *IDO* in the new part for an *IDO* in the original part. For each chosen *IDO* S_1 , all the new vertices are already dominated. The obligations in the *IDO* remain the same despite the new vertex in each obligation. Thanks to this constraint, each instance still admits only one triplet for each element, and either all the representing of a triplet are in an *IDO* or none.

Let us proceed to the construction of an instance of *IDO* with more than three vertices in each obligation.

Construction 4. *Let $(\mathcal{X}, \mathcal{C})$ be an instance of $RX3C$ where $\mathcal{X} = \{x_1, \dots, x_{3q}\}$ and $\mathcal{C} = \{c_1, \dots, c_{3q}\}$. Let $\lambda \geq 2$ be an integer. We construct $G = (V, E)$ a graph and obligations Π as follows:*

- *If λ is even: we duplicate Construction 2 $\frac{\lambda}{2}$ times and merge the copies.*
- *If λ is odd:*
 - *We duplicate Construction 2 $\frac{\lambda-1}{2}$ times and we merge the copies.*
 - *In the previous instance, we add new vertices and new edges in gadgets of elements and triplets following the structure presented in Figure 4 and Figure 5.*

Now G is a collection of disjoint paths and Π contains stable λ -balanced obligations. Since Construction 4 constructs a constant number of “parallel” and “independent” copies of the initial one given by Construction 2 used to prove Theorem 1, we can use it to get the following more general result.

Theorem 2. *The *IDO* problem is NP -complete, even if the graph is a collection of disjoint paths and the obligations are stable and λ -balanced where $\lambda \geq 2$ is a constant integer.*

Theorem 2 states NP -completeness when the graph is a collection of disjoint paths. In the following, we use a new gadget, called the *neutral connector*, to connect all these disjoint paths and to prove the NP -completeness when G is a (unique) path.

Construction 5. *Let $\lambda \geq 2$ be an integer. We construct a neutral connector gadget composed of a graph $G_{neutral} = (V_{neutral}, E_{neutral})$ and obligations $\Pi_{neutral}$ as follows:*

- *We add a path $Q_1, \dots, Q_{3\lambda}$.*
- *We add three obligations V_1, V_2 and V_3 .*
- *We add $Q_1, Q_3, Q_{3\lambda-3}$ in V_1 , $Q_2, Q_{3\lambda-1}$ in V_2 and $Q_4, Q_{3\lambda-2}, Q_{3\lambda}$ in V_3 .*

- For each vertex $Q_i \in \{Q_5, \dots, Q_{3\lambda-4}\}$:
 - If $i \pmod 3 = 0$, we add Q_i in V_1 .
 - If $i \pmod 3 = 2$, we add Q_i in V_2 .
 - If $i \pmod 3 = 1$, we add Q_i in V_3 .

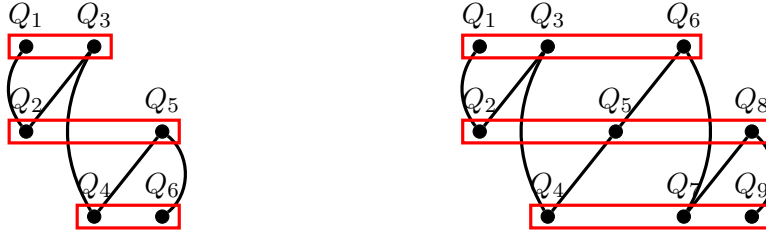

Figure 6: A neutral connector following Construction 5 where $\lambda = 2$ on the left and $\lambda = 3$ on the right.

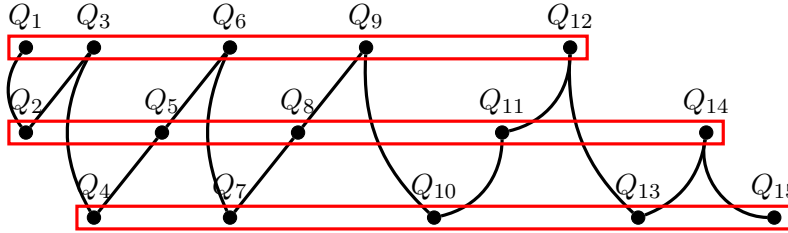

Figure 7: A neutral connector following Construction 5 where $\lambda = 5$.

Note that $G_{neutral}$ is a (unique) path, with three stable λ -balanced obligations. See illustrations in Figure 6 and Figure 7. We now show that this gadget is a neutral connector for the *IDO* problem, i.e. it can be added to an initial instance without changing the property of having or not an *IDO*.

It is easy to show that the only *IDO* of $(G_{neutral}, \Pi_{neutral})$ is obligation V_2 .

To show the neutrality, let us consider any instance $I = (G, \Pi)$ of the *IDO* problem and add the neutral gadget $(G_{neutral}, \Pi_{neutral})$ (for any value of λ) to it as follows. Connect with a new edge any vertex of the graph G of I and the first vertex Q_1 of the path $G_{neutral}$; also connect with a new edge any other vertex of the graph G of I and the other extremity $Q_{3\lambda}$ of the path $G_{neutral}$. Let I' be this new instance of the *IDO* problem.

Suppose that the initial instance I has an *IDO* S . Then clearly $S \cup V_2$ is an *IDO* of instance I' .

Suppose now that I' has an *IDO* S . S contains V_2 but not obligations V_1 or V_3 (otherwise some vertices of $G_{neutral}$ would not be dominated by S or S would not be an independent set). This means that no vertex of $G_{neutral}$ can help to dominate vertices of graph G of I . Hence, the obligations of I included in S form an *IDO* of I .

Now to get the NP -completeness for a (unique) path and stable and λ -balanced obligations, where $\lambda \geq 2$ is a constant integer, we connect with neutral connector gadgets all the disjoint paths composing the graph G obtained after Construction 4. For that, number (in any order) the l disjoint paths composing G : P_1, \dots, P_l . We note a_i and b_i the two extremities of path P_i . Now for each $i = 1, \dots, l - 1$ construct a new neutral network gadget λ -balanced and connect b_i to Q_1 and $Q_{3\lambda}$ to a_{i+1} .

Based on the neutrality of the neutral connector gadgets, it is possible to complete the proof of Theorem 2 to get the following theorem.

Theorem 3. *The IDO problem is NP-complete, even if the graph is a (unique) path and the obligations are stable and λ -balanced, where $\lambda \geq 2$ is a constant integer.*

In the rest of this section, we show how to obtain other NP -completeness results in various other types of instances. For example, we can prove that the IDO problem is NP -complete even if the graph has a low (resp. high) density of edges. For that, just add new complete graphs (resp. independent vertices) with singleton obligations to the previous initial construction. The NP -completeness is kept for these new instances. We do not give more details here.

We focus on the distances in the graph and study their potential impact on complexity of the IDO problem. The *distance* between two vertices u and v in a graph is the length of the shortest path between u and v . The *diameter* of a graph is the largest distance between its vertices. We now show that the IDO problem is NP -complete even in a graph of diameter three with stable and λ -balanced obligations, where $\lambda \geq 2$ is a constant integer.

The general idea is the following. First, we construct an instance (G, Π) of IDO with Construction 4. At this step, we have a unique path and many λ -balanced obligations. To reduce the diameter of this path, we add a new obligation Λ with λ vertices. Each vertex of Λ is a universal vertex of G ; i.e., each vertex of Λ is adjacent to all other vertices of the graph G . The instance has a graph of diameter two and still has λ -balanced obligations. The last step is to prevent these new vertices from being in an IDO . We could add an edge between two vertices of Λ , but this obligation would no longer be stable. Instead, we will use a property of neutral connectors. Besides connecting two graphs without affecting the existence of an IDO , a neutral connector admits only one IDO . If the obligation containing Q_2 and $Q_{3\lambda-1}$ is not in an IDO , either Q_3 or $Q_{3\lambda-2}$ cannot be dominated. Thus we add a new neutral connector N_c of size 3λ . Each vertex of Λ is adjacent to each vertex of N_c except Q_3 . An IDO must have the vertices of the obligation containing Q_2 and $Q_{3\lambda-1}$. The vertices of Λ can no longer be in an IDO .

Construction 6. *Let $(\mathcal{X}, \mathcal{C})$ be an instance of $RX3C$ where $\mathcal{X} = \{x_1, \dots, x_{3q}\}$ and $\mathcal{C} = \{c_1, \dots, c_{3q}\}$. Let $\lambda \geq 2$ be an integer. We construct an IDO instance $(G = (V, E), \Pi)$ as follows:*

- We follow Construction 4.

- We add one neutral connector N_c following Construction 5 with obligations of size λ .
- We add λ new vertices all contained in one obligation $\Lambda = \{v_1, \dots, v_\lambda\}$.
- We add all edges between each vertex v_i of $\{v_1, \dots, v_\lambda\}$ and all the vertices of the other vertices, except vertex Q_3 of N_c .

Note that G is a graph of diameter three and Π contains $68q$ stable λ -balanced obligations. See an illustration in Figure 8. The edges between vertices of Λ and vertices of the neutral connector, as well as the edges between vertices of the neutral connector, have different colors for clarity purposes. The dashed edges symbolize the edges between each vertex of $G \setminus \{v_1, \dots, v_\lambda, Q_1, \dots, Q_{3\lambda}\}$ and each vertex of Λ .

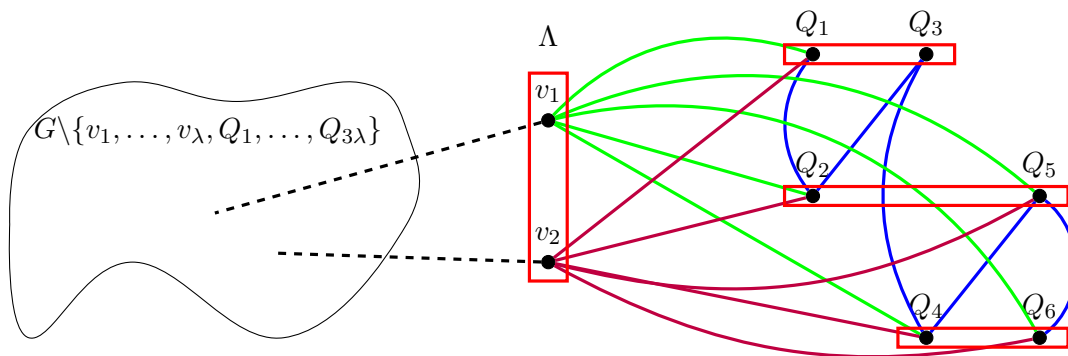

Figure 8: A graph following Construction 6 where $\lambda = 2$.

Theorem 4. *The IDO problem is NP-complete, even if the graph is of diameter three and the obligations are stable and λ -balanced, where $\lambda \geq 2$ is a constant integer.*

Proof. Each vertex of $V \setminus (Q_3 \cup \Lambda)$ is at distance one to vertices of Λ . Each vertex of Λ is at distance two to other vertices of Λ . The vertex Q_3 is at distance two to all the vertices of Λ . Thus, the graph has a diameter three.

The vertices $\{v_1, \dots, v_\lambda\}$ cannot be in an IDO since it would be the only obligation in it and in this case vertex Q_3 of the neutral connector is not dominated. The only possible IDO is composed of an IDO of the initial instance constructed by Construction 4 plus obligation V_2 of the neutral connector. Hence, the new instance has an IDO if and only if the initial instance has an IDO. \square

We have shown in this section that the IDO problem is NP-complete even in the very restricted case where the graph is a path, and the obligations are stable λ -balanced where $\lambda \geq 2$ is a constant. In the next section, we will study the complexity of the problem when the size of obligations are non-constant.

3 Instances with balanced non constant size obligations

In this section we first propose another polynomial reduction between $RX3C$ and IDO problems. The rest of the section mainly consists in exploiting variants of this initial construction. This leads us to show that the IDO problem is NP -complete even if the number of balanced obligations is equal to (resp. lower than, resp. higher than) the square root of the number of vertices of the graph.

Construction 7. Let $(\mathcal{X}, \mathcal{C})$ be an instance of $RX3C$ where $\mathcal{X} = \{x_1, \dots, x_{3q}\}$ et $\mathcal{C} = \{c_1, \dots, c_{3q}\}$. We construct a graph $G = (V, E)$ and obligations Π as follows:

- For each $x_i \in X$, we add the vertex x_i .
- For each $c_i \in \mathcal{C}$, we add the vertex z_i .
- For each $c_i \neq c_j \in \mathcal{C}$, if c_i and c_j share at least one element then we add the edge $(z_i z_j)$ (the two vertices representing two non disjoint triplets are linked).
- For each $c_i = \{x_j, x_k, x_l\} \in \mathcal{C}$, we add the edges $(z_i x_j)$, $(z_i x_k)$ and $(z_i x_l)$.
- We add the vertices y_1, y_2 and y_3 , and the edge $(y_1 y_2)$.
- We add the obligations $\{x_1, \dots, x_{3q}, y_1\}$ and $\{y_2, y_3\}$.
- Each other vertex is in an obligation of size one.

Note that G is a graph with $6q + 3$ vertices and Π has $3q + 2$ stable non balanced obligations. This instance can be constructed in polynomial time from $(\mathcal{X}, \mathcal{C})$. See an illustration in Figure 9.

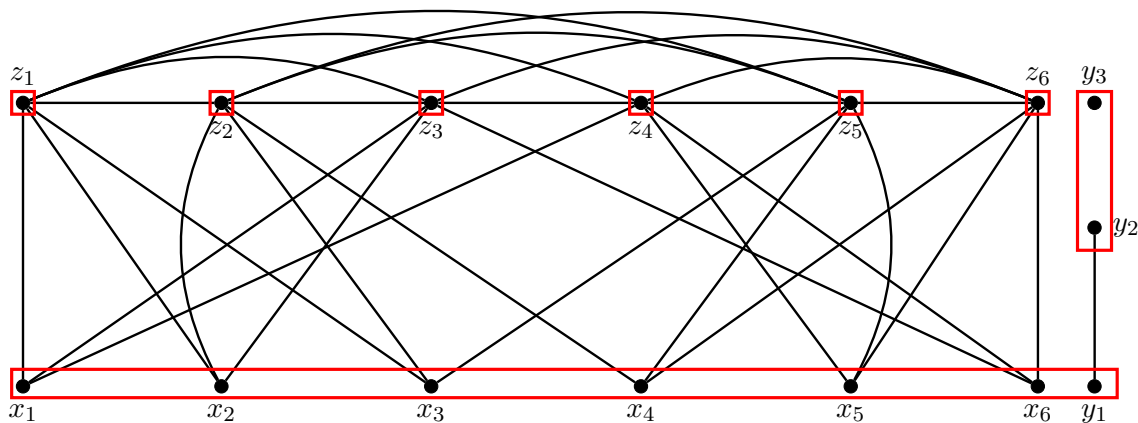

Figure 9: Illustration of Construction 7 for the instance $(\mathcal{X}, \mathcal{C})$ of $RX3C$ where $\mathcal{X} = \{1, \dots, 6\}$ and $\mathcal{C} = \{\{1, 2, 3\}, \{2, 3, 4\}, \{1, 2, 6\}, \{1, 5, 6\}, \{3, 4, 5\}, \{4, 5, 6\}\}$.

Lemma 5. *Let $(\mathcal{X}, \mathcal{C})$ be an instance of $RX3C$. Instance $(\mathcal{X}, \mathcal{C})$ has a solution if and only if the instance (G, Π) constructed from $(\mathcal{X}, \mathcal{C})$ following Construction 7 contains an IDO .*

Proof. Suppose there is a solution S for the instance $(\mathcal{X}, \mathcal{C})$ of $RX3C$, where $\mathcal{X} = \{x_1, \dots, x_{3q}\}$ and $\mathcal{C} = \{c_1, \dots, c_{3q}\}$. Let us construct S' a solution for the instance (G, Π) following Construction 7. For each $c_i \in S$, we put $z_i \in S'$. We also put the vertices y_2 and y_3 in S' . Set S' is then a stable set of G . Now, as S covers all elements of \mathcal{X} , all of the z -vertices and the x -vertices are dominated by S' . Thus S' is an IDO .

Suppose now that there is an IDO S for the instance (G, Π) from Construction 7. Let us construct S' a solution for the instance $(\mathcal{X}, \mathcal{C})$ of $RX3C$ as follows: For each $z_i \in S$, we put $c_i \in S'$. Note that vertex y_3 can only be dominated by itself. Thus obligation $\{y_2, y_3\}$ is in S and then no x -vertex can be in S , so they are dominated by z -vertices. Since S is an independent set, each x -vertex is dominated by exactly one z -vertex of S . Thus, S' is a solution for $RX3C$. \square

We now propose modifications of Construction 7 to show the NP -completeness on instances with \sqrt{N} stable and \sqrt{N} -balanced obligations, where N is the number of vertices of the graph.

Construction 8. *Let $(\mathcal{X}, \mathcal{C})$ be an instance of $RX3C$ where $\mathcal{X} = \{x_1, \dots, x_{3q}\}$ and $\mathcal{C} = \{c_1, \dots, c_{3q}\}$. We construct a graph $G = (V, E)$ and obligations Π as follows:*

- *We use Construction 7 to get an initial instance.*
- *We add new vertices y^4, \dots, y^{3q+3} to the obligation which contains $\{y_2, y_3\}$.*
- *We add the new vertex y'_1 to the obligation which contains y_1 and we add the edge $(y'_1 y_2)$ in the graph.*
- *For each $z_i \in V$, we add the new vertices z_i^1, \dots, z_i^{3q+1} in the obligation which contains only z_i .*
- *For each pair of vertices $z_i \neq z_j$ of the initial instance, we add the edges $(z_i^1 z_j), \dots, (z_i^{3q+1} z_j)$ and $(z_j^1 z_i), \dots, (z_j^{3q+1} z_i)$ if and only if the edge $(z_i z_j)$ is in the initial instance.*

Note that G has $N = 9q^2 + 12q + 4$ vertices, and the $3q + 2 = \sqrt{N}$ obligations are all independent and all of size $3q + 2 = \sqrt{N}$. Since the transformations of Construction 7 do not affect the existence of a solution, compared to the initial instance, the proof of Lemma 5 is still valid for Construction 8 and can be used to prove the following result.

Theorem 5. *The IDO problem is NP -complete even if there are \sqrt{N} stable and \sqrt{N} -balanced obligations, where N is the number of vertices of the graph.*

With Construction 8 we have constructed instances of the *IDO* problem with \sqrt{N} stable and \sqrt{N} -balanced obligations. Now we explore two other cases. Firstly let us see the case of instances with strictly more than \sqrt{N} balanced obligations. We take an initial instance obtained by Construction 8 and note q the size of the obligations (they are all the same). Then we add to this instance pq new vertices, but no edges. With these pq vertices we arbitrarily create p new disjoint stable obligations, all of size q . Let N be the number of vertices of this new graph. This new instance contains strictly more than \sqrt{N} balanced obligations. However, the new instance has an *IDO* if and only if the initial instance contains an *IDO*. Using the result of Theorem 5 leads to the next result.

Corollary 1. *The IDO problem is NP-complete even if there are at least \sqrt{N} (and less than N) stable and balanced obligations, where N is the number of vertices of the graph.*

Now let us see the case of balanced obligations with more than \sqrt{N} vertices in each obligation (thus leading to strictly less than \sqrt{N} obligations). We take Construction 8 and add a new vertex in each obligation. The new vertex in the same obligation than y_3 (resp. y_1) is not connected (resp. connected to y_2). The new vertex added in the obligation containing z_i is connected to the same neighbours than the other vertices z_i^j of this obligation. Then this newly defined instance has strictly more than \sqrt{N} vertices in each balanced obligation. We can continue to add vertices in each obligation with the same procedure, without changing the property of having or not an *IDO* compared to the initial instance. This construction leads to the following corollary.

Corollary 2. *The IDO problem is NP-complete even if there are at most \sqrt{N} stable and balanced obligations, where N is the number of vertices of the graph.*

Note that when the number $\#o$ of obligations is constant (independent of N), the *IDO* problem is polynomial. Indeed, an algorithm can explore all the possible $O(2^{\#o})$ combinations of obligations in polynomial time.

4 Maximising the number of dominated vertices

Since determining if there is an *IDO* is NP-complete, even in a very restricted family of instances, in this section we relax the constraint of dominating all the vertices of the graph.

Partially Independent Dominating set with Obligation (*PIDO*).

Given an instance composed of a graph $G = (V, E)$, and obligations $\Pi = \{V_1, \dots, V_k\}$, a set of vertices $S \in V$ is a *PIDO* if S is an independent set of graph G and respects the obligations of Π .

To define a measure associated to a *PIDO* S , let $N(S)$ be the set of vertices of G that have at least one neighbour in (i.e. are dominated by) S . Then, the number of vertices *dominated* by a *PIDO* S is defined by $|S \cup N(S)|$.

An *IDO* S of an instance $(G = (V, E), \Pi)$ is then a *PIDO* of instance $(G = (V, E), \Pi)$ dominating all the $|V|$ vertices of G . To ensure that there is always a non-empty *PIDO*, we will only consider instances with stable obligations. Note that in this case, any (stable) obligation is a *PIDO* dominating at least its own vertices.

The associated decision problem is the following.

***PIDO* Problem:**

Instance: $G = (V, E)$ an undirected graph, $\Pi = V_1, \dots, V_k$ a partition of V and an integer K .

Question: Does (G, Π) contain a *PIDO* dominating at least K vertices of G ?

In this section, we show that the *PIDO* problem is *NP*-complete, when $K = 3\sqrt{|V|} - 2$ even if the graph is a collection of disjoint paths and the obligations are stable. To obtain this result we do a reduction from the *IDO* problem. As a second step we will propose a polynomial time algorithm to construct a *PIDO* dominating at least $2\sqrt{|V|} - 1$ vertices in any instance $(G = (V, E), \Pi)$ if the obligations of Π are stable.

The first step of the proof of *NP*-completeness is to construct a gadget that allows us to limit the potential of domination.

Construction 9. Let Y be an integer. We construct $G_Y = (V_Y, E_Y)$ a graph and obligations Π_Y as follows:

- We add the vertices $v_1^1, \dots, v_Y^1, \dots, v_1^Y, \dots, v_Y^Y$.
- We add the obligations $\{v_1^1, \dots, v_1^Y\}, \dots, \{v_Y^1, \dots, v_Y^Y\}$.
- For each $1 \leq i \neq j \leq Y$, we add the edge (v_i^j, v_j^i) .
- We delete the vertices $v_1^1, v_2^2, \dots, v_{Y-1}^{Y-1}, v_Y^Y$.

Note that G_Y is a collection of disjoint paths with $Y^2 - Y$ vertices and Y stable obligations, each of size $Y - 1$. See an illustration in Figure 10.

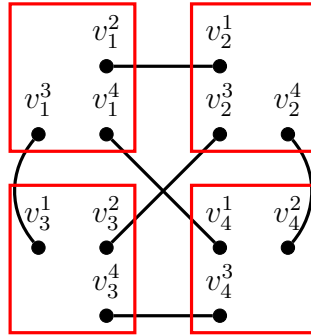

Figure 10: Illustration of Construction 9 for $Y = 4$.

Lemma 6. *Let (G_Y, Π_Y) be an instance constructed following Construction 9. For any value of $Y \geq 2$, any PIDO cannot dominate more than $2Y - 2$ vertices in it.*

Proof. Since a PIDO must respect the obligations, let us consider any obligation $V_i \in \Pi_Y$. Let $V_i = \{v_i^1, \dots, v_i^Y\}$. Suppose that a PIDO S contains it: $\{v_i^1, \dots, v_i^Y\} \subseteq S$. Because of the construction, an edge connects V_i and all the other obligations. Thus, no more vertices can be added to S . Each vertex of S dominates itself and another vertex in another obligation i.e. S dominates exactly $2Y - 2$ vertices. Hence any PIDO can dominate $2Y - 2$ vertices but no more. \square

As previously mentioned, to prove our NP -completeness result, we do not make a reduction from $RX3C$ but from IDO problem which is NP -Complete (see section 2). The overall strategy of the reduction here is to consider an instance of the IDO problem and then to add the previous gadget (G_Y, Π_Y) with a well-chosen parameter Y .

Construction 10. *Let (G, Π) be an instance of IDO where $G = (V, E)$ is a path of vertices and $\Pi = \{V_1, \dots, V_l\}$ are stable obligations. We construct a graph $G' = (V', E')$ and obligations Π' as follows:*

- *Let (G_Y, Π_Y) be an instance of IDO following Construction 9 where $Y = |V|$.*
- *G' is the union of the two disjoint graphs G and G_Y and $\Pi' = \Pi \cup \Pi_Y$.*

Note that G' is a collection of disjoint paths with $|V|^2$ vertices, and Π' contains stable obligations. This new instance can be constructed in polynomial time from the initial instance $(G = (V, E), \Pi)$.

Theorem 6. *Determining if there is a solution for the PIDO problem which can dominate at least $3\sqrt{N} - 2$ vertices (where N is the number of vertices of the graph) is NP -complete even if the graph is a collection of disjoint paths and the obligations are stable.*

Proof. The problem is clearly in NP . We have shown in Theorem 3 that the IDO problem is NP -complete in instance (G, Π) even if $G = (V, E)$ is a path and Π are stable obligations. We make the reduction from that. We note $(G' = (V', E'), \Pi')$ the instance obtained (in polynomial time) from (G, Π) by Construction 10. By construction, we have $|V'| = |V|^2$.

Suppose there is an IDO S for the instance (G, Π) of the IDO problem. Let us construct S' a PIDO for the instance (G', Π') . For that, simply take in S' all the vertices of S and add one Y -obligation. Set S' is an independent set of G' and dominates all the $|V|$ vertices of the “ G part” of G' plus $2|V| - 2$ vertices in the gadget, i.e. at least $3\sqrt{|V'|} - 2$ vertices of G' .

Suppose now that there is a PIDO S for the PIDO instance (G', Π') , dominating at least $3\sqrt{|V'|} - 2$ vertices of G' . Let us construct S' a solution for the instance (G, Π) of IDO . Since S' can only dominate $2\sqrt{|V'|} - 2$ vertices of the gadget part (G_Y) of G' , S' must dominate all the $|V|$ vertices of the other part $G = (V, E)$. Thus there is a solution for the IDO problem in G . \square

We have shown that determining if there is a solution for the *PIDO* problem which can dominate at least $3\sqrt{N} - 2$ vertices (where N is the number of vertices of the graph) is *NP*-complete even if the graph is a collection of disjoint paths and the obligations are stable. On the other side, we show now that if the obligations are stable, an instance $(G = (V, E), \Pi)$ always contains a *PIDO* dominating at least $2\sqrt{|V|} - 1$ vertices. Moreover, such a solution can be constructed in polynomial time. We also show that the bound of $2\sqrt{|V|} - 1$ is tight.

Consider the following greedy algorithm for any instance (G, Π) with stable obligations.

1. Create an initial empty solution S .
2. While there are obligations, do:
 - (a) Add the vertices of the biggest obligation B in S .
 - (b) Let $N(B)$ be the set of vertices that are neighbour of at least a vertex of B . Let $O(B)$ be the set of all vertices contained in obligations containing at least a vertex of set $N(B)$ (i.e. $O(B)$ contains all the vertices of all obligations that are “neighbour” of B). From the current instance, delete all the vertices contained in obligation B plus all the vertices of $O(B)$ (and all the corresponding obligations).
3. Return S .

Since the number of obligations strictly decreases at each step of the loop, the algorithm terminates. Note that, as obligations are stable, S is non empty and, by greedy construction, dominates at least one vertex of every obligation. Due to the update process of the instance step by step, S respects the obligations and is an independent set of the graph $G = (V, E)$. As there are at most $|V|$ obligations, the algorithm is polynomial.

Lemma 7. *Let $(G = (V, E), \Pi)$ be any instance with stables obligations. This instance always has a *PIDO* dominating at least $2\sqrt{|V|} - 1$ vertices that can be constructed by the greedy polynomial algorithm described above.*

Proof. Let $(G = (V, E), \Pi)$ be an instance of *PIDO*, with stable obligations and $n = |V|$ be the number of vertices of the graph. Let $\#o$ be the number of obligations in Π and $|o|_{max}$ the size of the biggest obligation of Π . The greedy algorithm described above returns a stable set of vertices, respecting obligations and dominating at least $\#o + |o|_{max} - 1$ vertices. As we have the trivial inequality $\#o \times |o|_{max} \geq n$, we have $\#o \geq \sqrt{n}$ or $|o|_{max} \geq \sqrt{n}$. W.l.o.g. suppose that $|o|_{max} \geq \sqrt{n}$. We can rewrite this inequality as $|o|_{max} = \sqrt{n} + x$, with $x > 0$. Suppose now by contradiction that $\#o + |o|_{max} < 2\sqrt{n}$:

$$\#o + |o|_{max} < 2\sqrt{n} \tag{1}$$

$$\#o + \sqrt{n} + x < 2\sqrt{n} \tag{2}$$

$$\#o < \sqrt{n} - x \tag{3}$$

With this inequality we get: $\#o \times |o|_{max} \leq (\sqrt{n} - x)(\sqrt{n} + x) \leq n - x^2$. But, as $\#o \times |o|_{max} \geq n$ we get a contradiction. Thus we have $\#o + |o|_{max} \geq 2\sqrt{n}$, and so $\#o + |o|_{max} - 1 \geq 2\sqrt{n} - 1$. \square

We now show that this bound of $2\sqrt{|V|} - 1$ is tight by using the following instances.

Construction 11. Let Y be an integer. We construct $G = (V, E)$ a graph and Π obligations Π as follows:

- We add the vertices $v_1^1, \dots, v_Y^1, \dots, v_1^Y, \dots, v_Y^Y$.
- We add the obligations $\{v_1^1, \dots, v_1^Y\}, \dots, \{v_Y^1, \dots, v_Y^Y\}$.
- For each $1 \leq i \neq j \leq Y$, we add the edge (v_i^j, v_j^i) .

Note that G contains Y^2 vertices and Π is composed of Y stable and Y -balanced obligations. See an illustration in Figure 11.

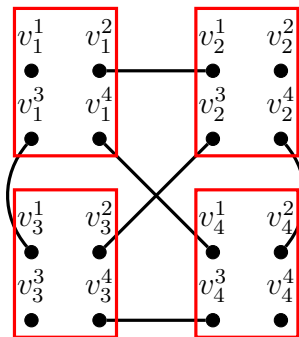

Figure 11: Illustration of Construction 11 for $Y = 4$.

Lemma 8. Any instance $(G = (V, E), \Pi)$ obtained by Construction 11 with any parameter $Y \geq 2$ does not contain a *PIDO* dominating more than $2\sqrt{|V|} - 1$ vertices.

Proof. Let $(G = (V, E), \Pi)$ be obtained by Construction 11. Since each obligation shares exactly one edge with each other obligation, only one obligation can be in a *PIDO*. As each obligation has $\sqrt{|V|}$ vertices and as there are $\sqrt{|V|}$ obligations, any non-empty *PIDO* dominates exactly $2\sqrt{|V|} - 1$ vertices, regardless of the chosen obligation. \square

We have shown that there is always a *PIDO* dominating $2\sqrt{N} - 1$ vertices (where N is the number of vertices of the graph) if the obligations are stable. We have also shown that there are instances in which no more than $2\sqrt{N} - 1$ vertices can be dominated. Thus we can conclude this section by the following theorem.

Theorem 7. Let $(G = (V, E), \Pi)$ be an instance with stable obligations. It contains a *PIDO* dominating at least $2\sqrt{|V|} - 1$ vertices (this bound is tight for an infinite number of instances). Such a *PIDO* can be constructed in polynomial time.

5 Conclusion

In this paper, we have shown that the *IDO* problem is *NP*-complete, even if the graph is a path and the obligations are stable and λ -balanced (where $\lambda \geq 2$ is a constant integer), or if the graph has a diameter three and the obligations are stable and λ -balanced (with $\lambda \geq 2$). However, determining if there is a solution for the *IDO* problem is clearly polynomial for graphs with diameter one. The case of diameter two is still open. We have also shown that the *IDO* problem is *NP*-complete, even if there are less or more than \sqrt{N} stable balanced obligations. Finally, we introduced a version of the problem where the goal is to dominate the maximum number of vertices while respecting the obligations. We proved that it is *NP*-complete to determine if it is possible to dominate only at least $3\sqrt{N} - 2$ vertices (where N is the number of vertices of the graph). However, we proved that there is always a solution which can dominate at least $2\sqrt{N} - 1$ vertices if obligations are stable. We have also given a polynomial algorithm to construct such a solution. However, reducing the small gap between polynomial and *NP*-complete cases is still open.

References

- [1] A. Akbari et al. *Independent Domination in Subcubic Graphs*. 2020. arXiv: 2001.02946 [cs.DM].
- [2] Claude Berge. “Theory of Graphs and its Applications”. In: *IL, Moscow* (1962), pp. 150–152.
- [3] Miroslav Chlebík and Janka Chlebíková. “Approximation Hardness of Dominating Set Problems”. In: *Algorithms – ESA 2004*. Ed. by Susanne Albers and Tomasz Radzik. Berlin, Heidelberg: Springer Berlin Heidelberg, 2004, pp. 192–203.
- [4] Alexis Cornet and Christian Laforest. “Domination problems with no conflicts”. In: *Discret. Appl. Math.* 244 (2018), pp. 78–88.
- [5] Alexis Cornet and Christian Laforest. “Graph Problems with Obligations”. In: *Combinatorial Optimization and Applications*. Ed. by Donghyun Kim, R. N. Uma, and Alexander Zelikovskiy. Vol. (LNCS) 11346. Cham: Springer International Publishing, 2018, pp. 183–197.
- [6] Alexis Cornet and Christian Laforest. “Total Domination, Connected Vertex Cover and Steiner Tree with Conflicts”. In: *Discret. Math. Theor. Comput. Sci.* 19.3 (2017).
- [7] Michael R. Garey and David S. Johnson. *Computers and Intractability: A Guide to the Theory of NP-Completeness*. New York, NY, USA: W. H. Freeman & Co., 1979.
- [8] Teresa W Haynes, Stephen Hedetniemi, and Peter Slater. *Domination in Graphs: Advanced Topics*. CRC press, 1998.
- [9] Teresa W Haynes, Stephen Hedetniemi, and Peter Slater. *Fundamentals of domination in graphs*. Marcel Dekker, 1998.

- [10] Robert W. Irving. “On approximating the minimum independent dominating set”. In: *Information Processing Letters* 37.4 (1991), pp. 197–200.
- [11] Mamadou Moustapha Kanté, Christian Laforest, and Benjamin Momège. “An Exact Algorithm to Check the Existence of (Elementary) Paths and a Generalisation of the Cut Problem in Graphs with Forbidden Transitions”. In: *SOFSEM 2013 Proceedings*. Ed. by Peter van Emde Boas et al. Vol. 7741. Lecture Notes in Computer Science. Springer, 2013, pp. 257–267.
- [12] Mamadou Moustapha Kanté, Christian Laforest, and Benjamin Momège. “Trees in Graphs with Conflict Edges or Forbidden Transitions”. In: *Theory and Applications of Models of Computation, 10th International Conference, TAMC 2013, Hong Kong, China, May 20-22, 2013. Proceedings*. Ed. by T.-H. Hubert Chan, Lap Chi Lau, and Luca Trevisan. Vol. 7876. Lecture Notes in Computer Science. Springer, 2013, pp. 343–354.
- [13] Mamadou Moustapha Kanté et al. “Finding Paths in Grids with Forbidden Transitions”. In: *41st International Workshop, WG 2015*. Ed. by Ernst W. Mayr. Vol. 9224. Lecture Notes in Computer Science. Springer, 2015, pp. 154–168.
- [14] Christian Laforest and Benjamin Momège. “Nash-Williams-type and Chvátal-type Conditions in One-Conflict Graphs”. In: *SOFSEM 2015 Proceedings*. Ed. by Giuseppe F. Italiano et al. Vol. 8939. Lecture Notes in Computer Science. Springer, 2015, pp. 327–338.
- [15] Christian Laforest and Benjamin Momège. “Some Hamiltonian Properties of One-Conflict Graphs”. In: *25th International Workshop, IWOCA 2014*. Ed. by Jan Kratochvíl, Mirka Miller, and Dalibor Froncek. Vol. 8986. Lecture Notes in Computer Science. Springer, 2014, pp. 262–273.
- [16] Oystein Ore. *Theory of graphs*. Vol. 38. American Mathematical Soc., 1965.
- [17] Johan M.M. [van Rooij] and Hans L. Bodlaender. “Exact algorithms for dominating set”. In: *Discrete Applied Mathematics* 159.17 (2011), pp. 2147–2164.