



HAL
open science

On the complexity of Independent Dominant with Obligations in graphs

Christian Laforest, Timothée Martinod

► **To cite this version:**

Christian Laforest, Timothée Martinod. On the complexity of Independent Dominant with Obligations in graphs. [Research Report] LIMOS (UMR CNRS 6158), université Clermont Auvergne, France. 2020. hal-02946979v1

HAL Id: hal-02946979

<https://hal.science/hal-02946979v1>

Submitted on 23 Sep 2020 (v1), last revised 9 Jan 2021 (v2)

HAL is a multi-disciplinary open access archive for the deposit and dissemination of scientific research documents, whether they are published or not. The documents may come from teaching and research institutions in France or abroad, or from public or private research centers.

L'archive ouverte pluridisciplinaire **HAL**, est destinée au dépôt et à la diffusion de documents scientifiques de niveau recherche, publiés ou non, émanant des établissements d'enseignement et de recherche français ou étrangers, des laboratoires publics ou privés.

On the complexity of Independent Dominant with Obligations in graphs

Christian Laforest, Timothée Martinod¹

Laboratoire d'Informatique, de Modélisation et d'Optimisation des Systèmes, Université Clermont Auvergne, CNRS UMR 6158, 63178 Aubière, FRANCE

Abstract

A subset $D \subseteq V$ of a graph $G = (V, E)$ is an independent (or stable) dominant if D is independent and dominates all the vertices of V . An instance of the Independent Dominant with Obligation (*IDO*) problem is a graph $G = (V, E)$ and a partition of V denoted Π (each subset of Π is called an obligation). The distinction is that vertices can only be added obligation by obligation, instead of one by one. In this context D is a solution for (G, Π) if and only if D is an independent dominant respecting these obligations Π . We show that determining if a solution exists for the *IDO* problem is *NP*-complete, even if the graph is a path and all the obligations are stable and are all of size $\lambda \geq 2$, or if there are \sqrt{N} stable obligations each of size \sqrt{N} or if the properties of obligations depend on the number N of vertices of the graph. We further introduce the Partially Independent Dominant with Obligation problem in which we relax the constraint of dominating every vertex. We show that determining if there is a stable set respecting the obligations dominating at least $3\sqrt{N} - 2$ vertices (with N the number of vertices of the graph) is *NP*-complete even if the graph is a path and obligations are stable. On the positive side, we construct in polynomial time a solution dominating at least $2\sqrt{N} - 1$ vertices if obligations are stable.

Keywords: Domination; *NP*-completeness; Non-approximation

1 Introduction

Let G be an undirected graph, with V its set of vertices and E its set of edges. We denote $\mathbb{N}(V_1)$ the open neighborhood of a set of vertices V_1 . $\mathbb{N}(V_1)$ is the set of vertices sharing

This work was sponsored by a public grant overseen by the French National Research Agency as part of the “Investissements d’Avenir” through the IMobS3 Laboratory of Excellence (ANR-10-LABX-0016) and the IDEX-ISITE initiative CAP 20-25 (ANR-16-IDEX-0001).

¹Corresponding author

Email addresses: christian.laforest@uca.fr (Christian Laforest), timothee.martinod@uca.fr (Timothée Martinod)

an edge with at least one vertex of V_1 . Let $D \subseteq V$ be a subset of vertices. D is a stable or independent set of G if there is no edge between vertices of D in G . D is a dominating set of G if each vertex of $V - D$ has at least one neighbor in D . D is an independent dominating set of G if D is a stable and a dominating set of G .

There are many kinds of domination problems according to the properties, namely the independent dominant, the total dominant, the connected dominant, among others (see [7] and [6]). These problems occur in many distributed network applications. The goal is to locate the smallest number of centers in networks such that every vertex is near at least one center. The best known bound for time complexity of the minimum dominating set is $O(1.4969^n)$, where n is the number of vertices in the graph, because of a measure and conquer approach. Van Rooij and Bodlaender got this bound in [10]. The problem of Independent Dominant was first formalized by Berge [2] and Ore [9] in 1962 and 1965. Garey has shown that finding the smallest independent dominating set of a graph is NP -complete [5]. But any graph has at least an independent dominating set. Independent dominating sets have been studied considerably in the literature in the last decades. In 1991 Irving [8] has shown that, unless $P = NP$, no polynomial-time approximation algorithm for this problem can guarantee to find an independent dominating set with size within a factor of K of the optimal, where $K > 1$ is any fixed constant, even in bipartite graphs. In 2004 Chlebík and Chlebíková [3] have shown that it is NP -hard to approximate the independent dominating set problem with a graph of maximal degree three within a $1 + 1/390$ ratio even in bipartite graphs. In 2020 Akbari et al. [1] have provided a family of connected cubic graphs of order n where the minimum cardinality of an independent dominating set is $3n/8$.

In this paper, we consider the independent dominant problem with an additional constraint: the obligations. Obligations are a partition of V . If many vertices are part of the same obligation, when one of them is in a solution all the other ones must also be part of it. In our variant, we can only add vertices obligation by obligation, instead of one by one. An independent Dominant with Obligation (*IDO*) of a graph is an independent dominating set respecting each obligation. If all obligations have the same size, they are denoted balanced. Independent obligations are denoted stable. Since each obligation can contain edges between its elements, there are instances without solution. In all this paper we consider stable obligations.

Independent Dominant with Obligation (*IDO*)

Given: A graph $G = (V, E)$, an obligation-set $\Pi = \{V_1, \dots, V_l\}$ (partition of V).

Objective: A set of vertices $V' \subseteq V$ such that:

- $V' \cup \mathbb{N}_G(V') = V$: V' is a dominating set of G ;
- $\forall v_1, v_2 \in V', (v_1, v_2) \notin E$: V' is a stable of G ;
- $\forall V_i \in \Pi \forall x_j, x_k \in V_i, x_j \in V' \implies x_k \in V'$: V' respects the obligations.

The *IDO* problem was first introduced by Cornet and Laforest in [4]. They proved that determining if a solution exists is *NP*-complete even with obligations of maximal size two². But they used non-stable obligations to forbid some vertices.

In this paper, we prove that determining if a solution exists is *NP*-complete in different cases according to the topology of the graph, the stability and the balance of the obligation-set (see details in Table 1). We also introduce its maximization form in which we relax only the constraint of dominating each vertex. This is the Partially Independent Dominant with Obligation *PIDO* problem. We study this generalization of *IDO* to approach the origin of difficulty of the problem in very restricted cases.

Each result shown in the Table 1 is followed by a reference to its theorem. The symbols $|o|$ and $\#o$ define respectively the size and the number of obligations. λ is a constant and n is the number of vertices of the graph. In case of balanced obligations, we specify its size or number between parentheses. We specify the minimum number of vertices to dominate for the *PIDO* problem between parentheses.

The rest of this paper is organized as follows. In Section 2 we give important definitions. In Section 3 we present a process to connect many connected components, without changing the existence of a solution for the *IDO* problem. This technical preliminary is then used to show that determining if a solution exists for the *IDO* problem is *NP*-complete, even if the graph is a path and the obligations are stable and λ -balanced (all the obligations have a size λ , with $\lambda \geq 2$). In Section 4 we show that the *IDO* problem is *NP*-complete even if there are \sqrt{N} obligations of size \sqrt{N} with N the number of vertices of the graph. We also discuss the complexity if there are less or more stable and balanced obligations. In Section 5 we study the Partially Independent Dominant with Obligation problem, where we relax the constraint of dominating each vertex. We show that determining if there is a solution dominating at least $3\sqrt{N} - 2$ vertices (with N the number of vertices of the graph) is *NP*-complete even if the graph is a path and obligations are stable. However, we construct a solution which can always dominate $2\sqrt{N} - 1$ vertices if obligations are stable. In Section 6 we conclude this paper.

²Note that when obligations are singletons, this matches the classical independent dominant problem.

Problem	Graph	Obligation	Complexity	Theorem
<i>IDO</i>	Path	Stable + balanced ($ o = \lambda \geq 2$)	\mathcal{NPC}	Theorem 3
<i>IDO</i>	Diameter 3	Stable + balanced ($ o = \lambda \geq 2$)	\mathcal{NPC}	Theorem 4
<i>IDO</i>	Any	Stable + balanced ($\#o = \sqrt{n}$)	\mathcal{NPC}	Theorem 5
<i>IDO</i>	Any	Stable + balanced ($n > \#o > \sqrt{n}$)	\mathcal{NPC}	Theorem 6
<i>IDO</i>	Any	Stable + balanced ($\lambda < \#o < \sqrt{n}$)	\mathcal{NPC}	Theorem 7
<i>PIDO</i> ($3\sqrt{n} - 2$)	Collection of paths	Stable	\mathcal{NPC}	Theorem 8
<i>PIDO</i> ($2\sqrt{n} - 1$)	Any	Stable	\mathcal{P}	Theorem 9

Table 1: Synthesis of the results for the existence of a solution for *IDO* and *PIDO*.

2 Preliminaries

We use the standard notation $G = (V, E)$ for graphs, with V its vertices and E its edges. We consider only finite and undirected graphs. The open neighborhood of a vertex v of G is $\mathbb{N}_G(v) = \{u \in V \mid (uv) \in E\}$. A path is a connected graph defined by a sequence of distinct vertices joined by edges. So a collection of paths is a collection of sequences of distinct vertices. It has many connected disjoint components. The distance between two vertices u and v is the length of the shortest path between u and v . The diameter of a graph is the largest distance between its vertices.

Each instance of *IDO* has two inputs: A graph and a partition of its vertices (called an obligation-set).

Let (G, Π) be an instance of *IDO* with $G = (V, E)$ its graph and $\Pi = \{V_1, \dots, V_l\}$ its obligation-set. Let S be a solution. S respects the obligation $V_i = \{x_j, \dots, x_k\} \in \Pi$, if all the vertices of obligation V_i either are in the solution S or are not in the solution S . For each pair of vertices $x_j, x_k \in V_i$, if $(x_j x_k) \notin E$ the obligation is *stable* (or independent). If all obligations are stable, the obligation-set is also *stable*. If $|V_1| = |V_2| = \dots = |V_l| = l$, then the obligation-set is denoted *balanced* or *l-balanced*.

Our proofs of *NP*-completeness will be constructed from the Restricted Exact Cover by 3-Sets problem, which is *NP*-complete (see [5]). Let \mathcal{X} be a finite set of elements and \mathcal{C} a collection of triplets of \mathcal{X} . Each element in \mathcal{X} appears exactly in three subsets of \mathcal{C} . In this restriction of the *X3C* problem there are $3q$ elements and $3q$ triplets. The goal is to decide if there is a subcollection $\mathcal{C}' \subseteq \mathcal{C}$ such that each element in \mathcal{X} occurs in exactly one member of \mathcal{C}' . Such a subcollection has exactly q independent triplets.

Restricted Exact Cover by three Sets ($RX3C$)

Given: A finite set of elements \mathcal{X} , a collection \mathcal{C} of triplets of \mathcal{X} in which each element of \mathcal{X} appears exactly in three subsets.

Objective: A subcollection $\mathcal{C}' \subseteq \mathcal{C}$ such that each element in \mathcal{X} occurs in exactly one member of \mathcal{C}' .

3 IDO in a path

In this section, we show that the IDO problem is NP -complete even in a path with stable and λ -balanced obligations with $\lambda \geq 2$. As we said above, we will do a reduction from the $RX3C$ problem. Since the construction requires using several gadgets, we will proceed step by step. If the obligations have an identifier, their identifier will be useful for the construction. They will refer to the same obligation through multiple constructions. First, each element in $RX3C$ is in exactly three triplets. To represent membership of the elements and the intersection between triplets, we will create one gadget per element.

Construction 1. Let $(\mathcal{X}, \mathcal{C})$ be an instance of $RX3C$ with $\mathcal{X} = \{x_1, \dots, x_{3q}\}$ and $\mathcal{C} = \{c_1, \dots, c_{3q}\}$. We construct $G_{element} = (V_{element}, E_{element})$ a graph and $\Pi_{element}$ its obligations as follows:

- For each $x_i \in \mathcal{X}$:
 - Let $c_j, c_k, c_l \in \mathcal{C}$ with $j < k < l$ be the three triplets containing x_i .
 - We add 16 obligations denoted $y_i^T, y_i^F, y_i^1, \dots, y_i^{11}, x_i^1, x_i^2$ and x_i^3 each composed by two independent vertices. In each obligation y and x we consider that there is one left vertex and one right vertex respectively denoted by $L(y)$ and $R(y)$ or $L(x)$ and $R(x)$.
 - We add the vertices Z_j, Z_k and Z_l .
 - We add the edges $(R(y_i^T)L(y_i^F)), (R(y_i^F)L(y_i^1)), (R(y_i^F)L(y_i^2)), (L(y_i^1)R(y_i^4)), (R(y_i^1)L(y_i^4)), (R(y_i^1)R(y_i^2)), (L(y_i^2)L(y_i^3)), (R(y_i^3)L(y_i^5)), (R(y_i^3)L(y_i^6)), (R(y_i^4)L(y_i^9)), (L(y_i^5)R(y_i^7)), (R(y_i^5)R(y_i^6)), (R(y_i^5)L(y_i^7)), (L(y_i^6)R(y_i^8)), (R(y_i^6)L(y_i^8)), (R(y_i^7)L(y_i^{10})), (R(y_i^8)L(y_i^{11})), (R(y_i^9)L(x_i^1)), (R(y_i^{10})L(x_i^2)), (R(y_i^{11})L(x_i^3)), (R(x_i^1)Z_j), (R(x_i^2)Z_k)$ and $(R(x_i^3)Z_l)$.

Note that $G_{element}$ is a collection of paths, with $48q$ stable 2-balanced (if we except the Z -vertices) obligations. See an illustration on Figure 1. In Construction 1, each triplets is represented by three vertices divided in the gadget of its three elements.

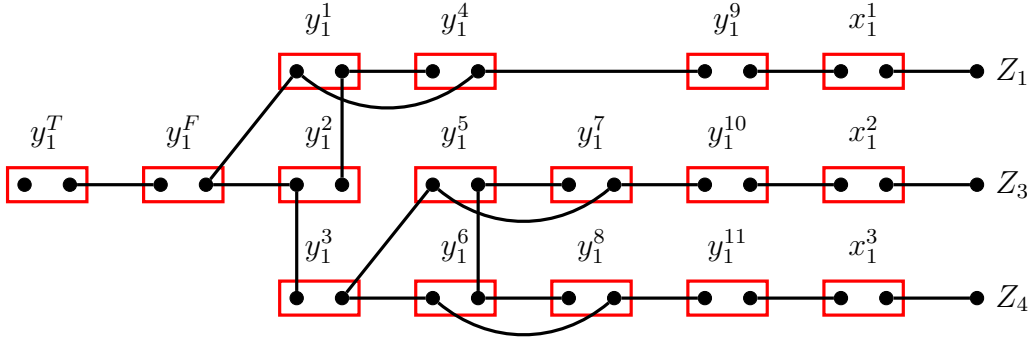

Figure 1: Illustration of Construction 1 only for the element x_1 of the instance $(\mathcal{X}, \mathcal{C})$ of $RX3C$ with $\mathcal{X} = \{1, \dots, 6\}$ and $\mathcal{C} = \{\{1, 2, 3\}, \{2, 3, 4\}, \{1, 2, 6\}, \{1, 5, 6\}, \{3, 4, 5\}, \{4, 5, 6\}\}$.

Lemma 1. *Let $(\mathcal{X}, \mathcal{C})$ be an instance of $RX3C$. Let H be the gadget of the element x_i in the graph following Construction 1 from $(\mathcal{X}, \mathcal{C})$. There is no solution for the IDO problem in H which has neither Z_j , Z_k nor Z_l .*

Proof. Suppose there is a solution S which has neither Z_j , Z_k nor Z_l . So obligations x_i^1 , x_i^2 and x_i^3 must be in S and so must be y_i^4 , y_i^7 , y_i^8 and y_i^3 . Since y_i^T has an isolated vertex, y_i^T is in S and the right vertex of y_i^F has to be dominated by y_i^1 or y_i^2 . However, they cannot be in S because of the two edges $(R(y_i^1)L(y_i^4))$ and $(L(y_i^2)L(y_i^3))$, which is a contradiction. \square

Lemma 2. *Let $(\mathcal{X}, \mathcal{C})$ be an instance of $RX3C$. Let H be the gadget of the element x_i in the graph following Construction 1 from $(\mathcal{X}, \mathcal{C})$. For each vertex Z_j , Z_k or Z_l , there is a solution for the IDO problem in H which has it but not the two others. These solutions are $S_j = \{Z_j, y_i^9, y_i^1, y_i^3, y_i^7, y_i^8, x_i^2, x_i^3, y_i^T\}$, $S_k = \{Z_k, y_i^{10}, y_i^5, y_i^8, y_i^2, y_i^4, x_i^1, x_i^3, y_i^T\}$ and $S_l = \{Z_l, y_i^{11}, y_i^6, y_i^7, y_i^2, y_i^4, x_i^1, x_i^2, y_i^T\}$.*

Lemma 3. *Let $(\mathcal{X}, \mathcal{C})$ be an instance of $RX3C$. Let H be the gadget of the element x_i in the graph following Construction 1 from $(\mathcal{X}, \mathcal{C})$. There is no solution for the IDO problem in H which has more than one vertex among Z_j , Z_k and Z_l .*

Proof. Suppose there is a solution S containing Z_k and Z_l . Since Z_k and Z_l are in S , y_i^{10} and y_i^{11} must be in S . So, S must contain y_i^5 and y_i^6 which is a contradiction because of the edge between $R(y_i^5)$ and $R(y_i^6)$.

Suppose there is a solution S containing Z_j and one vertex among Z_k and Z_l . Since $Z_k \in S$ or $Z_l \in S$, either $\{y_i^{10}, y_i^5, y_i^2\} \in S$ or $\{y_i^{11}, y_i^6, y_i^2\} \in S$. Since $Z_j \in S$, y_i^9 and y_i^1 must be in S , which is a contradiction because of the edge between $R(y_i^1)$ and $R(y_i^2)$. \square

We can conclude that each gadget representing an element x_i admits a solution for the IDO problem if and only if there is exactly one vertex in the solution representing the triplets, which contain x_i .

Each triplet is represented by three vertices in Construction 1. However, if one copy is in the solution, then all the other copies must also be in the solution. So, we connect these copies in one gadget per triplet.

Construction 2. Let $(\mathcal{X}, \mathcal{C})$ be an instance of $RX3C$ with $\mathcal{X} = \{x_1, \dots, x_{3q}\}$ and $\mathcal{C} = \{c_1, \dots, c_{3q}\}$. We construct $G = (V, E)$ a graph and Π its obligations as follows:

- We follow Construction 1.
- For each three vertices Z_i arbitrarily defined as Z_i^a, Z_i^b and Z_i^d :
 - We add three 2-balanced obligations z_i^a, z_i^b and z_i^d which contain respectively Z_i^a, Z_i^b, Z_i^d and a new vertex in each, respectively denoted $R(z_i^a), R(z_i^b)$ and $R(z_i^d)$.
 - We add three 2-balanced obligations y_i^{12}, y_i^{13} and y_i^{14} composed of two independent vertices. In each obligation y we consider that there is one left vertex and one right vertex respectively represented by $L(y)$ and $R(y)$.
 - We add the edges $(R(z_i^a)L(y_i^{12})), (R(z_i^b)L(y_i^{12})), (R(z_i^d)L(y_i^{14})), (R(y_i^{12})L(y_i^{13}))$ and $(R(y_i^{13})R(y_i^{14}))$.

Note that G is a collection of paths, with $66q$ stable 2-balanced obligations. See two illustrations on Figure 2 and Figure 3. Figure 2 shows the gadget used for each triplet of \mathcal{C} . In Figure 3 each ellipse represents the gadget of an element, and each pentagon represents the gadget of a triplet.

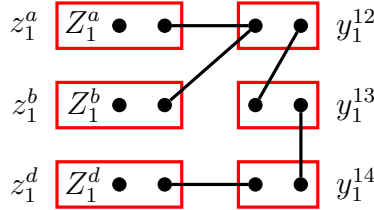

Figure 2: Illustration of Construction 2 for the triplet c_1 of the instance $(\mathcal{X}, \mathcal{C})$ of $RX3C$ with $\mathcal{X} = \{1, \dots, 6\}$ and $\mathcal{C} = \{\{1, 2, 3\}, \{2, 3, 4\}, \{1, 2, 6\}, \{1, 5, 6\}, \{3, 4, 5\}, \{4, 5, 6\}\}$.

Lemma 4. Let $(\mathcal{X}, \mathcal{C})$ be an instance of $RX3C$. Let G be the graph following Construction 2 from $(\mathcal{X}, \mathcal{C})$. Let H be the gadget of the triplet c_i from G . An obligation z_i in H is in a solution S for the IDO problem in G if and only if the two others are in the solution S .

Proof. We know that the Z_i vertices can be dominated by a vertex in $G \setminus H$. Let S be a solution for G . Consider the two following cases: The obligation $y_i^{13} \in S$ or $y_i^{13} \notin S$.

Suppose that the obligation y_i^{13} is in S . The obligations y_i^{12} and y_i^{14} cannot be in S . So, S have still one vertex to dominate in each. So, the obligations z_i^a and z_i^d must be in

S . Since $L(y_i^{12})$ cannot dominate $R(z_i^b)$, the obligation z_i^d must be in S . Thus, all the z_i obligations are in S .

Suppose now that the obligation y_i^{13} is not in S . The obligations y_i^{12} and y_i^{14} must be in S . Thus, no z_i obligations can be in S .

In both cases, either all the z_i obligations are in S or none. \square

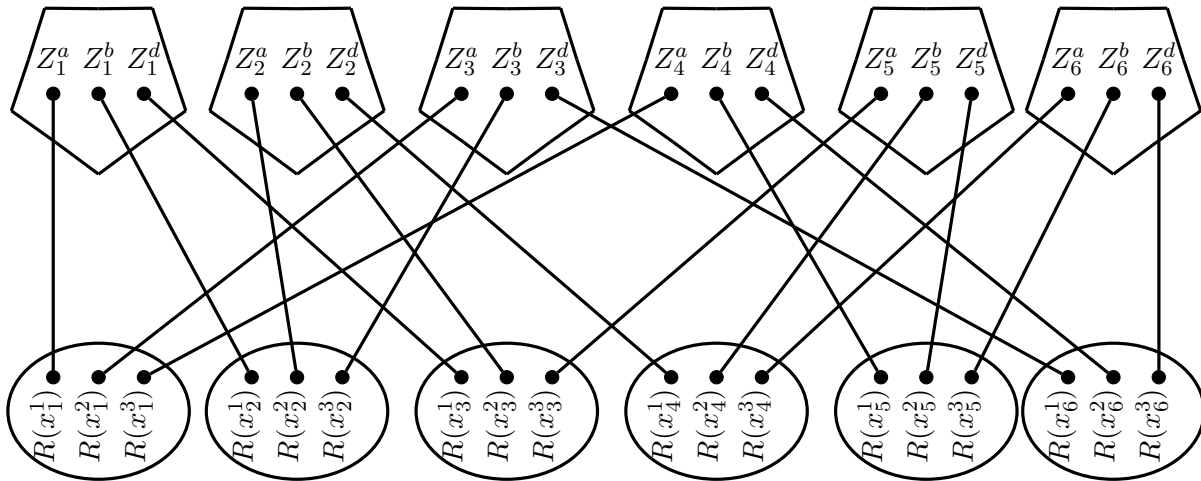

Figure 3: Illustration of Construction 2 for the instance $(\mathcal{X}, \mathcal{C})$ of $RX3C$ with $\mathcal{X} = \{1, \dots, 6\}$ and $\mathcal{C} = \{\{1, 2, 3\}, \{2, 3, 4\}, \{1, 2, 6\}, \{1, 5, 6\}, \{3, 4, 5\}, \{4, 5, 6\}\}$. Pentagons represent gadgets like in Figure 2. Ellipses represent gadgets like the ones in Figure 1.

Theorem 1. *Determining if a solution exists for the IDO problem is NP-complete, even if the graph is a collection of paths and the obligations are stable and 2-balanced.*

Proof. The problem is clearly in NP.

Suppose there is a solution S for the instance $(\mathcal{X}, \mathcal{C})$ of $RX3C$. Let us construct a solution S' for the IDO problem. For each $c_i \in S$ we put the obligations z_i^a, z_i^b, z_i^d and y_i^{13} in S' . For each $c_i \notin S$ we put the obligations y_i^{12} and y_i^{14} in S' . For each $Z_i \in S'$, we add in the solution the well-chosen vertices following Lemma 2. S' respects the obligations, is stable and dominates all the vertices. S' is a solution for the IDO problem.

Suppose there is a solution S for the instance G, Π of IDO. Let us construct a solution S' for the $RX3C$ problem. For each $Z_i \in S, c_i \in S'$. Since each element is covered by at least one triplet (see Lemma 1) and at most one triplet (see Lemma 3), S' is a solution for the $RX3C$ problem. \square

We can extend Theorem 1 for λ -balanced obligations with $\lambda \geq 2$ a constant integer. The general idea is the following (details are given later): If λ is even, then we duplicate all the instances (graph and obligations) $\frac{\lambda-2}{2}$ times and merge the copies. If λ is odd, the following construction adds one vertex in each obligation while keeping the property of the previous lemmas and theorem.

Construction 3. Let $(\mathcal{X}, \mathcal{C})$ be an instance of $RX3C$ with $\mathcal{X} = \{x_1, \dots, x_{3q}\}$ and $\mathcal{C} = \{c_1, \dots, c_{3q}\}$. We construct $G = (V, E)$ a graph and its obligations Π as follows:

- We follow Construction 2.
- For each $x_i \in \mathcal{X}$:
 - In each obligation y_i (except y_i^{12} , y_i^{13} and y_i^{14}) and x_i we add a new vertex denoted respectively $N(y_i)$ or $N(x_i)$.
 - We add the edges $(N(y_i^T)N(y_i^F))$, $(N(y_i^1)N(y_i^2))$, $(N(y_i^1)N(y_i^4))$, $(N(y_i^3)N(y_i^5))$, $(N(y_i^3)N(y_i^6))$, $(N(y_i^5)N(y_i^7))$, $(N(y_i^6)N(y_i^8))$, $(N(y_i^9)N(x_i^1))$, $(N(y_i^{10})N(x_i^2))$ and $(N(y_i^{11})N(x_i^3))$.
- For each $c_i \in \mathcal{C}$:
 - In each obligation y_i^{12} , y_i^{13} , y_i^{14} or z_i we add a new vertex denoted respectively $N(y_i^{12})$, $N(y_i^{13})$, $N(y_i^{14})$ or $N(z_i)$.
 - We add the edges $(N(y_i^{12})N(z_i^a))$, $(N(y_i^{12})N(z_i^b))$, $(N(y_i^{14})N(z_i^d))$ and $(N(y_i^{14})N(y_i^{13}))$.

Note that G is a collection of paths, with $66q$ stable 3-balanced obligations. See two illustrations on Figure 4 and Figure 5. The obligations represented on Figure 4 and Figure 5 are the same than on Figure 1 and Figure 2, but only the vertices and edges added by Construction 3 are shown. In other words, all the obligations has both vertices of Construction 1 (respectively Construction 2) and vertices of Construction 3.

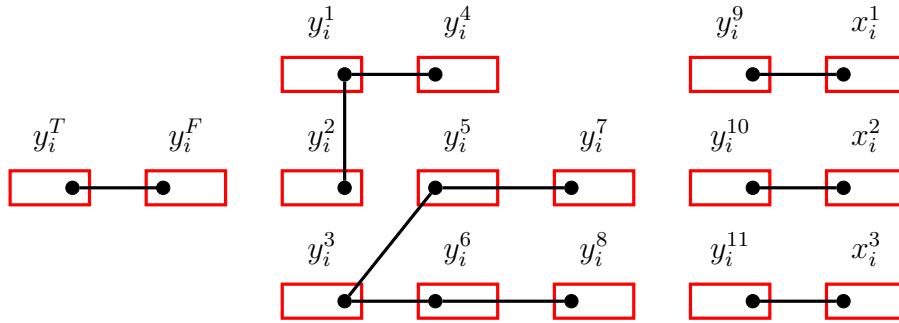

Figure 4: Illustration of Construction 3 only for the element x_i of the instance $(\mathcal{X}, \mathcal{C})$ of $RX3C$ with $\mathcal{X} = \{1, \dots, 6\}$ and $\mathcal{C} = \{\{1, 2, 3\}, \{2, 3, 4\}, \{1, 2, 6\}, \{1, 5, 6\}, \{3, 4, 5\}, \{4, 5, 6\}\}$.

In Construction 4 we "merge" some instances with obligations which share the same identifier (the same order) into one instance. Given $\Pi^k = V_1^k, \dots, V_l^k$ with $1 \leq k \leq i$, merge i -th instances $(G^1, \Pi^1), \dots, (G^i, \Pi^i)$ for the IDO problem in instance (G, Π) is to construct the instance as follows:

- $V(G) = \cup_{k=1}^i (V(G^k))$.

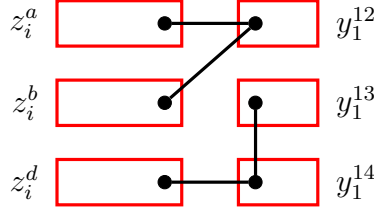

Figure 5: Illustration of Construction 3 only for the triplet z_i of the instance $(\mathcal{X}, \mathcal{C})$ of $RX3C$ with $\mathcal{X} = \{1, \dots, 6\}$ and $\mathcal{C} = \{\{1, 2, 3\}, \{2, 3, 4\}, \{1, 2, 6\}, \{1, 5, 6\}, \{3, 4, 5\}, \{4, 5, 6\}\}$.

- $E(G) = \cup_{k=1}^i (E(G^k))$.
- For each obligation $V_j \in \Pi = \{V_1, \dots, V_l\}$, $V_j = \cup_{k=1}^i (V_j^k)$.

Construction 4. Let $(\mathcal{X}, \mathcal{C})$ be an instance of $RX3C$ with $\mathcal{X} = \{x_1, \dots, x_{3q}\}$ and $\mathcal{C} = \{c_1, \dots, c_{3q}\}$. Let $\lambda \geq 2$ be an integer. We construct $G = (V, E)$ a graph and Π its obligations as follows:

- If λ is even: we duplicate Construction 2 $\frac{\lambda}{2}$ times and merge the copies.
- If λ is odd:
 - We follow Construction 3.
 - We duplicate Construction 2 $\frac{\lambda-3}{2}$ times. We merge the $\frac{\lambda-3}{2}$ copies with the graph of the previous step.

Note that G is a collection of paths, with $66q$ stable λ -balanced obligations.

Since Construction 4 obviously does not affect the solutions, we can state the following theorem.

Theorem 2. Determining if a solution exists for the IDO problem is NP-complete, even if the graph is a collection of paths and the obligations are stable and λ -balanced with $\lambda \geq 2$ a constant integer.

We can extend Theorem 2 to paths with stable and λ -balanced obligations with $\lambda \geq 2$ a constant integer. To do so, we introduce a new gadget: The neutral connector.

Definition 1. A neutral connector for IDO is a graph that connects two connected components such that a solution exists for IDO in the reconnected graph if and only if there is a solution in each component.

Construction 5. We construct a graph $G_{neutral} = (V_{neutral}, E_{neutral})$ and its obligations $\Pi_{neutral}$ as follows:

- We add a path $Q_1, \dots, Q_{3\lambda}$.

- We add three obligations V_1, V_2 and V_3 .
- We add $Q_1, Q_3, Q_{3\lambda-3}$ in V_1 , $Q_2, Q_{3\lambda-1}$ in V_2 and $Q_4, Q_{3\lambda-2}, Q_{3\lambda}$ in V_3 .
- For each vertex $Q_i \in \{Q_5, \dots, Q_{3\lambda-4}\}$:
 - If $i \pmod{3} = 0$, we add Q_i in V_1 .
 - If $i \pmod{3} = 2$, we add Q_i in V_2 .
 - If $i \pmod{3} = 1$, we add Q_i in V_3 .

Note that $G_{neutral}$ is a path, with three stable λ -balanced obligations. See an illustration on Figure 6 and Figure 7.

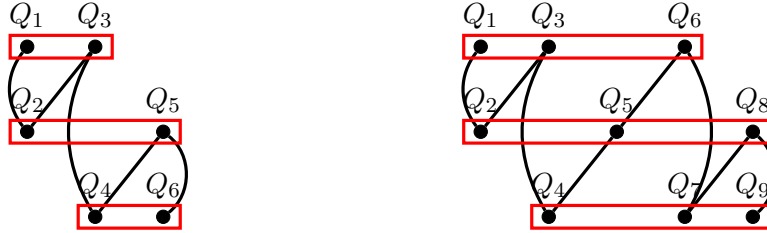

Figure 6: A neutral connector following Construction 5 with $\lambda = 2$ on the left and $\lambda = 3$ on the right.

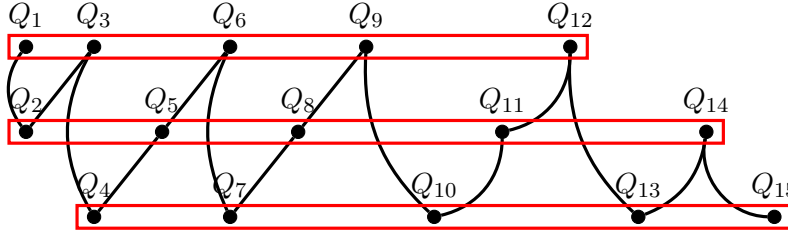

Figure 7: A neutral connector following Construction 5 with $\lambda = 5$.

We will show that all the paths following Construction 5 is a neutral connector for the *IDO* problem.

Lemma 5. *Let $\lambda \geq 2$ be an integer. The path $G_{neutral}$ from Construction 5 is a neutral connector for the *IDO* problem, with λ -balanced stable obligations.*

Proof. Let $G_{neutral}$ be a graph from Construction 5, with its obligations $\Pi_{neutral}$. We show that there is only one solution for the *IDO* problem.

Suppose that the obligation V_1 is in a solution. All the other obligations cannot be in that solution because of conflicts from edges. There is no solution to dominate the vertex $Q_{3\lambda-1}$, even if the path is connected to another graph by its vertices Q_1 and $Q_{3\lambda}$. The

argument is exactly the same for the obligation V_3 . There is no solution to dominate the vertex Q_2 .

Suppose that the obligation V_2 is in a solution. The solution is independent and dominates all the vertices of $G_{neutral}$. The vertices Q_1 and $Q_{3\lambda}$ are not in the solution. If the path is connected to another graph by its vertices Q_1 and $Q_{3\lambda}$, a solution exists in the global graph if and only if there is simultaneously a solution in the two subgraphs respectively connected to the vertices Q_1 and $Q_{3\lambda}$.

Thus, $G_{neutral}$ is a neutral connector for IDO . □

To get a path with stable and λ -balanced obligations, with $\lambda \geq 2$ an integer constant, we connect all disjoint paths of the graph got after Construction 4. While there are over one path, we take two disjoint paths P_i and P_j . Let v_i and v_j respectively be one extremity of P_i and P_j . Let $G_{neutral}$ be a new neutral connector following Construction 5. We connect v_i to Q_1 of $G_{neutral}$ and v_j to $Q_{3\lambda}$ of $G_{neutral}$. Since the connectors are neutrals, we can connect the components in any order. There is only one constraint. The components must be connected by the extremities of their paths.

Now, we can state the following theorem.

Theorem 3. *Determining if a solution exists for the IDO problem is NP -complete, even if the graph is a path and the obligations are stable and λ -balanced, with $\lambda \geq 2$ an integer constant.*

In addition, the IDO problem is NP -complete even if the graph has a low or high density of edges. We can add independent vertices or complete graphs with singleton obligations. Thus we do not give the proof.

We show now that the IDO problem is NP -complete even in a graph of diameter 3 with stable and λ -balanced obligations, with $\lambda \geq 2$ an integer constant.

Construction 6. *Let $(\mathcal{X}, \mathcal{C})$ be an instance of $RX3C$ with $\mathcal{X} = \{x_1, \dots, x_{3q}\}$ and $\mathcal{C} = \{c_1, \dots, c_{3q}\}$. Let $\lambda \geq 2$ be an integer. We construct $G = (V, E)$ a graph and Π its obligations as follows:*

- *We follow Construction 4.*
- *We add a neutral connector following Construction 5 with obligations of size λ .*
- *We add λ new vertices and their obligation $\Lambda = \{v_1, \dots, v_\lambda\}$.*
- *We add an edge between $\{v_1, \dots, v_\lambda\}$ and all the vertices of the other obligations except Q_3 of the neutral connector.*

Note that G is a graph of diameter 3, with $68q$ stable λ -balanced obligations. See an illustration on Figure 8.

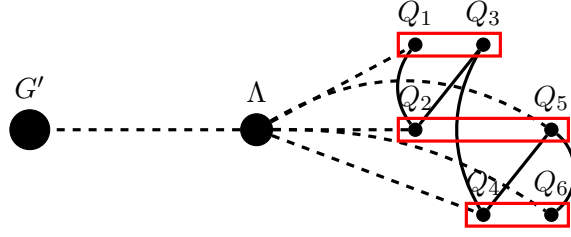

Figure 8: A graph following Construction 6 with $\lambda = 2$, and G' the rest of the graph.

Theorem 4. *Determining if a solution exists for the IDO problem is NP-complete, even if the graph is of diameter 3 and the obligations are stable and λ -balanced, with $\lambda \geq 2$ an integer constant.*

Proof. Each vertex of $V \setminus (Q_3 \cup \Lambda)$ has a distance 1 to vertices of Λ . Each vertex of Λ has a distance 2 to other vertices of Λ . The vertex Q_3 has a distance 2 to all the vertices of Λ . Thus, the graph has a diameter 3.

The vertices $\{v_1, \dots, v_\lambda\}$ cannot be in a solution. If there are in a solution, the vertex Q_3 of the neutral connector cannot be dominated. However, the others vertices of the graph always dominate the vertices $\{v_1, \dots, v_\lambda\}$. Since the new vertices do not affect the solution in the collection of paths following Construction 4, the proof does not differ. \square

Since the IDO problem is NP-complete even in the very restricted case where the graph is a path, and the obligations are stable λ -balanced with $\lambda \geq 2$, we will study the difficulty of the problem according to the size and the number of obligations.

4 IDO with balanced obligations

In this section, we show that the IDO problem is NP-complete even if the number of obligations is proportionally low or high. As in the previous section, we will do a reduction from the RX3C problem. Firstly, we propose another construction to solve the RX3C problem with an instance of IDO. This construction, easier than the earlier one of Section 3, will be useful later to prove the next results.

Construction 7. *Let $(\mathcal{X}, \mathcal{C})$ be a instance of RX3C with $\mathcal{X} = \{x_1, \dots, x_{3q}\}$ et $\mathcal{C} = \{c_1, \dots, c_{3q}\}$. We construct a graph $G = (V, E)$ and its obligations Π as follows:*

- *For each $x_i \in X$, we add the vertex x_i .*
- *For each $c_i \in C$, we add the vertex z_i .*
- *For each $c_i \neq c_j \in C$, if c_i and c_j share at least one element then we add the edge $(z_i z_j)$.*

- For each $c_i = \{x_j, x_k, x_l\} \in C$, we add the edges $(z_i x_j)$, $(z_i x_k)$ and $(z_i x_l)$.
- We add the vertices y_1 , y_2 and y_3 , and the edge $(y_1 y_2)$.
- We add the obligations $\{x_1, \dots, x_{3q}, y_1\}$ and $\{y_2, y_3\}$.
- Each other vertex is in an obligation of size one.

Note that G is a graph, with $6q + 3$ vertices and $3q + 2$ stable obligations. See an illustration on Figure 9.

The instance of *IDO* following Construction 7 only uses stable obligations. They are not balanced.

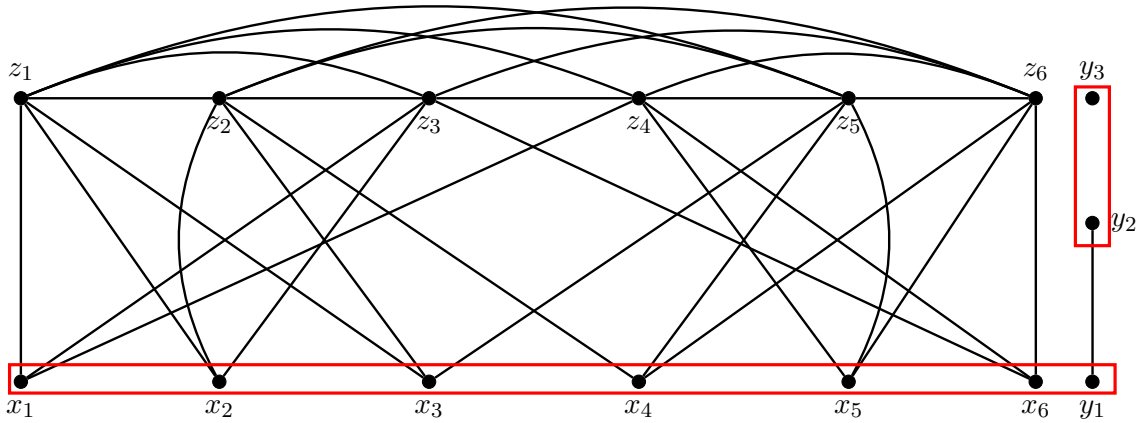

Figure 9: Illustration of Construction 7 for the instance $(\mathcal{X}, \mathcal{C})$ of *RX3C* with $\mathcal{X} = \{1, \dots, 6\}$ and $\mathcal{C} = \{\{1, 2, 3\}, \{2, 3, 4\}, \{1, 2, 6\}, \{1, 5, 6\}, \{3, 4, 5\}, \{4, 5, 6\}\}$.

Lemma 6. *Let $(\mathcal{X}, \mathcal{C})$ be an instance of *RX3C*. A solution exists if and only if there is a solution for the *IDO* problem following Construction 7 from $(\mathcal{X}, \mathcal{C})$.*

Proof. Suppose that there is a solution S for the instance $(\mathcal{X}, \mathcal{C})$ of *RX3C*, with $\mathcal{X} = \{x_1, \dots, x_{3q}\}$ and $\mathcal{C} = \{c_1, \dots, c_{3q}\}$. Let us construct S' a solution for the instance (G, Π) following Construction 7. For each $c_i \in S$, we put $z_i \in S'$. All of the Z -vertices and x -vertices are dominated by an independent subset of the graph. Finally, we put the vertices y_2 and y_3 in S' . Thus S' is independent, dominates all the vertices of the graph, and respects the obligations. Thus, S' is a solution for *IDO*.

Suppose that there is a solution S of *IDO* for the instance (G, Π) from Construction 7. Let us construct S' a solution for the instance $(\mathcal{X}, \mathcal{C})$ of *RX3C*. Vertex y_3 can only be dominated by itself. Thus obligation $\{y_2, y_3\}$ is in S and then no x -vertex can be in S , so they are dominated by the Z -vertices. Since S is independent, each x -vertex is dominated by exactly one Z -vertex. For each $z_i \in S$, we put $c_i \in S'$. Thus, S' is a solution for *RX3C*. \square

We can now change Construction 7 to get the property required on the obligations. Let us start with \sqrt{N} stable and \sqrt{N} -balanced obligations, with N the number of vertices of the graph.

Construction 8. Let $(\mathcal{X}, \mathcal{C})$ be an instance of *RX3C* with $\mathcal{X} = \{x_1, \dots, x_{3q}\}$ and $\mathcal{C} = \{c_1, \dots, c_{3q}\}$. We construct a graph $G = (V, E)$ and its obligations Π as follows:

- We add the vertices, the edges and the obligations following Construction 7.
- We add the new vertices y^4, \dots, y^{3q+3} to the obligation which contains $\{y_2, y_3\}$.
- We add the vertex y'_1 to the obligation which contains y_1 and the edge $(y'_1 y_2)$.
- For each $z_i \in V$, we add the new vertices z_i^1, \dots, z_i^{3q+1} in the obligation which contains z_i .
- For each $z_i \neq z_j \in V$, we add the edges $(z_i^1 z_j), \dots, (z_i^{3q+1} z_j)$ if and only if $(z_i z_j) \in E$.

Note that G has $9q^2 + 12q + 4$ vertices and $3q + 2$ stables $3q + 2$ -balanced obligations.

Theorem 5. *Determining if there is a solution for the IDO problem is NP-complete even if there are \sqrt{N} stable and \sqrt{N} -balanced obligations, with N the number of vertices of the graph.*

Proof. Note that G has $N = 9q^2 + 12q + 4$ vertices, and the $3q + 2 = \sqrt{N}$ obligations are all independent and all of size $3q + 2 = \sqrt{N}$. Since the transformation of Construction 7 does not affect the existence of a solution, the proof of Lemma 6 is still valid for Construction 8. \square

With Construction 8 we have constructed an instance of the *IDO* problem with \sqrt{N} stable and \sqrt{N} -balanced obligations. Now we propose a generalization for the number of balanced obligations within two changes. One for less obligations than \sqrt{N} , and the other for more obligations than \sqrt{N} .

Firstly let us see the case of more balanced obligations. We take Construction 8 and add a new stable obligation with the same number of vertices than the others obligations. This new obligation has no edge. Then this instance newly defined has strictly more than \sqrt{N} balanced obligations. We can add a lot of stable obligations like above without affecting the solution in the instance's part following Construction 8. After that, the instance has $\frac{\mathbf{N}}{3q+2}$ stable $(3q + 2)$ -balanced obligations with \mathbf{N} the number of vertices. \mathbf{N} is arbitrary bigger than the size of the obligations. However, the ratio cannot leads to \mathbf{N} stable and balanced obligations unless $P = NP$. When there are as many obligations as vertices, we have a formulation of the classical independent dominant problem which has always a solution dominating all the vertices. This construction leads to the following theorem.

Theorem 6. *Determining if there is a solution for the IDO problem is NP -complete even if there are at least \sqrt{N} (and less than N) stable and balanced obligations, with N the number of vertices of the graph.*

Now let us see the case of balanced obligations with more than \sqrt{N} vertices in each obligation. We take Construction 8 and add a new vertex in each obligation. The new vertex in the same obligation than y_3 (respectively y_1) is stable (respectively connect to y_2). The new z'_1, \dots, z'_{3q} vertices in the same obligations than the z_i -vertices have the same edges than the vertices in their obligations. For example, if there is the edge $(z_1 z_2)$ then there are the edges $(z'_1 z'_2)$ and $(z_1 z'_2)$. Then this instance newly defined has strictly more than \sqrt{N} vertices in each balanced obligation. We can add a lot of vertices in each obligation like above without affect the solution in the instance's part following Construction 8. After that, the instance has $(3q + 2)$ stable $(\frac{N}{3q+2})$ -balanced obligations with N the number of vertices. N is arbitrary bigger than the number of the obligations. This construction leads to the following theorem.

Theorem 7. *Determining if there is a solution for the IDO problem is NP -complete even if there are at most \sqrt{N} stable and balanced obligations, with N the number of vertices of the graph.*

Note that when the number of obligations is independent of N , the IDO problem admits a polynomial algorithm to decide if there is a solution. An algorithm can try all combinations of obligations in polynomial time regarding the number of vertices of the graph ($O(2^{\#o})$ with $\#o$ the number of obligations).

5 Maximizing the number of dominated vertices

Since determining if there is a solution for the IDO problem is NP -complete, even if the instance is a path with stable and λ -balanced obligations (with $\lambda \geq 2$ a constant integer) or whether the stable and balanced obligations are numerous, we relax the constraint of dominating each vertex. We introduce the Partially Independent Dominant with Obligation problem ($PIDO$). Like the IDO problem, an instance of the $PIDO$ problem is a graph and its obligations. The aim of the $PIDO$ problem is to determine the maximal number of vertices that an independent subset respecting the obligations can dominate. We consider the decision version of the $PIDO$ problem. The existence of a solution for an instance depends on the number of vertices to dominate. Since there are instances of the $PIDO$ problem admitting no solution no matter the number of vertices to dominate, because of non stable obligations, we will only consider instances with stable obligations.

Partially Independent Dominant with Obligation (*PIDO*)

Given: A graph $G = (V, E)$, an obligation-set $\Pi = \{V_1, \dots, V_l\}$.

Objective: A set of vertices $V' \subseteq V$ such that:

- $\forall v_1, v_2 \in V', (v_1, v_2) \notin E$: V' is a stable of G ;
- $\forall V_i \in \Pi \forall x_j, x_k \in V_i, x_j \in V' \implies x_k \in V'$: V' respects the obligations.

Measure: $|V' \cup N(V')|$: the number of vertices of G dominated by V' .

In this section, we show that determining if there is a solution for the *PIDO* problem which dominates at least $3\sqrt{N} - 2$ vertices (with N the number of vertices of the graph) is *NP*-complete even if the graph is a collection of paths and the obligations are stable. Unlike the previous sections, we will do a reduction from the *IDO* problem. We will also show that there is always a solution which dominates at least $2\sqrt{N} - 1$ vertices if the obligations are stable. We propose a polynomial algorithm to construct such a solution.

The first step of the proof of *NP*-completeness is to construct the gadget that will allow us to limit the potential domination.

Construction 9. Let Y be an integer. We construct $G_Y = (V_Y, E_Y)$ a graph and Π_Y its obligations as follows:

- We add the vertices $Y_1^1, \dots, Y_Y^1, \dots, Y_1^Y, \dots, Y_Y^Y$.
- We add the obligations $\{Y_1^1, \dots, Y_1^Y\}, \dots, \{Y_Y^1, \dots, Y_Y^Y\}$.
- For each $1 \leq i \neq j \leq Y$, we add the edge $(Y_i^j Y_j^i)$.
- We delete the vertices $Y_1^1, Y_2^2, \dots, Y_{Y-1}^{Y-1}, Y_Y^Y$.

Note that G_Y is a collection of paths with $Y^2 - Y$ vertices and Y stable obligations of size $Y - 1$. See an illustration on Figure 10.

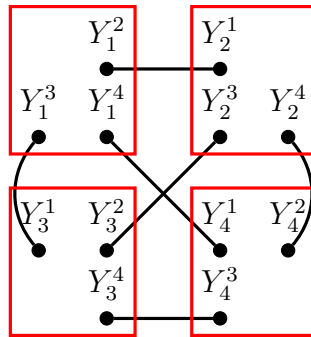

Figure 10: Illustration of Construction 9 for $Y = 4$.

Lemma 7. *Regardless of the value of $Y \geq 2$, it is impossible to dominate more than $2Y - 2$ vertices in the instance (G_Y, Π_Y) of *PIDO* following Construction 9.*

Proof. Let (G_Y, Π_Y) be an instance of *PIDO*, with $Y \geq 2$ an integer, following Construction 9. Since a solution must respect the obligations, let us consider any obligation $V_i \in \Pi_Y$. Let $V_i = \{Y_i^1, \dots, Y_i^Y\}$. Suppose $\{Y_i^1, \dots, Y_i^Y\} \subseteq S$, with S any solution. Because of the structure of the previous construction, there is an edge between V_i and all the other obligations. Thus, no more vertex can be added to S which has $Y - 1$ vertices. These vertices share an edge with $Y - 1$ unique other vertices. So, S dominates exactly $2Y - 2$ vertices.

We can note that it is always possible to dominate at least $2Y - 2$ vertices. \square

We can use the graph following Construction 9, to limit the number of vertices which can be dominated. We will consider an instance of *IDO*, adding this gadget with a well-chosen parameter Y .

Construction 10. *Let (G, Π) be an instance of *IDO* with $G = (V, E)$ a path of n vertices and $\Pi = \{V_1, \dots, V_l\}$ its stable obligations. We construct a graph $G' = (V', E')$ and its obligations Π' as follows:*

- *Let (G_Y, Π_Y) be an instance of *IDO* following Construction 9 with $Y = |V| = n$.*
- *$G' = G \cup G_Y$, $\Pi' = \Pi \cup \Pi_Y$.*

Note that G' is a collection of paths with n^2 vertices, and stable obligations.

Theorem 8. *Determining if there is a solution for the *PIDO* problem which can dominate at least $3\sqrt{N} - 2$ vertices (with N the number of vertices of the graph) is *NP*-complete even if the graph is a collection of paths and the obligations are stable.*

Proof. The problem is clearly in *NP*.

Suppose that there is a solution S for the instance (G, Π) of *IDO*, with stable obligations and $G = (V, E)$ a path. Let us construct S' a solution for the instance (G', Π') of *PIDO* following Construction 10. We can simply take the vertices of S and add one Y -obligation to dominate at least $3\sqrt{N} - 2$ vertices.

Suppose that there is a solution S for the instance (G', Π') of *PIDO* following Construction 10. Let us construct S' a solution for the instance (G, Π) of *IDO*. Since the G_Y part of G' can only dominates $2\sqrt{N} - 2$ vertices, S' must dominate all the vertices of the other part G . Thus there is a solution for the *IDO* problem in G . \square

We have shown that determining if there is a solution for the *PIDO* problem which can dominate at least $3\sqrt{N} - 2$ vertices (with N the number of vertices of the graph) is *NP*-complete even if the graph is a collection of paths and the obligations are stable. On the other side, we can investigate the polynomial threshold. We show that if the obligations

are stable, there is always a solution which dominates at least $2\sqrt{N} - 1$ vertices, with N the number of vertices of the graph. Moreover, such a solution can be constructed in polynomial time.

Firstly, let us consider the following greedy algorithm for the *PIDO* problem:

1. We create an empty solution S .
2. While there are obligations, do:
 - (a) Add the biggest obligation in S .
 - (b) Delete this obligation, the vertices which share an edge with at least one of its vertices, and the obligations of these vertices.
3. Return S .

Note that S has at least one obligation, dominates at least one vertex of every obligation, respects the obligations and is independent. Since the number of obligation strictly decrease at each step of the loop, the algorithm is finite. As there are at most n obligations, with n the number of vertices of the graph, the algorithm is polynomial.

Lemma 8. *Let (G, Π) be an instance of *PIDO* with stable obligations and N the number of vertices of the graph. There is always a solution which can dominate $2\sqrt{N} - 1$ vertices. The greedy polynomial algorithm described above can construct this solution.*

Proof. Let (G, Π) be an instance of *PIDO*, with stable obligations and n the number of vertices of the graph. Let $\#o$ be the number of obligations and $|o|_{max}$ the size of the biggest obligation. The greedy algorithm described above creates a stable set of vertices, respecting obligations and dominating at least $\#o + |o|_{max} - 1$ vertices. We also have the inequality $\#o \times |o|_{max} \geq n$. Because of the inequality, we have either $\#o \geq \sqrt{n}$ or $|o|_{max} \geq \sqrt{n}$. We can use the argument below, in both cases. Let us suppose that $|o|_{max} \geq \sqrt{n}$. We can rewrite this inequality to $|o|_{max} = \sqrt{n} + x$, with x a positive integer. Suppose that $\#o + |o|_{max} < 2\sqrt{n}$:

$$\#o + |o|_{max} < 2\sqrt{n} \tag{1}$$

$$\#o + \sqrt{n} + x < 2\sqrt{n} \tag{2}$$

$$\#o < \sqrt{n} - x \tag{3}$$

Here, we have a contradiction between $\#o \times |o|_{max} \leq (\sqrt{n} - x)(\sqrt{n} + x) \leq n - x^2$ and $\#o \times |o|_{max} \geq n$. Thus we have $\#o + |o|_{max} \geq 2\sqrt{n}$, and so $\#o + |o|_{max} - 1 \geq 2\sqrt{n} - 1$. \square

We can note that the proof of Lemma 8 shows that there is a solution for every instance of the *PIDO* problem which dominates at least $2\sqrt{N} - 1$ vertices. The earlier greedy polynomial algorithm gives this solution. However, we show that there are instances in which it is impossible to dominate more vertices.

Construction 11. Let Y be an integer. We construct $G = (V, E)$ a graph and Π its obligations as follows:

- We add the vertices $v_1^1, \dots, v_Y^1, \dots, v_1^Y, \dots, v_Y^Y$.
- We add the obligations $\{v_1^1, \dots, v_1^Y\}, \dots, \{v_Y^1, \dots, v_Y^Y\}$.
- For each $1 \leq i \neq j \leq Y$, we add the edge (v_i^j, v_j^i) .

Note that G is a collection of paths, with stable and Y -balanced obligations. See an illustration on Figure 11.

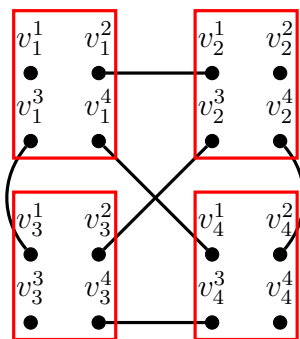

Figure 11: Illustration of Construction 11 with $Y = 4$.

Lemma 9. Regardless of the value of $Y \geq 2$, it is impossible to dominate more than $2\sqrt{N} - 1$ vertices in the instance (G, Π) of $PIDO$ following Construction 11.

Proof. Let (G, Π) be an instance of $PIDO$, with n the number of vertices of the graph, following Construction 11. Since each obligation shares exactly one edge with each other obligation, only one obligation can be in a solution. Since each obligation has \sqrt{n} vertices and there are \sqrt{n} obligations, the solution has exactly $2\sqrt{n} - 1$ vertices, regardless of the chosen obligation. \square

We have shown that there is always a solution which dominates $2\sqrt{N} - 1$ vertices (with N the number of vertices of the graph) for the $PIDO$ problem if the obligations are stable. We have also shown that there are instances in which no more than $2\sqrt{N} - 1$ vertices can be dominated. So, we can conclude this section by the following theorem.

Theorem 9. Let (G, Π) be an instance of $PIDO$ with stable obligations and N be the number of vertices of the graph. There is a polynomial algorithm which gives a solution dominating at least $2\sqrt{N} - 1$ vertices. Moreover, there is no solution which dominates more than $2\sqrt{N} - 1$ vertices in an infinite number of instances.

6 Conclusion

In this paper, we have shown that determining if there is a solution for the *IDO* problem is *NP*-complete, even if the graph is a path and the obligations are stable and λ -balanced (with $\lambda \geq 2$), or if the graph has a diameter 3 and the obligations are stable and λ -balanced (with $\lambda \geq 2$). However, determining if there is a solution for the *IDO* problem is clearly polynomial for graphs with diameter 1. The case of diameter 2 is still to be studied. We have also shown that determining if there is a solution for the *IDO* problem is *NP*-complete, even if there are less or more than \sqrt{N} stable obligations balanced. However, determining if there is a solution for the *IDO* problem can be solve in pseudo-polynomial time if the number of obligations is constant. The existence of a fully polynomial time algorithm for a small number of obligations is still to be studied. Finally, we proved that the *IDO* problem stays *NP*-complete when we remove the constraint of dominating each vertex, even if we want to dominate only at least $3\sqrt{N} - 2$ vertices (with N the number of vertices of the graph). However, we proved that there is always a solution which can dominate $2\sqrt{N} - 1$ vertices if obligations are stable. We have also given a fully polynomial time algorithm to get this solution. Hence the order of magnitude is tight. However, a reduction of the gap polynomial and *NP*-complete cases is still open.

References

- [1] A. Akbari et al. *Independent Domination in Subcubic Graphs*. 2020. arXiv: 2001.02946 [cs.DM].
- [2] Claude Berge. “Theory of Graphs and its Applications”. In: *IL, Moscow* (1962), pp. 150–152.
- [3] Miroslav Chlebík and Janka Chlebíková. “Approximation Hardness of Dominating Set Problems”. In: *Algorithms – ESA 2004*. Ed. by Susanne Albers and Tomasz Radzik. Berlin, Heidelberg: Springer Berlin Heidelberg, 2004, pp. 192–203.
- [4] Alexis Cornet and Christian Laforest. “Graph Problems with Obligations”. In: *Combinatorial Optimization and Applications*. Ed. by Donghyun Kim, R. N. Uma, and Alexander Zelikovsky. Vol. (LNCS) 11346. Cham: Springer International Publishing, 2018, pp. 183–197.
- [5] Michael R. Garey and David S. Johnson. *Computers and Intractability: A Guide to the Theory of NP-Completeness*. New York, NY, USA: W. H. Freeman & Co., 1979.
- [6] Teresa W Haynes, Stephen Hedetniemi, and Peter Slater. *Domination in Graphs: Advanced Topics*. CRC press, 1998.
- [7] Teresa W Haynes, Stephen Hedetniemi, and Peter Slater. *Fundamentals of domination in graphs*. Marcel Dekker, 1998.
- [8] Robert W. Irving. “On approximating the minimum independent dominating set”. In: *Information Processing Letters* 37.4 (1991), pp. 197–200.

- [9] Oystein Ore. *Theory of graphs*. Vol. 38. American Mathematical Soc., 1965.
- [10] Johan M.M. [van Rooij] and Hans L. Bodlaender. “Exact algorithms for dominating set”. In: *Discrete Applied Mathematics* 159.17 (2011), pp. 2147–2164.