



HAL
open science

Optimal control

Jean Pierre Corriou

► **To cite this version:**

Jean Pierre Corriou. Optimal control. Sohrab Rohani. Coulson and Richardson's Chemical Engineering: Volume 3B: Process Control, Fourth Edition, 2017, 978-0-08-101095-2. hal-02946760

HAL Id: hal-02946760

<https://hal.science/hal-02946760v1>

Submitted on 23 Sep 2020

HAL is a multi-disciplinary open access archive for the deposit and dissemination of scientific research documents, whether they are published or not. The documents may come from teaching and research institutions in France or abroad, or from public or private research centers.

L'archive ouverte pluridisciplinaire **HAL**, est destinée au dépôt et à la diffusion de documents scientifiques de niveau recherche, publiés ou non, émanant des établissements d'enseignement et de recherche français ou étrangers, des laboratoires publics ou privés.

Chapter 10

Optimal Control

Jean-Pierre Corriou
LRGP-CNRS-ENSIC, Lorraine University
1, rue Grandville BP 20451
54001 Nancy Cedex
France
e-mail: jean-pierre.corriou@univ-lorraine.fr

10.1 Introduction

Frequently, the engineer in charge of a process is faced with optimization problems. In fact, this may cover relatively different ideas, such as parameter identification or process optimization.

It is known that the reactive feed flow rate profile for a fed-batch reactor and the temperature or pressure profile to be followed for a batch reactor, will have an influence on the yield, the selectivity or the product quality. To optimize production, one must then seek a time profile and perform a dynamic optimization with respect to the manipulated variables, while respecting the constraints of the system such as the bounds on temperature and temperature rise rate, the constraints related to the possible runaway of the reactor. Similarly, to optimize the conversion in a tubular reactor, one can seek the optimal temperature profile along the reactor. In the latter case, it is a spatial optimization very close to the dynamic optimization where the time is replaced by the abscissa along the reactor. The profile thus determined is calculated in open loop and will be applied as the set point in closed loop, which may lead to deviations between the effective result and the desired result. The direct closed-loop calculation of the profile in the nonlinear case is not studied here; on the contrary, the linear case is treated in linear quadratic control and Gaussian linear quadratic control.

In a continuous process, problems of dynamic optimization can also be considered with respect to the process changes from the nominal regime. For

example, the quality of the raw petroleum feeding the refineries changes very often. The economic optimization realized off-line imposes set point variations on the distillation columns. An objective can be to find the optimal profile to be followed during the change from one set of set points to another set.

In all cases, a dynamic model sufficiently representative of the behaviour of the process is necessary, nevertheless of a reasonable complexity with respect to the difficulty of the mathematician and numerical task of solving.

Among the criteria to be optimized, can be found the reaction yield or the selectivity, and also the end-time taken to reach a given yield, or any technical-economic criterion which simultaneously takes into account technical objectives, production or investment costs.

Optimal control is the formulation of the dynamic optimization methods in the framework of a control problem.

10.2 Problem Statement

The optimal control problem is first set in continuous time. The studied system is assumed to be nonlinear.

The fixed aim in this problem is the determination of the control $\mathbf{u}(t)$ minimizing a criterion $J(\mathbf{u})$ while verifying initial and final conditions and respecting constraints. The optimal control thus denoted by $\mathbf{u}^*(t)$ makes the state $\mathbf{x}(t)$ follow a trajectory $\mathbf{x}^*(t)$ which must belong to the set of admissible trajectories.

The formulation of the optimal control problem is the following:

Consider a system described in state space by the set of differential equations

$$\dot{\mathbf{x}}(t) = \mathbf{f}(\mathbf{x}(t), \mathbf{u}(t)) \quad ; \quad t_0 \leq t \leq t_f \quad (10.1)$$

with \mathbf{x} being a state vector of dimension n and \mathbf{u} a control vector of dimension m . The system is subjected to initial and final conditions, called terminal (or at the boundaries)

$$\mathbf{k}(\mathbf{x}(t_0), t_0) = 0 \quad ; \quad \mathbf{l}(\mathbf{x}(t_f), t_f) = 0 \quad (10.2)$$

Moreover, the system can be subjected to instantaneous inequality constraints

$$\mathbf{p}(\mathbf{x}(t), \mathbf{u}(t), t) \leq 0 \quad \forall t \quad (10.3)$$

or integral constraints (depending only on t_0 and t_f)

$$\int_{t_0}^{t_f} q(\mathbf{x}(t), \mathbf{u}(t), t) dt \leq 0 \quad (10.4)$$

The question is to find the set of the admissible controls $\mathbf{u}(t)$ which minimize a technical or economic performance criterion $J(\mathbf{u})$

$$J(\mathbf{u}) = G(\mathbf{x}(t_0), t_0, \mathbf{x}(t_f), t_f) + \int_{t_0}^{t_f} F(\mathbf{x}(t), \mathbf{u}(t), t) dt \quad (10.5)$$

G is called the algebraic part of the criterion. F is a functional. Frequently, the initial instant is taken as $t_0 = 0$.

In this very general form, this problem makes use of the equality constraints corresponding to the state differential equations, the terminal equality constraints, possibly instantaneous or integral inequality constraints, and m independent functions, which are the controls $\mathbf{u}(t)$. The term $G(\mathbf{x}(t_0), t_0, \mathbf{x}(t_f), t_f)$ represents a contribution of the terminal conditions to the criterion whereas the integral term of Eq. (10.5) represents a time-accumulation contribution.

Several methods allow us to solve this type of problem: variational methods [Kirk, 1970], Pontryagin maximum principle [Pontryaguine et al., 1974], Bellman dynamic programming [Bellman, 1957]. The books cited here [Borne et al., 1990, Boudarel et al., 1969, Bryson, 1999, Bryson and Ho, 1975, Feldbaum, 1973, Pun, 1972, Ray and Szekely, 1973] propose compared approaches.

10.3 Optimal Control

10.3.1 Variational Methods

The basis of optimal control lies in variational calculus which provides the fundamental principles in a mathematical framework [Corriou, 2004, 2012]. The way to obtain the solution of the optimal control problem will be presented by first studying the variation of the criterion, then by three progressively more complete methods in continuous-time, i.e. Euler conditions, Hamilton-Jacobi theory and Pontryagin maximum principle. Finally, in discrete time, Bellman optimality principle will be presented.

The variables are divided in two types: state variables x_i ($1 \leq i \leq n$) and control variables u_j ($1 \leq j \leq m$), so that the optimal control problem is formulated as:

Given a criterion

$$J(\mathbf{u}) = G(\mathbf{x}(t_0), \mathbf{u}(t_0), \mathbf{x}(t_f), \mathbf{u}(t_f)) + \int_{t_0}^{t_f} F(\mathbf{x}(t), \mathbf{u}(t), t) dt \quad (10.6)$$

determine the optimal control trajectory $\mathbf{u}^*(t)$ that minimizes $J(\mathbf{u})$

$$\mathbf{u}^*(t) = \arg \left\{ \min_{\mathbf{u}} J(\mathbf{u}) \right\} \quad (10.7)$$

the state and control variables being subjected to the constraints

$$\text{Model : } \phi_i = \dot{x}_i - f_i(\mathbf{x}, \mathbf{u}, t) = 0 \quad i = 1, \dots, n \quad (10.8)$$

$$\text{Initial conditions : } k_j(\mathbf{x}(t_0), \mathbf{u}(t_0), t_0) = 0 \quad j = 1, \dots, n_0 \quad (10.9)$$

$$\text{Final conditions : } l_j(\mathbf{x}(t_f), \mathbf{u}(t_f), t_f) = 0 \quad j = n_0 + 1, \dots, n_0 + n_1 \leq 2n + 2 \quad (10.10)$$

In the criterion (10.6), the first term G is called the algebraic part and the second term is called the integral part. F is the functional. Note that the ordinary differential equations (10.8) represent the dynamic model of the process. Initial and final conditions, resp. (10.9) and (10.10) are algebraic equations.

10.3.2 Variation of the Criterion

Three general ideas, but different, will be evoked to describe the criterion variation.

- In the most general case, the criterion variation is equal to

$$\begin{aligned}
\delta J = & \int_{t_0}^{t_f} \left\{ \left[\left(\frac{\partial F}{\partial \mathbf{x}} \right)^T - \boldsymbol{\psi}(t)^T \frac{\partial \mathbf{f}}{\partial \mathbf{x}} \right] \delta \mathbf{x} + \left[\left(\frac{\partial F}{\partial \mathbf{u}} \right)^T - \boldsymbol{\psi}(t)^T \frac{\partial \mathbf{f}}{\partial \mathbf{u}} \right] \delta \mathbf{u} \right\} dt \\
& + F(\mathbf{x}_f, \mathbf{u}_f, t_f) \delta t_f - F(\mathbf{x}_0, \mathbf{u}_0, t_0) \delta t_0 \\
& + \left[\left(\frac{\partial G}{\partial t_0} \right) \delta t_0 + \left(\frac{\partial G}{\partial \mathbf{x}_0} \right) \delta \mathbf{x}_0 + \left(\frac{\partial G}{\partial \mathbf{u}_0} \right) \delta \mathbf{u}_0 \right] \\
& + \left[\left(\frac{\partial G}{\partial t_f} \right) \delta t_f + \left(\frac{\partial G}{\partial \mathbf{x}_f} \right) \delta \mathbf{x}_f + \left(\frac{\partial G}{\partial \mathbf{u}_f} \right) \delta \mathbf{u}_f \right] \\
& + \boldsymbol{\psi}(t_f)^T \delta \mathbf{x}_f - \boldsymbol{\psi}(t_0)^T \delta \mathbf{x}_0 - \int_{t_0}^{t_f} \dot{\boldsymbol{\psi}}(t)^T \delta \mathbf{x} dt
\end{aligned} \tag{10.11}$$

- If, according to Hamilton-Jacobi theory (Sect. 10.3.5), we furthermore introduce the Hamiltonian H equal to

$$H(\mathbf{x}, \mathbf{u}, \boldsymbol{\psi}, t) = -F(\mathbf{x}, \mathbf{u}, t) + \boldsymbol{\psi}(t)^T \mathbf{f}(\mathbf{x}, \mathbf{u}, t) \tag{10.12}$$

the criterion (10.6) becomes

$$J(\mathbf{u}) = G(\mathbf{x}(t_0), \mathbf{u}(t_0), \mathbf{x}(t_f), \mathbf{u}(t_f)) + \int_{t_0}^{t_f} [\boldsymbol{\psi}(t)^T \mathbf{f}(\mathbf{x}, \mathbf{u}, t) - H(\mathbf{x}, \mathbf{u}, \boldsymbol{\psi}, t)] dt \tag{10.13}$$

or

$$J(\mathbf{u}) = G(\mathbf{x}(t_0), \mathbf{u}(t_0), \mathbf{x}(t_f), \mathbf{u}(t_f)) + \int_{t_0}^{t_f} [\boldsymbol{\psi}(t)^T \dot{\mathbf{x}}(t) - H(\mathbf{x}, \mathbf{u}, \boldsymbol{\psi}, t)] dt \tag{10.14}$$

Using the integration by parts, the variation of the criterion becomes

$$\begin{aligned}
\delta J = & \int_{t_0}^{t_f} \left\{ - \left[\left(\frac{\partial H}{\partial \mathbf{x}} \right)^T + \dot{\boldsymbol{\psi}}(t)^T \right] \delta \mathbf{x} - \left[\left(\frac{\partial H}{\partial \mathbf{u}} \right)^T \right] \delta \mathbf{u} \right\} dt \\
& + \left[\left(\frac{\partial G}{\partial t_0} \right) + H(\mathbf{x}_0, \mathbf{u}_0, \boldsymbol{\psi}_0, t_0) \right] \delta t_0 + \left[\left(\frac{\partial G}{\partial \mathbf{x}_0} \right) - \boldsymbol{\psi}(t_0)^T \right] \delta \mathbf{x}_0 + \left(\frac{\partial G}{\partial \mathbf{u}_0} \right) \delta \mathbf{u}_0 \\
& + \left[\left(\frac{\partial G}{\partial t_f} \right) - H(\mathbf{x}_f, \mathbf{u}_f, \boldsymbol{\psi}_f, t_f) \right] \delta t_f + \left[\left(\frac{\partial G}{\partial \mathbf{x}_f} \right) + \boldsymbol{\psi}(t_f)^T \right] \delta \mathbf{x}_f + \left(\frac{\partial G}{\partial \mathbf{u}_f} \right) \delta \mathbf{u}_f
\end{aligned} \tag{10.15}$$

This equation, giving the variation of the criterion, is necessary for understanding the origin of Hamilton-Jacobi equations (Sect. 10.3.5).

10.3.3 Euler Conditions

According to the performance index, the augmented function F^a is defined

$$F^a(\mathbf{x}, \dot{\mathbf{x}}, \mathbf{u}, t) = F(\mathbf{x}, \mathbf{u}, t) + \sum_{i=1}^n \lambda_i \phi_i \quad (10.16)$$

Notice that the function G does not intervene in this augmented function, as G depends only on the terminal conditions. G would only intervene in F^a if the terminal conditions were varying.

The variables are the control vector $u(t)$, the state vector $x(t)$ and the Euler-Lagrange multipliers λ . Euler conditions give

$$\begin{aligned} \frac{\partial F^a}{\partial u_j} - \frac{d}{dt} \frac{\partial F^a}{\partial \dot{u}_j} &= 0 & j = 1, \dots, m \\ \frac{\partial F^a}{\partial x_i} - \frac{d}{dt} \frac{\partial F^a}{\partial \dot{x}_i} &= 0 & i = 1, \dots, n \\ \frac{\partial F^a}{\partial \lambda_i} - \frac{d}{dt} \frac{\partial F^a}{\partial \dot{\lambda}_i} &= 0 & i = 1, \dots, n \end{aligned} \quad (10.17)$$

The third group of this system of equations corresponds to the constraints $\phi_i = 0$ that define the dynamic model, thus corresponds to a system of differential equations with respect to the state derivatives \dot{x} . The first group is a system of algebraic equations. The second group is a system of differential equations with respect to $\dot{\lambda}$.

If inequality constraints of the type (10.3) or (10.4) are present, the Valentine's method should be used to modify F^a consequently.

On the other hand, the terminal conditions (10.9) and (10.10), which are transversality and discontinuity conditions, as well as the conditions relative to the second variations will have to be verified.

The transversality equations (refer to eq. (10.15)) are:

At initial time t_0

$$\begin{aligned} \left[-\frac{\partial G}{\partial t_0} + (F^a - \boldsymbol{\lambda}^T \dot{\mathbf{x}})_0 \right] \delta t_0 + \left[-\frac{\partial G}{\partial \mathbf{x}_0} + \boldsymbol{\lambda}(t_0) \right]^T \delta \mathbf{x}_0 &= 0 \\ \text{with: } \left(\frac{\partial \mathbf{k}}{\partial t} \right)_0 \delta t_0 + \left(\frac{\partial \mathbf{k}}{\partial \mathbf{x}} \right)_0 \delta \mathbf{x}_0 &= 0 \end{aligned} \quad (10.18)$$

At final time t_f

$$\begin{aligned} \left[\frac{\partial G}{\partial t_f} + (F^a - \boldsymbol{\lambda}^T \dot{\mathbf{x}})_f \right] \delta t_f + \left[\frac{\partial G}{\partial \mathbf{x}_f} + \boldsymbol{\lambda}(t_f) \right]^T \delta \mathbf{x}_f &= 0 \\ \text{with: } \left(\frac{\partial \mathbf{l}}{\partial t} \right)_f \delta t_f + \left(\frac{\partial \mathbf{l}}{\partial \mathbf{x}} \right)_f \delta \mathbf{x}_f &= 0 \end{aligned} \quad (10.19)$$

For a fixed final time, which is a frequently met condition, from Eq. (10.19), the following condition results

$$\boldsymbol{\lambda}(t_f) = -\frac{\partial G}{\partial \mathbf{x}_f} \quad (10.20)$$

It must be underlined that, as such, Euler conditions provide only first-order conditions, which is not sufficient for an optimality problem. To determine the nature of the extremum, second-order conditions must be studied.

10.3.4 Weierstrass Condition and Hamiltonian Maximization

To complete the study of the extremum provided Euler conditions, it is necessary to make use of more advanced concepts and the use of Hamilton that will be presented later in section 10.3.5.

Considering the augmented function

$$F^a(\mathbf{x}, \dot{\mathbf{x}}, \mathbf{u}, t) = F(\mathbf{x}, \mathbf{u}, t) + \boldsymbol{\lambda}^T [\dot{\mathbf{x}} - \mathbf{f}(\mathbf{x}, \mathbf{u}, t)] \quad (10.21)$$

the Weierstrass condition relative to second variations is applied to in the neighbourhood of the optimum noted \mathbf{x}^* obtained for the optimal control \mathbf{u}^* , thus

$$F^a(\mathbf{x}^*, \dot{\mathbf{x}}, \mathbf{u}, t) - F^a(\mathbf{x}^*, \dot{\mathbf{x}}^*, \mathbf{u}^*, t) - (\dot{\mathbf{x}} - \dot{\mathbf{x}}^*)^T \left(\frac{\partial F^a}{\partial \dot{\mathbf{x}}} \right)_* \geq 0 \quad (10.22)$$

By clarifying these terms and using the constraints

$$\begin{aligned} \dot{\mathbf{x}} &= \mathbf{f}(\mathbf{x}^*, \mathbf{u}, t) \\ \dot{\mathbf{x}}^* &= \mathbf{f}(\mathbf{x}^*, \mathbf{u}^*, t) \end{aligned} \quad (10.23)$$

the Weierstrass condition is simplified as

$$\begin{aligned} F(\mathbf{x}^*, \mathbf{u}, t) - F(\mathbf{x}^*, \mathbf{u}^*, t) - \boldsymbol{\lambda}^T (\mathbf{f}(\mathbf{x}^*, \mathbf{u}, t) - \mathbf{f}(\mathbf{x}^*, \mathbf{u}^*, t)) &\geq 0 \iff \\ \left[\boldsymbol{\lambda}^T \mathbf{f}(\mathbf{x}^*, \mathbf{u}^*, t) - F(\mathbf{x}^*, \mathbf{u}^*, t) \right] - \left[\boldsymbol{\lambda}^T \mathbf{f}(\mathbf{x}^*, \mathbf{u}, t) - F(\mathbf{x}^*, \mathbf{u}, t) \right] &\geq 0 \end{aligned} \quad (10.24)$$

in which the expression of the Hamiltonian (setting $\boldsymbol{\lambda} = \boldsymbol{\psi}$) can be recognized as

$$H(\mathbf{x}^*, \mathbf{u}, \boldsymbol{\lambda}, t) = -F(\mathbf{x}^*, \mathbf{u}, t) + \boldsymbol{\lambda}^T \mathbf{f}(\mathbf{x}^*, \mathbf{u}, t) \quad (10.25)$$

It results the fundamental conclusion that the optimal control maximizes the Hamiltonian while respecting the constraints

$$H(\mathbf{x}^*, \mathbf{u}^*, \boldsymbol{\lambda}, t) \geq H(\mathbf{x}^*, \mathbf{u}, \boldsymbol{\lambda}, t) \quad (10.26)$$

which will be generalized as Pontryagin's maximum principle.

Legendre-Clebsch condition for small variations would have allowed us to obtain the stationarity condition at the optimal trajectory, in the absence of constraints, as

$$\left(\frac{\partial H}{\partial u} \right)_* = 0 \quad (10.27)$$

and

$$\left(\frac{\partial^2 H}{\partial u^2} \right)_* \leq 0 \quad (10.28)$$

10.3.5 Hamilton-Jacobi Conditions and Equation

The Hamiltonian is deduced from the criterion (10.6) and from constraints (10.8); it is equal to

$$H(\mathbf{x}(t), \mathbf{u}(t), \boldsymbol{\psi}(t), t) = -F(\mathbf{x}(t), \mathbf{u}(t), t) + \boldsymbol{\psi}^T(t) \mathbf{f}(\mathbf{x}(t), \mathbf{u}(t), t) \quad (10.29)$$

Other authors use the definition of the Hamiltonian with an opposite sign before the functional, i.e.

$$H(\mathbf{x}(t), \mathbf{u}(t), \boldsymbol{\psi}(t), t) = F(\mathbf{x}(t), \mathbf{u}(t), t) + \boldsymbol{\psi}^T(t) \mathbf{f}(\mathbf{x}(t), \mathbf{u}(t), t)$$

which changes nothing, as long as we remain at the level of first-order conditions. However, the sign changes in condition (10.20).

The variation of the criterion has been expressed with respect to the Hamiltonian through Eq. (10.15). The canonical system of Hamilton conditions results as

$$\begin{aligned} \dot{\mathbf{x}} &= H_{\boldsymbol{\psi}} \\ \dot{\boldsymbol{\psi}} &= -H_{\mathbf{x}} \end{aligned} \quad (10.30)$$

which are equivalent to Euler conditions, to which the following equation must be added

$$H_t = -F_t \quad (10.31)$$

The second equation of (10.30) is, in fact, a system of equations called the costate equations, and $\boldsymbol{\psi}$ is called the costate or the vector of adjoint variables.

The derivative of the Hamiltonian is equal to

$$\frac{dH}{dt} = H_{\mathbf{x}}^T \dot{\mathbf{x}} + H_{\mathbf{u}}^T \dot{\mathbf{u}} + H_{\boldsymbol{\psi}}^T \dot{\boldsymbol{\psi}} + H_t = H_{\mathbf{u}}^T \dot{\mathbf{u}} + H_t \quad (10.32)$$

If $u(t)$ is an optimal control, one deduces

$$\dot{H} = H_t \quad (10.33)$$

Generally, the concerned physical system is time-invariant so that time does not intervene explicitly in \mathbf{f} and also in the functional F , so that Eq. (10.33) becomes

$$\dot{H} = 0 \quad (10.34)$$

In this case, the Hamiltonian is constant along the optimal trajectory.

The transversality conditions (refer to eq. (10.15)) are:

At initial time t_0

$$\begin{aligned} &\left[\frac{\partial G}{\partial t_0} + H(t_0) \right] \delta t_0 + \left[\frac{\partial G}{\partial \mathbf{x}_0} - \boldsymbol{\psi}(t_0) \right]^T \delta \mathbf{x}_0 + \frac{\partial G}{\partial u_0} \delta u_0 = 0 \\ \text{with: } &\left(\frac{\partial \mathbf{k}}{\partial t} \right)_0 \delta t_0 + \left(\frac{\partial \mathbf{k}}{\partial \mathbf{x}} \right)_0 \delta \mathbf{x}_0 = 0 \end{aligned} \quad (10.35)$$

At final time t_f

$$\begin{aligned} \left[\frac{\partial G}{\partial t_f} - H(t_f) \right] \delta t_f + \left[\frac{\partial G}{\partial \mathbf{x}_f} + \boldsymbol{\psi}(t_f) \right]^T \delta \mathbf{x}_f + \frac{\partial G}{\partial u_f} \delta u_f &= 0 \\ \text{with: } \left(\frac{\partial \mathcal{L}}{\partial t} \right)_f \delta t_f + \left(\frac{\partial \mathcal{L}}{\partial \mathbf{x}} \right)_f \delta \mathbf{x}_f &= 0 \end{aligned} \quad (10.36)$$

It is possible to calculate the variation $\delta \mathcal{J}$ associated with the variation δt and with the trajectory change of $\delta \mathbf{x}$, the extremity \mathbf{x}_f being fixed, for the time-dependent criterion \mathcal{J} defined by

$$\mathcal{J}(\mathbf{x}^*, t) = G(\mathbf{x}^*(t_f), t_f) + \int_t^{t_f} F(\mathbf{x}^*, \mathbf{u}^*, \tau) d\tau \quad (10.37)$$

Note that

$$\mathcal{J}(\mathbf{x}^*, t_0) = J(\mathbf{u}^*) \quad (10.38)$$

The variation of the criterion can be expressed with respect to the Hamiltonian

$$\begin{aligned} \delta \mathcal{J}(\mathbf{x}^*, t) &= \mathcal{J}(\mathbf{x}^* + \delta \mathbf{x}(t), t + \delta t) - \mathcal{J}(\mathbf{x}^*, t) \\ &= H(\mathbf{x}^*, \mathbf{u}^*, \boldsymbol{\psi}, t) \delta t - \boldsymbol{\psi}^T(t) \delta \mathbf{x}(t) \end{aligned} \quad (10.39)$$

The optimal control corresponds to a maximum of the Hamiltonian. Frequently, the control vector is bounded in a domain U defined by \mathbf{u}_{\min} and \mathbf{u}_{\max} . In this case, the condition that the Hamiltonian is maximum can be expressed in two different ways:

- When a constraint u_i is reached, the function H defined by Eq. (10.29) must be a maximum.
- When the control belongs strictly to the inner feasible domain U defined by \mathbf{u}_{\min} and \mathbf{u}_{\max} , not reaching the bounds, the derivative of function H defined by Eq. (10.29) with respect to \mathbf{u} is zero

$$\frac{\partial H}{\partial \mathbf{u}} = 0 \quad (10.40)$$

This equation provides an implicit equation that allows us to express the optimal control with respect only to variables $\mathbf{x}, \boldsymbol{\psi}, t$: $\mathbf{u}^* = \mathbf{u}^*(\mathbf{x}, \boldsymbol{\psi}, t)$, hence the new expression of the criterion

$$\begin{aligned} \delta \mathcal{J}(\mathbf{x}^*, t) &= H(\mathbf{x}^*, \mathbf{u}^*(\mathbf{x}, \boldsymbol{\psi}, t), \boldsymbol{\psi}, t) \delta t - \boldsymbol{\psi}^T(t) \delta \mathbf{x}(t) \\ &= \mathcal{J}_t \delta t + \mathcal{J}_x^T \delta \mathbf{x} \end{aligned} \quad (10.41)$$

thus by identification

$$\begin{aligned} \mathcal{J}_t &= H(\mathbf{x}^*, \mathbf{u}^*(\mathbf{x}, \boldsymbol{\psi}, t), \boldsymbol{\psi}, t) \\ \mathcal{J}_x &= -\boldsymbol{\psi}(t) \end{aligned} \quad (10.42)$$

This equation shows that the optimal value of the Hamiltonian is equal to the derivative of criterion (10.37) with respect to time. The Hamilton-Jacobi equation results

$$\mathcal{J}_t - H(\mathbf{x}^*, \mathbf{u}^*(\mathbf{x}, -\mathcal{J}\mathbf{x}, t), -\mathcal{J}\mathbf{x}, t) = 0 \quad (10.43)$$

with boundary condition

$$\mathcal{J}(\mathbf{x}_f^*, t_f) = G(\mathbf{x}^*(t_f), t_f) \quad (10.44)$$

The Hamilton-Jacobi equation is a first-order partial derivative equation with respect to the sought function \mathcal{J} . Its solving is, in general, analytically impossible for a nonlinear system. In the case of a linear system such as Eq.(10.89), its solving is possible and leads to a Riccati differential equation (10.106). Thus, it is possible to calculate the optimal control law by state feedback. Recall that the Hamilton-Jacobi Eq.(10.43) in discrete form corresponds to the Bellman optimality principle in dynamic programming (Sect. 10.4).

Case with constraints on control and state variables

Assume that general constraints of the form

$$g(x(t), u(t), t) = 0 \quad (10.45)$$

are to be respected in the considered problem. In that case, the augmented Hamiltonian is to be considered

$$H(x(t), u(t), \psi(t), t) = -F(x(t), u(t), t) + \psi^T(t)f(x(t), u(t), t) + \mu^T g(x(t), u(t), t) \quad (10.46)$$

where μ is a vector of additional Lagrange multipliers. The Hamiltonian derivative yields

$$\frac{\partial H}{\partial u} = -\frac{\partial F}{\partial u} + \psi^T(t)\frac{\partial f}{\partial u} + \mu^T \frac{\partial g}{\partial u} = 0 \quad (10.47)$$

together with equation (10.30) as

$$\dot{\psi} = -H\mathbf{x} = F\mathbf{x} - \psi^T(t) f\mathbf{x} - \mu^T g\mathbf{x} \quad (10.48)$$

Particular cases of (10.45) are those where the constraints g depend only on the states or where a constraint on the state is valid only for a specific time t_1 , such as

$$g(x(t_1), t_1) = 0 \quad (10.49)$$

called interior-point constraints [Bryson and Ho, 1975]. In that latter case, the state is continuous, but the Hamiltonian H and the adjoint variables ψ are no more continuous. Noting t_1^- and t_1^+ the times just before and after t_1 , given the criterion J , they must verify the following relations

$$\psi^T(t_1^+) = \frac{\partial J}{\partial x(t_1)} \quad ; \quad H(t_1^+) = -\frac{\partial J}{\partial t_1} \quad (10.50)$$

and

$$\psi^T(t_1^+) = \psi^T(t_1^-) - \nu^T \frac{\partial g}{\partial \mathbf{x}(t_1)} \quad ; \quad H(t_1^+) = H(t_1^-) + \nu^T \frac{\partial g}{\partial t_1} \quad (10.51)$$

where ν are Lagrange multipliers such that constraints (10.49) are satisfied.

Case with terminal constraints

A case frequently encountered in dynamic optimization is the one where terminal constraints are imposed

$$l_j(\mathbf{x}(t_f), \mathbf{u}(t_f), t_f) = 0 \quad (10.52)$$

The transversality equation (10.36) becomes

$$\left[\frac{\partial G}{\partial t_f} - H(t_f) + \frac{\partial \mathbf{l}^T}{\partial t_f} \boldsymbol{\nu} \right] \delta t_f + \left[\frac{\partial G}{\partial \mathbf{x}_f} + \boldsymbol{\psi}(t_f) + \frac{\partial \mathbf{l}^T}{\partial \mathbf{x}_f} \boldsymbol{\nu} \right]^T \delta \mathbf{x}_f + \frac{\partial G}{\partial u_f} \delta u_f = 0 \quad (10.53)$$

where $\boldsymbol{\nu}$ is a vector of Lagrange parameters. If the final time is fixed, the first term of equation (10.53) disappears. If the component $\mathbf{x}_i(t_f)$ is fixed at final time, that component disappears in equation (10.53).

10.3.6 Maximum Principle

In many articles, authors refer to the Minimum Principle, which simply results from the definition of the Hamiltonian H with an opposite sign of the functional. Comparing to definition (10.29), they define their Hamiltonian as

$$H(\mathbf{x}(t), \mathbf{u}(t), \boldsymbol{\psi}(t), t) = F(\mathbf{x}(t), \mathbf{u}(t), t) + \boldsymbol{\psi}^T(t) \mathbf{f}(\mathbf{x}(t), \mathbf{u}(t), t) \quad (10.54)$$

With that definition, the optimal control u^* minimizes the Hamiltonian. Furthermore, the so-called Minimum Principle presented in many articles is no more than Hamilton-Jacobi exposed in the previous section.

In the present section, the presentation follows the original publication by [Pontryaguine et al., 1974] and completes Hamilton-Jacobi theory. Now, examine briefly the Maximum Principle [Pontryaguine et al., 1974] about process optimal control. Pontryagin emphasizes several points:

- An important difference with respect to variational methods is that it is not necessary to consider two close controls in the admissible control domain.
- The control variables u_i are physical, thus they are constrained, e.g. $|u_1| \leq u_{\max}$, and they belong to a domain U . The admissible controls are piecewise continuous, that is, they are continuous nearly everywhere, except at some instants where they can undergo first-order discontinuities (jump from one value to another).
- Very frequently, the optimal control is composed by piecewise continuous functions: the control jumps from one summit of the polyhedron defined by U to another. These cases of control occupying only extreme positions cannot be solved by classical methods.

The process is described by a system of differential equations

$$\dot{x}^i(t) = f^i(\mathbf{x}(t), \mathbf{u}(t)) \quad i = 1, \dots, n \quad (10.55)$$

An admissible control \mathbf{u} is sought that transfers the system from point \mathbf{x}_0 in the phase space to point \mathbf{x}_f and minimizes the criterion

$$J = G(\mathbf{x}_0, t_0, \mathbf{x}_f, t_f) + \int_{t_0}^{t_f} F(\mathbf{x}(t), \mathbf{u}(t)) dt \quad (10.56)$$

To the n coordinates x^i in the phase space, we add the coordinate x^0 defined by

$$x^0 = G(\mathbf{x}_0, t_0, \mathbf{x}(t), t) + \int_{t_0}^t F(\mathbf{x}(\tau), \mathbf{u}(\tau)) d\tau \quad (10.57)$$

so that if $\mathbf{x} = \mathbf{x}_f$ then $x^0(t_f) = J$. This notation is that of Pontryaguine et al. [1974]. The superscript corresponds to the rank i of the coordinate while the subscripts (0 and 1) or (0 and f), according to the authors, are reserved for the terminal conditions. The derivative of x^0 is equal to

$$\frac{dx^0}{dt} = G_{\mathbf{x}}^T \mathbf{f} + G_t + F(\mathbf{x}(t), \mathbf{u}(t)) \quad (10.58)$$

If time intervenes explicitly in the terminal conditions (10.2), or if it is not first fixed, we add the coordinate x^{n+1} to the state [Boudarel et al., 1969], such that

$$\begin{aligned} x^{n+1} &= t \\ \dot{x}^{n+1} &= 1 \end{aligned} \quad (10.59)$$

The complete system of differential equations would then have dimension $n+2$. In the following, in order not to make the notations cumbersome, we will only consider stationary problems of dimension $n+1$ in the form

$$\dot{x}^i = f^i(\mathbf{x}(t), \mathbf{u}(t)) \quad i = 0, \dots, n \quad (10.60)$$

by deducing f^0 from Eq. (10.57) by derivation (extended notation \mathbf{f}).

In the phase space of dimension $n+1$, we define the initial point \mathbf{x}_0 and a straight line π parallel to the axis x^0 (i.e. the criterion), passing through the final point \mathbf{x}_f . The optimal control is, among the admissible controls such that the solution $\mathbf{x}(t)$, having as the initial condition \mathbf{x}_0 , intersects the line π , the one which minimizes the coordinate x^0 at the intersection point with π .

The costate variables ψ are introduced such that

$$\dot{\psi} = -\mathbf{f}_{\mathbf{x}}^T \psi \iff \dot{\psi}_i = -\sum_{j=0}^n \frac{\partial f^j(\mathbf{x}(t), \mathbf{u}(t))}{\partial x^i} \psi_j \quad i = 0, \dots, n \quad (10.61)$$

This system admits a unique solution ψ composed of piecewise continuous functions, corresponding to the control \mathbf{u} and presenting the same discontinuity points.

In this setting, the Hamiltonian is equal to the scalar product of functions ψ and f

$$H(\boldsymbol{\psi}, \mathbf{x}, \mathbf{u}) = \boldsymbol{\psi}^T \mathbf{f} = \sum_{i=0}^n \psi_i f^i \quad i = 0, \dots, n \quad (10.62)$$

The systems can be written again in the Hamilton canonical form

$$\begin{aligned} \frac{dx^i}{dt} &= \frac{\partial H}{\partial \psi_i} & i = 0, \dots, n \\ \frac{d\psi_i}{dt} &= -\frac{\partial H}{\partial x^i} & i = 0, \dots, n \end{aligned} \quad (10.63)$$

When the solutions \mathbf{x} and $\boldsymbol{\psi}$ are fixed, the Hamiltonian depends only on the admissible control \mathbf{u} , hence the notation

$$\mathcal{M}(\boldsymbol{\psi}, \mathbf{x}) = \sup_{\mathbf{u} \in U} H(\boldsymbol{\psi}, \mathbf{x}, \mathbf{u}) \quad (10.64)$$

in order to mean that \mathcal{M} is the maximum of H at fixed \mathbf{x} and $\boldsymbol{\psi}$, or further

$$H(\boldsymbol{\psi}^*, \mathbf{x}^*, \mathbf{u}^*) \geq H(\boldsymbol{\psi}^*, \mathbf{x}^*, \mathbf{u}^* + \delta \mathbf{u}) \quad \forall \delta \mathbf{u} \quad (10.65)$$

We consider the admissible controls, defined on $[t_0, t_f]$, to be responding to the previous definition: the trajectory $\mathbf{x}(t)$ issued from \mathbf{x}_0 at t_0 intersects the straight line π at t_f . According to Pontryaguine et al. [1974], the first theorem of the Maximum Principle is expressed as:

So that the control $\mathbf{u}(t)$ and the trajectory $\mathbf{x}(t)$ is optimal, it is necessary that the continuous and nonzero vector, $\boldsymbol{\psi}(t) = [\psi_0(t), \psi_1(t), \dots, \psi_n(t)]$ satisfying Hamilton canonical system (10.63), is such that:

1. The Hamiltonian $H[\boldsymbol{\psi}(t), \mathbf{x}(t), \mathbf{u}(t)]$ reaches its maximum at point $\mathbf{u} = \mathbf{u}(t)$ $\forall t \in [t_0, t_f]$, thus

$$H[\boldsymbol{\psi}(t), \mathbf{x}(t), \mathbf{u}(t)] = \mathcal{M}[\boldsymbol{\psi}(t), \mathbf{x}(t)] \quad (10.66)$$

2. At the end-time t_f , the relations

$$\psi_0(t_f) \leq 0; \quad \mathcal{M}[\boldsymbol{\psi}(t_f), \mathbf{x}(t_f)] = 0 \quad (10.67)$$

are satisfied.

With Eq. (10.63) and condition (10.66) being verified, the time functions $\psi_0(t)$ and $\mathcal{M}[\boldsymbol{\psi}(t), \mathbf{x}(t)]$ are constant. In this case, the relation (10.67) is verified at any instant t included between t_0 and t_f .

10.3.7 Singular Arcs

In optimal control problems, it often occurs for some time intervals that the Maximum Principle does not give an explicit relation between the control and the state and costate variable: this is a singular optimal control problem which yields singular arcs.

Following Lamnabhi-Lagarrigue [1987], an extremal control has a singular arc $[a, b]$ in $[t_0, t_f]$ if and only if $H_u(\boldsymbol{\psi}^*, \mathbf{x}^*, \mathbf{u}^*) = 0$ and $H_{uu}(\boldsymbol{\psi}^*, \mathbf{x}^*, \mathbf{u}^*) = 0$, for all $t \in [a, b]$ and whatever $\boldsymbol{\psi}^*$ satisfies the Maximum Principle.

On the arcs corresponding to control constraints, it gives: $H_u \neq 0$. Thus, a transversality condition must be verified at the junctions between the arcs. [Stengel, 1994] notes that, if a smooth transition of u is possible for some problems, in some cases, it is necessary to perform a Dirac impulse on the control to link the arcs.

Among problem of singular arcs, a frequently encountered case is the one where the Hamiltonian is linear with respect to the control \mathbf{u}

$$H(\mathbf{x}(t), \boldsymbol{\psi}(t), \mathbf{u}(t)) = \alpha(\mathbf{x}(t), \boldsymbol{\psi}(t), t) \mathbf{u}(t) \quad (10.68)$$

In that case, the condition

$$\frac{\partial H}{\partial \mathbf{u}} = 0 \quad (10.69)$$

depends on the sign of α and does not allow us to determine the control with respect to the state and the adjoint vector. To maximize $H(\mathbf{u})$, it results

$$\mathbf{u}(t) = \begin{cases} u_{min} & \text{if: } \alpha < 0 \\ \text{non defined} & \text{if: } \alpha = 0 \\ u_{max} & \text{if: } \alpha > 0 \end{cases} \quad (10.70)$$

The case where $\alpha = 0$ on a given time interval $[t_1, t_2]$ corresponds to a singular arc. It must then be imposed that the time derivatives of $\partial H / \partial u$ be zero along the singular arc. For a unique control u , the generalized Legendre-Clebsch conditions, also called Kelley conditions, which must be verified are

$$(-1)^i \frac{\partial}{\partial u} \left(\frac{d^{2i}}{dt^{2i}} \frac{\partial H}{\partial u} \right) \geq 0 \quad , \quad i = 0, 1, \dots \quad (10.71)$$

so that the singular arc be optimal.

10.3.8 Numerical Issues

In general, the dynamic optimization problem results in a set of two systems of first-order ordinary differential equations

$$\begin{aligned} \dot{\mathbf{x}} &= \dot{\mathbf{x}}(\mathbf{x}, \boldsymbol{\psi}, t) & \text{with: } \mathbf{x}(t_0) &= \mathbf{x}_0 \\ \dot{\boldsymbol{\psi}} &= \dot{\boldsymbol{\psi}}(\mathbf{x}, \boldsymbol{\psi}, t) & \text{with: } \boldsymbol{\psi}(t_f) &= \boldsymbol{\psi}_f \end{aligned} \quad (10.72)$$

where t_0 and t_f are initial and final time respectively. Thus, it is a two-point boundary-value problem. A criterion J is to be minimized with respect to a control vector. In general, in particular for nonlinear problems, there is no analytical solution.

The following general strategy is used to solve the two-point boundary-value problem (10.72): an initial vector $\mathbf{x}(t)$ or $\boldsymbol{\psi}(t)$ or $\boldsymbol{\psi}(t_0)$ or $\mathbf{u}(t)$ is chosen, then by an iterative procedure, the vectors are updated until all equations are respected, including in particular the initial and final conditions.

Different numerical techniques can be used to find the optimal control such as boundary condition iteration, multiple shooting, quasi-linearization, invariant embedding, control vector iteration, control vector parameterization [Goh

and Teo, 1988, Teo et al., 1991], collocation on finite elements or control and state parameterization [Biegler, 1984], iterative dynamic programming [Banga and Carrasco, 1998, Bojkov and Luus, 1996, Carrasco and Banga, 1997, Luus, 1996, Luus and Hennessy, 1999, Mekarapiruk and Luus, 1997]. For more details, refer to [Bryson, 1999, Corriou, 2004, 2012].

10.4 Dynamic Programming

In Euler, Hamilton-Jacobi and Pontryagin approaches, the system is defined in continuous time. In the dynamic programming approach by Bellman, the system is defined in discrete time.

10.4.1 Classical Dynamic Programming

Dynamic programming [Bellman, 1957, Bellman and Dreyfus, 1962] has found many applications in chemical engineering [Aris, 1961, Roberts, 1964], in particular for economic optimization problems in refineries, and was frequently developed in the 1960s. Among typical examples, are the optimization of discontinuous reactors or reactors in series, catalyst replacement or regeneration, the optimization of the counter-current extraction process [Aris et al., 1960], the optimal temperature profile of a tubular chemical reactor [Aris, 1960], the optimization of a cracking reaction [Roberts and Laspe, 1961].

Optimality Principle [Bellman, 1957]:

A policy is optimal if and only if, whatever the initial state and the initial decision, the decisions remaining to be taken constitute an optimal policy with respect to the state resulting from the first decision.

Because of the principle of continuity, the optimal final value of the criterion is entirely determined by the initial condition and the number of stages. In fact, it is possible to start from any stage, even from the last one. For this reason, Kaufmann and Cruon [1965] express the optimality principle in the following manner:

A policy is optimal if, at a given time, whatever the previous decisions, the decisions remaining to be taken constitute an optimal policy with respect to the result of the previous decisions,

or further,

Any sub-policy (from \mathbf{x}_i to \mathbf{x}_j) extracted from an optimal policy (from \mathbf{x}_0 to \mathbf{x}_N) is itself optimal from \mathbf{x}_i to \mathbf{x}_j .

At first, dynamic programming is discussed in the absence of constraints, which could be terminal constraints, constraints at any time (amplitude constraints) on the state \mathbf{x} or on the control u , or inequality constraints. Moreover, we assume the absence of discontinuities.

In fact, as this is a numerical and not analytical solution, these particular cases previously mentioned would pose no problem and could be automatically considered.

In continuous form, the problem is the following:

Consider the state equation

$$\dot{\mathbf{x}} = f(\mathbf{x}, u) \quad \text{with: } \mathbf{x}(0) = \mathbf{x}_0 \quad (10.73)$$

and the performance index to be minimized

$$J(u) = \int_0^{t_f} r(\mathbf{x}, u) dt \quad (10.74)$$

where r represents an income or revenue.

In discrete form, the problem becomes:

Consider the state equation

$$\mathbf{x}_{n+1} = \mathbf{x}_n + f(\mathbf{x}_n, u_n) \Delta t \quad (10.75)$$

with $\Delta t = t_{n+1} - t_n$. The control u_n brings the system from the state \mathbf{x}_n to the state \mathbf{x}_{n+1} and results in an elementary income $r(\mathbf{x}_n, u_n)$ (integrating, in fact, the control period Δt , which will be omitted in the following).

According to the performance index in the integral form, define the performance index or total income at instant N (depending on the initial state \mathbf{x}_0 and the policy \mathcal{U}_0^{N-1} followed from 0 to $N-1$, bringing from the state \mathbf{x}_0 to the state \mathbf{x}_N) as the sum of the elementary incomes $r(\mathbf{x}_i, u_i)$

$$J_0 = \sum_{i=0}^{N-1} r(\mathbf{x}_i, u_i) \quad (10.76)$$

The values of the initial and final states are known

$$\mathbf{x}(t_0) = \mathbf{x}_0 ; \quad \mathbf{x}(t_N) = \mathbf{x}_N \quad (10.77)$$

If the initial instant is n , note the performance index J_n .

The problem is to find the optimal policy $\mathcal{U}_0^{*,N-1}$ constituted by the succession of controls u_i^* ($i = 0, \dots, N-1$) minimizing the performance index J_0 . The optimal performance index $J^*(\mathbf{x}_0, 0)$ is defined as

$$J^*(\mathbf{x}_0, 0) = \min_{u_i} J_0 = \min_{u_i} \sum_{i=0}^{N-1} r(\mathbf{x}_i, u_i) \quad (10.78)$$

This performance index bears on the totality of the N stages and depends on the starting point \mathbf{x}_0 . In fact, the optimality principle can be applied from any instant n , to which corresponds the optimal performance index $J^*(\mathbf{x}_n, n)$

From the optimality principle, the following recurrent algorithm of search of the optimal policy is derived

$$J^*(\mathbf{x}_n, n) = \min_{u_n} [r(\mathbf{x}_n, u_n) + J^*(\mathbf{x}_n + f(\mathbf{x}_n, u_n), n + 1)] \quad (10.79)$$

which allows us to calculate the series $J^*(\mathbf{x}_n, n), J^*(\mathbf{x}_{n-1}, n-1), \dots, J^*(\mathbf{x}_0, 0)$ from the final state \mathbf{x}_N .

If the final state is free, choose $J^*(\mathbf{x}_N, N) = 0$. In the case where it is constrained, the last input u_{N-1}^* is calculated so as to satisfy the constraint.

The algorithm (10.79) could be written as

$$\begin{aligned} J^*(\mathbf{x}_n, n) &= \min_{u_n} [r(\mathbf{x}_n, u_n) + \min_{u_{n+1}} [r(\mathbf{x}_{n+1}, u_{n+1}) + J^*(\mathbf{x}_{n+2}, n+2)]] \\ &= \min_{u_n} [r(\mathbf{x}_n, u_n) + \min_{u_{n+1}} [r(\mathbf{x}_{n+1}, u_{n+1}) + \dots]] \end{aligned} \quad (10.80)$$

However, a difficulty resides frequently in the formulation of a given problem in an adequate form for the solution by means of dynamic programming and, with the actual progress of numerical calculation and nonlinear constrained optimization methods, the latter are nowadays more employed. A variant of dynamic programming [Luus, 1990] called iterative dynamic programming can often provide good results with a lighter computational effort [Luus, 1993, 1994, Luus and Bojkov, 1994].

10.4.2 Hamilton-Jacobi-Bellman Equation

Given the initial state \mathbf{x}_0 at time t_0 , considering the state \mathbf{x} and the control u , the optimal trajectory corresponds to the couple (\mathbf{x}, u) such that

$$J^*(\mathbf{x}_0, t_0) = \min_{u(t)} J(\mathbf{x}_0, u, t_0) \quad (10.81)$$

thus the optimal criterion does not depend on the control u .

In an interval $[t, t + \Delta t]$, the Bellman optimality principle as given in the recurrent Eq. (10.79) can be formulated as

$$J^*(\mathbf{x}(t), t) = \min_{u(t)} \left\{ \int_t^{t+\Delta t} r(\mathbf{x}, u, \tau) d\tau + J^*(\mathbf{x}(t + \Delta t), t + \Delta t) \right\} \quad (10.82)$$

This can be expressed in continuous form as a Taylor series expansion in the neighbourhood of the state $\mathbf{x}(t)$ and time t

$$J^*(\mathbf{x}(t), t) = \min_{u(t)} \left\{ \begin{array}{l} r(\mathbf{x}, u, t) \Delta t + J^*(\mathbf{x}(t), t) + \frac{\partial J^*}{\partial t} \Delta t + \\ \left(\frac{\partial J^*}{\partial \mathbf{x}} \right)^T f(\mathbf{x}, u, t) \Delta t + 0(\Delta t) \end{array} \right\} \quad (10.83)$$

Taking the limit when $\Delta t \rightarrow 0$ results in the Hamilton-Jacobi-Bellman equation

$$-\frac{\partial J^*}{\partial t} = \min_{u(t)} \left\{ r(\mathbf{x}, u, t) + \left(\frac{\partial J^*}{\partial \mathbf{x}} \right)^T f(\mathbf{x}, u, t) \right\} \quad (10.84)$$

As the optimal criterion does not depend on control u , it yields $J^*(\mathbf{x}(t_f), t_f) = W(\mathbf{x}(t_f))$, which gives the boundary condition for the Hamilton-Jacobi-Bellman Eq. (10.84)

$$J^*(\mathbf{x}, t_f) = W(\mathbf{x}) \quad , \quad \forall \mathbf{x} \quad (10.85)$$

The solution of Eq. (10.84) is the optimal control law

$$u^* = g\left(\frac{\partial J^*}{\partial \mathbf{x}}, \mathbf{x}, t\right) \quad (10.86)$$

which, when introduced into Eq. (10.84) gives

$$-\frac{\partial J^*}{\partial t} = r(\mathbf{x}, g, t) + \left(\frac{\partial J^*}{\partial \mathbf{x}}\right)^T f(\mathbf{x}, g, t) \quad (10.87)$$

whose solution is $J^*(\mathbf{x}, t)$ subject to the boundary condition (10.85). Equation (10.87) should be compared to the Hamilton-Jacobi Eq. (10.43). Then, the gradient $\partial J^*/\partial \mathbf{x}$ should be calculated and returned in (10.86), which gives the optimal state-feedback control law

$$u^* = g\left(\frac{\partial J^*}{\partial \mathbf{x}}, \mathbf{x}, t\right) = h(\mathbf{x}, t) \quad (10.88)$$

This corresponds to a closed-loop optimal control law given as a state feedback.

10.5 Linear Quadratic Control

Among the numerous publications concerning linear optimal control, are, in particular, the books by Anderson and Moore [1971, 1990], Athans and Falb [1966], Bryson and Ho [1975], Grimble and Johnson [1988a,b], Kirk [1970], Kwakernaak and Sivan [1972], Lewis [1986], and more recently, in robust control Maciejowski [1989]. Furthermore, among reference papers, cite Kalman [1960, 1963], Kalman and Bucy [1961]. Even, [Pannocchia et al., 2005] proposed constrained linear quadratic control to replace the classical PID control for which they see no advantage. Linear quadratic control is presented here in the previously discussed general framework of optimal control (see [Corriou, 2004] for more description with detailed examples).

10.5.1 Continuous-Time Linear Quadratic Control

In continuous time, the system is represented in the state space by the deterministic linear model

$$\begin{cases} \dot{\mathbf{x}}(t) = \mathbf{A} \mathbf{x}(t) + \mathbf{B} \mathbf{u}(t) \\ \mathbf{y}(t) = \mathbf{C} \mathbf{x}(t) \end{cases} \quad (10.89)$$

where \mathbf{u} is the control vector of dimension n_u , \mathbf{x} the state vector of dimension n and \mathbf{y} the output vector of dimension n_y . \mathbf{A} , \mathbf{B} , \mathbf{C} , are matrices of respective sizes $n \times n$, $n \times n_u$, $n_y \times n$.

The control \mathbf{u} must minimize the classical quadratic criterion

$$J = 0.5 \mathbf{x}^T(t_f) \mathbf{Q}_f \mathbf{x}(t_f) + 0.5 \int_{t_0}^{t_f} [\mathbf{x}^T(t) \mathbf{Q} \mathbf{x}(t) + \mathbf{u}^T(t) \mathbf{R} \mathbf{u}(t)] dt \quad (10.90)$$

where matrices \mathbf{Q}_f , \mathbf{Q} , are symmetrical semipositive definite, whereas \mathbf{R} is symmetrical positive definite. This criterion tends to bring the state \mathbf{x} towards 0. The first part of the criterion represents the performance whereas the second part is the energy spent to bring the state toward zero. Several cases can be distinguished with respect to the criterion according to whether the final time t_f is fixed or free and the final state is fixed or free [Bryson and Ho, 1975, Kirk, 1970].

Other criteria have been derived from the original criterion by replacing the state \mathbf{x} by \mathbf{z} with $\mathbf{z} = \mathbf{M}\mathbf{x}$, where \mathbf{z} represents a linear combination of the states, e.g. a measurement, or the output if $\mathbf{M} = \mathbf{C}$. The problem is then the regulation of \mathbf{z} . It is possible to incorporate the tracking of a reference trajectory $\mathbf{z}^r = \mathbf{M}\mathbf{x}^r$ by replacing the state \mathbf{x} with the tracking error $(\mathbf{z}^r - \mathbf{z})$.

Thus, the most general criterion can be considered, which takes into account the different previous cases

$$\begin{aligned} J &= 0.5 (\mathbf{z}^r - \mathbf{z})^T(t_f) \mathbf{Q}_f (\mathbf{z}^r - \mathbf{z})(t_f) \\ &+ 0.5 \int_{t_0}^{t_f} [(\mathbf{z}^r - \mathbf{z})^T(t) \mathbf{Q} (\mathbf{z}^r - \mathbf{z})(t) + \mathbf{u}^T(t) \mathbf{R} \mathbf{u}(t)] dt \end{aligned} \quad (10.91)$$

or

$$\begin{aligned} J &= 0.5 (\mathbf{x}^r - \mathbf{x})^T(t_f) \mathbf{M}^T \mathbf{Q}_f \mathbf{M} (\mathbf{x}^r - \mathbf{x})(t_f) \\ &+ 0.5 \int_{t_0}^{t_f} [(\mathbf{x}^r - \mathbf{x})^T(t) \mathbf{M}^T \mathbf{Q} \mathbf{M} (\mathbf{x}^r - \mathbf{x})(t) + \mathbf{u}^T(t) \mathbf{R} \mathbf{u}(t)] dt \end{aligned} \quad (10.92)$$

The matrices \mathbf{Q}_f , \mathbf{Q} , \mathbf{R} must have dimensions adapted to the retained criterion.

According to the techniques of variational calculation applied to optimal control, in particular Hamilton-Jacobi method, introduce the Hamiltonian as in Eq. (10.29)

$$H = -0.5 [(\mathbf{x}^r - \mathbf{x})^T(t) \mathbf{M}^T \mathbf{Q} \mathbf{M} (\mathbf{x}^r - \mathbf{x})(t) + \mathbf{u}^T(t) \mathbf{R} \mathbf{u}(t)] + \boldsymbol{\psi}^T(t) [\mathbf{A} \mathbf{x} + \mathbf{B} \mathbf{u}] \quad (10.93)$$

The Hamilton canonical Eqs. (10.30) provide, besides the state Eq. (10.89), the derivative of the costate vector

$$-\frac{\partial H}{\partial \mathbf{x}} = \dot{\boldsymbol{\psi}}(t) = -\mathbf{M}^T \mathbf{Q} \mathbf{M} (\mathbf{x}^r - \mathbf{x}) - \mathbf{A}^T \boldsymbol{\psi} \quad (10.94)$$

with the final transversality condition (assuming that the state \mathbf{x}_f is free, that is, not constrained)

$$\boldsymbol{\psi}(t_f) = \mathbf{M}^T \mathbf{Q}_f \mathbf{M} (\mathbf{x}^r - \mathbf{x})_f \quad (10.95)$$

Moreover, in the absence of constraints, the condition of maximization of the Hamiltonian with respect to \mathbf{u} gives

$$\frac{\partial H}{\partial \mathbf{u}} = 0 = -\mathbf{R} \mathbf{u} + \mathbf{B}^T \boldsymbol{\psi} \quad (10.96)$$

hence the optimal control

$$\mathbf{u}(t) = \mathbf{R}^{-1} \mathbf{B}^T \boldsymbol{\psi}(t) \quad (10.97)$$

Moreover, it can be noticed that $\mathbf{H}_{uu} = -\mathbf{R}$, which is thus symmetric negative, so that the Hamiltonian is maximum at the optimal control.

Gathering all these results, the system to be solved becomes a two-point boundary-value problem

$$\begin{aligned} \begin{bmatrix} \dot{\mathbf{x}}(t) \\ \dot{\boldsymbol{\psi}}(t) \end{bmatrix} &= \begin{bmatrix} \mathbf{A} & \mathbf{B} \mathbf{R}^{-1} \mathbf{B}^T \\ \mathbf{M}^T \mathbf{Q} \mathbf{M} & -\mathbf{A}^T \end{bmatrix} \begin{bmatrix} \mathbf{x}(t) \\ \boldsymbol{\psi}(t) \end{bmatrix} - \begin{bmatrix} 0 & 0 \\ \mathbf{M}^T \mathbf{Q} \mathbf{M} & 0 \end{bmatrix} \begin{bmatrix} \mathbf{x}^r(t) \\ 0 \end{bmatrix} \\ \mathbf{x}(t_0) &= \mathbf{x}_0 \\ \boldsymbol{\psi}(t_f) &= \mathbf{M}^T \mathbf{Q}_f \mathbf{M} (\mathbf{x}^r - \mathbf{x})_f \end{aligned} \quad (10.98)$$

Regulation Case: $\mathbf{x}^r = 0$

A classical approach consists of introducing the transition matrix corresponding to the previous differential system, which can be partitioned such that

$$\begin{bmatrix} \mathbf{x}(\tau) \\ \boldsymbol{\psi}(\tau) \end{bmatrix} = \begin{bmatrix} \Phi_{xx}(\tau, t) & \Phi_{x\psi}(\tau, t) \\ \Phi_{\psi x}(\tau, t) & \Phi_{\psi\psi}(\tau, t) \end{bmatrix} \begin{bmatrix} \mathbf{x}(t) \\ \boldsymbol{\psi}(t) \end{bmatrix}, \quad \tau \in [t, t_f] \quad (10.99)$$

This equation can be used at the final instant $\tau = t_f$ (where $\boldsymbol{\psi}(t_f)$ is known) thus

$$\begin{aligned} \mathbf{x}(t_f) &= \Phi_{xx}(t_f, t) \mathbf{x}(t) + \Phi_{x\psi}(t_f, t) \boldsymbol{\psi}(t) \\ \boldsymbol{\psi}(t_f) &= \Phi_{\psi x}(t_f, t) \mathbf{x}(t) + \Phi_{\psi\psi}(t_f, t) \boldsymbol{\psi}(t) \end{aligned} \quad (10.100)$$

hence

$$\begin{aligned} \boldsymbol{\psi}(t) &= -[\Phi_{\psi\psi}(t_f, t) + \mathbf{M}^T \mathbf{Q}_f \mathbf{M} \Phi_{x\psi}(t_f, t)]^{-1} \\ &\quad [\Phi_{\psi x}(t_f, t) + \mathbf{M}^T \mathbf{Q}_f \mathbf{M} \Phi_{xx}(t_f, t)] \mathbf{x}(t) \end{aligned} \quad (10.101)$$

a relation which can be denoted by

$$\boldsymbol{\psi}(t) = -\mathbf{M}^T \mathbf{S}(t) \mathbf{M} \mathbf{x}(t) = -\mathbf{P}_c(t) \mathbf{x}(t) \quad (10.102)$$

both to express the proportionality and to verify the terminal condition (at t_f), \mathbf{M} being any constant matrix. The subscript c of \mathbf{P}_c means that we are treating the control problem (to be compared with \mathbf{P}_f later used for Kalman filtering). The relation (10.102) is also called a backward sweep solution [Bryson, 1999].

This relation joined to the optimal control expression gives

$$\mathbf{u}^*(t) = -\mathbf{R}^{-1} \mathbf{B}^T \mathbf{M}^T \mathbf{S}(t) \mathbf{M} \mathbf{x}(t) = -\mathbf{R}^{-1} \mathbf{B}^T \mathbf{P}_c(t) \mathbf{x}(t) \quad (10.103)$$

which shows that this is a state feedback control. By setting $\mathbf{M} = \mathbf{I}$, we find the classical formula which equals $\mathbf{P}_c(t)$ and $\mathbf{S}(t)$

$$\mathbf{u}^*(t) = -\mathbf{R}^{-1} \mathbf{B}^T \mathbf{S}(t) \mathbf{x}(t) \quad (10.104)$$

In fact, the matrix $\mathbf{P}_c(t)$ can be calculated directly. Use the relation

$$\boldsymbol{\psi}(t) = -\mathbf{P}_c(t) \mathbf{x}(t) \quad (10.105)$$

inside the system (10.98). The continuous differential Riccati equation results

$$\begin{aligned} \dot{\mathbf{P}}_c(t) &= -\mathbf{P}_c(t) \mathbf{A} - \mathbf{A}^T \mathbf{P}_c(t) + \mathbf{P}_c(t) \mathbf{B} \mathbf{R}^{-1} \mathbf{B}^T \mathbf{P}_c(t) - \mathbf{M}^T \mathbf{Q} \mathbf{M} \\ \text{with: } \mathbf{P}_c(t_f) &= \mathbf{M}^T \mathbf{Q}_f \mathbf{M} \end{aligned} \quad (10.106)$$

where the matrix $\mathbf{P}_c(t)$ is symmetrical semipositive definite. Knowing the solution of this differential equation, the optimal control law can be calculated

$$\mathbf{u}^*(t) = -\mathbf{R}^{-1} \mathbf{B}^T \mathbf{P}_c(t) \mathbf{x}(t) = -\mathbf{K}_c(t) \mathbf{x}(t) \quad (10.107)$$

Notice that the differential Riccati equation (10.106), being known by its final condition, can be integrated backwards to deduce $\mathbf{P}_c(t_0)$, which will allow us to exploit the optimal control law in relation to the differential system (10.89).

If the horizon t_f is infinite, the control law is

$$\mathbf{u}^*(t) = -\mathbf{R}^{-1} \mathbf{B}^T \mathbf{P}_c \mathbf{x}(t) \quad (10.108)$$

where the matrix \mathbf{P}_c is the solution of the algebraic Riccati equation

$$\mathbf{P}_c \mathbf{A} + \mathbf{A}^T \mathbf{P}_c - \mathbf{P}_c \mathbf{B} \mathbf{R}^{-1} \mathbf{B}^T \mathbf{P}_c + \mathbf{M}^T \mathbf{Q} \mathbf{M} = 0 \quad (10.109)$$

which is the steady-state form of the differential Riccati Eq. (10.106). In this case, the condition $\mathbf{P}_c(t_f) = \mathbf{M}^T \mathbf{Q}_f \mathbf{M}$ disappears. Noting $\mathbf{P}_{c,\infty}$ the solution of the algebraic Riccati equation, the constant gain results

$$\mathbf{K}_{c,\infty} = \mathbf{R}^{-1} \mathbf{B}^T \mathbf{P}_{c,\infty} \quad (10.110)$$

hence the constant state-variable feedback

$$\mathbf{u}(t) = -\mathbf{K}_{c,\infty} \mathbf{x}(t) \quad (10.111)$$

so that the plant dynamics is

$$\dot{\mathbf{x}}(t) = (\mathbf{A} - \mathbf{B} \mathbf{K}_{c,\infty}) \mathbf{x}(t) \quad (10.112)$$

Noting $\sqrt{\mathbf{Q}}$ ("square root" of \mathbf{Q}) the matrix such that $\mathbf{Q} = \sqrt{\mathbf{Q}}^T \sqrt{\mathbf{Q}}$, the stabilization of the system is guaranteed if the pair $(\sqrt{\mathbf{Q}}, \mathbf{A})$ is observable and the pair (\mathbf{Q}, \mathbf{A}) is stabilizable, Riccati eq. (10.109) possesses a unique solution and the closed loop plant $(\mathbf{A} - \mathbf{B} \mathbf{K}_{c,\infty})$ is asymptotically stable. Compared to the variable gain $\mathbf{K}_c(t)$, the constant gain $\mathbf{K}_{c,\infty}$ is sub-optimal, but when t_f becomes large the gain $\mathbf{K}_c(t)$ tends toward $\mathbf{K}_{c,\infty}$.

Different methods have been published to solve Eq. (10.109), which poses serious numerical problems. A solution can be to integrate backward the differential Riccati equation (10.106) until a stationary solution is obtained. Another solution, which is numerically robust and is based on a Schur decomposition method, is proposed by Arnold and Laub [1984], Laub [1979].

A matrix \mathbf{A} of dimension $(2n \times 2n)$ is called Hamiltonian if $\mathbf{J}^{-1} \mathbf{A}^T \mathbf{J} = -\mathbf{A}$ or $\mathbf{J} = -\mathbf{A}^{-T} \mathbf{J} \mathbf{A}$, where \mathbf{J} is equal to: $\begin{bmatrix} \mathbf{0} & \mathbf{I} \\ \mathbf{I} & \mathbf{0} \end{bmatrix}$. An important property

[Laub, 1979] of Hamiltonian matrices is that if λ is an eigenvalue of a Hamiltonian matrix, $-\lambda$ is also an eigenvalue with the same multiplicity.

Consider the Hamiltonian matrix \mathcal{H}

$$\mathcal{H} = \begin{bmatrix} \mathbf{A} & -\mathbf{B}\mathbf{R}^{-1}\mathbf{B}^T \\ -\mathbf{M}^T\mathbf{Q}\mathbf{M} & -\mathbf{A}^T \end{bmatrix} \quad (10.113)$$

whose eigenvalues and eigenvectors are sought. Order the matrix \mathbf{U} of the eigenvectors of the Hamiltonian matrix of dimension $2n \times 2n$ in such a way that the first n columns are the eigenvectors corresponding to the stable eigenvalues (negative real or complex with a negative real part), in the form

$$\mathbf{U} = \begin{bmatrix} \mathbf{U}_{11} & \mathbf{U}_{12} \\ \mathbf{U}_{21} & \mathbf{U}_{22} \end{bmatrix} \quad (10.114)$$

where the blocks \mathbf{U}_{ij} have dimension $n \times n$. The solution to the algebraic Riccati equation (10.109) is then

$$\mathbf{P}_c = \mathbf{U}_{21}\mathbf{U}_{11}^{-1} \quad (10.115)$$

Note that the stationary solution to this problem can also be obtained by iterative methods [Arnold and Laub, 1984].

The stable eigenvalues of the Hamiltonian matrix \mathcal{H} are the poles of the optimal closed loop system

$$\dot{\mathbf{x}}(t) = (\mathbf{A} - \mathbf{B}\mathbf{K}_c)\mathbf{x}(t) \quad (10.116)$$

Tracking Case: $\mathbf{x}^r \neq 0$

In the presence of the tracking term \mathbf{x}^r , the differential system (10.98) is not homogeneous anymore, and it is necessary to add a term to (10.99), as

$$\begin{bmatrix} \mathbf{x}(\tau) \\ \boldsymbol{\psi}(\tau) \end{bmatrix} = \begin{bmatrix} \boldsymbol{\Phi}_{xx}(\tau, t) & \boldsymbol{\Phi}_{x\psi}(\tau, t) \\ \boldsymbol{\Phi}_{\psi x}(\tau, t) & \boldsymbol{\Phi}_{\psi\psi}(\tau, t) \end{bmatrix} \begin{bmatrix} \mathbf{x}(t) \\ \boldsymbol{\psi}(t) \end{bmatrix} + \begin{bmatrix} \mathbf{g}_x(\tau, t) \\ \mathbf{g}_\psi(\tau, t) \end{bmatrix} \quad (10.117)$$

In the same manner as previously, at the final instant $\tau = t_f$, we obtain

$$\begin{aligned} \mathbf{x}(t_f) &= \boldsymbol{\Phi}_{xx}(t_f, t)\mathbf{x}(t) + \boldsymbol{\Phi}_{x\psi}(t_f, t)\boldsymbol{\psi}(t) + \mathbf{g}_x(t_f, t) \\ \boldsymbol{\psi}(t_f) &= \boldsymbol{\Phi}_{\psi x}(t_f, t)\mathbf{x}(t) + \boldsymbol{\Phi}_{\psi\psi}(t_f, t)\boldsymbol{\psi}(t) + \mathbf{g}_\psi(t_f, t) \end{aligned} \quad (10.118)$$

hence

$$\begin{aligned} \boldsymbol{\psi}(t) &= -[\boldsymbol{\Phi}_{\psi\psi}(t_f, t) + \mathbf{M}^T\mathbf{Q}_f\mathbf{M}\boldsymbol{\Phi}_{x\psi}(t_f, t)]^{-1} \\ &\quad \left\{ [\boldsymbol{\Phi}_{\psi x}(t_f, t) + \mathbf{M}^T\mathbf{Q}_f\mathbf{M}\boldsymbol{\Phi}_{xx}(t_f, t)]\mathbf{x}(t) + \right. \\ &\quad \left. \mathbf{M}^T\mathbf{Q}_f\mathbf{M}(\mathbf{g}_x(t_f, t) - \mathbf{x}_{r,f}) + \mathbf{g}_\psi(t_f, t) \right\} \end{aligned} \quad (10.119)$$

giving an expression in the form

$$\boldsymbol{\psi}(t) = -\mathbf{P}_c(t)\mathbf{x}(t) + \mathbf{s}(t) \quad (10.120)$$

By introducing this expression in (10.94), we again get the differential Riccati Eq. (10.106) whose matrix \mathbf{P}_c is a solution, with the same terminal condition. Moreover, we obtain the differential equation giving the vector \mathbf{s}

$$\begin{aligned} \dot{\mathbf{s}}(t) &= [\mathbf{P}_c(t) \mathbf{B} \mathbf{R}^{-1} \mathbf{B}^T - \mathbf{A}^T] \mathbf{s}(t) - \mathbf{M}^T \mathbf{Q} \mathbf{M} \mathbf{x}^r \\ \text{with: } \mathbf{s}(t_f) &= \mathbf{M}^T \mathbf{Q}_f \mathbf{M} \mathbf{x}_f^r \end{aligned} \quad (10.121)$$

This equation is often termed feedforward. Like the differential Riccati Eq. (10.106), it must be integrated backward in time, so that both equations must be integrated off-line before implementing the control and require the knowledge of the future reference trajectory, thus posing a problem for actual on-line implementation, which will lead to the sub-optimal solutions to avoid this difficulty [Lewis, 1986]. Knowing the solutions of this differential equation and of the differential Riccati Eq. (10.106), the optimal control law can be calculated and applied

$$\mathbf{u}^*(t) = -\mathbf{R}^{-1} \mathbf{B}^T \mathbf{P}_c(t) \mathbf{x}(t) + \mathbf{R}^{-1} \mathbf{B}^T \mathbf{s}(t) = \mathbf{u}_{fb}(t) + \mathbf{u}_{ff}(t) \quad (10.122)$$

In this form, $\mathbf{u}_{fb}(t)$ represents a state feedback control (term in $\mathbf{x}(t)$), as the gain \mathbf{K}_c depends at each instant on the solution of the Riccati equation, and $\mathbf{u}_{ff}(t)$ represents a feedforward control (term in $\mathbf{s}(t)$). This structure is visible in Fig. 10.3. The practical use of the linear quadratic regulator is thus decomposed into two parts, according to a hierarchical manner, first off-line calculation of the optimal gain, then actual control using feedback.

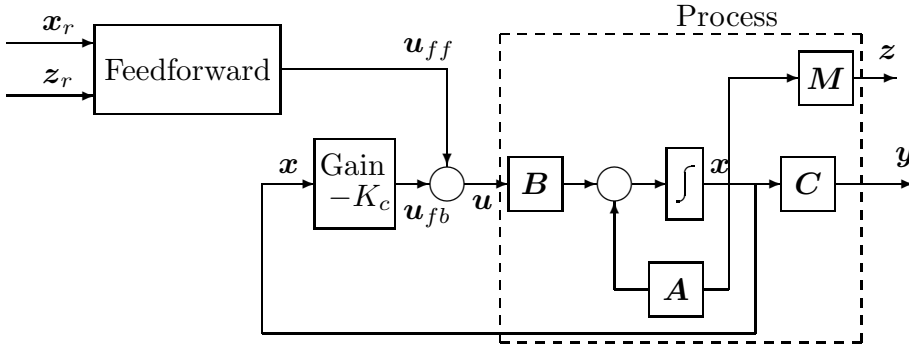

Figure 10.1: Structure of linear quadratic control

In the same manner as in regulation, when the horizon is infinite, \mathbf{P}_c is solution of the algebraic Riccati equation (10.109) and \mathbf{s} is solution of the algebraic equation

$$\mathbf{s} = [\mathbf{P}_c \mathbf{B} \mathbf{R}^{-1} \mathbf{B}^T - \mathbf{A}^T]^{-1} \mathbf{M}^T \mathbf{Q} \mathbf{M} \mathbf{x}^r \quad (10.123)$$

This solution is frequently adopted in actual practice.

Lin [1994] recommends choosing, as a first approach, diagonal criterion weighting matrices with their diagonal terms equal to

$$q_i = 1/(z_i)_{\max}^2, \quad r_i = 1/(u_i)_{\max}^2 \quad (10.124)$$

in order to realize a compromise between the input variations and the performance with respect to the output, while Anderson and Moore [1990] propose taking

$$q_i = 1/ \int_0^\infty z_i^2 dt, \quad r_i = 1/ \int_0^\infty u_i^2 dt \quad (10.125)$$

It frequently happens, as in the simple linear example previously treated, that some components of the control vector are bounded

$$|u_i| \leq u_{i,\max} \quad (10.126)$$

In this case, the optimal control is equal to

$$\mathbf{u}^* = \text{sat}(\mathbf{R}^{-1} \mathbf{B}^T \boldsymbol{\psi}) \quad (10.127)$$

defining the saturation function by

$$\text{sat}(u_i) = \begin{cases} u_i & \text{if: } |u_i| \leq u_{i,\max} \\ u_{i,\max} & \text{if: } |u_i| \geq u_{i,\max} \end{cases} \quad (10.128)$$

Linear Quadratic Control of a Chemical Reactor

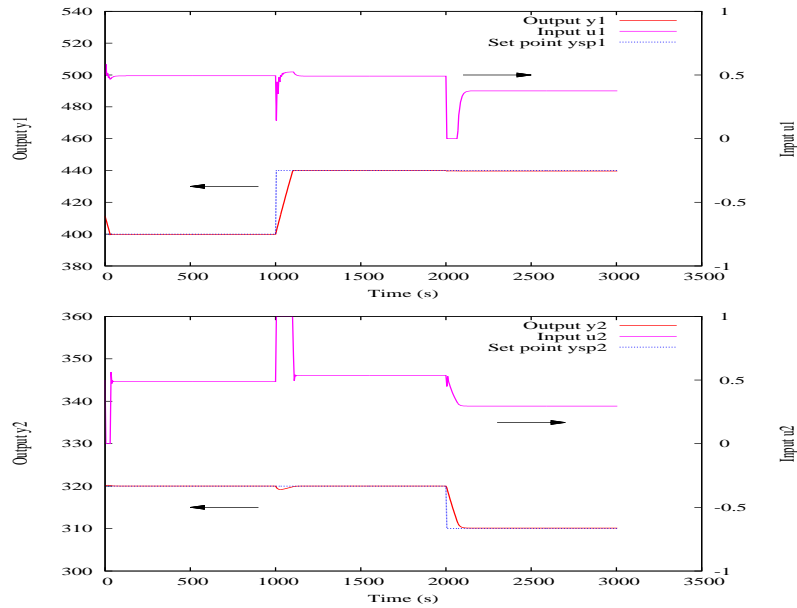

Figure 10.2: Linear quadratic control of chemical reactor (criterion weighting: $\mathbf{Q} = 0.1 \mathbf{I}$; $\mathbf{R} = \mathbf{I}$). Top: input u_1 and output y_1 (concentration of A). Bottom: input u_2 and output y_2 (reactor temperature)

A continuous perfectly stirred chemical reactor [Corriou, 2004] is modelled with four states (x_1 , concentration of A, x_2 , reactor temperature, x_3 , jacket

temperature, x_4 , liquid volume), two manipulated inputs corresponding to valve positions that allow to control the inlet temperature in the jacket $T_{j,in}$ and the feed concentration $C_{A,f}$ respectively, two controlled outputs, the concentration of A and the reactor temperature respectively. The nonlinear model of the reactor is:

$$\begin{aligned}\dot{x}_1 &= \frac{F_f}{x_4} (C_{A,f} - x_1) - k x_1 \\ \dot{x}_2 &= \frac{F_f}{x_4} (T_f - x_2) - \frac{\Delta H k x_1}{\rho C_p} - \frac{UA(x_2 - x_3)}{\rho C_p x_4} \\ \dot{x}_3 &= \frac{F_j}{V_j} (T_{j,in} - x_3) + \frac{UA(x_2 - x_3)}{\rho_j C_{pj} V_j} \\ \dot{x}_4 &= F_f - F_{sp} + K_r (V_{sp} - x_4) y_1 = x_1 \\ y_2 &= x_2\end{aligned}\quad (10.129)$$

with:

$$k = k_0 \exp\left(-\frac{E_a}{R x_2}\right); \quad C_{A,f} = u_2 C_{A,f}; \quad T_{j,in} = u_1 T_{hot} + (1 - u_1) T_{cold}\quad (10.130)$$

where T_{cold} and T_{hot} are the temperatures of two cold and hot heat exchangers assumed constant. The volume x_4 is controlled independently by a proportional controller. Both manipulated inputs are bounded in the interval $[0, 1]$.

The physical parameters of the chemical reactor are given in Table 10.1.

The linearized model of the chemical reactor calculated at initial time and maintained constant during the study is given in the state space by

$$\begin{aligned}\mathbf{A} &= \begin{bmatrix} -0.0010 & -0.0254 & 0 & -0.2052 \\ 0 & -0.0036 & 0.0040 & 0.0048 \\ 0 & -0.4571 & -0.0429 & 0 \\ 0 & 0 & 0 & -0.05 \end{bmatrix} & \mathbf{B} &= \begin{bmatrix} 0 & 0.78 \\ 0 & 0 \\ 40 & 0 \\ 0 & 0 \end{bmatrix} \\ \mathbf{C} &= \begin{bmatrix} 1 & 0 & 0 & 0 \\ 0 & 1 & 0 & 0 \end{bmatrix} & \mathbf{D} &= \begin{bmatrix} 0 & 0 \\ 0 & 0 \end{bmatrix}\end{aligned}\quad (10.131)$$

The form (10.92) of the quadratic criterion is here used with $\mathbf{M} = \mathbf{C}$. The linearized model is used to calculate the control law in terms of deviation variables which is then applied to the plant model which provides the values of the theoretical states. Due to the exothermic chemical reaction, this reactor exhibits a strongly nonlinear behavior. The matrix \mathbf{Q} is identity \mathbf{I} and matrix \mathbf{R} is $10\mathbf{I}$ giving more importance to robustness. This avoids too frequent variations of the manipulated inputs. The set point changes are decoupled. At $t = 1000\text{s}$ when the concentration set point variation occurs, the input u_2 used to control the inlet temperature in the jacket saturates due to the large exothermicity whereas at $t = 2000\text{s}$, when the temperature set point variation occurs, the input u_1 controlling the inlet concentration in the reactor saturates. This demonstrates the large coupling between concentration and temperature due to the reaction exothermicity. In spite of these limitations, the LQ control law allows to perfectly control this nonlinear plant which is very representative of the behavior of an actual perfectly stirred chemical reactor.

Table 10.1: Initial variables and main parameters of the CSTR

Flow rate of the feed	$F_f = F_{sp} = 3 \times 10^{-4} \text{ m}^3 \cdot \text{s}^{-1}$
Concentration of reactant A in the feed	$C_{A,f} = 3900 \text{ mol} \cdot \text{m}^{-3}$
Temperature of the feed	$T_f = 295 \text{ K}$
Volume of reactor	$V(t=0) = V_{sp} = 1.5 \text{ m}^3$
Kinetic constant	$k_0 = 2 \times 10^8 \cdot \text{s}^{-1}$
Activation energy	$E = 7 \times 10^4 \text{ J} \cdot \text{mol}^{-1}$
Heat of reaction	$\Delta H = -7 \times 10^4 \text{ J} \cdot \text{mol}^{-1}$
Density of reactor contents	$\rho = 1000 \text{ kg} \cdot \text{m}^{-3}$
Heat capacity of reactor contents	$C_p = 3000 \text{ J} \cdot \text{kg}^{-1} \cdot \text{K}^{-1}$
Temperature of the cold heat exchanger	$T_c = 280 \text{ K}$
Temperature of hot heat exchanger	$T_h = 360 \text{ K}$
Flow rate of the heat-conducting fluid	$F_j = 5 \times 10^{-2} \text{ m}^3 \cdot \text{s}^{-1}$
Volume of jacket	$V_j = 0.1 \text{ m}^3$
Heat transfer coefficient between the jacket and the reactor contents	$U = 900 \text{ W} \cdot \text{m}^{-2} \cdot \text{K}^{-1}$
Heat-exchange area	$A = 20 \text{ m}^2$
Density of the heat-conducting fluid	$\rho_j = 1000 \text{ kg} \cdot \text{m}^{-3}$
Heat capacity of the heat-conducting fluid	$C_{pj} = 4200 \text{ J} \cdot \text{kg}^{-1} \cdot \text{K}^{-1}$
Proportional gain of the level controller	$K_r = 0.05 \text{ s}^{-1}$

10.5.2 Linear Quadratic Gaussian Control

In linear quadratic control, such as was previously discussed, the states are assumed to be perfectly known. In fact, this is seldom the case. Indeed, often the states have no physical reality and, if they have one, frequently they are not measurable or unmeasured. Thus, it is necessary to estimate the states in order to use their estimation in the control model.

In continuous time, the system is represented in the state space by the stochastic linear model

$$\begin{cases} \dot{\mathbf{x}}(t) = \mathbf{A} \mathbf{x}(t) + \mathbf{B} \mathbf{u}(t) + \mathbf{w}(t) \\ \mathbf{y}(t) = \mathbf{C} \mathbf{x}(t) + \mathbf{v}(t) \end{cases} \quad (10.132)$$

where $\mathbf{w}(t)$ and $\mathbf{v}(t)$ are uncorrelated Gaussian white noises, respectively of state and measurement (or output), of the respective covariance matrices

$$\mathbb{E} \{ \mathbf{w} \mathbf{w}^T \} = \mathbf{W} \geq 0, \quad \mathbb{E} \{ \mathbf{v} \mathbf{v}^T \} = \mathbf{V} > 0 \quad (10.133)$$

Denote by $\hat{\mathbf{x}}$ the state estimation, so that the state reconstruction error is $\mathbf{e}(t) = \mathbf{x} - \hat{\mathbf{x}}$. An optimal complete observer such as

$$\dot{\hat{\mathbf{x}}} = \mathbf{A} \hat{\mathbf{x}}(t) + \mathbf{B} \mathbf{u}(t) + \mathbf{K}_f(t)[\mathbf{y}(t) - \mathbf{C} \hat{\mathbf{x}}(t)] \quad (10.134)$$

minimizes the covariance matrix of the state reconstruction error, thus

$$\mathbb{E} \{ (\mathbf{x} - \hat{\mathbf{x}}) \mathbf{P}_w (\mathbf{x} - \hat{\mathbf{x}})^T \} \quad (10.135)$$

where \mathbf{P}_w is a weighting matrix (possibly, the identity matrix).

Kalman and Bucy [1961] solved this problem and showed that the estimator gain matrix \mathbf{K}_f is equal to

$$\mathbf{K}_f(t) = \mathbf{P}_f(t) \mathbf{C}^T \mathbf{V}^{-1} \quad (10.136)$$

where $\mathbf{P}_f(t)$ is the solution of the continuous differential Riccati equation

$$\begin{aligned} \dot{\mathbf{P}}_f(t) &= \mathbf{A} \mathbf{P}_f(t) + \mathbf{P}_f(t) \mathbf{A}^T - \mathbf{P}_f(t) \mathbf{C}^T \mathbf{V}^{-1} \mathbf{C} \mathbf{P}_f(t) + \mathbf{W} \\ \text{with: } \mathbf{P}_f(t_0) &= \mathbf{P}_0 \end{aligned} \quad (10.137)$$

Moreover, the initial estimator condition is

$$\hat{\mathbf{x}}(t_0) = \hat{\mathbf{x}}_0 \quad (10.138)$$

The Kalman-Bucy filter thus calculated is the best state estimator or observer in the sense of linear least squares. It must be noticed that the determination of the Kalman filter is a dual problem of the linear quadratic optimal control problem: to go from the control problem to the estimation one, it suffices to make the following correspondences: $\mathbf{A} \rightarrow \mathbf{A}^T$, $\mathbf{B} \rightarrow \mathbf{C}^T$, $\mathbf{M}^T \mathbf{Q} \mathbf{M} \rightarrow \mathbf{W}$, $\mathbf{R} \rightarrow \mathbf{V}$, $\mathbf{P}_c \rightarrow \mathbf{P}_f$; on the one hand, the control Riccati equation progresses backwards with respect to time, on the other hand, the estimation Riccati equation progresses forwards with respect to time. This latter remark obliges us to carefully manipulate all time-dependent functions of the solutions of the Riccati equations [Kwakernaak and Sivan, 1972]: $\mathbf{P}_c(t)$ (control problem) is equal to $\mathbf{P}_f(t_0 + t_f - t)$ (estimation problem), where t_0 is the initial time of the estimation problem and t_f the final time of the control problem.

When the estimation horizon becomes very large, in general the solution of the Riccati Eq. (10.137) tends towards a steady-state value, corresponding to the solution of the following algebraic Riccati equation

$$\mathbf{A} \mathbf{P}_f + \mathbf{P}_f \mathbf{A}^T - \mathbf{P}_f \mathbf{C}^T \mathbf{V}^{-1} \mathbf{C} \mathbf{P}_f + \mathbf{W} = 0 \quad (10.139)$$

giving the steady-state gain matrix of the estimator

$$\mathbf{K}_f = \mathbf{P}_f \mathbf{C}^T \mathbf{V}^{-1} \quad (10.140)$$

Kwakernaak and Sivan [1972] detail the conditions of convergence. For reasons of duality, the solving of the algebraic Riccati equation (10.139) is completely similar to that of Eq. (10.109).

Consider the general case of tracking. The control law similar to (10.122) is now based on the state estimation

$$\mathbf{u}^*(t) = -\mathbf{R}^{-1} \mathbf{B}^T \mathbf{P}_c(t) \hat{\mathbf{x}}(t) + \mathbf{R}^{-1} \mathbf{B}^T \mathbf{s}(t) = -\mathbf{K}_c \hat{\mathbf{x}}(t) + \mathbf{u}_{ff}(t) \quad (10.141)$$

The system state equation can be written as

$$\dot{\mathbf{x}}(t) = \mathbf{A} \mathbf{x}(t) - \mathbf{B} \mathbf{K}_c(t) \hat{\mathbf{x}}(t) + \mathbf{B} \mathbf{u}_{ff}(t) + \mathbf{w}(t) \quad (10.142)$$

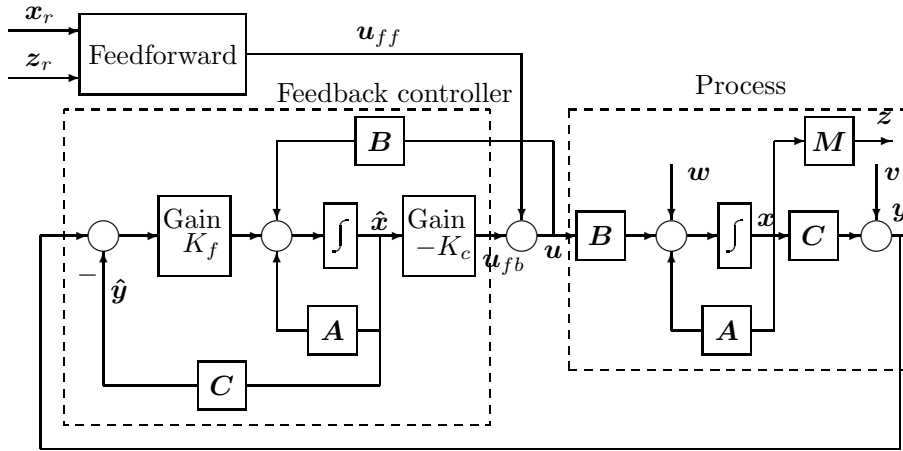

Figure 10.3: Structure of linear quadratic Gaussian control

so that the complete scheme of the Kalman filter and state feedback optimal control (Fig. ??) is written as

$$\begin{bmatrix} \dot{\hat{x}} \\ \dot{\hat{x}} \end{bmatrix} = \begin{bmatrix} \mathbf{A} & -\mathbf{B}\mathbf{K}_c \\ \mathbf{K}_f\mathbf{C} & \mathbf{A} - \mathbf{K}_f\mathbf{C} - \mathbf{B}\mathbf{K}_c \end{bmatrix} \begin{bmatrix} \mathbf{x} \\ \hat{\mathbf{x}} \end{bmatrix} + \begin{bmatrix} \mathbf{B}\mathbf{u}_{ff}(t) + \mathbf{w} \\ \mathbf{B}\mathbf{u}_{ff}(t) + \mathbf{K}_f\mathbf{v} \end{bmatrix} \quad (10.143)$$

which can be transformed by use of the estimation error $\mathbf{e}(t) = \mathbf{x}(t) - \hat{\mathbf{x}}(t)$

$$\begin{bmatrix} \dot{\hat{x}} \\ \dot{\mathbf{e}} \end{bmatrix} = \begin{bmatrix} \mathbf{A} - \mathbf{B}\mathbf{K}_c & \mathbf{B}\mathbf{K}_c \\ \mathbf{0} & \mathbf{A} - \mathbf{K}_f\mathbf{C} \end{bmatrix} \begin{bmatrix} \mathbf{x} \\ \mathbf{e} \end{bmatrix} + \begin{bmatrix} \mathbf{B}\mathbf{u}_{ff}(t) + \mathbf{w} \\ \mathbf{w} - \mathbf{K}_f\mathbf{v} \end{bmatrix} \quad (10.144)$$

The closed-loop eigenvalues are the union of the eigenvalues of the state feedback optimal control scheme and the eigenvalues of Kalman filter. Thus, it is possible to separately determine the observer and the state feedback optimal control law, which constitutes the separation principle of linear quadratic Gaussian control. This property that we have just verified for a complete observer is also verified for a reduced observer.

It is useful to notice that the Kalman filter gain is proportional to \mathbf{P} (which will vary, but must be initialized) and inversely proportional to the measurement covariance matrix \mathbf{V} . Thus, if \mathbf{V} is low, the filter gain will be very large, as the confidence in the measurement will be large; the risk of low robustness is then high. The Kalman filter can strongly deteriorate the stability margins [Doyle, 1978]. The characteristic matrices of the Kalman filter can also be considered as tuning parameters. It is also possible to introduce an integrator per input-output channel in order to effectively realize the set point tracking; the modelled system represents, in this case, the group of the process plus the integrators. It is possible to add an output feedback [Lin, 1994] according to Fig. 10.4, which improves the robustness of regulation and tracking.

[Lewis, 1992] discusses in detail the problem of the linear quadratic regulator

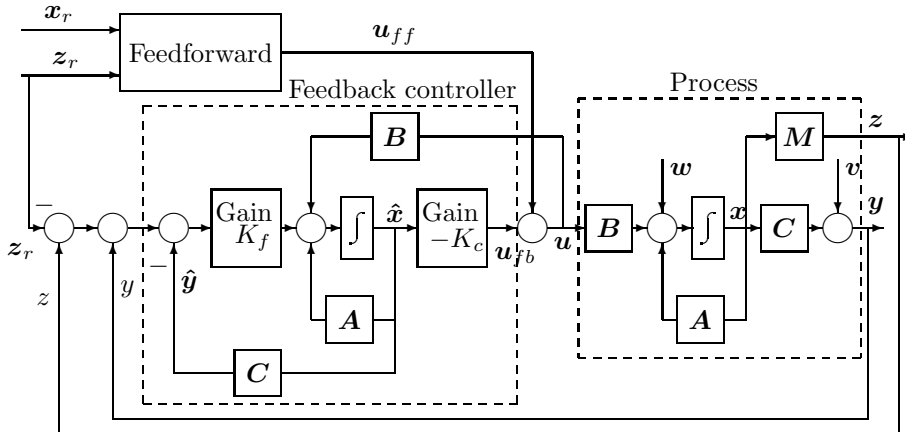

Figure 10.4: Structure of linear quadratic Gaussian control with added output feedback

with output feedback set as

$$u = -K y \quad (10.145)$$

which is more difficult to solve than the classical state feedback, but presents much practical interest. The problem results in a Lyapunov equation that can be solved.

In several applications, LQG revealed that it was sensitive to system uncertainty, so that new approaches were necessary. An important development in LQG control is the consideration of robustness so as to satisfy frequency criteria concerning the sensitivity and complementary sensitivity functions, or gain and phase margins. Actually, the stability margins of LQG control may reveal themselves to be insufficient. LQG/LTR (Loop Transfer Recovery) means use of the LQG design together with a robust control design [Athans, 1986, Kwakernaak, 1993, Lewis, 1992, Maciejowski, 1989, Stein and Athans, 1987], thus it guarantees closed-loop robustness, both as performance and stability robustness. However, the increase of robustness by use of LQG/LTR results unavoidably in a decrease of performance which can be handled by special optimization techniques [Apkarian and Noll, 2006].

Linear Quadratic Gaussian Control of a Chemical Reactor

The same chemical reactor as for linear quadratic control is used to evaluate linear quadratic Gaussian control. The same set points are imposed. In this case, the theoretical states describe the behavior of the plant but noisy measurements are used as process outputs. The standard deviations of concentration and temperature are equal to 2 and 0.5, respectively.

The same control law as for LQ control is used, but it here takes into account the estimated states which themselves depend on the noisy measurements. Two types of Kalman estimators have been used to estimate the states. The linear Kalman filter based on the constant linear model of the plant, calculated at initial time, resulted in deviations of the outputs with respect to the set points.

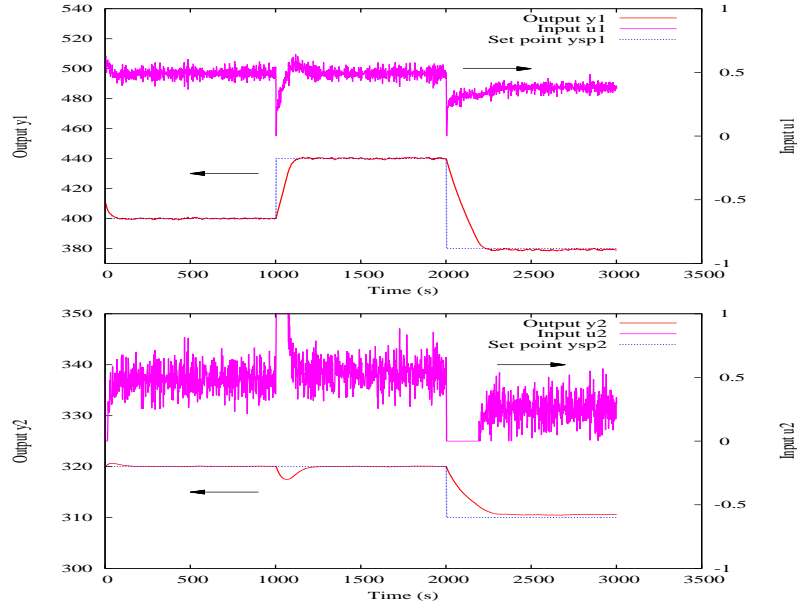

Figure 10.5: Linear quadratic Gaussian control of chemical reactor (criterion weighting: $\mathbf{Q} = 0.02 \mathbf{I}$; $\mathbf{R} = \mathbf{I}$). Top: input u_1 and output y_1 (concentration of A). Bottom: input u_2 and output y_2 (reactor temperature)

To avoid these deviations and better estimate the states, an extended Kalman filter was used. It is based on the linearized model of the process which is no more constant, being updated at each sampling period equal to 10s, and takes better into account the strong nonlinearity of the process due to a large exothermicity. The matrix \mathbf{Q} is identity \mathbf{I} and matrix \mathbf{R} is augmented as $50\mathbf{I}$ to avoid too large moves of the manipulated inputs. The Kalman matrices are $\mathbf{W} = 0.001\mathbf{I}$, $\mathbf{V} = 0.05\mathbf{I}$ and $\mathbf{P} = \mathbf{I}$, except the last diagonal term equal to 0.1 for this latter. On Figure 10.5, it is clear that the inputs still show relatively large variations, in particular u_2 , but if \mathbf{R} is still augmented, the performance is degraded and larger deviations between the controlled outputs and the set points, especially temperature, are observed. An output feedback such as (10.145) could be used, but it was not implemented here to demonstrate the potential of LQG control. Globally, in spite of a strongly nonlinear process, LQG control is very satisfactory.

10.5.3 Discrete-Time Linear Quadratic Control

In discrete time, the system is represented in the state space by the deterministic linear model

$$\begin{cases} \mathbf{x}_{k+1} &= \mathbf{F} \mathbf{x}_k + \mathbf{G} \mathbf{u}_k \\ \mathbf{y}_k &= \mathbf{H} \mathbf{x}_k \end{cases} \quad (10.146)$$

The sought control must minimize a quadratic criterion similar to Eq. (10.91) thus

$$\begin{aligned}
J &= 0.5 [\mathbf{z}_N^r - \mathbf{z}_N]^T \mathbf{Q}_N [\mathbf{z}_N^r - \mathbf{z}_N] \\
&+ 0.5 \sum_{k=0}^{N-1} \{ [\mathbf{z}_k^r - \mathbf{z}_k]^T \mathbf{Q} [\mathbf{z}_k^r - \mathbf{z}_k] + \mathbf{u}_k^T \mathbf{R} \mathbf{u}_k \} \\
&= 0.5 [\mathbf{x}_N^r - \mathbf{x}_N]^T \mathbf{M}^T \mathbf{Q}_N \mathbf{M} [\mathbf{x}_N^r - \mathbf{x}_N] \\
&+ 0.5 \sum_{k=0}^{N-1} \{ [\mathbf{x}_k^r - \mathbf{x}_k]^T \mathbf{M}^T \mathbf{Q} \mathbf{M} [\mathbf{x}_k^r - \mathbf{x}_k] + \mathbf{u}_k^T \mathbf{R} \mathbf{u}_k \}
\end{aligned} \tag{10.147}$$

where the matrices \mathbf{Q}_N , \mathbf{Q} are semipositive definite and \mathbf{R} is positive definite. Furthermore $\mathbf{z} = \mathbf{M}\mathbf{x}$ represents measurements or outputs. It would be possible to use variational methods to deduce from them the optimal control law [Borne et al., 1990, Lewis, 1986], which would provide a system perfectly similar to Eq. (10.98). However, variational methods are a priori designed in the framework of continuous variables, thus for continuous time; on the other hand, dynamic programming is perfectly adapted to the discrete case. Thus, we will sketch out the reasoning in this framework. For more details, it is possible, for example, to refer to Dorato and Levis [1971], Foulard et al. [1987].

The system is considered at any instant i included in the interval $[0, N]$, assuming that the policy preceding that instant, thus the sequence of the $\{\mathbf{u}_k, k \in [i+1, N]\}$, is optimal (the final instant N is the starting point for performing the procedure of dynamic programming). In these conditions, the criterion of interest is in the form

$$\begin{aligned}
J_i &= 0.5 [\mathbf{z}_N^r - \mathbf{z}_N]^T \mathbf{Q}_N [\mathbf{z}_N^r - \mathbf{z}_N] \\
&+ 0.5 \sum_{k=i}^{N-1} \{ [\mathbf{z}_k^r - \mathbf{z}_k]^T \mathbf{Q} [\mathbf{z}_k^r - \mathbf{z}_k] + \mathbf{u}_k^T \mathbf{R} \mathbf{u}_k \} \\
&= 0.5 [\mathbf{x}_N^r - \mathbf{x}_N]^T \mathbf{M}^T \mathbf{Q}_N \mathbf{M} [\mathbf{x}_N^r - \mathbf{x}_N] + \sum_{k=i}^{N-1} L_k(\mathbf{x}_k, \mathbf{u}_k)
\end{aligned} \tag{10.148}$$

with the revenue function L_k defined by

$$L_k(\mathbf{x}_k, \mathbf{u}_k) = 0.5 \left\{ [\mathbf{x}_k^r - \mathbf{x}_k]^T \mathbf{M}^T \mathbf{Q} \mathbf{M} [\mathbf{x}_k^r - \mathbf{x}_k] + \mathbf{u}_k^T \mathbf{R} \mathbf{u}_k \right\} \tag{10.149}$$

According to Bellman optimality principle, the optimal value J_i^* of the criterion can be expressed in a recurrent form

$$J_i^* = \min_{\mathbf{u}} \left\{ 0.5 [\mathbf{x}_i^r - \mathbf{x}_i]^T \mathbf{M}^T \mathbf{Q} \mathbf{M} [\mathbf{x}_i^r - \mathbf{x}_i] + \mathbf{u}_i^T \mathbf{R} \mathbf{u}_i + J_{i+1}^* \right\} \tag{10.150}$$

The final state is assumed to be free. It is necessary to know the expression of J_{i+1}^* with respect to the state to be able to perform the minimization. Reasoning by recurrence, suppose that it is in quadratic form

$$J_{i+1}^* = 0.5 \left\{ \mathbf{x}_{i+1}^T \mathbf{S}_{i+1} \mathbf{x}_{i+1} + 2 \mathbf{g}_{i+1} \mathbf{x}_{i+1} + h_{i+1} \right\} \tag{10.151}$$

hence

$$J_{i+1}^* = 0.5 \{ [\mathbf{F} \mathbf{x}_i + \mathbf{G} \mathbf{u}_i]^T \mathbf{S}_{i+1} [\mathbf{F} \mathbf{x}_i + \mathbf{G} \mathbf{u}_i] + 2 \mathbf{g}_{i+1} [\mathbf{F} \mathbf{x}_i + \mathbf{G} \mathbf{u}_i] + h_{i+1} \} \quad (10.152)$$

We deduce

$$J_i^* = 0.5 \min_{\mathbf{u}_i} \left\{ [\mathbf{x}_i^r - \mathbf{x}_i]^T \mathbf{M}^T \mathbf{Q} \mathbf{M} [\mathbf{x}_i^r - \mathbf{x}_i] + \mathbf{u}_i^T \mathbf{R} \mathbf{u}_i + [\mathbf{F} \mathbf{x}_i + \mathbf{G} \mathbf{u}_i]^T \mathbf{S}_{i+1} [\mathbf{F} \mathbf{x}_i + \mathbf{G} \mathbf{u}_i] + 2 \mathbf{g}_{i+1} [\mathbf{F} \mathbf{x}_i + \mathbf{G} \mathbf{u}_i] + h_{i+1} \right\} \quad (10.153)$$

We search the minimum with respect to \mathbf{u}_i thus

$$\mathbf{R} \mathbf{u}_i^* + \mathbf{G}^T \mathbf{S}_{i+1} [\mathbf{F} \mathbf{x}_i + \mathbf{G} \mathbf{u}_i^*] + \mathbf{G}^T \mathbf{g}_{i+1} = 0 \quad (10.154)$$

or

$$\mathbf{u}_i^* = -[\mathbf{R} + \mathbf{G}^T \mathbf{S}_{i+1} \mathbf{G}]^{-1} [\mathbf{G}^T \mathbf{S}_{i+1} \mathbf{F} \mathbf{x}_i + \mathbf{G}^T \mathbf{g}_{i+1}] \quad (10.155)$$

provided that the matrix $[\mathbf{R} + \mathbf{G}^T \mathbf{S}_{i+1} \mathbf{G}]$ is invertible. Notice that the optimal control is in the form

$$\mathbf{u}_i^* = -\mathbf{K}_i \mathbf{x}_i + \mathbf{k}_i \mathbf{g}_{i+1} \quad (10.156)$$

revealing the state feedback with the gain matrix \mathbf{K}_i and feedforward with the gain \mathbf{k}_i . Thus, we set

$$\begin{aligned} \mathbf{K}_i &= [\mathbf{R} + \mathbf{G}^T \mathbf{S}_{i+1} \mathbf{G}]^{-1} \mathbf{G}^T \mathbf{S}_{i+1} \mathbf{F}; & \mathbf{S}_N &= \mathbf{M}^T \mathbf{Q}_N \mathbf{M} \\ \mathbf{k}_i &= -[\mathbf{R} + \mathbf{G}^T \mathbf{S}_{i+1} \mathbf{G}]^{-1} \mathbf{G}^T \end{aligned} \quad (10.157)$$

It is then possible to verify that J_i^* is effectively in quadratic form; thus we find

$$\begin{aligned} \mathbf{S}_i &= \mathbf{M}^T \mathbf{Q} \mathbf{M} + \mathbf{F}^T \mathbf{S}_{i+1} (\mathbf{F} - \mathbf{G} \mathbf{K}_i) \\ \mathbf{g}_i &= -\mathbf{M}^T \mathbf{Q} \mathbf{z}_i^r + (\mathbf{F}^T - \mathbf{G} \mathbf{K}_i)^T \mathbf{g}_{i+1}; & \mathbf{g}_N &= \mathbf{M} \mathbf{Q}_N \mathbf{z}_N^r \end{aligned} \quad (10.158)$$

The group of Eqs. (10.156), (10.157), (10.158) allows us to determine the inputs \mathbf{u} . When not all states are known, of course it is necessary to use a discrete Kalman filter which will work with the optimal control law according to the same separation principle as in the continuous case.

It can be shown that Eq. (10.158) is equivalent to the discrete differential Riccati equation

$$\mathbf{S}_i = (\mathbf{F} - \mathbf{G} \mathbf{K}_i)^T \mathbf{S}_{i+1} (\mathbf{F} - \mathbf{G} \mathbf{K}_i) + \mathbf{K}_i^T \mathbf{R} \mathbf{K}_i + \mathbf{M}^T \mathbf{Q} \mathbf{M} \quad (10.159)$$

here presented in Joseph form and better adapted to numerical calculation.

Let us apply the Hamilton-Jacobi principle to the discrete-time optimal regulator. If the control law \mathbf{u}_i^* and the corresponding states \mathbf{x}_i^* are optimal, according to the Hamilton-Jacobi principle, there exists a costate vector $\boldsymbol{\psi}_i^*$

such that \mathbf{u}_i^* is the value of the control \mathbf{u}_i which maximizes the Hamiltonian function H_a

$$\begin{aligned} H_a &= -L_i(\mathbf{x}_i^*, \mathbf{u}_i) + \boldsymbol{\psi}_{i+1}^{*T} \mathbf{x}_{i+1} \\ &= -L_i(\mathbf{x}_i^*, \mathbf{u}_i) + \boldsymbol{\psi}_{i+1}^{*T} [\mathbf{F} \mathbf{x}_i + \mathbf{G} \mathbf{u}_i] \\ &= -0.5 \left\{ [\mathbf{x}_i^r - \mathbf{x}_i]^T \mathbf{M}^T \mathbf{Q} \mathbf{M} [\mathbf{x}_i^r - \mathbf{x}_i] + \mathbf{u}_i^T \mathbf{R} \mathbf{u}_i \right\} + \boldsymbol{\psi}_{i+1}^{*T} [\mathbf{F} \mathbf{x}_i + \mathbf{G} \mathbf{u}_i] \end{aligned} \quad (10.160)$$

The Hamilton-Jacobi conditions give

$$\boldsymbol{\psi}_i^* = -\frac{\partial H_a}{\partial \mathbf{x}_i^*} = \mathbf{M}^T \mathbf{Q} \mathbf{M} [\mathbf{x}_i^* - \mathbf{x}_i^r] - \mathbf{F}^T \boldsymbol{\psi}_{i+1} \quad \text{with: } \boldsymbol{\psi}_N = \mathbf{M}^T \mathbf{Q} \mathbf{M} [\mathbf{x}_N^* - \mathbf{x}_N^r] \quad (10.161)$$

and the control which maximizes the Hamiltonian function H_a is such that

$$\frac{dH_a}{d\mathbf{u}_i} = 0 \implies -\mathbf{R} \mathbf{u}_i + \mathbf{G}^T \boldsymbol{\psi}_{i+1} = 0 \implies \mathbf{u}_i^* = \mathbf{R}^{-1} \mathbf{G}^T \boldsymbol{\psi}_{i+1} \quad (10.162)$$

hence

$$\mathbf{x}_{i+1} = \mathbf{F} \mathbf{x}_i + \mathbf{G} \mathbf{u}_i = \mathbf{F} \mathbf{x}_i + \mathbf{G} \mathbf{R}^{-1} \mathbf{G}^T \boldsymbol{\psi}_{i+1} \quad (10.163)$$

Introduce the matrix \mathcal{H} such that

$$\begin{bmatrix} \mathbf{x}_i \\ \boldsymbol{\psi}_i \end{bmatrix} = \mathcal{H} \begin{bmatrix} \mathbf{x}_{i+1} \\ \boldsymbol{\psi}_{i+1} \end{bmatrix} \quad \text{or:} \quad \begin{bmatrix} \mathbf{x}_{i+1} \\ \boldsymbol{\psi}_{i+1} \end{bmatrix} = \mathcal{H}^{-1} \begin{bmatrix} \mathbf{x}_i \\ \boldsymbol{\psi}_i \end{bmatrix} \quad (10.164)$$

Assume $\mathbf{x}_i^r = 0$ for the regulation case. The two conditions (10.161) and (10.162) can be grouped as

$$\begin{aligned} \boldsymbol{\psi}_i^* &= \mathbf{M}^T \mathbf{Q} \mathbf{M} \mathbf{x}_i^* - \mathbf{F}^T \boldsymbol{\psi}_{i+1} \\ \mathbf{x}_{i+1} &= \mathbf{F} \mathbf{x}_i + \mathbf{G} \mathbf{R}^{-1} \mathbf{G}^T \boldsymbol{\psi}_{i+1} \end{aligned} \quad (10.165)$$

from which we deduce the matrix \mathcal{H}

$$\mathcal{H} = \begin{bmatrix} \mathbf{F}^{-1} & -\mathbf{F}^{-1} \mathbf{G} \mathbf{R}^{-1} \mathbf{G}^T \\ \mathbf{M}^T \mathbf{Q} \mathbf{M} \mathbf{F}^{-1} & -\mathbf{F}^T - \mathbf{M}^T \mathbf{Q} \mathbf{M} \mathbf{F}^{-1} \mathbf{G} \mathbf{R}^{-1} \mathbf{G}^T \end{bmatrix} \quad (10.166)$$

In the case where a steady-state gain \mathbf{K}_∞ is satisfactory, which can be realized when the horizon N is large, the gain matrix can be obtained after solving the algebraic Riccati equation

$$\mathbf{S} = \mathbf{F}^T [\mathbf{S} - \mathbf{S} \mathbf{G} (\mathbf{G}^T \mathbf{S} \mathbf{G} + \mathbf{R})^{-1} \mathbf{G}^T \mathbf{S}] \mathbf{F} + \mathbf{M} \mathbf{Q} \mathbf{M} \quad (10.167)$$

whose solution (corresponding to discrete time) is obtained in a parallel manner to the continuous case, by first considering the matrix \mathcal{H} . Its inverse is the symplectic matrix \mathcal{H}^{-1} equal to

$$\mathcal{H}^{-1} = \begin{bmatrix} \mathbf{F} + \mathbf{G} \mathbf{R}^{-1} \mathbf{G}^T \mathbf{F}^{-T} \mathbf{M}^T \mathbf{Q} \mathbf{M} & -\mathbf{G} \mathbf{R}^{-1} \mathbf{G}^T \mathbf{F}^{-T} \\ \mathbf{F}^{-T} \mathbf{M}^T \mathbf{Q} \mathbf{M} & -\mathbf{F}^{-T} \end{bmatrix} \quad (10.168)$$

A matrix \mathbf{A} is symplectic, when, given the matrix $\mathbf{J} = \begin{bmatrix} \mathbf{0} & \mathbf{I} \\ -\mathbf{I} & \mathbf{0} \end{bmatrix}$, the matrix \mathbf{A} verifies $\mathbf{A}^T \mathbf{J} \mathbf{A} = \mathbf{J}$. If λ is an eigenvalue of a symplectic matrix \mathbf{A} , $1/\lambda$ is also an eigenvalue of \mathbf{A} ; λ is thus also an eigenvalue of \mathbf{A}^{-1} [Laub, 1979].

We seek the eigenvalues and associated eigenvectors of \mathcal{H}^{-1} . Then, we form the matrix \mathbf{U} of the eigenvectors so that the first n columns correspond to the stable eigenvalues (inside the unit circle), in the form

$$\mathbf{U} = \begin{bmatrix} \mathbf{U}_{11} & \mathbf{U}_{12} \\ \mathbf{U}_{21} & \mathbf{U}_{22} \end{bmatrix} \quad (10.169)$$

where the blocks \mathbf{U}_{ij} have dimension $n \times n$. The solution of the discrete Riccati algebraic equation (10.167) is then

$$\mathbf{S}_\infty = \mathbf{U}_{21} \mathbf{U}_{11}^{-1} \quad (10.170)$$

giving the steady-state matrix.

For the tracking problem, in parallel to the stationary solution for the gain matrix \mathbf{K} , the stationary solution for the feedforward gain is deduced from Eq. (10.158) and is given by

$$\mathbf{g}_i = [\mathbf{I} - (\mathbf{F}^T - \mathbf{G} \mathbf{K}_\infty)^T]^{-1} [-\mathbf{M}^T \mathbf{Q} \mathbf{z}_i^r] \quad (10.171)$$

The use of stationary gains provides a sub-optimal solution but is more robust than using the optimal gains coming from Eqs. (10.157) and (10.158).

The discrete linear quadratic Gaussian control is derived from the previously described discrete linear quadratic control by coupling a discrete linear Kalman filter in order to estimate the states.

Remark

Recall the operating conditions of quadratic control. In general, it is assumed that the pair (\mathbf{A}, \mathbf{B}) in continuous time, or (\mathbf{F}, \mathbf{G}) in discrete time, is controllable. Moreover, when the horizon is infinite and when we are looking for steady-state solutions of the Riccati equation, the condition that the pair $(\mathbf{A}, \sqrt{\mathbf{Q}})$ in continuous time, or $(\mathbf{F}, \sqrt{\mathbf{Q}})$ in discrete time, is observable (the notation $\mathbf{H} = \sqrt{\mathbf{Q}}$ means that $\mathbf{Q} = \mathbf{H}^T \mathbf{H}$) must be added.

References

- B.D.O. Anderson and J.B. Moore. *Linear Optimal Control*. Prentice Hall, Englewood Cliffs, New Jersey, 1971.
- B.D.O. Anderson and J.B. Moore. *Optimal Control, Linear Quadratic Methods*. Prentice Hall, Englewood Cliffs, New Jersey, 1990.
- P. Apkarian and D. Noll. Nonsmooth H_∞ synthesis. *IEEE Transactions on Automatic Control*, AC-51:71–86, 2006.

- R. Aris. Studies in optimization. II. Optimal temperature gradients in tubular reactors. *Chem. Eng. Sci.*, 13(1):18–29, 1960.
- R. Aris. *The Optimal Design of Chemical Reactors: A Study in Dynamic Programming*. Academic Press, New York, 1961.
- R. Aris, D.F. Rudd, and N.R. Amundson. On optimum cross current extraction. *Chem. Eng. Sci.*, 12:88–97, 1960.
- W.F. Arnold and A.J. Laub. Generalized eigenproblem algorithms and software for algebraic Riccati equations. *IEEE Proceedings*, 72(12):1746–1754, 1984.
- M. Athans. A tutorial on the lqg/ltr method. Technical Report LIDS-P;1542, Laboratory for Information and Decision Systems, Massachusetts Institute of Technology, 1986.
- M. Athans and P.L. Falb. *Optimal Control: An Introduction to the Theory and its Applications*. Mac Graw Hill, New York, 1966.
- J.R. Banga and E.F. Carrasco. Rebuttal to the comments of Rein Luus on "Dynamic optimization of batch reactors using adaptive stochastic algorithms". *Ind. Eng. Chem. res.*, 37:306–307, 1998.
- R. Bellman. *Dynamic Programming*. Princeton University Press, Princeton, New Jersey, 1957.
- R. Bellman and S. Dreyfus. *Applied Dynamic Programming*. Princeton University Press, Princeton, New Jersey, 1962.
- L.T. Biegler. Solution of dynamic optimization problems by successive quadratic programming and orthogonal collocation. *Comp. Chem. Eng.*, 8:243–248, 1984.
- B. Bojkov and R. Luus. Optimal control of nonlinear systems with unspecified final times. *Chem. Eng. Sci.*, 51(6):905–919, 1996.
- P. Borne, G. Dauphin-Tanguy, J.P. Richard, F. Rotella, and I. Zambettakis. *Commande et Optimisation des Processus*. Technip, Paris, 1990.
- R. Boudarel, J. Delmas, and P. Guichet. *Commande Optimale des Processus*. Dunod, Paris, 1969.
- A.E. Bryson. *Dynamic Optimization*. Addison Wesley, Menlo Park, California, 1999.
- A.E. Bryson and Y.C. Ho. *Applied Optimal Control*. Hemisphere, Washington, 1975.
- E.F. Carrasco and J.R. Banga. Dynamic optimization of batch reactors using adaptive stochastic algorithms. *Ind. Eng. Chem. Res.*, 36:2252–2261, 1997.

- J.P. Corriou. *Process Control - Theory and Applications*. Springer, London, 2004.
- J.P. Corriou. *Commande des Procédés*. Lavoisier, Tec. & Doc., Paris, third edition, 2012.
- J. Dorato and A.H. Levis. *IEEE Trans. A. C.*, AC-16(6):613–620, 1971.
- J.C. Doyle. Guaranteed margins for LQG regulators. *IEEE Trans. Automat. Control*, AC-23:756–757, 1978.
- A. Feldbaum. *Principes Théoriques des Systèmes Asservis Optimaux*. Mir, Moscou, 1973. Edition Française.
- C. Foulard, S. Gentil, and J.P. Sandraz. *Commande et Régulation par Calculateur Numérique*. Eyrolles, Paris, 1987.
- C.J. Goh and K.L. Teo. Control parametrization: a unified approach to optimal control problems with general constraints. *Automatica*, 24:3–18, 1988.
- M.J. Grimble and M.A. Johnson. *Optimal Control and Stochastic Estimation: Deterministic Systems*, volume 1. Wiley, Chichester, 1988a.
- M.J. Grimble and M.A. Johnson. *Optimal Control and Stochastic Estimation: Stochastic Systems*, volume 2. Wiley, Chichester, 1988b.
- T. Kailath. *Linear Systems Theory*. Prentice Hall, Englewood Cliffs, New Jersey, 1980.
- R.E. Kalman. A new approach to linear filtering and prediction problems. *Trans. ASME Ser. D, J. Basic Eng.*, 82:35–45, 1960.
- R.E. Kalman. Mathematical description of linear dynamical systems. *J. SIAM Control*, series A:152–192, 1963.
- R.E. Kalman and R.S. Bucy. New results in linear filtering and prediction theory. *Trans. ASME Ser. D, J. Basic Eng.*, 83:95–108, 1961.
- A. Kaufmann and R. Cruon. *La Programmation Dynamique. Gestion Scientifique Séquentielle*. Dunod, Paris, 1965.
- D.E. Kirk. *Optimal Control Theory. An Introduction*. Prentice Hall, Englewood Cliffs, New Jersey, 1970.
- H. Kwakernaak. Robust control and \mathcal{H}_∞ -optimization – tutorial paper. *Automatica*, 29(2):255–273, 1993.
- H. Kwakernaak and R. Sivan. *Linear Optimal Control Systems*. Wiley-Interscience, New York, 1972.
- F. Lamnabhi-Lagarrigue. Singular optimal control problems: on the order of a singular arc. *Systems & control letters*, 9:173–182, 1987.

- A.J. Laub. A Schur method for solving algebraic Riccati equations. *IEEE Trans. Automat. Control*, AC-24(6):913–921, 1979.
- E.B. Lee and L. Markus. *Foundations of Optimal Control Theory*. Krieger, Malabar, Florida, 1967.
- F.L. Lewis. *Optimal Control*. Wiley, New York, 1986.
- F.L. Lewis. *Applied Optimal Control and Estimation*. Prentice Hall, Englewood Cliffs, New Jersey, 1992.
- C.F. Lin. *Advanced Control Systems Design*. Prentice Hall, Englewood Cliffs, New Jersey, 1994.
- R. Luus. Application of dynamic programming to high-dimensional nonlinear optimal control systems. *Int. J. Cont.*, 52(1):239–250, 1990.
- R. Luus. Application of iterative dynamic programming to very high-dimensional systems. *Hung. J. Ind. Chem.*, 21:243–250, 1993.
- R. Luus. Optimal control of bath reactors by iterative dynamic programming. *J. Proc. Cont.*, 4(4):218–226, 1994.
- R. Luus. Numerical convergence properties of iterative dynamic programming when applied to high dimensional systems. *Trans. IChemE, part A*, 74:55–62, 1996.
- R. Luus and B. Bojkov. Application of iterative dynamic programming to time-optimal control. *Chem. Eng. Res. Des.*, 72:72–80, 1994.
- R. Luus and D. Hennessy. Optimization of fed-batch reactors by the Luus-Jaakola optimization procedure. *Ind. Eng. Chem. Res.*, 38:1948–1955, 1999.
- J.M. Maciejowski. *Multivariable Feedback Design*. Addison-Wesley, Wokingham, England, 1989.
- W. Mekarapiruk and R. Luus. Optimal control of inequality state constrained systems. *Ind. Eng. Chem. Res.*, 36:1686–1694, 1997.
- G. Pannocchia, N. Laachi, and J.B. Rawlings. A candidate to replace PID control: SISO-constrained LQ control. *AIChE J.*, 51(4):1178–1189, 2005.
- L. Pontryaguine, V. Boltianski, R. Gamkrelidze, and E. Michtchenko. *Théorie Mathématique des Processus Optimaux*. Mir, Moscou, 1974. Edition Française.
- L. Pun. *Introduction à la Pratique de l’Optimisation*. Dunod, Paris, 1972.
- W.H. Ray and J. Szekeley. *Process Optimization with Applications in Metallurgy and Chemical Engineering*. Wiley, New York, 1973.
- S.M. Roberts. *Dynamic Programming in Chemical Engineering and Process Control*. Academic Press, New York, 1964.

- S.M. Roberts and C.G. Laspe. Computer control of a thermal cracking reaction. *Ind. Eng. Chem.*, 53(5):343–348, 1961.
- G. Stein and M. Athans. The LQG/LTR procedure for multivariable feedback control design. *IEEE Trans. Automat. Control*, AC-32(2):105–114, 1987.
- R.F. Stengel. *Optimal control and estimation*. Courier Dover Publications, 1994.
- K.L. Teo, C.J. Goh, and K.H. Wong. *A Unified Computational Approach to Optimal Control Problems*. Longman Scientific & Technical, Harlow, Essex, England, 1991.