



HAL
open science

Assessing metacommunity processes through signatures in spatiotemporal turnover of community composition

Franck Jabot, Fabien Laroche, François Massol, Florent Arthaud, Julie Crabot, Maxime Dubart, Simon Blanchet, François Munoz, Patrice David, T. Datry

► To cite this version:

Franck Jabot, Fabien Laroche, François Massol, Florent Arthaud, Julie Crabot, et al.. Assessing metacommunity processes through signatures in spatiotemporal turnover of community composition. Ecology Letters, 2020, 23 (9), pp.1330-1339. 10.1111/ele.13523 . hal-02942285

HAL Id: hal-02942285

<https://hal.science/hal-02942285>

Submitted on 5 Nov 2020

HAL is a multi-disciplinary open access archive for the deposit and dissemination of scientific research documents, whether they are published or not. The documents may come from teaching and research institutions in France or abroad, or from public or private research centers.

L'archive ouverte pluridisciplinaire **HAL**, est destinée au dépôt et à la diffusion de documents scientifiques de niveau recherche, publiés ou non, émanant des établissements d'enseignement et de recherche français ou étrangers, des laboratoires publics ou privés.



RESEARCH ARTICLE



Cite as: Jabot F, Laroche F, Massol F, Arthaud F, Crabot J, Dubart M, Blanchet S, Munoz F, David P, and Datry T. Assessing metacommunity processes through signatures in spatiotemporal turnover of community composition. bioRxiv 480335, ver. 3 peer-reviewed and recommended by PCI Ecology (2019).

Posted: 2nd September 2019

Recommender:
Werner Ulrich

Reviewers:
Joaquín Hortal and two anonymous reviewers

Correspondence:
franck.jabot@irstea.fr

Assessing metacommunity processes through signatures in spatiotemporal turnover of community composition

Franck Jabot¹, Fabien Laroche², François Massol^{3,4}, Florent Arthaud⁵, Julie Crabot⁶, Maxime Dubart⁷, Simon Blanchet⁸, François Munoz⁹, Patrice David⁷ & Thibault Datry⁶

¹ Université Clermont Auvergne, Irstea, UR LISC, Centre de Clermont-Ferrand, 9 avenue Blaise Pascal CS 20085, F-63178 Aubière, France

² Irstea, UR EFNO, Centre de Nogent-sur-Vernisson, Nogent-sur-Vernisson, France

³ Univ. Lille, CNRS, UMR 8198 - Evo-Eco-Paleo, SPICI group, F-59000 Lille, France

⁴ Univ. Lille, CNRS, Inserm, CHU Lille, Institut Pasteur de Lille, U1019 - UMR 8204 - CIIL - Center for Infection and Immunity of Lille, F-59000 Lille, France

⁵ Univ. Savoie Mont Blanc, INRA, CARRETEL, 74200 Thonon-les-Bains, France

⁶ Irstea, UR MALY, Centre de Lyon-Villeurbanne, 5 rue de la Doua, 69625 Villeurbanne Cedex, France

⁷ CEFE UMR 5175, CNRS - Université de Montpellier - Université Paul-Valéry Montpellier – IRD - EPHE, 1919 route de Mende, 34293 Montpellier cedex 5, France

⁸ CNRS, Université Toulouse III Paul Sabatier, Station d'Écologie Théorique et Expérimentale, UMR 5321, 2 route du CNRS, 09200 Moulis, France

⁹ University Grenoble-Alpes, LECA, Grenoble Cedex 9, France

This article has been peer-reviewed and recommended by
Peer Community in Ecology



ABSTRACT

Although metacommunity ecology has been a major field of research in the last decades, with both conceptual and empirical outputs, the analysis of the temporal dynamics of metacommunities has only emerged recently and still consists mostly of repeated static analyses. Here we propose a novel analysis framework to assess metacommunity processes using path analyses of spatial and temporal diversity turnovers. We detail the principles and practical aspects of this framework and apply it to simulated datasets to illustrate its ability to decipher the respective contributions of entangled drivers of metacommunity dynamics. We then apply it to four real datasets. Empirical results support the view that metacommunity dynamics may be generally shaped by multiple ecological processes acting in concert, with environmental filtering being variable across both space and time. These results reinforce our call to go beyond static analyses of metacommunities that are blind to the temporal part of environmental variability.

Keywords: beta-diversity; demographic stochasticity; dispersal limitation; environmental filtering; path analysis

Introduction

One of the main goals of community ecology is to understand the determinants of species diversity at different spatial scales. Based on the inspiring work of Skellam (1952), Preston (1962), MacArthur & Wilson (1967) and Shmida & Wilson (1985), metacommunity theory has emerged as a strong framework to investigate the spatial distribution of species and the dynamics of spatially structured ecosystems (Leibold et al. 2004, Loreau & Holt 2004 ; Massol et al. 2011, Guichard 2017). Metacommunity theory has been originally proposed to revolve around four main paradigms explaining the coexistence of species on patchy habitat landscapes (Leibold et al. 2004, Shoemaker & Melbourne 2016, Fournier et al. 2017; but see also criticism of Brown et al. 2017), which can be better understood as “templates” or typical cases in which a few processes dominate metacommunity assembly and functioning. The patch-dynamic paradigm focuses on the processes of competition, colonization and extinction in networks of patches that can be released due to intrinsic or extrinsic causes. In this paradigm, a particular emphasis is put on trade-offs to explain species coexistence at a large spatial scale, e.g. through the competition-colonization trade-off (Hastings 1980, Tilman 1994, Calcagno et al. 2006) or the tolerance-competition trade-off (Muller-Landau 2010, Haegeman et al. 2013). The species-sorting paradigm focuses on the differential responses of species, in terms of vital rates and biotic interactions, to environmental heterogeneity across the landscape to explain large-scale and local coexistence as the result of environmental filters and local adaptation (Chase & Leibold 2003). The mass-effect paradigm focuses on source-sink dynamics



among communities, with species potentially coexisting in patches where they are maladapted due to the important influx of dispersing individuals (Amarasekare & Nisbet 2001, Mouquet & Loreau 2003). Finally, the neutral paradigm focuses on the interplay of stochasticity and dispersal, in a simplified approach that does not consider differences of local adaptation between species, thus explaining local species coexistence as a purely stochastic process driven by species frequencies at a larger scale and immigration rates (Hubbell 2001). These four simplistic views of real metacommunities were defined to encompass the main models and assumptions on coexistence mechanisms, both in theory and in empirical studies (Cottenie 2005, Shoemaker & Melbourne 2016, Ulrich et al. 2017).

Metacommunity paradigms and their associated models have mostly been used to analyse spatial patterns of metacommunity composition at a single date, therefore assuming that metacommunities are at a dynamical equilibrium (Logue et al. 2011, Heino et al. 2015), often in an indirect manner (*i.e.* with statistical models quite disconnected from the theoretically grounded dynamical models; but see Azaee et al. 2006 for an exception). Specifically, when spatial environmental variation is hypothesized to play a role, the most common approach has been to perform variance partitioning (Borcard et al. 1992, Cottenie 2005, but see e.g., Leibold and Mikkelsen 2002, Ulrich et al. 2017). It consists in partitioning the observed spatial variation of community composition into spatial and environmental components, measured as multivariate matrices of relevant spatial and environmental explanatory variables respectively (Borcard et al. 1992, Cottenie 2005, Peres-Neto et al. 2006). The effect of the spatial component is then expected to reflect the combined effect of dispersal and ecological drift (neutral and/or patch dynamics and/or mass effect), while the effect of the environmental component should summarize differential species responses to environmental variation (species-sorting, see Cottenie 2005 for a classification). Such analyses of static spatial patterns of metacommunities have produced numerous ecological insights on the processes structuring metacommunities and their variation across biomes, taxa and along environmental gradients (Cottenie 2005, Henriques-Silva et al. 2013, Heino et al. 2015). However, results on simulated datasets challenge these findings and suggest that partitioning alone does not allow unambiguously grasping metacommunity dynamics (Gilbert & Bennett 2010, Peres-Neto & Legendre 2010). Here we address whether and how analysing temporal patterns of diversity in metacommunities allows better inferring their underlying processes.

Ecosystems and their constituent communities are highly dynamic (e.g., Brokaw 1985, Tschardt et al. 2005, Malard et al. 2006, Acuña et al. 2014, Bertrand et al. 2016), and this temporal variation in community processes is likely to impair the



analysis of metacommunity diversity at a single date. Temporal data, however, should provide key information on community processes and assembly dynamics (Anderson and Cribble 1998, Magurran and Henderson 2010, Wolkowich et al. 2014, Buckley et al. 2018), provided a method is able to process signal from noise in metacommunity time series. As a starting point, Box 1 summarizes how dispersal, ecological drift and ecological filtering should influence species turnover and lead to distinctive signatures (Massol and Petit 2013). Box 1 presents simple hypotheses that may apply to many ecological systems (but see some counter-examples in Box 1). While Box 1 is very general and does not provide a statistical framework *per se*, it points out predictable patterns that could be used to assess metacommunity processes from metacommunity time series. To date, few studies have examined the temporal dynamics of metacommunities (Datry et al. 2016). We here argue that this limited emphasis on the temporal dynamics of metacommunities reflects (i) a lack of a general quantitative framework to analyse temporal changes (but see e.g., Nuvoloni et al. 2016) and (ii) the scarcity of proper empirical datasets involving time series.

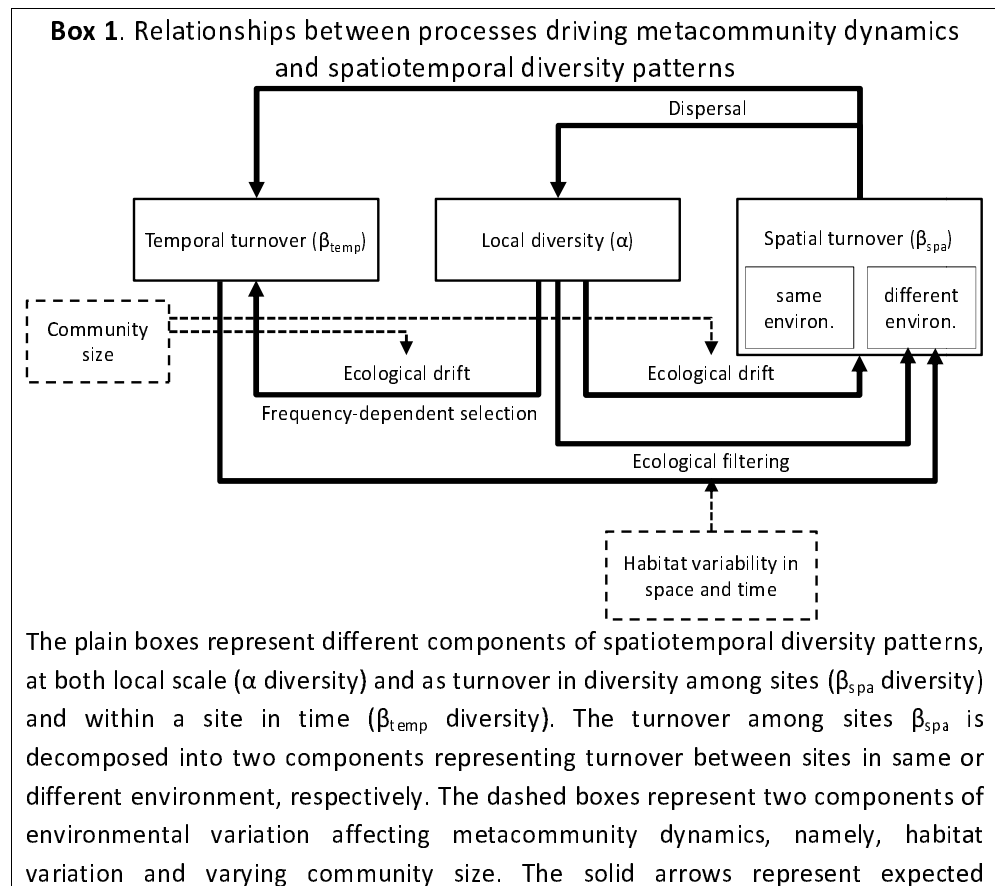



influences of the processes driving metacommunity dynamics on diversity patterns. The processes at play are labelled on each arrow, and the end of arrow represents expected increase while the origin represent expected decrease (the origin of the arrow) in patterns of corresponding boxes. For instance, dispersal is expected to decrease spatial turnover and to increase local diversity and temporal turnover. Dashed lines indicate how environmental variation mediates these effects: community size negatively affects ecological drift while habitat heterogeneity increases the effect of ecological filtering. Figure improved from an earlier version presented in Massol & Petit (2013).

Greater dispersal should entail higher local diversity (Shmida and Wilson 1985), higher temporal turnover (Nuvoloni et al. 2016) and generally lower spatial turnover (Shmida and Wilson 1985). Ecological drift should lower local diversity (Hubbell 2001), increase spatial turnover (Chave and Leigh 2002) and increase temporal turnover (Leigh et al. 1993). The strength of ecological drift should further be negatively related to the number of individuals in the local community (Hubbell 2001). Positive frequency-dependent selection should lower local diversity and increase temporal turnover (May 1973), the reverse being true for negative frequency-dependent selection (Janzen 1970). Ecological filtering should lower local diversity (Hutchinson 1957) and temporal turnover (Magurran and Henderson 2003), and increase spatial turnover between communities located in different environmental conditions (Whittaker 1967). Finally, habitat variability in space and time should increase the effects of ecological filtering (Chesson 2000).

Counter-examples to these general relationships may appear in specific systems. For instance, Vannette and Fukami (2017) studied nectar-inhibiting microbial communities and demonstrated that dispersal may enhance priority effects and spatial beta-diversity in this transient system that establishes in a previously empty habitat; Shmida and Wilson (1985) explained how dispersal (coupled to ecological filtering) may actually increase spatial turnover between communities experiencing similar environmental conditions if they are in peculiar landscape settings (see their Fig. 5); Molofsky et al. (2001) demonstrated how positive frequency-dependence may actually stabilize communities of sessile organisms with short interaction ranges.

Nuvoloni et al. (2016) proposed to analyse the temporal turnover of community composition and to relate local turnover to environmental variables. We here propose to generalize this approach with two novel ingredients. First, we suggest jointly analysing spatial and temporal turnovers of community composition: spatiotemporal turnover encompasses (i) temporal turnover of the different local communities, (ii) spatial turnover between different communities sampled at a given



date, and (iii) turnover between different communities sampled at different dates. A key argument is that these three components taken together can help tease apart ecological processes acting on communities through richer signatures than separate analyses of spatial and temporal turnovers (Box 1). Second, we propose to perform path analyses to study the influence of environmental, dispersal and community context on the three components simultaneously, so as to fully grasp the complex direct and indirect relationships among the drivers.

The comprehensive scheme of the expected influences of processes on spatiotemporal patterns (Box 1) provides the basis for a heuristic path model (Fig. 2). We predict that dispersal limitation and environmental filtering should cause a positive correlation between community dissimilarity and, respectively, geographical distance and environmental distance (Borcard et al. 1992). Second, demographic stochasticity should cause a negative correlation between mean community size and community dissimilarity, and a positive correlation between temporal distance and community dissimilarity (Lande et al. 2003). Third, differences in community size should be positively linked to differences in species richness (the more-individuals hypothesis, Srivastava & Lawton 1998), which in turn should cause an increase in community dissimilarity (due to its effect on nestedness, see Baselga 2010). Finally, we consider that environmental distance may be correlated with temporal and geographical distance. Our heuristic understanding of spatio-temporal community dissimilarity patterns makes use of both direct and indirect relationships between explanatory variables. Path analyses therefore constitute a natural way to perform an exploratory analysis of these putative drivers of metacommunity dynamics (Kingsolver & Schemske 1991). In particular systems deviating from the general relationships predicted by Box 1 (e.g., Shmida & Wilson 1985, Molofsky et al. 2001, Vannette & Fukami 2017), alternative heuristic path models can be used for such an analysis.

Here, we aim at testing this new analytical framework allowing a combined analysis of the spatial and temporal dynamics of metacommunities. We first use this framework to analyse simulated data, and demonstrate that it enables us to detect the signature of simulated processes. We then apply this framework to four real case studies. We find that multiple ecological processes are simultaneously influencing community dynamics and that the environmental conditions that influence community dynamics are generally both spatially and temporally structured.



Figure 2. Heuristic path model to test the signature of ecological processes on spatiotemporal diversity patterns

A dashed (resp. plain) arrow represents a negative (resp. positive) correlation. $\langle J \rangle$ stands for the average community size in the metacommunity, t for time, x for space, E for the local environment and S for species richness. Δ values represent difference of statistics in space and time. For instance, because it controls the intensity of ecological drift, the average community size is expected to negatively affect spatial and temporal diversity turnovers (negative arrow between $\langle J \rangle$ and β diversity).

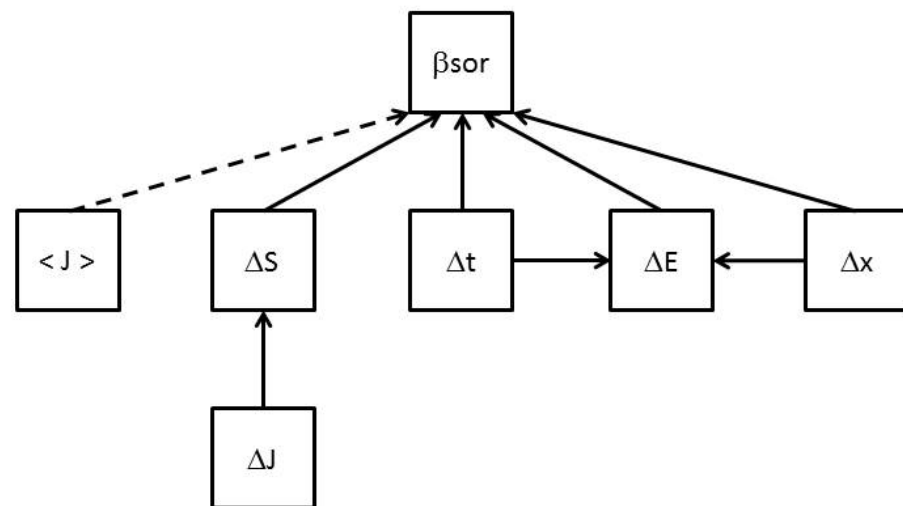

Methods

Assessing the path analysis framework with simulated data

We first devised an individual-based simulation algorithm of metacommunity dynamics in a discrete virtual landscape where communities are distributed across a two-dimensional grid. We simulated varying kinds of metacommunity dynamics in discrete time and analysed the simulated patterns to assess the performance of the proposed framework. We here first describe the simulation algorithm and then explain the simulated scenarios.

The metacommunity simulator

- Regional species pool

We consider a fixed regional species pool of S species ($S=100$), each species i having a fixed regional frequency χ_i and a fixed trait value τ_i . In the following, all species have the same regional frequency ($\chi_i = 0.01$) and trait values are regularly spaced between 0 and 1 ($\tau_i = i/100$).



- Landscape

We consider a gridded landscape of 400 cells (20 x 20) with fixed null boundary conditions. Abiotic environmental conditions within each cell k are assumed homogeneous within the cell and are measured with a single environmental variable $E_k(t)$ that can vary in time (t). This environmental variable will influence the processes of adult mortality and propagule establishment in each cell. There are $J_k(t)$ individuals per cell, this number varying across space and time, depending on the balance between recruitment/immigration and mortality in each cell.

- Environmental dynamics

The environmental variable $E_k(t)$ in cell k at time t is decomposed into three components:

$$E_k(t) = g_k + a_t + a_k(t) \quad (\text{Eq. 1})$$

where g_k represents an average environmental context in cell k , a_t represents a temporal trend common to all cells, and $a_k(t)$ represents a cell-specific temporal anomaly.

More specifically, we consider in the following a linear environmental gradient from the left to the right of the two-dimensional grid, so that g_k regularly varies from $0.5 - e_1/2$ to $0.5 + e_1/2$ according to the column of the cell, g_k being constant on each column; a_t is uniformly drawn between $-e_2/2$ and $e_2/2$ at each time step t ; $a_k(t)$ is uniformly drawn between $-e_3/2$ and $e_3/2$ at each time step t and for each cell k .

Environmental dynamics are parameterized with the three parameters e_1 , e_2 and e_3 controlling the magnitude of the spatial environmental gradient, of the spatially synchronous temporal environmental variability and of the spatially asynchronous temporal environmental variability, respectively. Note that with these modelling choices, we are able to simulate a spatial environmental gradient, but we do not consider a directional temporal trend in environmental conditions. Besides, we control the magnitude of temporal variations, but we do not control their autocorrelation (equal to zero in all simulations). Valuable information on the temporal autocorrelation of both a_t and $a_k(t)$ could also be extracted from temporal diversity patterns and in turn inform about ecological processes (Jabot & Lohier 2016), but here we will instead focus on the magnitude of these variables.

- Community dynamics

In each cell and during each time step, the dynamics of the community is governed by four processes taking place sequentially: 1) reproduction, 2) propagule dispersal,



3) adult mortality and 4) propagule establishment. All cells are simultaneously updated.

1) *Reproduction*

Each individual of the community produces propagules at a constant rate r so that the number of propagules produced by each individual during one time step is a random draw from a Poisson distribution with parameter r (with $r \leq 1$).

2) *Dispersal*

A proportion $(1-m)$ of the propagules stays in their home cell, while a proportion m disperses in the eight neighbouring cells (uniform random draws). On top of this local dispersal, additional propagules arrive from the regional species pool (described above) at a constant rate l in each cell, so that the number of such long-distance dispersal propagules is computed as a Poisson draw with parameter l .

3) *Mortality*

Each individual of species i has a local fitness $f_i(k,t)$ in cell k at time t that depends on the match between its trait value τ_i and the environmental variable $E_k(t)$ in cell k at time t . More precisely, $f_i(k,t)$ is given by the equation:

$$f_i(k,t) = 1 + A \times \exp \left[- (\tau_i - E_k(t))^2 / (2\sigma^2) \right] \quad (\text{Eq. 2})$$

where parameter A controls the strength of environmental filtering (complete maladaptation leads to a local fitness of 1 while perfect adaptation to a local fitness of $1 + A$) and parameter σ controls its specificity (a relatively good local adaptation is obtained when $|\tau_i - E_k(t)|$ is less than σ).

The survival of adult individuals of species i is modelled at each time step t in cell k as a Bernoulli draw with probability $(1-r) \times f_i(k,t) / (1+A)$. This implies that each individual has a probability of dying that is at least equal to r , this death probability increasing as individual fitness decreases.

4) *Establishment*

We consider that each cell has a carrying capacity of J individuals. We therefore model the number of recruited individuals $N_r(k,t)$ in a cell k at time t as a random variable having a Poisson distribution with mean equal to $J - N_k(t)$, where $N_k(t)$ is the number of surviving adults in the cell after the mortality step. If $N_k(t)$ is already larger than J , then no individual is recruited. This modelling choice enables the number of individuals per cell to vary temporally. The $N_r(k,t)$ recruited individuals are chosen through a multinomial draw with species probabilities of being drawn proportional to their number of propagules that have reached the focal cell. This modelling does not therefore consider cases in which propagules would be in insufficient numbers to fill available recruitment opportunities.



- Initialization of the metacommunity, burn-in period and sampling

The metacommunity is initialized with a multinomial random draw of J individuals from the regional species pool in each cell. A burn-in period of 10,000 time steps is used, which was empirically found to be sufficient to reach a dynamical equilibrium of species richness (Fig. S5). Afterwards, metacommunity dynamics continues for 20 time steps and the local community composition of 50 randomly selected cells (out of the 400) is recorded at each time step for subsequent analyses. The C++ code of this metacommunity simulator is provided in Supplementary material S1.

Simulated scenarios

We devised 6 different scenarios representing archetypical assembly situations: two neutral scenarios, two scenarios with environmental filtering and no dispersal between neighbouring cells, and two scenarios with both environmental filtering and dispersal (Table 1). Our aim was 1) to qualitatively assess whether our heuristic predictions were confirmed in archetypical situations and 2) to examine situations in which temporal data on metacommunity dynamics bring additional insights on assembly processes compared to analyses solely based on snapshot data.

More precisely, the first scenario represents a case of neutral assembly without dispersal between neighbouring cells very similar to Hubbell's metacommunity model (Hubbell 2001). The second scenario represents a case of neutral assembly with dispersal between neighbouring cells similar to models such as Gascuel et al.'s (2016). The third scenario represents a case of strong environmental filtering in a temporally constant environmental gradient and without dispersal between neighbouring cells. The fourth scenario represents a case of strong environmental filtering in spatially homogeneous but temporally varying environmental conditions and without dispersal between neighbouring cells. The fifth scenario represents a case of strong environmental filtering with both a constant environmental gradient and spatially homogeneous temporal environmental variations, and with dispersal between neighbouring cells. The sixth scenario represents a case of strong environmental filtering with no spatial environmental gradient but with environmental conditions that are temporally varying in a spatially inhomogeneous way, and with dispersal between neighbouring cells. Detailed parameter settings and some descriptive statistics of the different scenarios are given in Appendix S2. These parameter settings were manually determined by trials and errors so that average local community size was about 500 and average local richness in the cells was about 20 in all scenarios.



Table 1. Ecological processes and environmental spatiotemporal variations included in the six simulated scenarios

| Scenario | Ecological processes | | | | Environmental variables | | |
|----------|----------------------|---|---|----------|-------------------------|----------------|----------------|
| | l | m | A | σ | e ₁ | e ₂ | e ₃ |
| 1 | + | - | - | - | - | - | + |
| 2 | + | + | - | - | - | - | + |
| 3 | + | - | + | + | + | - | - |
| 4 | + | - | + | + | - | + | - |
| 5 | + | + | + | + | + | + | - |
| 6 | + | + | + | + | - | + | + |

Path analyses

We computed Sorensen community dissimilarity indices for all pairs of sampled communities. In this way, pairs of communities sampled at the same date report purely spatial dissimilarity, pairs of communities sampled at the same site but at different dates report purely temporal dissimilarity and the remaining pairs of communities report spatio-temporal dissimilarity. Similarly, we computed spatial distances (Δx), temporal distances (Δt) and environmental distances (ΔE) for each pair of communities, as well as their mean community size ($\langle J \rangle$), their absolute difference in community size (ΔJ) and in species richness (ΔS). We ran a path analysis on such datasets based on the heuristic causal model (Fig. 2) with the function “sem” of the R package “lavaan” (Rosseel 2012) and reporting standardized path coefficients. Since path analyses were based on distance matrices, we used the permutation-based approach developed by Fourtune et al. (2018) that takes into account the non-independence of the data points and that allows to confidently test for the significance of each path. We followed a Benjamini-Hochberg procedure to adjust the significance criterion (of 1%) for multiple testing. We assessed model fit with the Standardized Root Mean Square Residual (SRMR) that is a standard measure of model fit for path analyses.

Empirical datasets

A-Freshwater fishes

We tested the applicability of our conceptual framework on four case studies. The first case study is based on the AFB (“Agence Française pour la Biodiversité”, i.e. the French Agency for Biodiversity) database synthesizing freshwater fish communities from yearly samples in more than 1500 sites in France (Poulet et al. 2011). Here, we restrain our analysis to a subset synthesizing temporal data from the Garonne-Dordogne river drainage in South-Western France (see Fourtune et al. 2016 for details). This sub-dataset included 32 sites that were thoroughly monitored each year between 1995 and 2011 and for which precise environmental variables were available. This dataset included 51 fish species, for a total of 257,393 sampled fishes.



Six environmental variables were recorded for each site: elevation, slope, average temperature in January 2011, average temperature in July 2011, width of the minor bed, and width of the water slide. The first five variables were temporally constant, while the last variable varied from year to year. Geographical distance between sites was computed along the river using the Carthage dataset of the IGN (French National Geographical Institute). We used log-transformed distances in the analyses reported here, but results were qualitatively similar when using raw distances.

B-Aquatic invertebrates

The second dataset compiles aquatic invertebrate communities across the Rhône river drainage in France. Benthic invertebrates were sampled on 6 sites of 11 different watersheds for a total of 66 sites. They were sampled for six months consecutively from the end of autumn to the beginning of summer for two years, 2014 and 2015, for a total of 12 sampling dates. The rivers considered are intermittent and as such, subject to temporary cessation of flow and/or absence of surface water; when some sites were dry, they were not sampled at this date. Invertebrates were identified to the genus level but information was kept at the family level when no taxa were identified at the genus level for this family, resulting in a total of 231 taxa. Five environmental variables were measured for each site at each sampling date: temperature, pH, conductivity, concentration in dioxygen and number of days since the last rewetting event of the watershed. Log-transformed Euclidean distances between sites were used as a proxy of spatial effect.

C-Freshwater snails

The third dataset concerns the malacological fauna – 27 species - of a freshwater ponds network in the Guadeloupe Island (Lesser Antilles). 250 sites are yearly sampled since 2001 (17 years), where species densities are recorded. Species densities were multiplied by pond area to obtain estimated species abundances in each pond that were subsequently log-transformed. Each site is characterized by six temporally constant environmental variables (size, depth, vegetation cover, water quality, litter and a synthetic index of hydrological and vegetation stability, see Lamy et al. (2013) for additional details), and one temporally varying but spatially constant variable (annual rainfall). Geographical distances among sites were computed as Euclidean distances and were log-transformed. Missing data and empty sites were removed prior to analyses leading to a total of *ca.* 2800 samples.

D-Aquatic plants

The fourth dataset compiles aquatic plant communities in shallow lakes used for fish farming. These lakes are in general dried out during one year every 3 years. Twenty-four shallow lakes were sampled from 2 to 7 years between 2008 and 2015, for a



total of 81 sampling events and 84 sampled plant species (Arthaud et al. 2013). Average species cover was multiplied by lake areas to obtain estimated species abundances in each lake. Two environmental variables were used: chlorophyll a concentration that corresponds to water turbidity and light transmission, and the number of years since the last drying event.

Results

Analysis of simulated data

The path analysis on simulated data confirmed our heuristic predictions regarding the paths produced by each ecological process. In the two neutral scenarios, a positive correlation between geographical distance and spatiotemporal community dissimilarity was found (Fig. 3a,b). For the first scenario without local dispersal (Fig. 3a), this correlation was modest and was solely due to smaller values of dissimilarity across time within a patch, compared to values of dissimilarity among distinct communities, but without any effect of distance past this distinction (Fig. S5). The correlation was larger in the second scenario with local dispersal since distance is expected to affect the degree of overlap of local communities (Fig. 3b). Under the species-sorting scenarios without local dispersal among patches, environmental filtering was found to produce a positive correlation between environmental distance and community dissimilarity (Fig. 3c,d), as well as a positive correlation between geographical distance and environmental distance in the spatially structured environmental scenario (Fig. 3c). When all processes were simultaneously at play, the path analysis successfully detected all the predicted paths (Fig. 3e). Finally, in the last temporally varying environmental scenario without spatial structure, the path analysis successfully detected the effect of environmental distance and temporal distance on community dissimilarity (Fig. 3f). Some scenarios also led to positive correlations between the difference in community size and the difference in local species richness and between the difference in local species richness and community dissimilarity, as initially predicted (Fig. 3a-e). Note that no simulated scenario enabled us to evidence a direct link between mean community size and community dissimilarity, since communities did not much vary in size in the simulations (by construction). In summary, our application of a causal modelling framework to simulated data enabled us to validate our heuristic predictions and to show that the modelling framework allows reliable inference of the ecological processes driving spatiotemporal variation in community composition, for contrasted simulation scenarios.

Figure 3. Path analyses on the six simulated scenarios



Arrows depict significant effects. Arrow width represents the strength of the standardized estimates. Numerical values are reported in Table S3. The average community size ($\langle J \rangle$) was omitted from these figures since it never had a significant effect in the simulations that harboured almost constant community sizes in the landscape.

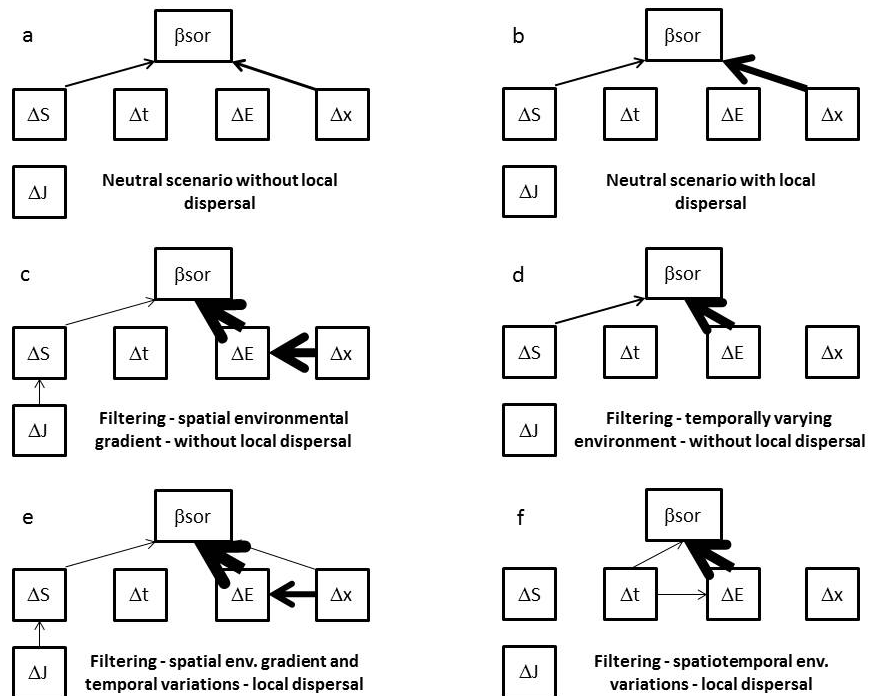

Analysis of empirical datasets

Applied to the four datasets, our statistical framework revealed very consistent patterns across case studies (Fig. 4). The influence of demographic stochasticity was evidenced in all case studies (see the dashed lines from $\langle J \rangle$ to β_{sor}). Geographic distances Δx were found to affect community dissimilarity (β_{sor}) in all case studies, both directly (putatively through dispersal limitation) and indirectly through environmental distances ΔE . Environmental distances ΔE were found to influence community dissimilarity (β_{sor}) in all case studies. Temporal distances Δt were found to impinge on environmental distances in three of the four case studies and directly affect community dissimilarity in half of the case studies. Finally, differences in local species richness ΔS were found to affect community dissimilarity in all case studies, with differences in local community sizes ΔJ influencing ΔS in three of the four case studies. This last result confirms the importance of taking this variable ΔS into account when assessing the drivers of community dissimilarity.



Although we found support for the three main types of ecological drivers (demographic stochasticity, environmental variation and dispersal limitation), environmental variation was generally the strongest driver of community dissimilarity. This environmental variation was both spatially and temporally structured in three of the four case studies (see the arrows from Δx and Δt towards ΔE). This further supports our call for an integrated spatiotemporal appraisal of metacommunity patterns.

Figure 4. Path analyses for the four empirical datasets

a: freshwater fishes. b: aquatic invertebrates. c: molluscs. d: aquatic plants. Arrow width represents the strength of the standardized estimates. Dashed lines represent negative relationships. Paths from and towards ΔE were pooled in single arrows by summing the absolute values of the significant paths associated to each environmental variable. Only significant paths are shown. Numerical values of the standardized coefficients and of the associated p-values are reported in Tables S11-14. Values of the Standardized Root Mean Square Residual (SRMR) are mentioned for each dataset. Fish by Vladimir Belochkin, shrimp by Ana María Lora Macias, snail by Vega Asensio and cattail by Alex Muravev from the Noun Project.

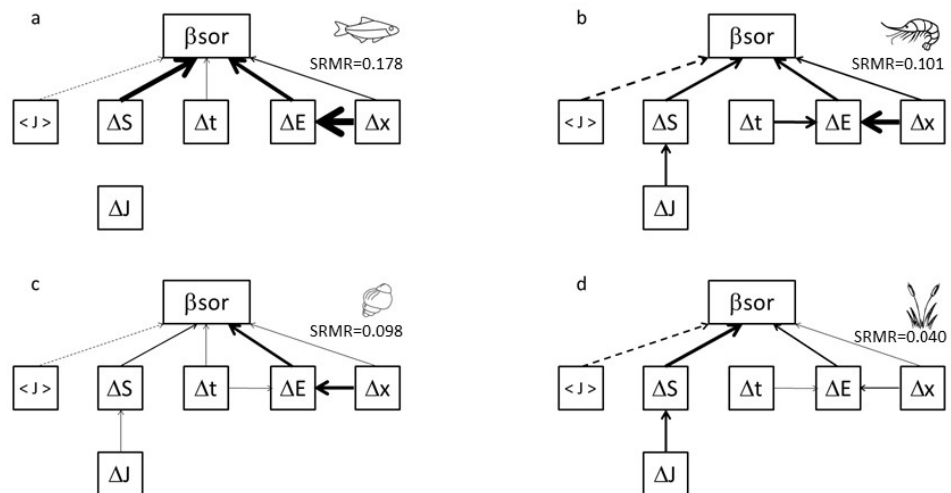

Discussion

The benefits of analysing spatiotemporal community turnover

Our analyses of simulated metacommunities demonstrate that the causal analysis of spatiotemporal turnover indices allows detecting the influences of dispersal, demographic stochasticity and environmental filtering on metacommunity dynamics



(Fig. 3). We are confident that the proposed framework is robust and general since we examined strongly contrasted simulated scenarios that all lead to path analysis results that were consistent with simulation choices. These analyses also point out that a spatiotemporal analysis is more powerful than purely spatial or purely temporal analyses for detecting the effect of environmental filtering, especially for spatially heterogeneous and temporally varying environmental conditions (Fig. 3e,f). In such conditions, knowing both the previous and current compositional states of the local community is indeed likely to be key to understand its driving forces, hence the power of analysing temporal turnover rather than solely spatial turnover. Still, even in such cases, the spatial structure in terms of mean environmental conditions is likely to contain valuable signal indicative of metacommunity processes (in particular dispersal limitation and environmental filtering), hence the larger power of a spatiotemporal analysis compared to a purely temporal one.

Detecting the contributions of entangled ecological processes

In the proposed causal modelling framework, the relative strengths of the paths can be interpreted as reflecting the respective impacts of the underlying ecological processes on community turnover: the path from geographical distance (Δx) to β_{sor} represents the effect of dispersal on community turnover, the one from environmental distance (ΔE) encapsulates the effect of environmental filtering and the ones from mean community size ($\langle J \rangle$) and temporal distance (Δt) encapsulate the effect of demographic stochasticity (ecological drift). Indirect paths from Δx and Δt through ΔE encapsulate the spatiotemporal structure of environmental variability, that is, whether environmental variation is mainly spatial or temporal. Finally, differences in community size (ΔJ) can affect differences in species richness (ΔS) through the so-called more-individuals hypothesis (Srivastava & Lawton 1998; Storch et al. 2018), and this may in turn affect community turnover (Fig. 2). Specific hypotheses on the drivers of these differences could be easily included in this framework, by adding other paths and driving variables to represent these hypotheses.

Applied to the fish metacommunity data, this spatiotemporal framework revealed that the turnover in fish community composition at yearly and regional scales is mainly driven by environmental filtering, although demographic stochasticity and dispersal do contribute to community turnover (Fig. 4a). Another main driver of community turnover is the heterogeneity in richness among local communities (ΔS), which we interpret as a nuisance variable here, since we do not have specific hypotheses on what may drive this heterogeneity beyond differences in community size (ΔJ). Alternative – yet non-exclusive – explanations for the observed variability in local species richness include the presence of a natural upstream-downstream



gradient in species richness with more species near the outlet of the river networks (Muneepeerakul et al. 2008, Blanchet et al. 2014) and the introduction of non-native species that may not be homogeneous across the river network. Our analysis reveals that such potential drivers may have a dominant impact on the overall fish metacommunity structure at the regional scale.

Applied to the invertebrate metacommunity data, the main driver of community turnover was also the heterogeneity in richness among local communities (Fig. 4b). This may result from the fact that this dataset comprises perennial and intermittent sites, and the latter ones generally harbour species-poor, original communities with taxa especially adapted to recover from disturbances (Datry et al. 2014). The other main drivers were demographic stochasticity and dispersal which may be explained by the intensity of local disturbances and regional disconnections caused by drying events. Temporal and spatial distances also have a strong effect on environmental distances as expected for intermittent rivers, as the stochasticity of drying events leads to a high spatiotemporal variability of the environment.

For the last two datasets, environmental variation was found to be the main driver of community dissimilarity. This environmental variation was found to be both spatially and temporally structured. This highlights the fact that environmental filtering is both varying across space and time. This further supports our call for an integrated spatiotemporal approach to analyse metacommunity patterns and to better decipher the ecological drivers that shape metacommunity dynamics.

More generally, we found very consistent results among the four case studies despite the variety of sampled taxonomic groups (plants, aquatic invertebrates, molluscs and fishes) and habitats (lakes, ponds, perennial streams and intermittent rivers). This may indicate the generality of the significance of the spatiotemporal variation of environmental conditions for metacommunity dynamics. Ecologists should therefore urgently embrace a more dynamical view of metacommunity assembly and look beyond the predominant perspective which considers communities as assembled through temporally fixed environmental filters. This present contribution offers a pragmatic way forward in this direction.

Applying the proposed framework to metacommunity data

The proposed framework requires temporal data of metacommunity composition and temporal environmental variables that are thought to be influential for the system studied. Since the approach is exploratory, it does not require a minimal amount of sampled dates nor of sampled locations (beyond 2) to be operational. In the studied datasets, the number of sampled dates varied from 2 to 17, while the



number of sampled locations varied from 24 to 250. Our approach relies on the analysis of community dissimilarity indices, so that it can be applied to species-rich communities that contain a substantial amount of rare species with low occurrence frequencies. The proposed approach is easy to conduct, since it does not require any advanced statistical training. It allows performing a first exploratory analysis of empirical data to assess the respective influences of complementary drivers of metacommunity dynamics (see Kingsolver & Schemske 1991 and Shipley 2000 for related discussions).

As explained in Box 1, some ecological systems may deviate from our general predictions for a variety of reasons. For such systems, users should consider building alternative heuristic path models that may be biologically more relevant. Such alternative path models may assume a different set of paths between the variables depicted in Fig. 2, or they may assume opposite signs for the predicted relationships, or they may even make use of alternative variables in the analysis. For instance, environmental variables may display cyclic temporal dynamics. In such cases, it may be more pertinent to consider phase difference rather than absolute time difference (Δt). Another example is the one of disease or population outbreaks that travel through space and sometimes constitute a genuine environmental perturbation for entire communities (e.g., a polyphagous moth defoliator for tree communities, Tenow et al. 2013). In this case again, absolute time may not be a pertinent variable and may be fruitfully replaced by the state of outbreak ($x-vt$) where v is the speed of the travelling wave and x is the position of the site considered. Our proposition is a simple and versatile approach to analyse standardized path coefficients, although this may not always be the choice to be favoured (Grace & Bollen 2005), so that researchers should evaluate the pros and cons of this choice for their particular case study.

Although the proposed framework appears powerful and robust, it is important to keep in mind that only simple linear relationships are modelled in the path analysis. Our analysis of simulated datasets supports this simple assumption (Fig. S5-10) and variable transformation procedures can be used to correct obvious non-linearities, as done here for some empirical case studies using log-transformation of geographical distances. Still, results should be solely interpreted as rough estimates of the respective influences of dispersal, demographic stochasticity and environmental filtering on community dynamics. Explored path models are therefore not meant to be predictive. For such an endeavour, process-based dynamical models of metacommunity dynamics may be a much more suited way forward.

Linking the proposed framework to process-based dynamical models



To go beyond the exploratory analysis enabled by the present approach, more detailed inferences need to be grounded on more mechanistic modelling tailored to the particular case study (Evans et al. 2013, Mouquet et al. 2015). Such process-based dynamical models, however, require much more data on the system studied to be relevant. By enabling the identification of important drivers of metacommunity dynamics, the proposed framework can help design relevant process-based models that focus on the most influential processes.

Several types of process-based models can be distinguished in this respect. Ovaskainen et al. (2017) recently proposed to devise community models as hierarchical models of individual species dynamics. Such an approach is best suited for communities with a modest number of species that have sufficiently large occurrence frequencies to inform the model parameters. This approach is still to be extended to deal with temporal abundance data (Ovaskainen et al. 2017). Other even more demanding approaches rely on detailed individual-based models of metacommunity dynamics that can be compared to field data thanks to computer-intensive statistical techniques such as approximate Bayesian computation (ABC, Beaumont 2010, Jabot et al. 2013, Overcast et al. 2019). Although several metacommunity simulators have been developed and distributed (e.g., Münkemüller & Gallien 2015, Keyel et al. 2016, Sokol et al. 2017, Munoz et al. 2018), tailoring a spatially explicit metacommunity simulator to a specific case study to perform a genuine model-based ABC inference from metacommunity time series is still a challenge ahead.

Data accessibility

Data are available online:

<http://doi.org/10.5281/zenodo.3381338> (freshwater fishes dataset).

<http://doi.org/10.5281/zenodo.3377490> (aquatic invertebrates dataset)

<http://doi.org/10.5281/zenodo.3379615> (molluscs dataset)

<http://doi.org/10.5281/zenodo.3383940> (aquatic plants dataset)

<http://doi.org/10.5281/zenodo.3381340> (simulated datasets)

Supplementary material

The C++ code to simulate the spatiotemporal dynamics of metacommunities is available at https://github.com/franckjabot/metacommunity_simulator; the R scripts to perform the path analysis of metacommunity spatio-temporal data and a tutorial



for data formatting are available at <https://github.com/franckjabot/metacommunity-analysis-script>

Acknowledgements

This preprint has been peer-reviewed and recommended by Peer Community In Ecology (<https://doi.org/10.24072/pci.ecology.100027>). We thank the reviewers for their constructive comments. This work has been funded by the Irstea-Carnot project “MetaRISC”. This research was financed by the French government IDEX-ISITE initiative 16-IDEX-0001 (CAP 20-25). It has been partly undertaken at SETE, a laboratory which is part of the “Laboratoire d’Excellence” (LABEX) entitled TULIP (ANR-10-LABX-41). FM is funded by the CNRS and the ANR-funded ARSENIC and NGB projects (grants no. ANR-14-CE02-0012 and ANR-17-CE32-0011).

Conflict of interest disclosure

The authors of this preprint declare that they have no financial conflict of interest with the content of this article. FJ, FL, FM, SB, FM and TD are recommenders for PCI Ecology

References

- Acuña, V., Datry, T., Marshall, J., Barceló, D., Dahm, C.N., Ginebreda, A. *et al.* (2014). Why should we care about temporary waterways? *Science*, 343, 1080-1081.
- Anderson, M.J. & Cribble, N.A. (1998). Partitioning the variation among spatial, temporal and environmental components in a multivariate data set. *Austr. Ecol.*, 23, 158-167.
- Amarasekare, P. & Nisbet, R.M. (2001). Spatial heterogeneity, source-sink dynamics, and the local coexistence of competing species. *Am. Nat.*, 158, 572-584.
- Arthaud, F., Vallod, D., Wezel, W., Robin, J. & Bornette, G. (2013). Short-term succession of aquatic plant species richness along ecosystem productivity and dispersal gradients in shallow lakes. *J. Veg. Sci.*, 24, 148-156.
- Azaele, S., Pigolotti, S., Banavar, J.R. & Maritan, A. (2006). Dynamical evolution of ecosystems. *Nature*, 444, 926-928.
- Baselga, A. (2010). Partitioning the turnover and nestedness components of beta diversity. *Global Ecology and Biogeography*, 19, 134-143.
- Beaumont, M.A. (2010). Approximate Bayesian computation in evolution and ecology. *Annu. Rev. Ecol. Evol. Sys.*, 41, 379-406.
- Bertrand, C., Burel, F. & Baudry, J. (2016). Spatial and temporal heterogeneity of the crop mosaic influences carabid beetles in agricultural landscapes. *Land. Ecol.*, 31, 451-466.



- Blanchet, S., Helmus, M.R., Brosse, S. & Grenouillet, G. (2014). Regional vs local drivers of phylogenetic and species diversity in stream fish communities. *Fresh. Biol.*, 59, 450-462.
- Borcard, D., Legendre, P. & Drapeau, P. (1992). Partialling out the spatial component of ecological variation. *Ecology*, 73, 1045-1055.
- Brokaw, N.V. (1985). Gap-phase regeneration in a tropical forest. *Ecology*, 66, 682-687.
- Brown, B.L., Sokol, E.R., Skelton, J. & Tornwall, B. (2017). Making sense of metacommunities: dispelling the mythology of a metacommunity typology. *Oecologia*, 183, 643-652.
- Buckley, H.L., Day, N.J., Case, B.S., Lear, G. & Ellison, A.M. (2018). Multivariate methods for testing hypotheses of temporal community dynamics. *bioRxiv*, 362822.
- Calcagno, V., Mouquet, N., Jarne, P. & David, P. (2006). Coexistence in a metacommunity: the competition-colonization trade-off is not dead. *Ecol. Lett.*, 9, 897-907.
- Chase, J.M. & Leibold, M.A. (2003). *Ecological Niches: Linking Classical and Contemporary Approaches*. University of Chicago Press, Chicago, Ill.
- Chave, J., & Leigh Jr, E. G. (2002). A spatially explicit neutral model of β -diversity in tropical forests. *Theor. Popul. Biol.*, 62, 153-168.
- Chesson, P. (2000). Mechanisms of maintenance of species diversity. *Annual review of Ecology and Systematics*, 31, 343-366.
- Cottenie, K. (2005). Integrating environmental and spatial processes in ecological community dynamics. *Ecol. Lett.*, 8, 1175-1182.
- Datry, T., Larned, S.T., Fritz, K.M., Bogan, M.T., Wood, P.J., Meyer, E.I. *et al.* (2014). Broad-scale patterns of invertebrate richness and community composition in temporary rivers: effects of flow intermittence. *Ecography*, 37, 94-104.
- Datry, T., Bonada, N. & Heino, J. (2016). Towards understanding the organisation of metacommunities in highly dynamic ecological systems. *Oikos*, 125, 149-159.
- Evans, M.R., Bithell, M., Cornell, S.J., Dall, S.R., Díaz, S., Emmott, S. *et al.* (2013). Predictive systems ecology. *Proc. R. Soc. B*, 280, 20131452.
- Fournier, B., Mouquet, N., Leibold, M.A. & Gravel, D. (2017). An integrative framework of coexistence mechanisms in competitive metacommunities. *Ecography*, 40, 630-641.
- Fourtune, L., Paz-Vinas, I., Loot, G., Prunier, J. G., & Blanchet, S. (2016). Lessons from the fish: a multi-species analysis reveals common processes underlying similar species-genetic diversity correlations. *Freshwater Biology*, 61, 1830-1845.
- Fourtune, L., Prunier, J. G., Paz-Vinas, I., Loot, G., Veyssi re, C., & Blanchet, S. (2018). Inferring causalities in landscape genetics: An extension of Wright's causal modeling to distance matrices. *The American Naturalist*, 191, 491-508.
- Gascuel, F., Laroche, F., Bonnet-Lebrun, A.-S. & Rodrigues, A.S.L. (2016). The effects of archipelago spatial structure on island diversity and endemism: predictions from a spatially-structured neutral model. *Evolution*, 70, 2657-2666.
- Gilbert, B. & Bennett, J.R. (2010). Partitioning variation in ecological communities: do the numbers add up? *J. App. Ecol.*, 47, 1071-1082.



- Grace, J. B., & Bollen, K. A. (2005). Interpreting the results from multiple regression and structural equation models. *The Bulletin of the Ecological Society of America*, 86, 283-295.
- Guichard, F. (2017). Recent advances in metacommunities and meta-ecosystem theories. *F1000Research*, 6, 610.
- Haegeman, B., Sari, T. & Etienne, R.S. (2013). Predicting coexistence of plants subject to a tolerance-competition trade-off. *J. Math. Biol.*, 68, 1815-1847.
- Hastings, A. (1980). Disturbance, coexistence, history, and competition for space. *Theor. Popul. Biol.*, 18, 363-373.
- Heino, J., Melo, A.S., Siqueira, T., Soininen, J., Valanko, S. & Bini, L.M. (2015). Metacommunity organisation, spatial extent and dispersal in aquatic systems: patterns, processes and prospects. *Fresh. Biol.*, 60, 845-869.
- Henriques-Silva, R., Lindo, Z. & Peres-Neto, P.R. (2013). A community of metacommunities: exploring patterns in species distributions across large geographical areas. *Ecology*, 94, 627-639.
- Hubbell, S.P. (2001). *The Unified Neutral Theory of Biodiversity and Biogeography*, Princeton University Press, Princeton, NJ.
- Jabot, F., Faure, T. & Dumoulin, N. (2013). EasyABC: performing efficient approximate Bayesian computation sampling schemes using R. *Meth. Ecol. Evol.*, 4, 684-687.
- Jabot, F. & Lohier, T. (2016). Non-random correlation of species dynamics in tropical tree communities. *Oikos*, 125, 1733-1742.
- Janzen, D. H. (1970). Herbivores and the number of tree species in tropical forests. *Am. Nat.*, 104, 501-528.
- Kalyuzhny, M., Kadmon, R. & Shnerb, N.M. (2015). A neutral theory with environmental stochasticity explains static and dynamic properties of ecological communities. *Ecol. Lett.*, 18, 572-580.
- Keyel, A.C., Gerstenlauer, J.L. & Wiegand, K. (2016). SpatialDemography: a spatially explicit, stage-structured, metacommunity model. *Ecography*, 39, 1129-1137.
- Kingsolver, J. G. & Schemske, D. W. (1991). Path analyses of selection. *Trends Ecol. Evol.*, 6, 276-280.
- Lamy, T., Jarne, P., Laroche, F., Pointier, J. P., Huth, G., Segard, A. *et al.* (2013). Variation in habitat connectivity generates positive correlations between species and genetic diversity in a metacommunity. *Mol. Ecol.*, 22, 4445-4456.
- Leibold, M.A. & Mikkelsen, G.M. (2002). Coherence, species turnover, and boundary clumping: elements of meta-community structure. *Oikos*, 97, 237-250.
- Leibold, M.A., Holyoak, M., Mouquet, N., Amarasekare, P., Chase, J.M., Hoopes, M.F. *et al.* (2004). The metacommunity concept: a framework for multi-scale community ecology. *Ecol. Lett.*, 7, 601-613.
- Leigh, E. G., Wright, S. J., Herre, E. A., & Putz, F. E. (1993). The decline of tree diversity on newly isolated tropical islands: a test of a null hypothesis and some implications. *Evol. Ecol.* 7, 76-102.
- Logue, J.B., Mouquet, N., Peter, H., Hillebrand, H. & Metacommunity Working Group. (2011). Empirical approaches to metacommunities: a review and comparison with theory. *Trends Ecol. Evol.*, 26, 482-491.
- Loreau, M. & Holt, R.D. (2004). Spatial flows and the regulation of ecosystems. *Am. Nat.*, 163, 606-615.



- MacArthur, R.H. & Wilson, E.O. (1967). *The Theory of Island Biogeography*, Princeton University Press, Princeton, NJ.
- Magurran, A. E., & Henderson, P. A. (2003). Explaining the excess of rare species in natural species abundance distributions. *Nature*, 422, 714.
- Magurran, A. E., & Henderson, P. A. (2010). Temporal turnover and the maintenance of diversity in ecological assemblages. *Philosophical Transactions of the Royal Society B: Biological Sciences*, 365, 3611-3620.
- Malard, F., Uehlinger, U., Zah, R. & Tockner, K. (2006). Flood-pulse and riverscape dynamics in a braided glacial river. *Ecology*, 87, 704-716.
- Massol, F. & Petit, S. (2013). Interaction networks in agricultural landscape mosaics. *Adv. Ecol. Res.*, 49, 291-338.
- Massol, F., Gravel, D., Mouquet, N., Cadotte, M.W., Fukami, T. & Leibold, M.A. (2011). Linking community and ecosystem dynamics through spatial ecology. *Ecol. Lett.*, 14, 313-323.
- May, R. M. (1973). *Stability and complexity in model ecosystems* (Vol. 6). Princeton university press.
- Molofsky, J., Bever, J. D., & Antonovics, J. (2001). Coexistence under positive frequency dependence. *Proceedings of the Royal Society of London. Series B: Biological Sciences*, 268, 273-277.
- Mouquet, N. & Loreau, M. (2003). Community patterns in source-sink metacommunities. *Am. Nat.*, 162, 544-557.
- Mouquet, N., Lagadeuc, Y., Devictor, V., Doyen, L., Duputié, A., Eveillard, D. *et al.* (2015). Predictive ecology in a changing world. *J. App. Ecol.*, 52, 1293-1310.
- Muller-Landau, H.C. (2010). The tolerance-fecundity trade-off and the maintenance of diversity in seed size. *Proc. Natl Acad. Sci. USA*, 107, 4242-4247.
- Muneepeerakul, R., Bertuzzo, E., Lynch, H.J., Fagan, W.F., Rinaldo, A. & Rodriguez-Iturbe, I. (2008). Neutral metacommunity models predict fish diversity patterns in Mississippi–Missouri basin. *Nature*, 453, 220.
- Münkemüller, T. & Gallien, L. (2015). VirtualCom: a simulation model for eco-evolutionary community assembly and invasion. *Meth. Ecol. Evol.*, 6, 735-743.
- Munoz, F., Grenié, M., Denelle, P., Taudière, A., Laroche, F., Tucker, C. *et al.* (2018). ecolottery: Simulating and assessing community assembly with environmental filtering and neutral dynamics in R. *Meth. Ecol. Evol.*, 9, 693-703.
- Nuvoloni, F.M., Feres, R.J.F. & Gilbert, B. (2016). Species turnover through time: colonization and extinction dynamics across metacommunities. *Am. Nat.*, 187, 786-796.
- Overcast, I., Emerson, B.C. & Hickerson, M.J. (2019) An integrated model of population genetics and community ecology. *J. Biogeo.*, 46, 816-829.
- Peres-Neto, P.R. & Legendre, P. (2010). Estimating and controlling for spatial structure in the study of ecological communities. *Glob. Ecol. Biogeogr.*, 19, 174–184.
- Peres-Neto, P.R., Legendre, P., Dray, S. & Borcard, D. (2006). Variation partitioning of species data matrices: Estimation and comparison of fractions. *Ecology*, 87, 2614-2625.



- Poulet, N., Beaulaton, L. & Dembski, S. (2011). Time trends in fish populations in metropolitan France: insights from national monitoring data. *J. Fish Biol.*, 79, 1436-1452.
- Preston, F.W. (1962). The canonical distribution of commonness and rarity: Part I. *Ecology*, 43, 185-215.
- Rosseel, Y. (2012). Lavaan: An R package for structural equation modeling and more. Version 0.5–12 (BETA). *Journal of statistical software*, 48, 1-36.
- Shipley, B. (2000). A new inferential test for path models based on directed acyclic graphs. *Structural Equation Modeling*, 7, 206-218.
- Shmida, A. & Wilson, M.V. (1985). Biological determinants of species diversity. *J. Biogeogr.*, 12, 1-20.
- Shoemaker, L.G. & Melbourne, B.A. (2016). Linking metacommunity paradigms to spatial coexistence mechanisms. *Ecology*, 97, 2436-2446.
- Skellam, J.G. (1952). Studies in Statistical Ecology: I. Spatial Pattern. *Biometrika*, 39, 346-362.
- Sokol, E.R., Brown, B.L. & Barrett, J.E. (2017). A simulation-based approach to understand how metacommunity characteristics influence emergent biodiversity patterns. *Oikos*, 126, 723-737.
- Srivastava, D.S. & Lawton, J.H. (1998). Why More Productive Sites Have More Species: An Experimental Test of Theory Using Tree-Hole Communities. *Am. Nat.*, 152, 510-529.
- Storch, D., Bohdalková, E. & Okie, J. (2018). The more-individuals hypothesis revisited: the role of community abundance in species richness regulation and the productivity–diversity relationship. *Ecol. Lett.*, 21, 920-937.
- Tenow, O., Nilssen, A. C., Bylund, H., Pettersson, R., Battisti, A., Bohn, U., et al. (2013). Geometrid outbreak waves travel across Europe. *Journal of Animal Ecology*, 82, 84-95.
- Tilman, D. (1994). Competition and biodiversity in spatially structured habitats. *Ecology*, 75, 2-16.
- Tscharntke, T., Klein, A.M., Kruess, A., Steffan-Dewenter, I. & Thies, C. (2005). Landscape perspectives on agricultural intensification and biodiversity–ecosystem service management. *Ecol. Lett.*, 8, 857-874.
- Ulrich, W., Kryszewski, W., Sewerniak, P., Puchałka, R., Strona, G. & Gotelli, N. J. (2017). A comprehensive framework for the study of species co-occurrences, nestedness and turnover. *Oikos*, 126, 1607-1616.
- Vannette, R. L., & Fukami, T. (2017). Dispersal enhances beta diversity in nectar microbes. *Ecol. Lett.*, 20, 901-910.



Appendices

Appendix S2: Additional information on the simulated scenarios.

We here provide some details on the simulated scenarios: the parameter sets used (Table S2), the numerical results of the path analyses (Table S3) and some descriptive patterns of the various scenarios (Fig. S5-S10). These supplementary figures depict for each of the six scenarios the response of community dissimilarity to the various simulated drivers: temporal distance, spatial distance and environmental distance.

Table S2. Model parameters used in the simulated scenarios

In addition, all simulations were performed with a value of r equal to 0.2.

| Scenario | l | m | A | σ | e_1 | e_2 | e_3 |
|----------|------|------|------|----------|-------|-------|-------|
| 1 | 1.4 | 0 | 0 | - | 0 | 0 | 1 |
| 2 | 0.1 | 0.03 | 0 | - | 0 | 0 | 1 |
| 3 | 80 | 0 | 10 | 0.05 | 0.2 | 0 | 0 |
| 4 | 5000 | 0 | 1000 | 0.01 | 0 | 0.1 | 0 |
| 5 | 500 | 0.5 | 1000 | 0.04 | 0.1 | 0.1 | 0 |
| 6 | 10 | 0.1 | 1000 | 0.06 | 0 | 0.3 | 0.1 |



Table S3. Standardized estimates and p-values for the path analyses on simulated scenarios (Fig.4)

p-values equal to 0 actually mean <0.001. Significant effects at the 1% level with a Benjamini-Hochberg correction are depicted in bold. The last line reports the Standardized Root Mean Square Residual (SRMR) that is a standard measure of model fit for path analyses.

| Scenario | 1 | 2 | 3 | 4 | 5 | 6 |
|--|------------------|-----------------------|-------------------------------|------------------|-----------------|-----------------------|
| $\beta_{sor} \leftarrow \langle J \rangle$ | -0.003 – 0.39 | 0.006 – 0.35 | 2.10^{-4} – 0.50 | -0.02 – 0.23 | -0.01 – 0.28 | -0.01 – 0.25 |
| $\beta_{sor} \leftarrow \Delta S$ | 0.12 – 0 | 0.17 – 0 | 0.03 – 0.002 | 0.17 – 0 | 0.05 – 0 | 0.01 – 0.11 |
| $\beta_{sor} \leftarrow \Delta t$ | 0.002 – 0.35 | 4.10^{-4} – 0.49 | -0.003 – 0.36 | 0.01 – 0.05 | 0.006 – 0.22 | 0.04 – 0 |
| $\beta_{sor} \leftarrow \Delta E$ | -0.001 – 0.35 | -0.002 – 0.38 | 0.86 – 0 | 0.65 – 0 | 0.87 – 0 | 0.73 – 0 |
| $\beta_{sor} \leftarrow \Delta x$ | 0.20 – 0 | 0.54 – 0 | 0.01 – 0.11 | 0.003 – 0.33 | 0.07 – 0 | 0.01 – 0.05 |
| $\Delta S \leftarrow \Delta J$ | 0.005 – 0.47 | 0.005 – 0.42 | 0.08 – 0 | 0.008 – 0.29 | 0.04 – 0.01 | 0.07 – 0 |
| $\Delta E \leftarrow \Delta t$ | -0.002 – 0.37 | -0.002 – 0.38 | 3.10^{-5} – 0.50 | -0.01 – 0.05 | -0.02 – 0.01 | 0.06 – 0 |
| $\Delta E \leftarrow \Delta x$ | -0.003 – 0.27 | 0.009 – 0.13 | 0.71 – 0 | -0.003 – 0.36 | 0.43 – 0 | 2.10^{-4} – 0.49 |
| SRMR | 0.009 | 0.019 | 0.009 | 0.023 | 0.021 | 0.042 |



Fig. S4. Mean local species richness during the burn-in period in the six simulated scenarios

Note that there is no directional trend that would indicate that the transient dynamics from the initial conditions are not terminated. Note also that in the second scenario (b), the temporal dynamics is slower, but without trend.

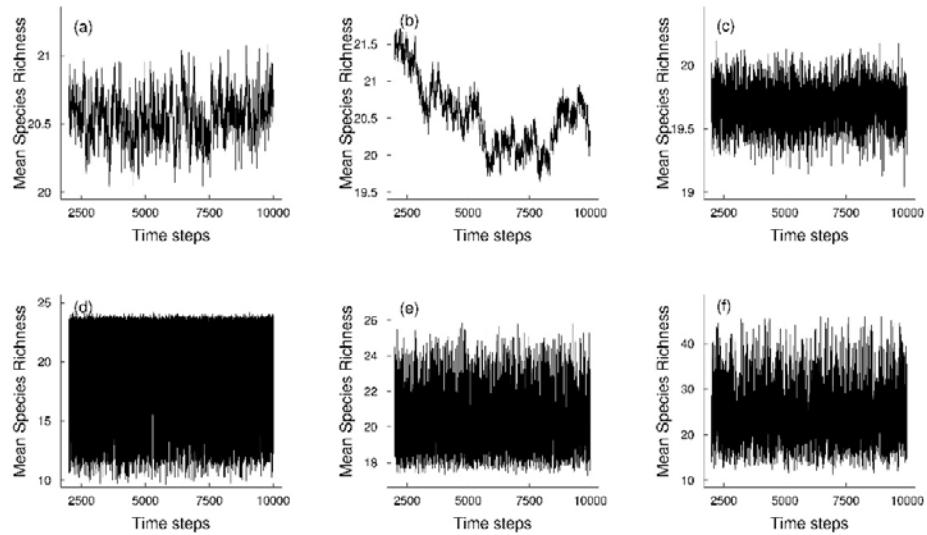



Fig. S5. Descriptive plots for the first scenario

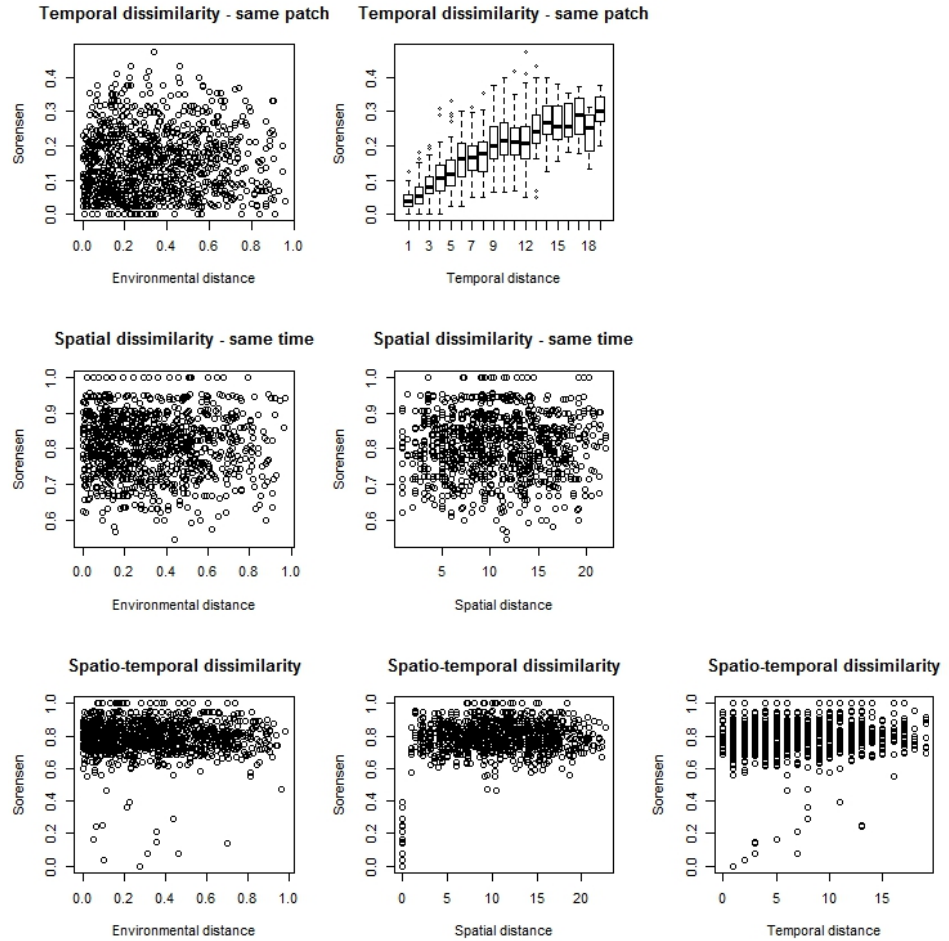



Fig. S6. Descriptive plots for the second scenario

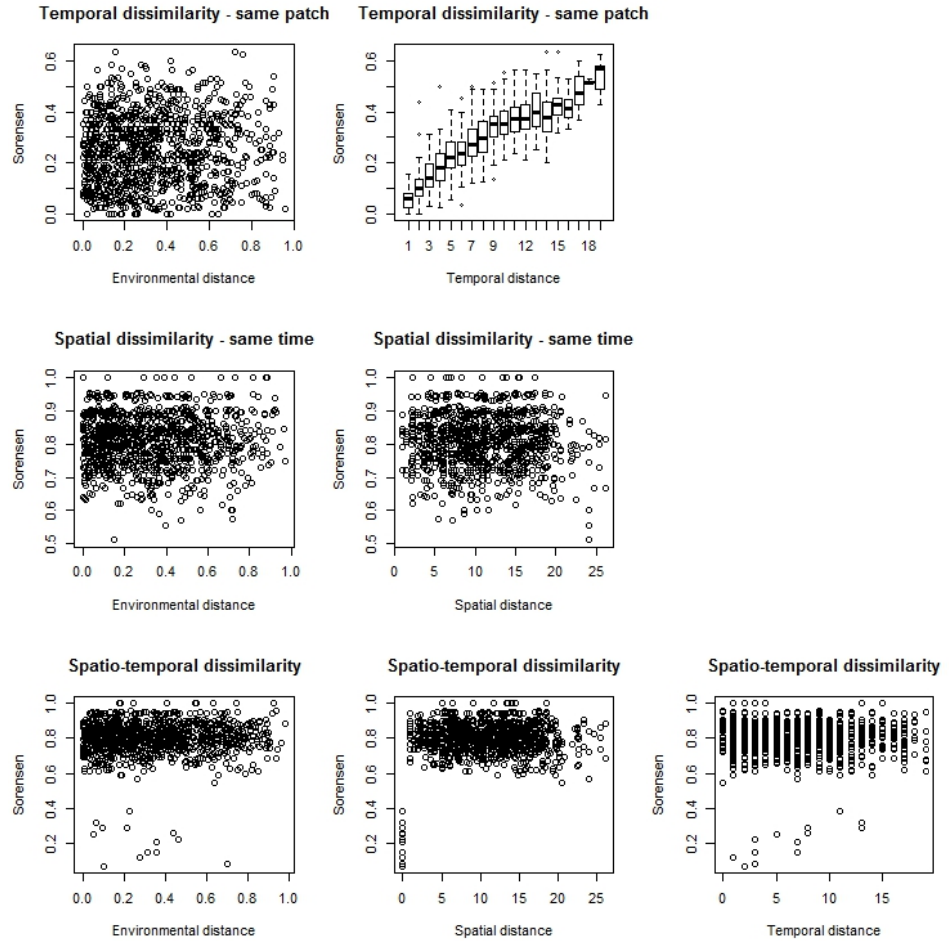



Fig. S7. Descriptive plots for the third scenario

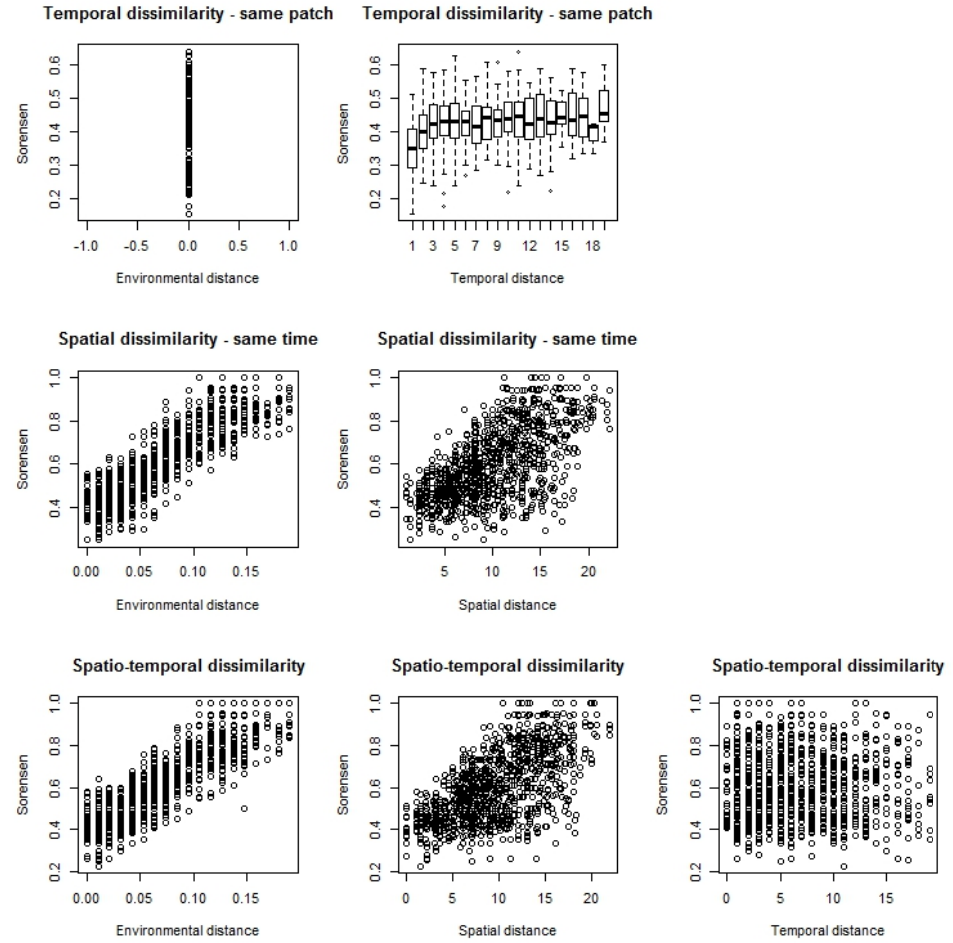



Fig. S8. Descriptive plots for the fourth scenario

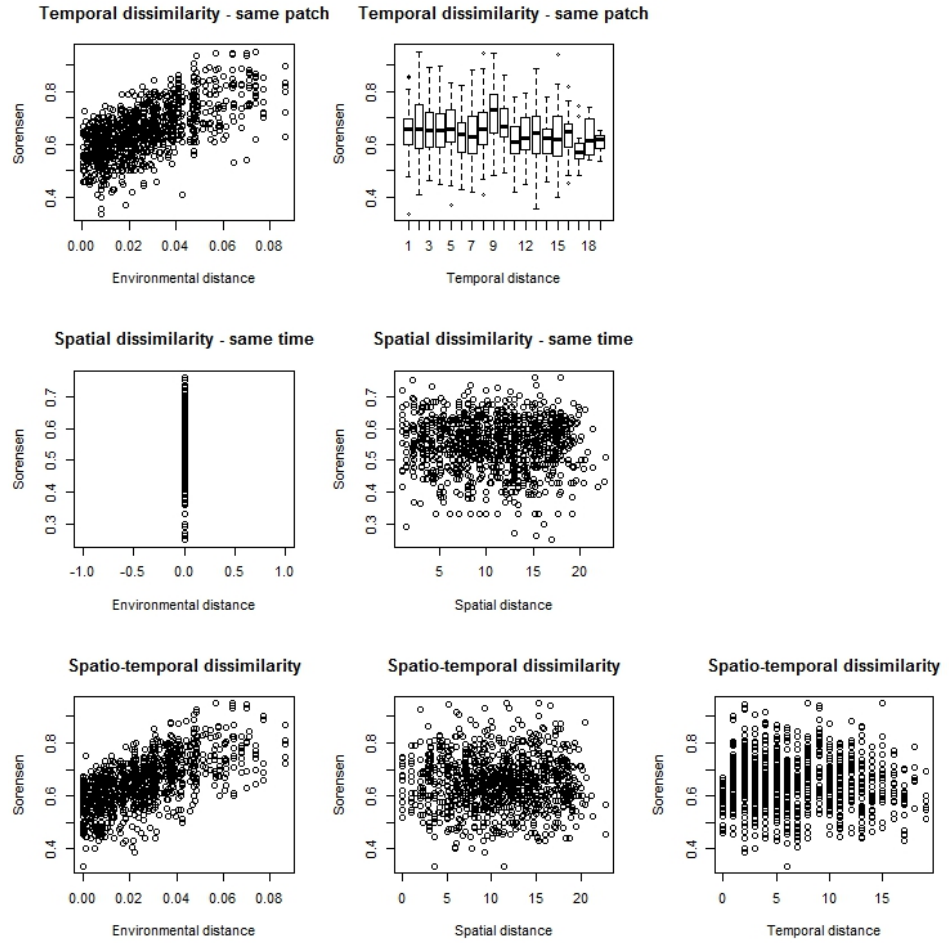



Fig. S9. Descriptive plots for the fifth scenario

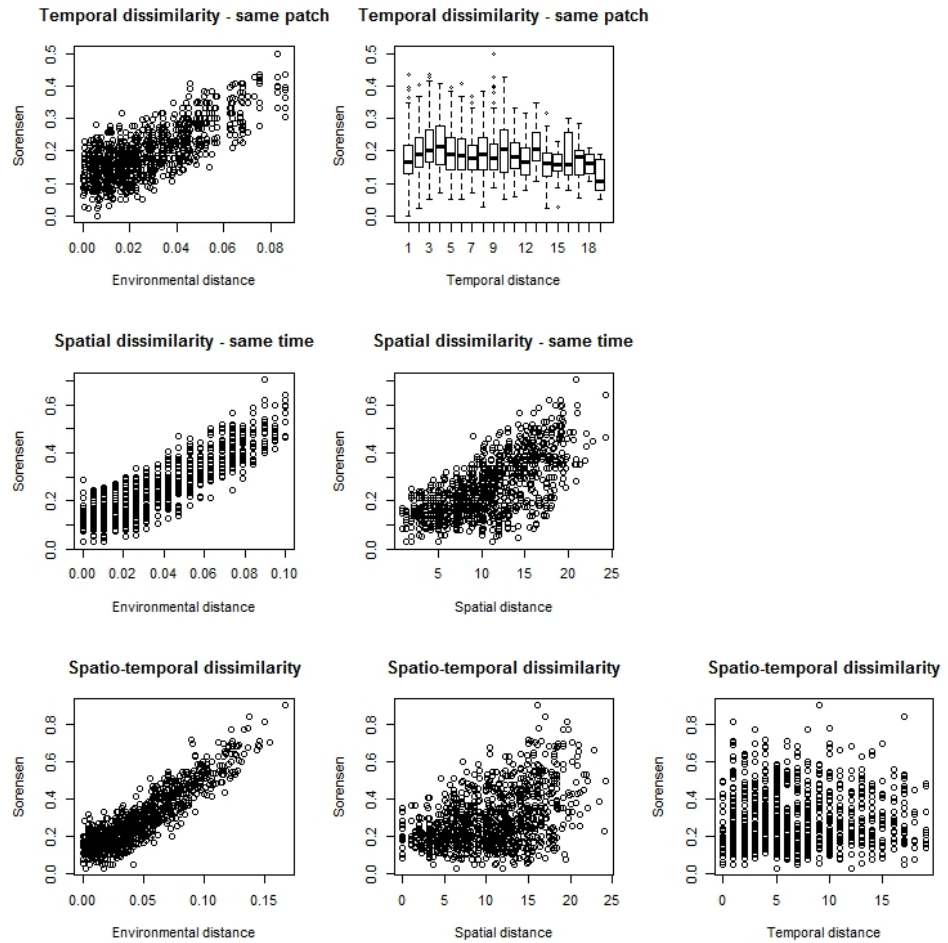
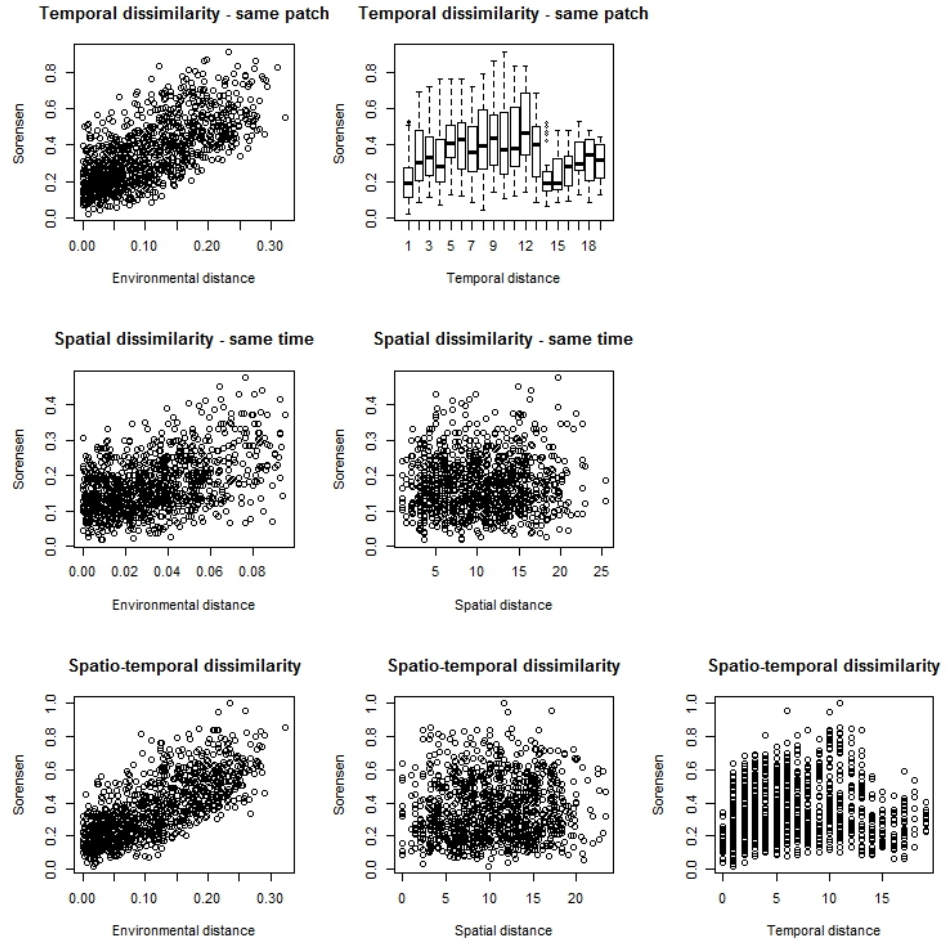



Fig. S10. Descriptive plots for the sixth scenario





Appendix S3: Additional information on empirical analyses.

We here provide the numerical results of the path analyses conducted for the four datasets (Tables S5-8).

Table S11. Standardized estimates and p-values for the path analysis of the AFB freshwater fish dataset

p-values equal to 0 actually mean <0.001. Significant effects at the 5% level with a Benjamini-Hochberg correction are depicted in bold. SRMR = 0.178.

| Environmental variables | | Width of the water slide | Width of the minor bed | Elevation | Slope | Average temperature in January 2011 | Average temperature in July 2011 |
|---|---------------------------------|-------------------------------|---------------------------|---------------------------|------------------------------|-------------------------------------|----------------------------------|
| $\beta_{\text{sor}} \leftarrow \langle J \rangle$ | -0.06 - 0 | | | | | | |
| $\beta_{\text{sor}} \leftarrow \Delta S$ | 0.70 - 0 | | | | | | |
| $\beta_{\text{sor}} \leftarrow \Delta t$ | 0.02 - 0.01 | | | | | | |
| $\beta_{\text{sor}} \leftarrow \Delta E$ | | 0.04 - 0.006 | 0.08 - 0 | 0.19 - 0 | 0.13 - 0 | 0.04 - 0.004 | 0.03 - 0.02 |
| $\beta_{\text{sor}} \leftarrow \Delta x$ | 0.13 - 0 | | | | | | |
| $\Delta S \leftarrow \Delta J$ | 0.03 - 0.11 | | | | | | |
| $\Delta E \leftarrow \Delta t$ | | 0.007 - 0.32 | | | | | |
| $\Delta E \leftarrow \Delta x$ | | 0.06 - 0 | 0.07 - 0 | 0.25 - 0 | 0.17 - 0 | 0.26 - 0 | 0.12 - 0 |



Table S12. Standardized estimates and p-values for the path analysis of the Irstea aquatic invertebrate dataset

p-values equal to 0 actually mean <0.001. Significant effects at the 5% level with a Benjamini-Hochberg correction are depicted in bold.

| Environmental variables | | Temperature | pH | Conductivity | Concentration in dioxygen | Number of days since the last rewetting event of the watershed |
|---|------------------------|--------------------|-----------------|-----------------|---------------------------|--|
| $\beta_{\text{sor}} \leftarrow \langle J \rangle$ | - 0.31 -0 | | | | | |
| $\beta_{\text{sor}} \leftarrow \Delta S$ | 0.47 -0 | | | | | |
| $\beta_{\text{sor}} \leftarrow \Delta t$ | 0.01 - 0.17 | | | | | |
| $\beta_{\text{sor}} \leftarrow \Delta E$ | | 0.07 - 0 | 0.11 - 0 | 0.10 - 0 | -0.06 - 0 | 0.03 - 0.02 |
| $\beta_{\text{sor}} \leftarrow \Delta x$ | 0.25 -0 | | | | | |
| $\Delta S \leftarrow \Delta J$ | 0.28 -0 | | | | | |
| $\Delta E \leftarrow \Delta t$ | | 0.08 - 0 | 0.11 - 0 | 0.04 - 0 | 0.02 - 0.08 | 0.18 - 0 |
| $\Delta E \leftarrow \Delta x$ | | 0.02 - 0.01 | 0.27 - 0 | 0.31 - 0 | 0.04 - 0 | 0.02 - 0 |



Table S13. Standardized estimates and p-values for the path analysis of the mollusc dataset

p-values equal to 0 actually mean <0.001. Significant effects at the 5% level with a Benjamini-Hochberg correction are depicted in bold.

| Environmental variables | | Pond size | Vegetation cover | Litter amount | Pond depth | Water quality | Stability | Annual rainfall |
|--|------------------------|-------------------|------------------|--------------------------------|-------------------------------|---------------------------|---------------------------|------------------------------|
| $\beta_{sor} \leftarrow \langle J \rangle$ | - 0.10 -0 | | | | | | | |
| $\beta_{sor} \leftarrow \Delta S$ | 0.12 -0 | | | | | | | |
| $\beta_{sor} \leftarrow \Delta t$ | 0.08 -0 | | | | | | | |
| $\beta_{sor} \leftarrow \Delta E$ | | 0 - 0.28 | 0.15 -0 | -0.02 - 0.003 | 0.10 - 0 | 0.06 - 0 | 0.05 - 0 | 0.02 - 0.02 |
| $\beta_{sor} \leftarrow \Delta x$ | 0.06 -0 | | | | | | | |
| $\Delta S \leftarrow \Delta J$ | 0.06 -0 | | | | | | | |
| $\Delta E \leftarrow \Delta t$ | | | | | | | | 0.07 - 0 |
| $\Delta E \leftarrow \Delta x$ | | 0.07 -0 | 0.01 - 0.11 | 0.13 -0 | 0.02 - 0.006 | 0.07 - 0 | 0.15 - 0 | |



Table S14. Standardized estimates and p-values for the path analysis of the aquatic plant dataset

p-values equal to 0 actually mean <0.001. Significant effects at the 5% level with a Benjamini-Hochberg correction are depicted in bold.

| Environmental variables | | Chlorophyll a concentration | Number of years since the last drying event |
|---|--------------------|-----------------------------|---|
| $\beta_{\text{sor}} \leftarrow \langle J \rangle$ | -0.24 – 0 | | |
| $\beta_{\text{sor}} \leftarrow \Delta S$ | 0.47 – 0 | | |
| $\beta_{\text{sor}} \leftarrow \Delta t$ | 0.01 – 0.33 | | |
| $\beta_{\text{sor}} \leftarrow \Delta E$ | | 0.16 – 0 | -0.06 – 0.04 |
| $\beta_{\text{sor}} \leftarrow \Delta x$ | 0.09 – 0.01 | | |
| $\Delta S \leftarrow \Delta J$ | 0.29 – 0 | | |
| $\Delta E \leftarrow \Delta t$ | | 0.09 – 0.02 | -0.03 – 0.29 |
| $\Delta E \leftarrow \Delta x$ | | 0.002 – 0.44 | 0.13 – 0.001 |