



HAL
open science

A hybrid genetic algorithm for a multilevel assembly replenishment planning problem with stochastic lead times

Oussama Ben-Ammar, Philippe Castagliola, Alexandre Dolgui, Faicel Hnaien

► **To cite this version:**

Oussama Ben-Ammar, Philippe Castagliola, Alexandre Dolgui, Faicel Hnaien. A hybrid genetic algorithm for a multilevel assembly replenishment planning problem with stochastic lead times. *Computers & Industrial Engineering*, 2020, 149, pp.106794. 10.1016/j.cie.2020.106794 . hal-02935532v1

HAL Id: hal-02935532

<https://hal.science/hal-02935532v1>

Submitted on 16 Mar 2021 (v1), last revised 22 Mar 2021 (v2)

HAL is a multi-disciplinary open access archive for the deposit and dissemination of scientific research documents, whether they are published or not. The documents may come from teaching and research institutions in France or abroad, or from public or private research centers.

L'archive ouverte pluridisciplinaire **HAL**, est destinée au dépôt et à la diffusion de documents scientifiques de niveau recherche, publiés ou non, émanant des établissements d'enseignement et de recherche français ou étrangers, des laboratoires publics ou privés.

A hybrid genetic algorithm for a multilevel assembly replenishment planning problem with stochastic lead times

Oussama Ben-Ammar, Philippe Castagliola, Alexandre Dolgui, Faicel Hnaien

Preprint version, article published: <https://doi.org/10.1016/j.cie.2020.106794>
Computers & Industrial Engineering 149 (2020) 106794

Abstract:

This paper on multi-level assembly systems with several components at each level and deals with the problem of calculating planned lead-times when the real lead-times for all components are assumed to be stochastic. A general probabilistic model is developed to calculate the expected total cost (ETC), composed of the inventory holding cost for components and the backlogging and inventory holding costs for the finished product. A hybrid genetic algorithm (HGA) is introduced to determine the planned order release dates for components at the last level of the bill of materials (BOM) that minimize ETC. Experimental results show that the proposed optimization algorithm efficiently finds good-quality approximate solutions regardless of the type of assembly system, the number of components at the last level and the variability of the finished product –related costs.

Keywords: Assembly systems, Assemble-to-order, Stochastic lead-times, Planned lead-time optimization, Genetic algorithms.

1 Introduction

In an assemble-to-order (ATO) environment, the manufacturer requires several components to assemble a finished product that is custom-tailored to customer requirements. In other words, the demand is not known in advance and there is no stock of finished products planned to anticipate it. The MRP system needs a set of input data (demand and its due date, assembly times, delivery times, etc.) to define the assembly order release dates for components. On one hand, the customer asks, for a given due date, a tailored product composed of a given set of standard or personalized components. On the other hand, the planner needs information on the lead-times of the components (to order them from suppliers or to make and assemble them) and the assembly process to set the delivery time to the customer (d'Avino et al. 2013). This delivery time is often used as the due date (Hammami et al. 2017).

Firms are increasingly implementing ATO strategies. However, uncertainty can disrupt the ATO process it and thus weaken the MRP system (Milne et al. 2015). The assembly process can be interrupted by supply uncertainty (Flynn et al. 2016, Simangungsong et al. 2012, Wazed 2009) and supply disruptions (Snyder et al. 2016, Speier et al. 2011, Kleindorfer and Saad 2005). In practice, machine breakdowns can interrupt the assembly process and extend

the time-to-make. Component customization and replenishment lead-times may also be uncertain and significantly longer or shorter than those planned. The net result is that delays in component delivery are always possible. One component delay will halt of the assembly process and increases the inventory cost for other components already delivered. Consequently, the holding cost of components increases the initial planned cost of production and may delay the delivery of finished products.

MRP logic with deterministic assumptions often proves too limited in ATO environments. In this case, planned lead-times are assumed to be equal to the contractual ones multiplied by a safety coefficient based on the statistical reliability of suppliers (Dolgui and Prodhon 2007). However, the random variability of lead-times drastically decreases the system's performance and thus needs to estimate far more precisely (Bandaly et al. 2016). The majority of the existing academic literature over the past 30 years has argued that MRP logic with deterministic assumptions about time is too restrictive. Several survey papers (Dolgui et al. 2013, Dolgui and Prodhon 2007, Damand et al. 2013, Koh et al. 2002 and Guide and Srivasta 2000) have investigating how MRP systems address lead-time uncertainties find a vast amount of literature highlighting the use safety stocks to handle them, and that the safety lead-times have long been neglected (Van Kampen Tim et al. 2010). Furthermore, there have been very few studies focusing on how to minimize the additional costs caused by the lead-time uncertainty (Dolgui and Prodhon, 2007) or how to anticipate them (Jansen and de Kok (2011). For more details on replenishment planning models under uncertainty, interested readers can refer to Aloulou et al. (2014), Díaz-Madroñero et al. (2014), Dolgui et al. (2013), Dolgui and Proth (2010), Ko et al. (2010), Peidro et al. (2009), Mula et al. (2006b) and Koh et al. (2002).

Despite this interest, no one as far as we know has studied multi-level assembly systems in an ATO environment with non-deterministic lead-time behavior. Here we address this gap by investigating an ATO supply network to assemble a given tailored finished product. The customer's request defines this finished product and the set of customizable components needed to customize it. In our case, there are no product or component stocks available to anticipate this demand and we need to set a due date for client delivery. To do this, the planners use information about the tailored product, customizable components, supplier availabilities and assembly process in order to design the whole supply network, define the list of partners (local assembly units or external suppliers) and estimate the planned lead-times. As highlighted by Golini and Kalchschmidt (2011), Chandra and Grabis (2008), Berlec et al. (2008) and Arda and Hennes (2006), this information is essential in the negotiation step to design the supply network, estimates lead-times and release the orders.

There is usually little information available on the capacity and state of resources and how production is managed at supply chain partner enterprises (suppliers). The only information available to help assess the lead-time of each partner is its probability distribution based on past statistics which includes not only processing times but also additional times related to workload, capacity constraints, local planning decisions, variations, etc. Due to the complexity and often impossibility (e.g. confidentiality) of considering all details on the state

of supply chain partners, this approach has escaped criticism and has been strongly recommended in the literature on contracting and planning under uncertainty (Chen et al, 2019; Jabbarzadeh et al., 2018; Giri and Sarker, 2017; Carvalho et al, 2012; Berlec et al. 2008, Fiala 2005, Song et al. 2000).

In this paper, we are interested in multi-level assembly systems with a fixed finished product demand and stochastic component lead-times, i.e. we want to calculate planned component lead-times for the case of random variability of actual component lead-times for a given order for the finished product and for a given due date. The remainder of the paper is organized as follows: Section 2 reviews the relevant literature, Section 3 describes the problem. Section 4 proposes a model, Section 5 describes an optimization approach with performance tests, and Section 6 rounds off with a conclusion and perspectives for future research.

2 Related publications

The literature features various probabilistic approaches for dealing with lead-time uncertainty in the case of an MRP environment (readers can refer to Díaz-Madroñero et al. 2014, Dolgui et al. 2013, Dolgui and Prodhon 2007, and Mula et al. 2006).

Analytical probabilistic approaches often model the simplest structures (e.g. for one-level systems) and give way to simulation methodology for more complex structures (multi-level systems, multi-period planning, etc.). Several studies have modeled one- or two-level assembly systems under a probabilistic distribution of lead-times (see Table 1). The proposed models consider continuous or discrete random lead-times but remain limited:

- To one-level in the BOM, with constant demand for all periods
- Or to two-levels in the BOM, with mono-period planning (including one customer demand)

For the case of multi-level BOMs, we were the first to propose an analytical approach to model a one customer demand (Ben-Ammar et al., 2014, 2018).

There are also studies based on fuzzy logic. In the area of fuzzy reasoning, statistical data are assumed to be either too unreliable or under-available to obtain reliable probability distributions. Mula et al. (2006b) presented an excellent review of supply and production planning under uncertainty, in which they noted that most studies have focused on handling the uncertainty of demand (Guillaume 2013, Peidro et al. 2009, Grabot et al. 2005, Mula et al. 2006a). This under-focus on the supply side is explained by the difficulty of modeling lead-time variability. Most studies have considered lead-times as null or fixed.

Without attempting an exhaustive review of the literature, we focus here specifically on probabilistic approaches. Dolgui et al. (2013) presented a literature review classifying the techniques and approaches in the field of supply planning and inventory control systems

under stochastic lead-times. As mentioned earlier and described in Table 1, most models have assumed (i) one-level assembly systems and mono- or multi-period planning or (ii) two-level assembly systems and mono-period planning.

Yano et al. (1987a, b) were among the first to note the effects of the variability of lead-times. They proposed the case of serial production systems and mono-period planning, which was later generalized by Elhafsi (2002). In third study (Yano 1987c) studied a two-level assembly system and one-period planning. One component is assembled from two components and lead-times follow stochastic Poisson and negative binomial distributions. The objective function is the expected total cost (ETC), which is composed of tardiness and inventory holding costs. An algorithm based on an exploration of the properties of the objective function determines the optimal planned lead-times. Kumar (1989) studied the case of one-period planning and one-level assembly systems. Like Yano (1987c), he minimized the total expected cost and proposed optimal order release dates. An exact analysis was proposed with assumptions of special types of distribution (normal, uniform and exponential). A few years later, Chu et al. (1993) looked at the case of a one-level assembly system: they proved the convexity of the mathematical expectation of total cost, and proposed an iterative algorithm to minimize it. To solve this issue for the case of a two-stage model production model, Hegedus and Hopp (2001a, b) proposed an approach based on a Newsboy-like analytical formulation. The main weakness in these studies is that they are limited to one- or two-level assembly systems.

Next, Axsäter (2005) considered a three-level assembly network with independent stochastic operation times. The objective was to choose starting times for different operations in order to minimize the ETC, composed of the inventory holding costs of components and the tardiness cost of end items. An approximate decomposition technique, based on the repeat application of the solution of a single-stage problem, was suggested. In the numerical result for the first example of a two-stage problem, there was only 1% error, i.e. the relative cost increase due to approximation. However, for the second three-stage example, the error was about 10%, which cannot be disregarded.

Earlier, Dolgui et al. (1995) and Dolgui (2002) had developed an approach to multi-period planning based on coupling simulation with integer linear programming to model one-level assembly systems. Several types of finished product were produced and assembled from several types of components. An inventory holding cost for each component and a backlogging cost for the finished products were introduced. For each period, the authors optimized the quantity of finished products to be assembled and the quantity of components to be ordered. Proth et al. (1997) studied the same problem and added a heuristic to select which products were to be assembled and which components were to be ordered.

For the case of multi-period models and one-level assembly systems, Ould-Louly and Dolgui (2002a, 2002b, 2004, 2009, 2011, 2013), Ould-Louly et al. (2008a, =2008b) and Shojae (2015) presented mathematical models with random lead-times, a known finished product

demand (the same for all periods) and unlimited assembly capacity. Hnaien and Afsar (2017) recently considered the min-max robust lot-sizing problem with discrete lead-time scenarios and provided a complexity analysis proving that robust lot-sizing problems are NP-hard even when there are two scenarios. They showed that several optimality conditions for the deterministic cases provided in Wagner and Whitin (1958), as well as a classic facility location-based model, were no longer valid. To analyze the effect of lead-time uncertainty, they measured different indicators (backlogging costs, inventory-holding costs, service level and set-up cost), modeled some policies (periodic order quantity (POQ), lot for lot (L4L), economic order quantity (EOQ)) and used several optimization approaches to find optimal release dates for components.

In the cases of one-period planning and two-level assembly systems, Tang and Grubbström (2003) modeled both process times and lead-times for components. They considered a fixed demand, unlimited capacity, and a known due date. A Laplace procedure was used to calculate the optimal safety lead-times to minimize backlogging and inventory holding costs. Later, Hnaien et al. (2009) and Fallah-Jamshidi et al. (2011) treated the same problem using genetic algorithms (GAs) to minimize the expected value of the same total cost. Hnaien et al. (2009) supposed that components at level 1 of the BOM were stored and that the finished product was only assembled after the given due date. Fallah-Jamshidi et al. (2011) explored the same problem but in a multi-objective context, and reinforced the GA by a reliable technique called the electromagnetism-like mechanism.

Hnaien et al. (2016) studied the case of a one-period inventory model for a one-level assembly system under stochastic demand and lead-times. An analytical model and a branch—bound (B&B) approach were found to optimize the component quantities and planned lead-times. Although the authors limited their model to one period, it can be extended to multi-period planning to account for possible trade-offs between stocks from different periods. Building on this work, Borodin et al. (2016) proposed a new approach based on chance-constrained programming and a linear model to solve the same problem. However, they limited themselves to one-level assembly systems because of the dependency between levels. This obstacle can easily be overcome, as in this paper, using separate lead-time uncertainties models at each level.

Atan et al. (2016) recently considered a final assembly process fed by a multi-stage parallel process. Each stage had a stochastic throughput time and the system was controlled by planned lead-times at each stage. The authors developed an iterative heuristic to optimize the planned lead-times for different stages and to minimize the expected cost of a customer order. The problem studied contained a one-assembly process which, if modeled differently by adding planned assembly dates at intermediate levels, could be considered a special case of our study in this paper, and thus be modeled as here and resolved using our optimization approach. More recent papers (Jansen et al. 2018, 2019) feature an interesting investigation on the combination of planned lead-time and commitment lead-time decisions.

In Ben-Ammar et al. (2018), we provided a general probabilistic model and a B&B algorithm to optimize multi-level assembly systems for the case of one customer demand. The objective function is composed of inventory holding costs for components at all levels, and holding and backlogging costs for the finished product. This total cost is expressed as a recursive procedure taking into account inter-level dependency. However, the limitation of this earlier study was that each lead-time varies between 1 and a known upper limit, whereas we observed that the recursive function requires a recursively enumerable domain and depends on the lead-time distribution functions. The major drawback of this recursive procedure is its influence on computation time.

Table 1. Assembly systems

Authors	Criteria	Type of system					Comments
		One-level	Two-level	Multi-level	Multi-period	One-period	
Kumar (1989)	H_c, T_c	✓				✓	Generic study of inventor control
Chu et al. (1993)		✓				✓	Iterative algorithm
Dolgui et al. (1995) Dolgui (2002)		✓			✓		ILP models, simulation, heuristics, optimal reorder point, optimal assembly lot size.
Proth et al. (1997)		✓			✓		Stochastic optimization, heuristic algorithm
Dolgui & Ould-Louly (2002)		✓			✓		Markov, Newsboy, L4L policy, the lead-times of the different types of components follow the same probability distribution
Ould-Louly & Dolgui (2002a)		✓			✓		Markov, Newsboy, all components share identical properties
Ould-Louly & Dolgui (2004)		✓			✓		Markov, Newsboy, POQ policy, components follow the same probability distribution, the same H_c
Ould-Louly and Dolgui (2009)		✓			✓		EOQ policy, B&B
Ould-Louly et al. (2008a)	H_c, S_l	✓			✓		B&B
Ould-Louly et al. (2008b)		✓			✓		Generalization of Ould-Louly and Dolgui (2002a)
Chauhan et al. (2009)	H_c, T_c	✓				✓	Simulated annealing, exacting solutions, continuous model
Ould-Louly & Dolgui (2011)		✓			✓		POQ policy, a new generalization of the Newsboy model
Ould-Louly & Dolgui (2013)	S_c, H_c, S_l	✓			✓		
Shojae et al. (2015)	H_c, S_l	✓			✓		POQ policy, optimization
Borodin et al. (2016)	H_c, T_c	✓				✓	Chance-constrained programming
Hnaïen & Afsar (2017)	S_c, H_c, S_l	✓				✓	MIP models
Yano (1987 c)	H_c, T_c		✓			✓	Nonlinear programming
Hegedus & Hopp (2001)	H_c, S_l		✓			✓	Combinatorial optimization method
Tang & Grubbström (2003)	H_c, T_c		✓			✓	Laplace transform procedure
Hnaïen et al. (2009)			✓			✓	GA, B&B
Hnaïen et al. (2010)		H_c, S_l		✓			✓
Fallah-Jamshidi et al. (2011)	H_c, T_c		✓			✓	Hybrid approach, GA of

							electromagnetism-like mechanism
Sakiani et al. (2012)	H_c, S_i		✓			✓	GA, multi-objective, tournament selection
Guiras et al. (2016)	M_c, H_c, T_c		✓			✓	GA, maintenance cost
Ben-Ammar & Dolgui (2018)	H_c, T_c		✓			✓	B&B & GA
Axsäter (2005)	H_c, T_c		✓*			✓	Approximate decomposition technique, continuous distributions
Ben-Ammar et al. (2018)	H_c, T_c			✓		✓	A recursive formula, B&B
Current paper	H_c, T_c			✓		✓	A generic model, an iterative process, a hybrid GA

(T_c : Tardiness cost, H_c : Holding cost, S_i : Service level, S_c : Set-up cost, M_c : Maintenance cost, ✓*: Three-level)

The purpose of this paper, based on the modeling approach presented in Ben-Ammar et al. (2018), is (i) to develop a more general approach than in the models introduced by Yano (1987a), Chu et al. (1993), Tang and Grubbström (2003), Hnaien et al. (2009), Fallah-Jamshidi et al. (2011), Ben-Ammar et al. (2018) and Ben-Ammar and Dolgui (2018), (ii) to propose a more efficient mathematical model, and (iii) to develop efficient algorithms to resolve large problems.

Moreover, this paper extends and complements preliminary work. In Ben-Ammar and Dolgui (2018), the proposed mathematical model only serves to study two-level assembly systems. In Ben-Ammar et al. (2018), the mathematical model based on recursive formulae serves to study multi-level assembly systems but only with lead-times varying between one and a fixed upper limit. Here, to eliminate this assumption but reduce the initial search space as in Ben-Ammar et al. (2018), we introduce an original technique based on the Newsboy model (see Section 4). Several preliminary works (Ben-Ammar et al. 2014) have indicated that integrating several techniques such as a local search and perturbation is crucial to quickly converge to solution values, but little attention has been given to the theoretical basis of algorithm parameter setting and to the computation time required to solve large problems with more than 6 levels in the BOM. Here, we address this gap by giving these analyses.

3 Problem description

To be closer to the real-world industrial planning methods, we consider a discrete temporal environment and integer decision variables. Figure 1 shows that the finished product is produced from components that are themselves obtained from the next level's components and so on.

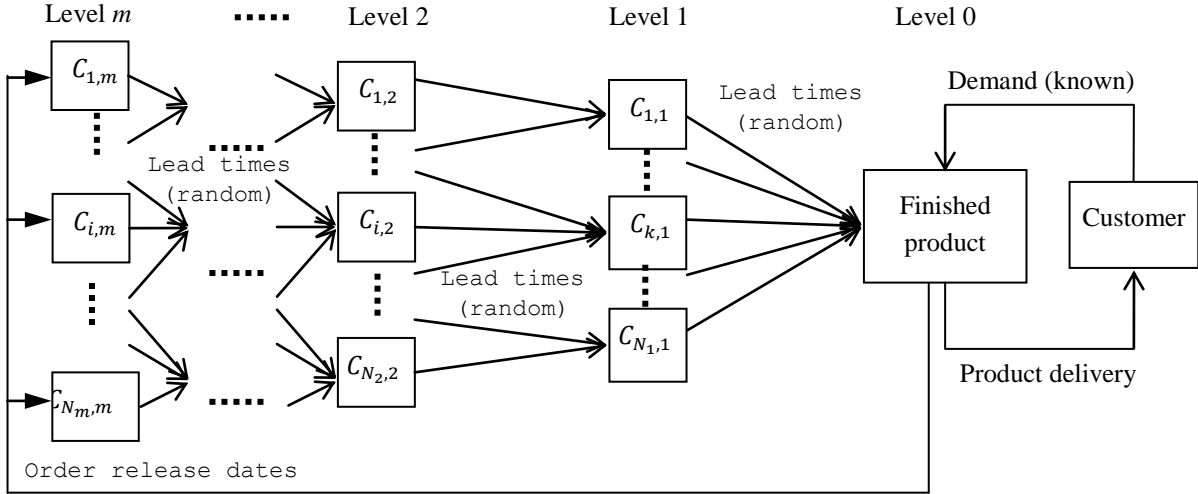

Figure 1. A multi-level assemble-to-order system

To satisfy the customer's request on a tailored finished product, the planner configures the whole supply network according to the desired delivery date and so has to know when the overall processes should be released. Note that our approach is focused on the case of contracting with our customer in an ATO environment. We suppose that all supply chain partners are independent enterprises and that the supply chain will be managed in a decentralized manner. As in Ben-Ammar et al. (2018), we determine only order release dates for components at the last level of the BOM and we assume that there is no decision variable for internal levels (no possibility to account for future local decisions by supply chain partners, and we only know the lead-time probability distributions of our partners). The production cycle thus extends from order release dates of components at the last level to finished-product delivery date.

The assembly system is composed of m levels. At each level, we consider $\forall l = 1, \dots, m, N_l$ components. In this way, $\sum_{l=1}^m N_l$ components are needed to assemble the finished product. Let us assume that: (i) only components $c_{i,m}$ ($i = 1, \dots, N_m$) at the last level m are ordered from external suppliers and their order release dates $X_{i,m}$ ($i = 1, \dots, N_m$) have to be defined; (ii) in local assembly units, components $c_{i,l}$ ($i = 1, \dots, N_l$) at intermediate levels ($l = 1, \dots, m - 1$) are assembled without any decision possible on their start dates; (iii) suppliers and local assembly units are independent.

As in Ben Ammar et al. (2018), without loss of generality, we introduce the following assumptions: the finished product demand D is known and equal to 1, and to assemble it, only one unit of each component is required. The unit backlogging cost b and the unit inventory holding cost r for the finished product, and the unit inventory holding cost $h_{i,l}$ for the component $c_{i,l}$, are known.

The following notations are used in this paper:

Parameters

- T Due date for the finished product, $T > 0$
- D Demand (known) for the finished product at the date T , without loss of generality, let $D = 1$
- l Level in a bill of material (BOM), $l = 1, \dots, m$
- $c_{i,l}$ Component i of level l of the BOM
- N_l Number of components of level l
- $S_{i,l}$ Set of components needed to assemble component $c_{i,l}$
- $L_{i,l}$ Random lead-time for component $c_{i,l}$
- $t_{i,l}$ Minimum value of $L_{i,l}$;
- $u_{i,l}$ Maximum value of $L_{i,l}$; each $L_{i,l}$ varies in $[t_{i,l}, u_{i,l}]$
- $U_{i,m}$ The longest time between the release date for component $c_{i,m}$ and T . Equal to the maximum value of $\sum_{v=1}^m L_{i,v}$; $\forall \theta \in [1, m-1]$ and $\forall c_{i_{\theta+1},l} \in S_{i_{\theta},l-1}$
- $T_{i,m}$ The shortest time between the release date for component $c_{i,m}$ and T . Equal to the minimum value of $\sum_{v=1}^m L_{i,v}$; $\forall \theta \in [1, m-1]$ and $\forall c_{i_{\theta+1},l} \in S_{i_{\theta},l-1}$
- $h_{i,l}$ Unit holding cost for component $c_{i,l}$ per period
- b Unit backlogging cost of the finished product per period
- r Unit inventory holding cost for the finished product per period

Variables

- $X_{i,m}$ Decision variable: release date for component $c_{i,m}$ (this type of variable is defined only for components at level m), $X_{i,m} \in [T - U_{i,m}; T - T_{i,m}]$

Functions

- $E[\cdot]$ Expected value
- $F(\cdot)$ Cumulative distribution function

We use the following notations to simplify several expressions:

- Assembly date for $c_{i,m-1}$:
$$M_{i,m-1} = \max_{c_{k,m} \in S_{i,m-1}} (X_{k,m} + L_{k,m})$$
- Assembly date for $c_{i,l-1}$, $\forall 2 \leq l \leq m-1$:
$$M_{i,l-1} = \max_{\substack{c_{k,l} \in S_{i,l-1} \\ l=2, \dots, m-1}} (M_{k,l} + L_{k,l})$$

- Assembly date for the finished product: $M_{FP} = \max_{i=1, \dots, N_1} (M_{i,1} + L_{i,1})$
- Maximum between M_{FP} and due date T : $M_{FP}^+ = \max(M_{FP}, T)$
- Minimum between M_{FP} and due date T : $M_{FP}^- = \min(M_{FP}, T)$
- $\sum_{i=1}^{N_l} H_i = \sum_{i=1}^{N_l} \left(h_{i,l} - \sum_{c_{k,l+1} \in S_{i,l}} h_{k,l+1} \right)$
- $H = \sum_{i=1}^{N_1} h_{i,1} + b$
- $R = r - \sum_{i=1}^{N_1} h_{i,1}$

4 Mathematical model

The total cost $C(X, L)$ is the sum of the inventory holding or backlogging cost for the finished product and the inventory holding cost for components. Figure 2 gives an example of when the finished product is assembled after the due date. Because of the lead-times uncertainties:

- There is a backlog for the finished product if at least one type of component at level 1 is delivered after the due date T . Then the corresponding backlogging cost is equal to $b \times (M_{FP}^+ - T)$.
- If all components $c_{i,1}, \forall i = 1, \dots, N_1$, at level one are available before T , the finished product may be assembled and stored. The corresponding inventory holding cost is equal to $r \times (T - M_{FP}^-)$.
- The components $c_{k,m}$ at the last level m are ordered at date $X_{k,m}$ and delivered at date $L_{k,m} + X_{k,m}$. Assembly of component $c_{i,m-1}$ begins when all the necessary components $c_{k,m} \in S_{i,m-1}$ are available, i.e. at the date $M_{i,m-1}$. The holding cost of components $c_{k,m}$ at the last level m is equal to:

$$\sum_{i=1}^{N_{m-1}} \left(\sum_{c_{k,m} \in S_{i,m-1}} h_{k,m} (M_{i,m-1} - (X_{k,m} + L_{k,m})) \right)$$

- There are inventories for components $c_{i,l}, l = 2, \dots, m-1, c_{k,l} \in S_{i,l-1}$ during the time period between their arrival at $M_{k,l} + L_{k,l}$ and $M_{i,l-1}$, which is the assembly date for component $c_{i,l-1}$. The corresponding holding cost is equal to:

$$\sum_{l=2}^{m-1} \left(\sum_{i=1}^{N_{l-1}} \left(\sum_{c_{k,l} \in S_{i,l-1}} h_{k,l} (M_{i,l-1} - (M_{k,l} + L_{k,l})) \right) \right)$$

- There are inventories for components $c_{i,1}$, $\forall i = 1, \dots, N_1$ during the time period between their arrival at $M_{i,1} + L_{i,1}$ and M_{FP} , which is the assembly date for the finished product. The corresponding inventory holding cost is equal to:

$$\sum_{i=1}^{N_1} h_{i,1} (M_{FP} - (M_{i,1} + L_{i,1}))$$

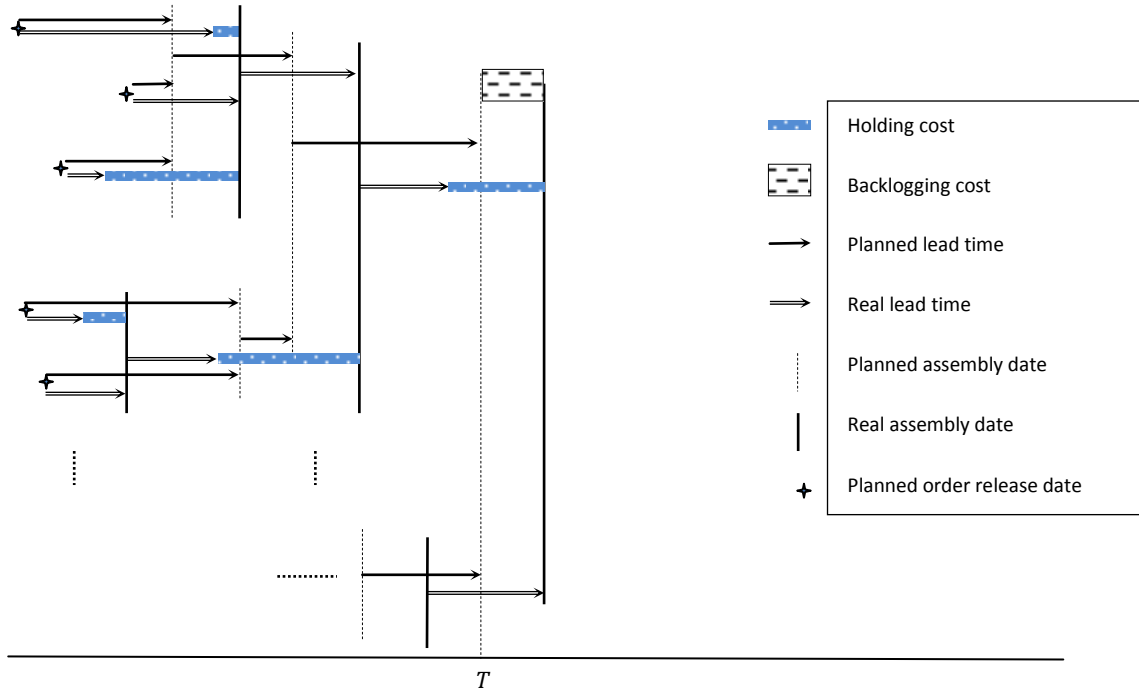

Figure 2. Composition of total cost (in the case of a backlog)

The total cost $C(X, L)$ is a random discrete variable (because the lead-times $L_{i,j}$, $\forall i = 1, \dots, N_j$ and $\forall j = 1, \dots, m$, and assembly dates $M_{i,j}$ are random variables). Its explicit form is demonstrated in Ben-Ammar et al. (2018) and it reads as follows:

$$C(X, L) = \sum_{i=1}^{N_1} h_{i,1} M_{FP} - \sum_{l=1}^{m-1} \sum_{i=1}^{N_l} H_i M_{i,l} - \sum_{l=1}^m \sum_{i=1}^{N_l} h_{i,l} L_{i,l} - \sum_{i=1}^{N_m} h_{i,m} X_{i,m} \quad (1)$$

$$+ b \times (M_{FP}^+ - T) - r \times (T - M_{FP}^-)$$

with $L = (L_{1,1}, \dots, L_{i,1}, \dots, L_{N_1,1}, \dots, L_{1,m}, \dots, L_{i,m}, \dots, L_{N_m,m})$

and $X = (X_{1,m}, \dots, X_{i,m}, \dots, X_{N_m,m})$.

An explicit form of the mathematical expectation of total cost $E[C(X, L)]$ was proposed in Ben-Ammar et al. (2018). Here was develop a new explicit form that avoids using a recursive

function and allows to model actual lead-times $L_{i,l}$ whose variations are between any two limits $t_{i,l}$ and $u_{i,l}$. Note that integrating these two limits, which are time intervals in which assembly dates $M_{i,l}$ vary, is calculated to substantially reduce computation times.

Let Γ be a positive random discrete variable with a finite number of possible values and $F_\Gamma(\cdot)$ be its cumulative distribution function. Its expected value is equal to:

$$E[\Gamma] = \sum_{s \geq 0} (1 - Pr[\Gamma \leq s]) = \sum_{s \geq 0} (1 - F_\Gamma(s)) \quad (2)$$

In Hnaïen et al. (2009), Hnaïen et al. (2010), Fallah-Jamshidi et al. (2011), Sakiani et al. (2012), Hnaïen et al. (2016), Borodin et al. (2016), Guiras et al. (2016) and Ben-Ammar and Dolgui (2018), this expression (2) is used to calculate $E[M_{i,l}]$, $E[M_{FP}^-]$, $E[M_{FP}^+]$ and $E[M_{FP}^-]$ for two-level assembly systems. In our previous work, we were the first to propose a recursive function that expresses the dependence among levels and enabled us to study assembly systems with more than two levels.

Definition 1 (Ben-Ammar et al., 2008)

Let Q^+ be the recursive function that servers to express the dependence among levels. All assembly dates $M_{i,l}$, M_{FP}^- and M_{FP}^+ are positive random discrete variables with a finite number of possible values. Their expected values are as follows:

$$\bullet E[M_{i,l}] = \sum_{s \geq 0} (1 - Q^+(L_{i,l}, s, l)) \quad (3)$$

$$\bullet E[M_{FP}^-] = \sum_{0 \leq s \leq T-1} (1 - Q^+(L_{i,1}, s, 1)) \quad (4)$$

$$\bullet E[M_{FP}^+] = T + \sum_{s \geq T} (1 - Q^+(L_{i,1}, s, 1)) \quad (5)$$

Nevertheless, as mentioned in Appendix in Ben-Ammar et al. (2008), calculating the expected value for an assembly date of a given item (component or finished product) requires using the probability distributions of all the components that compose it. Here we propose an iterative approach to calculate the cumulative distribution function of each assembly date.

Proposition 1

The cumulative distribution function of each assembly date is defined as below:

$$F_{i,m-j-1}(s) = \begin{cases} \prod_{c_{k,m} \in S_{i,m-1}} F_{k,m}(-X_{k,m} + s) & j = 0 \\ \prod_{c_{k,m-j} \in S_{i,m-j-1}} \sum_{\substack{o_j + w_j = s \\ o_j + w_j \in \mathbb{N}}} Pr[[L_{k,m-j} = o_j]] \cdot F_{k,m-j}(w_j) & j = 1, \dots, m-1 \end{cases} \quad (6)$$

where $F_{0,0}(s)$ is the cumulative distribution function of the finished-product assembly date.

Proof

Components $c_{k,m}$ at the last level m are ordered from several suppliers and used to assemble components $c_{i,m-1}$ at level $m-1$. Then, at the first step, the iterative process starts by calculating $F_{i,m-1}(s)$ the cumulative distribution functions of $M_{i,m-1}$, i.e. the assembly dates for components at level $m-1$. These assembly dates $M_{i,m-1}$ are positive random discrete variables with a finite number of possible values. Knowing that $L_{k,m} + X_{k,m}$, for $c_{k,m} \in S_{i,m-1}$, are independent, and that:

$$Pr[[M_{i,m-1} \leq s]] = Pr\left[\max_{c_{k,m} \in S_{i,m-1}} (L_{k,m} + X_{k,m}) \leq s\right] = \prod_{c_{k,m} \in S_{i,m-1}} Pr[[L_{k,m} + X_{k,m} \leq s]]$$

Then:

$$F_{i,m-1}(s) = \prod_{c_{k,m} \in S_{i,m-1}} F_{k,m}(-X_{k,m} + s) \quad (7)$$

Then, at the second step, the iterative process starts by calculating $F_{i,m-2}(s)$, the cumulative distribution function of $M_{i,m-2}$, i.e. the assembly dates for components at level $m-2$. These assembly dates $M_{i,m-2}$ are positive random discrete variables with a finite number of possible values. Knowing that:

$$Pr[[M_{i,m-2} \leq s]] = Pr\left[\max_{c_{k,m-1} \in S_{i,m-2}} (M_{k,m-1} + L_{k,m-1}) \leq s\right]$$

and $\forall k = 1, \dots, N_{m-1}$, the random variables $(M_{k,m-1} + L_{k,m-1})$, are independent, then:

$$\begin{aligned} F_{i,m-2}(s) &= \prod_{c_{k,m-1} \in S_{i,m-2}} Pr[[M_{k,m-1} + L_{k,m-1} \leq s]] \\ &= \prod_{c_{k,m-1} \in S_{i,m-2}} \sum_{\substack{o_1 + w_1 = s \\ o_1 + w_1 \in \mathbb{N}}} [Pr[[L_{k,m-1} = o_1]] \times Pr[[M_{k,m-1} \leq w_1]]] \\ &= \prod_{c_{k,m-1} \in S_{i,m-2}} \sum_{\substack{o_1 + w_1 = s \\ o_1 + w_1 \in \mathbb{N}}} [Pr[[L_{k,m-1} = o_1]] \times F_{k,m-1}(w_1)] \end{aligned}$$

Using expression (7), we obtain the cumulative distribution function of $M_{i,m-2}$:

$$F_{i,m-2}(s) = \prod_{c_{k,m-1} \in S_{i,m-2}} \sum_{\substack{o_1 + w_1 = s \\ o_1 + w_1 \in \mathbb{N}}} \left[Pr[L_{k,m-1} = o_1] \times \prod_{c_{k,m} \in S_{i,m-1}} F_{k,m}(-X_{k,m} + w_1) \right] \quad (8)$$

At the third step, the iterative process starts by calculating $F_{i,m-3}(s)$, the cumulative distribution function of $M_{i,m-3}$ the assembly dates for components at level $m - 3$. These assembly dates $M_{i,m-3}$ are positive random discrete variables with a finite number of possible values. In the same way and using expression (8), we can deduce this cumulative distribution function:

$$F_{i,m-3}(s) = \prod_{c_{k,m-2} \in S_{i,m-3}} \sum_{\substack{o_2 + w_2 = s \\ o_2 + w_2 \in \mathbb{N}}} \left(Pr[L_{k,m-2} = o_2] \times F_{i,m-2}(w_2) \right)$$

Using the same iterative process, the cumulative distribution function of $M_{i,l}$, for $l \in \{m - 4, \dots, 0\}$ are calculated in the same way. ■

In Hnaïen et al. (2009), Hnaïen et al. (2010), Fallah-Jamshidi et al. (2011), Sakiani et al. (2012), Hnaïen et al. (2016), Borodin et al. (2016), Guiras et al. (2016) and Ben-Ammar and Dolgui (2018), the authors assumed that all lead-times $L_{i,l}$, $\forall l \in \{1,2\}$ and $\forall i = 1, 2, \dots, N_2$, vary between 1 and a fixed upper limit. These studies have considered assembly dates as random discrete variables s varying between 0 and $T + U - 2$ with $U = \max(U_{i,2})$ and $U_{i,2} = u_{k,2} + u_{i,1}$ the maximum value of $L_{k,2} + L_{i,1}$ ($c_{k,2} \in S_{i,1}, L_{k,2} + L_{i,1} = 2, \dots, U_{k,2}$). In Ben-Ammar et al. (2018) and our previous work, we generalized these limits and defined s as a natural number such as $0 \leq s \leq T + m \times (u - 1)$. Here we suppose that each lead-time $L_{i,l}$, $\forall l \in \{1, \dots, m\}$ and $\forall i = 1, 2, \dots, N_m$ varies between $t_{i,l}$ and $u_{i,l}$. The mathematical expectation of the total cost, introduced in Ben-Ammar et al. (2018) and previous work, can be simplified by using (6).

Proposition 2

The mathematical expectation of the total cost, noted $E[C(X, L)]$, can be simplified and written as follows:

$$\begin{aligned}
E[C(X, L)] &= R \times \left(\sum_{s=\alpha_{0,0}}^{T-1} F_{0,0}(s) \right) - \sum_{l=1}^{m-1} \sum_{i=1}^{N_l} H_i \times \left(\beta_{i,l} - \sum_{s=\alpha_{i,l}}^{\beta_{i,l}-1} F_{i,l}(s) \right) + H \\
&\times \left(\beta_{0,0} - \sum_{s=T}^{\beta_{0,0}-1} F_{0,0}(s) \right) - b \times T - \sum_{l=1}^m \sum_{i=1}^{N_l} h_{i,l} E[L_{i,l}] \\
&- \sum_{i=1}^{N_m} h_{i,m} E[X_{i,m}]
\end{aligned} \tag{9}$$

Proof

In Ben-Ammar et al. (2018), the general expression of the total expected cost, which is noted $E[C(X, L)]$, was given and written as follows:

$$\begin{aligned}
E[C(X, L)] &= \sum_{i=1}^{N_1} h_{i,1} E[M_{FP}] - \sum_{l=1}^{m-1} \left(\sum_{i=1}^{N_l} H_i \times E[M_{i,l}] \right) - \sum_{l=1}^m \left(\sum_{i=1}^{N_l} h_{i,l} E[L_{i,l}] \right) \\
&- \sum_{i=1}^{N_m} h_{i,m} E[X_{i,m}] + b \times (E[M_{FP}^+] - T) + r \times (T - E[M_{FP}^-])
\end{aligned} \tag{10}$$

Based on expression (2), in our previous work we gave the expressions of $E[M_{i,l}]$, $E[M_{FP}]$, $[M_{FP}^+]$ and $E[M_{FP}^-]$ (see Definition 1). They were calculated independently using the recursive function $Q^+(L_{i,j}, s, j)$. Here, the cumulative distribution functions $F(\cdot)$ of assembly dates (found by an iterative process; see Proposition 1) and the limits $t_{i,l}$ and $u_{i,l}$ of lead-times $L_{i,l}$ are used to simplify the calculations.

For $l = 1, \dots, m$, each $L_{k,l}$ varies in $[t_{k,l}; u_{k,l}]$. Let $\alpha_{i,l} = \max_{c_{k,l+1} \in S_{i,l}} (\alpha_{k,l+1} + t_{k,l+1})$ with $\alpha_{i,m} = X_{i,m}$ and $\beta_{i,l} = \max_{c_{k,l+1} \in S_{i,l}} (\beta_{k,l+1} + u_{k,l+1})$ with $\beta_{i,m} = X_{i,m}$. Thus, $M_{i,l}$ varies between $\alpha_{i,l}$ and $\beta_{i,l}$ (see Figure 3), and expression (3) can be simplified as follows:

$$E[M_{i,l}] = \beta_{i,l} - \sum_{s=\alpha_{i,l}}^{\beta_{i,l}-1} F_{i,l}(s) \tag{11}$$

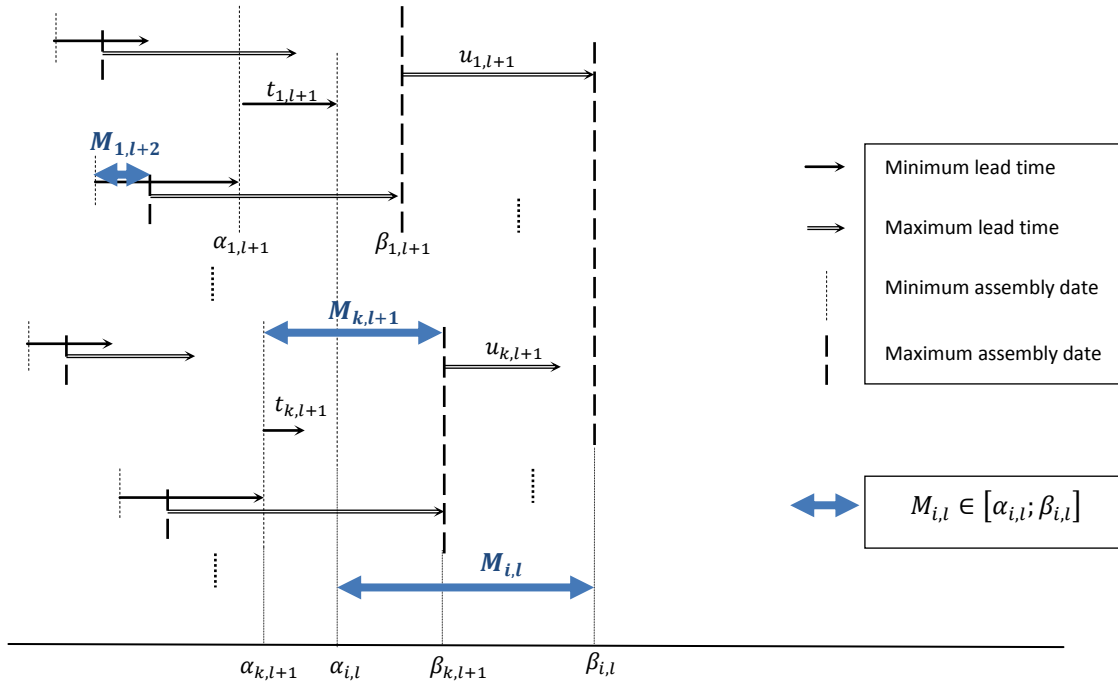

Figure 3. Time interval in which the assembly date $M_{i,l}$ varies

By using the cumulative distribution function defined in expression (6), and knowing that M_{FP}^+ varies between T and $\beta_{0,0} = \max_{k=1,\dots,N_m}(X_{k,m} + U_{k,m})$, $E[M_{FP}^+]$, given in expression (5), can be written as follows:

$$E[M_{FP}^+] = T + \sum_{s \geq T} (1 - F_{0,0}(s)) = \beta_{0,0} - \sum_{s=T}^{\beta_{0,0}-1} F_{0,0}(s) \quad (12)$$

Note that $E[M_{FP}^-]$ is calculated in the same way and is equal to:

$$E[M_{FP}^-] = T - \sum_{s=\alpha_{0,0}}^{T-1} F_{0,0}(s) \quad (13)$$

where $\alpha_{0,0} = \max_{i=1,\dots,N_1}(\alpha_{i,1} + t_{i,1})$.

The expression of $E[M_{FP}]$ is calculated using expressions (12) and (13) and is equal to:

$$E[M_{FP}] = E[M_{FP}^+] + E[M_{FP}^-] - T = \beta_{0,0} - \sum_{s=T}^{\beta_{0,0}-1} F_{0,0}(s) - \sum_{s=\alpha_{0,0}}^{T-1} F_{0,0}(s) \quad (14)$$

Then, using expressions (11, 12, 13 and 14), the mathematical expectation of the total cost in can be found directly. ■

The intervals $T - U_{i,m} \leq X_{i,m} \leq T - m$ are the initial search space which depends on maximum and minimum lead-times and on the number of levels. To reduce their upper limits,

the multi-level assembly system is decomposed to N_m (the number of components at level m) multi-level linear supply chains. A finished product is delivered by each linear chain i , $i \in \{1, \dots, N_m\}$, on a specified delivery date ψ_i . Two costs are taken into account: (i) if a given finished product is delivered after the due date T , a backlogging cost is considered, and (ii) if it arrives before T , an inventory holding cost is assumed. The optimal order release date, noted X_i^{**} , for one linear chain is used to reduce the initial search space for the corresponding component release date at the last level in the BOM.

Definition 2 (Ben-Ammar et al., 2008)

$$T - U_{i,m} \leq X_{i,m} \leq X_i^{**}$$

where the optimal order release date X_i^{**} satisfies the optimality condition for the discrete Newsboy model:

$$\mathcal{F}(T - X_i^{**} - 1) \leq \frac{b}{b+r} \leq \mathcal{F}(T - X_i^{**}) \quad (15)$$

and where $\mathcal{F}(\cdot)$ is the cumulative distribution function of the total lead-time L associated with linear chain i .

In our previous work in Ben-Ammar et al. (2018), in order to solve this non-linear probabilistic problem, we developed bounds and proposed a B&B procedure. Its efficiency depends on the number of levels and the ratio between b (the unit backlogging cost of the finished product per period) and r (the unit inventory holding cost for the finished product per period). In this work, we observed that optimal solutions are computed exactly for small and medium-sized problems with at most 40 components and 3 levels in the BOM. Nevertheless, this branch-and-bound-based approach may not be practical for assembly systems with more than 3 levels in the BOM, as it carries the key limitation that it depends on (i) both backlogging and inventory holding costs and (ii) the number of levels in the structure.

In preliminary work, we tried to develop metaheuristics to determine good quality approximate solutions for larger problems. To achieve a more effective search, our first optimization approach was based on the integration of the classic genetic algorithm (CGA). The structure of this algorithm and preliminary results are presented in Ben-Ammar et al. (2013). However, we observed major drawbacks of this approach: (i) CPU time depends heavily on the number of levels in the assembly system and (ii) a CGA is not guaranteed to converge to a global minimum even though the stopping criterion is fixed to 1000 iterations and the number of components at the last level m (size of each individual). In Ben-Ammar et al. (2014), we proposed several techniques to reinforce the CGA, such as a reduction in the initial space of research (RSR), a local search (LS), and an integration of perturbation (P). These techniques seem to be efficient enough for optimizing only two-level assembly systems with less than 100 components at the last level of the BOM, even though we did not determine the set of parameter values that yields the best performance of the hybrid genetic algorithm (HGA).

Even though our preliminary work improved the efficiency of the HGA, most of the improvements were scattered across several studies that are not reasonably comparable in terms of methodology and results. Nonetheless, it is possible to further improve the efficiency of the approach and group the results. With this goal, the next section describes the techniques used to reinforce the CGA and explains the experiments carried out in order to study the behavior of the HGA.

5 Optimization approach

The problem considered in this paper has a nonlinear objective function with integer variables (see expression 9). We searched the optimal order release dates for the components at level m to minimize the total expected cost $E[C(X, L)]$ under:

$$T - U_{i,m} \leq X_{i,m} \leq X_i^{**}, \forall i \in \{1, \dots, N_m\}$$

This study made partial use of the optimization approach introduced by Ben-Ammar et al. (2014). In our new approach, the CGA presented by Hnaïen et al. (2009) is reinforced by several techniques such as a reduced space of research (RSR), a local search (LS), and the integration of perturbation (P).

Let us use the following set of parameters:

- x_1 Maximum iteration number
- x_2 Population size
- x_3 Crossing-over probability
- x_4 Mutation probability
- x_5 Number of individuals from the initial population that can be a local minimum
- x_6 Number of iterations that have passed without the best solution being improved (only needed to apply the perturbation approach)
- x_7 Number of iterations that have passed without the best solution being improved

The various operations of the proposed HGA are described in Algorithm 1. The stop criterion is that the maximum iteration number, noted x_1 , is reached. The initial population is formed by x_2 individuals. Note that the chromosome representation, the mutation, the crossover and the neighborhood search are done in the same manner as in Hnaïen et al. (2009). However, the only differences concerning these operations are that (i) the length of a given chromosome is N_m , (ii) a given chromosome contains a sequence of order release dates $X_{i,m}$ (integer decision variables), (iii) the crossover and mutation probabilities, noted x_3 and x_4 , will be recalibrated.

As shown in Algorithm 1, the proposed HGA includes several steps. The following subsections discuss some of these steps in detail.

Algorithm 1: Proposed genetic algorithm

```
Function Best_Subset(A,n)
  return  $S \subseteq A, S = n$  and  $s \in S, \nexists s' \in A \setminus S, \text{Fitness}(s') < \text{Fitness}(s)$ 
End Function

 $\text{card}(S\_LO) \leftarrow x_5$ 

 $S\_Pop \leftarrow \text{Initial\_Population}(x_2, x_5)$ 

For  $j \leftarrow 1$  to  $x_1$  do
  // Reproduction Selection //
   $S\_Parents \leftarrow \text{Best\_Subset}(S\_Pop, x_2/2)$ 
  // Evolutionary Operations //
   $S\_Cross \leftarrow \text{Crossover}(S\_Parents; x_3)$ 
   $S\_Mut \leftarrow \text{Mutation}(S\_Parents; x_4)$ 
  // Perturbation //
  If ( $\text{Not\_Convergence}(x_6 \text{ iterations})$ ) then
     $S\_Pop \leftarrow \text{perturbation}(S\_Parents \cup S\_Cross \cup S\_Mut \setminus S\_LO, \text{duplications})$ 
  End if
  // Local Search //
  If ( $\text{Not\_Convergence}(x_7 \text{ iterations})$ ) then
     $\text{Best\_Solution} \leftarrow \text{Best\_Subset}(S\_Parents \cup S\_Cross \cup S\_Mut \setminus S\_LO, 1)$ 
    If ( $\text{Best\_Solution} \notin S\_LO$ ) then
       $LS\_Sol \leftarrow \text{Best\_In\_Neighborhood}(\text{Best\_Solution})$ 
    End if
    If ( $LS\_Sol > \text{Best\_Solution}$ ) and ( $\text{Best\_Solution} \notin S\_LO$ ) then
       $S\_LO \leftarrow S\_LO \cup \text{Best\_Solution}$ 
    Else
       $S\_Parents \leftarrow S\_Parents \cup LS\_Sol$ 
    End if
  End if
  // Replacement Selection //
   $S\_Pop \leftarrow \text{Best\_Subset}(S\_Parents \cup S\_Cross \cup S\_Mut \cup S\_LO, N/2)$ 
End for
```

5.1 Generation of initial population and local search

Choosing the right population at the right size is crucial because it can affect the performance of the algorithm. We use the RSR (see definition 2) exploring the property related to the distribution function of lead-times, and the initial population is generated randomly with uniform distribution as follows:

$$X_{i,m} = \text{Rnd}(T - U_{i,m}; X_i^{**}), \forall i \in \{1, \dots, N_m\}$$

where $Rnd(T - U_{i,m}; X_i^{**})$ is a discrete random value between $T - U_{i,m}$ and X_i^{**} .

In this suggested algorithm, we assume that x_5 individuals can be a local minimum. The procedure, introduced in Hnaïen et al. (2009) and applied one time to obtain the best neighbor solution (*Best_In_Neighborhood*), is considered. Starting out from an individual, all neighbor solutions are explored and the best one is selected to undergo the same operation again. This procedure is applied several times until a local minimum is met. Note that this procedure (*Best_In_Neighbourhood*) is applied on the best solution at a given iteration if and only if (i) the best solution is not a local minimum and (ii) x_7 iterations have passed without the best solution being improved.

5.2 Perturbation approach

The perturbation consists of replacing the solutions which have the same cost by solutions undergoing a special mutation (using block mutation). Each duplication $X = (X_{1,m}, \dots, X_{i,m}, \dots, X_{N_m,m})$ undergoes a modification. To do so, an item (finished product or component) is selected randomly. The order release dates for components $c_{v,m}, \dots, c_{w,m}$ at the last level m that are needed to assemble this item undergo a block mutation. Note that this approach is applied on duplications at a given iteration if and only if x_6 iterations have passed without the best solution being improved.

6 Computational experiments

In this section, we first present the data generation process, then we illustrate the main contribution of this paper and go on to describe the experiments carried out in order to study the effect of multiple factors on HGA performance. We finish by analysing the performance of the HGA.

6.1 Random test instances

We compared our HGA against a heuristic on 140 randomly generated test instances, defined as follows. First, we consider 14 different BOM, and randomly generated 10 instances for each BOM. For different BOMs, the total number of components ($Comp_{total}$) at all levels is equal to 39. We distinguish two types of BOM: B_m and C_m . In the intermediate levels ($l = 1, \dots, m - 1$) of B_m , the number of components at each level N_l is equal to 2, for C_m , $N_l \geq 2$. Table 2 reports the BOM of each assembly system.

Each component lead-time $L_{i,j}, \forall j \in \{1, \dots, 8\}, \forall i \in \{1, \dots, N_j\}$ varies between two limits $t_{i,j}$ and $u_{i,j}$ with a discrete uniform probability distribution. These limits are generated randomly between 1 and 10 with $t_{i,j} < u_{i,j}$. The unit inventory holding costs $h_{i,j}, \forall j \in \{1, \dots, 8\}, \forall i \in \{1, \dots, N_j\}$ for components $c_{i,j}$ and the unit inventory holding and backlogging costs for the finished product are generated as follows: (i) for components at the last level m , $h_{i,m}$ are random between 1 and 40, (ii) for components at level ($l = 1, \dots, m - 1$), $h_{i,l}$ is random between $\alpha = \sum_{c_{k,l} \in S_{i,l}} h_{k,l}$ and 1.2α , (iii) for the finished product, the unit inventory holding

cost r is random between $\alpha = \sum_{c_{k,l} \in \mathcal{E}_{FP}} h_{k,l}$ and 1.2α , and (iv) the backlogging cost b is made to vary in $\{0.1r, 0.5r, r, 5r, 10r\}$.

Table 2. The BOM of each assembly system

	B_2	C_2	B_3	C_3	B_4	C_4	B_5	C_5	B_6	C_6	B_7	C_7	B_8	C_8
N_1	2	4	2	2	2	4	2	2	2	2	2	2	2	2
N_2	37	35	2	4	2	7	2	4	2	4	2	3	2	3
N_3			35	33	2	9	2	8	2	8	2	4	2	3
N_4					33	19	2	9	2	8	2	5	2	4
N_5							31	16	2	8	2	7	2	5
N_6									29	9	2	8	2	5
N_7											27	10	2	6
N_8													25	11
Comp_{total}	39	39	39	39	39	39	39	39	39	39	39	39	39	39

6.2 Comparison between fitness functions

Before we go on to explain the theoretical basis of our HGA parameter setting, we first present the main contribution of this paper. In order to evaluate the efficiency of the proposed model, we carried out several experiments based on the test instances described above.

In this paper, the fitness function, which is an important part of the GA, is the expected total cost $E[C(X, L)]$. A first explicit form of this expected value, noted $V(\cdot)$, was proposed in Ben-Ammar et al. (2018). Here we propose a new explicit form, noted $V^*(\cdot)$ (see Propositions 1 and 2), that avoids using a recursive function and can model real-world lead-times $L_{i,l}$ whose variations are logically between any two limits $t_{i,l}$ and $u_{i,l}$.

We designed a CGA to compute each instance 5 times using $V(\cdot)$ or $V^*(\cdot)$ as fitness function. Without preliminary testing or parameter calibration, the following parameters are fixed: maximum iteration number, noted x_1 , is equal to 1000, population size x_2 is equal to 60 chromosomes, crossing-over probability x_3 is fixed to 0.95, and mutation probability x_4 is equal to 0.05. The CGA and the mathematical models, which calculate the fitness functions $V(\cdot)$ and $V^*(\cdot)$, are coded in C++. The experiments were carried out on a computer with a 1.66 GHz Intel Core 2 Duo CPU and 4 GB of RAM.

Figure 4 illustrates the average CGA execution time after 1000 iterations. $V(B)$ and $V^*(B)$ use the first type of BOM (B_m) and $V(C)$ and $V^*(C)$ use the second type (C_m). Figure 4 shows that the CGA using our new explicit form of $E[C(X, L)]$ as fitness function is less sensitive to the increase in number of levels m than CGA which uses the earlier form given in our last work. Thus, $V^*(\cdot)$ will be used as fitness function in the HGA.

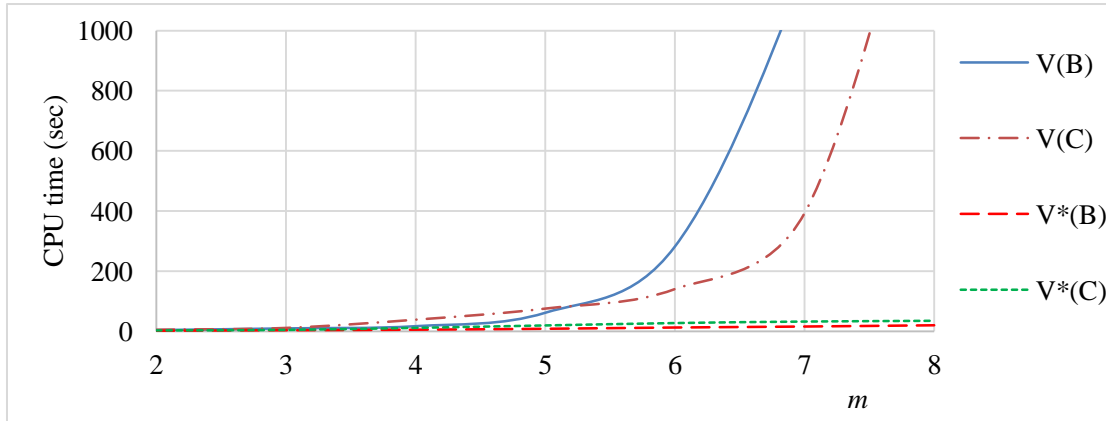

Figure 4. Comparison between fitness functions

6.3 Calibration of parameters and performance measures

In order to find the set of HGA parameters that guarantees optimal performance for our algorithm, we decided to use a ‘design of experiments’ approach based on a standard central composite design (CDD). Based on a reduced number of experiments (see below for details), this kind of 3 level experimental design allows to efficiently fit a quadratic multivariate regression model for which the optimum can be searched for. The set of parameters being investigated is x_1, x_2, \dots, x_7 , which are spelled out Section 5.

The min, middle and max levels for these studied parameters are given in Table 3:

Table 3. Parameters and levels tested

Parameter	Levels		
	Min	Middle	Max
x_1	50	100	150
x_2	40	60	80
x_3	0.85	0.9	0.95
x_4	0.005	0.010	0.015
x_5	0	1	2
x_6	0	10	20
x_7	0	10	20

Note that the backloging cost b is equal to r and a single set of instances was considered. There are 42 instances in each set ($3 \times B_2, 3 \times B_3, \dots, 3 \times B_8, 3 \times C_2, \dots, 3 \times C_8$). Using each combination of parameter values, the algorithm was applied as follows. The set of instances was executed 5 times, and for each execution, we determined the same single performance indicator, i.e. the average expected total cost $E(TC)$ of the best solution found. In order to obtain the $p = 7$ optimal parameters $x^* = (x_1^*, x_2^*, x_3^*, x_4^*, x_5^*, x_6^*, x_7^*)$ of HGA for $E(TC)$, we used a standard CCD with $n = 79$ experiments and $k = 5$ replicates, i.e. 395 observations. The CCD structure thus generated allows to estimate the following quadratic model with 36 coefficients (a_0, a_1, \dots, a_{35}):

$$y = a_0 + a_1x_1 + \dots + a_7x_7 + a_8x_1x_2 + a_9x_1x_3 + \dots + a_{28}x_6x_7 + a_{29}x_1^2 + \dots + a_{35}x_7^2 + \epsilon$$

where ϵ is an error term. Once this model is obtained, we searched for the solution x^* minimizing this quadratic model in the hypercube defined by the *min* and *max* levels listed in Table 3. For $E(TC)$, Table 4 (column headed “coeff”) gives the coefficients $(a_0, a_1, \dots, a_{35})$.

All the rows in Table 4 marked with a “=0” correspond to the regression coefficients (coeff) a_0, a_1, \dots, a_{35} for which the p-value (p-val) is larger than the standard threshold value $\alpha = 0.05$ (5%). As these coefficients are considered statistically equal to 0, their corresponding parameters or parameter combinations are therefore considered as having no influence on response y . For example, concerning $E(TC)$, parameters x_3, x_4 and x_6 seem to be not influential. The estimated model appears to fit the experiments well as the coefficient of determination $R^2 = 0.98216$ is very close to 1. Thus, the vector of optimal parameters is $x^* = (150, 80, 0.9057, 0.0141, 1.20, 11.87, 10.93)$. Knowing that x_5, x_6 and x_7 must be integer values, they are then rounded to the nearest whole the number. Finally, $x^* = (150, 80, 0.9057, 0.0141, 1, 12, 11)$.

6.4 Performance analysis of HGA

For each instance, 100 tests were carried out. The B&B method proposed in Ben-Ammar et al. (2018) requires more than 10 hours to find exact solutions. The CPU times depend not only on (i) number of components in the last level m , (ii) number of levels m and (iii) different costs, but also heavily on (iv) $t_{i,l}$ and $u_{i,l}$, the lower and upper limits of the actual lead-times $L_{i,l}$.

Note that the HGA is reinforced by several techniques, such as a reduced space of research (RSR), a local search (LS) and the integration of perturbation (P). We analyzed the influence of several parameters: (i) type of BOM, (ii) number of levels, and (iii) ratio of backlogging-to-inventory costs (b/r) for the finished product. To analyze the performance of the optimization approach, several notions were introduced:

- Average number of iterations in which the best solution is found;
- Average *gap* between the best solution in the initial population and the best solution $best_{sol_{150}}$ found by the algorithm after 150 iterations: $gap = \frac{best_{sol_0} - best_{sol_{150}}}{best_{sol_{150}}} \times 100$;
- Average *gap** between $best_{sol_{150}}$ and the best-known solution $best_{BKS}$ found among the 100 tests: $gap^* = \frac{best_{sol_{1000}} - best_{BKS}}{best_{BKS}} \times 100$;
- Average CPU time of the HGA when the best solution is found.

Table 4. Standard CCD results for $E(TC)$

Parameters (individual or combinations)	coeff	95% confidence interval		p-val	
1	$a_0 = 4928.12$	809.436	9046.81	0.01916	
x_1	$a_1 = -2.51915$	-3.88487	-1.15343	0.00033	
x_2	$a_2 = -7.52967$	-11.9796	-3.07973	0.00097	
x_3	$a_3 = -5967.82$	-15201.8	3266.11	0.20455	= 0
x_4	$a_4 = -12721.2$	-26378.4	936.033	0.06781	= 0
x_5	$a_5 = -638.405$	-690.446	-586.364	0.00000	
x_6	$a_6 = -2.00088$	-7.205	3.20325	0.45008	= 0
x_7	$a_7 = -7.00097$	-12.2051	-1.79685	0.00851	
x_1x_2	$a_8 = 0.00871653$	0.0062748	0.0111583	0.00000	
x_1x_3	$a_9 = -0.202188$	-1.17888	0.774504	0.68417	= 0
x_1x_4	$a_{10} = -6.90688$	-16.6738	2.86004	0.16517	= 0
x_1x_5	$a_{11} = 0.892039$	0.843205	0.940874	0.00000	
x_1x_6	$a_{12} = -0.0058632$	-0.0107466	-0.00097973	0.01875	
x_1x_7	$a_{13} = -0.0068445$	-0.0117279	-0.00196098	0.00614	
x_2x_3	$a_{14} = 0.366719$	-2.07501	2.80845	0.76789	= 0
x_2x_4	$a_{15} = -24.2203$	-48.6376	0.196984	0.05187	= 0
x_2x_5	$a_{16} = 2.00968$	1.88759	2.13176	0.00000	
x_2x_6	$a_{17} = 0.0171098$	0.0049012	0.0293185	0.00615	
x_2x_7	$a_{18} = 0.00766734$	-0.0045413	0.019876	0.21761	= 0
x_3x_4	$a_{19} = 3452.37$	-6314.54	13219.3	0.48741	= 0
x_3x_5	$a_{20} = 65.6406$	16.806	114.475	0.00857	
x_3x_6	$a_{21} = -2.27581$	-7.15927	2.60765	0.36003	= 0
x_3x_7	$a_{22} = 5.11219$	0.228728	9.99565	0.04024	
x_4x_5	$a_{23} = 2397.03$	1908.69	2885.38	0.00000	
x_4x_6	$a_{24} = 46.2944$	-2.54022	95.129	0.06310	= 0
x_4x_7	$a_{25} = 37.1494$	-11.6852	85.984	0.13553	= 0
x_5x_6	$a_{26} = 0.637528$	0.393355	0.881701	0.00000	
x_5x_7	$a_{27} = 0.225116$	-0.0190573	0.469289	0.07065	= 0
x_6x_7	$a_{28} = 0.0270297$	0.00261239	0.051447	0.03013	
x_1^2	$a_{29} = 0.0030473$	-0.002081	0.0081758	0.24336	= 0
x_2^2	$a_{30} = 0.0195109$	-0.012542	0.0515638	0.23206	= 0
x_3^2	$a_{31} = 3208.54$	-1919.91	8337	0.21936	= 0
x_4^2	$a_{32} = 309094$	-203751	821940	0.23669	= 0
x_5^2	$a_{33} = 99.8044$	86.9832	112.626	0.00000	
x_6^2	$a_{34} = 0.0781836$	-0.0500278	0.206395	0.23123	= 0
x_7^2	$a_{35} = 0.0763036$	-0.0519078	0.204515	0.24262	= 0

Table 5 shows that the number of iterations needed to find the best known solution (BKS) is unaffected by type of BOM and the number of levels. The efficiency of RSR translates through the fact that a big backlogging-to-inventory costs ratio (b/r) slightly reduces the average number of iterations needed to find the BKS. Note too that regardless of the variation of parameters, fewer than 60 iterations are required.

Table 5. Average number of iterations in which the best solution is found

		<i>m</i>						
<i>b/r</i>		2	3	4	5	6	7	8
B	0.1	37.10	49.09	58.56	45.95	36.88	45.09	17.42
	0.5	50.31	21.24	18.42	31.21	14.97	5.75	7.37
	1	2.22	1.61	10.54	16.43	11.88	16.43	4.27
	5	16.92	4.26	17.14	18.67	28.47	15.76	7.66
	10	9.22	9.48	3.63	1.00	1.00	3.37	14.42
	25	17.23	10.76	16.55	5.07	6.04	1.00	4.11
	50	1.33	6.40	7.66	15.37	33.84	14.33	12.38
	100	1.00	7.23	9.81	2.26	2.81	8.29	5.33
	200	1.00	1.00	1.00	11.72	1.00	1.00	1.10
	500	1.00	1.00	1.93	5.22	12.98	1.00	9.67
C	0.1	24.16	31.45	29.89	3.64	10.40	12.22	7.98
	0.5	42.57	50.21	43.51	25.47	24.93	9.20	9.29
	1	18.65	23.52	18.19	6.63	5.49	6.46	12.58
	5	7.79	1.00	9.09	2.95	1.00	2.23	2.81
	10	6.14	4.62	9.58	8.24	7.93	1.06	3.56
	25	2.87	7.99	6.81	1.32	2.59	5.48	5.73
	50	1.00	3.38	3.30	2.48	1.00	1.76	6.08
	100	1.00	9.13	12.61	5.00	4.39	1.18	1.88
	200	1.00	1.00	3.31	1.00	1.61	2.80	8.69
	500	1.00	1.00	4.88	2.67	1.00	2.04	3.60

Table 6 shows the evolution of the average gap as a function of all parameters. This evolution becomes substantial in the case of (i) a small ratio b/r and/or (ii) small number of levels in the BOM. This is explained by the fact that: (i) the search space is biggest for a small b/r and (ii) the number of components at the last level m is big of a small m .

Table 7 shows that, for assembly systems composed from 40 items, the HGA seems to be efficient and is not parameter-dependent. Nevertheless, its performance needs to be further evaluated for more complex systems involving more than 40 items and for a small backlogging cost for the finished product.

Table 8 presents the execution times. Note that the best solutions are always found in less than a second and that the convergence to a good solution does not depend on number of levels, type of the BOM backlogging-to-inventory holding costs ratio.

Table 6. Average *gap* (%)

<i>m</i>

Table 8. CPU time (s)

		<i>m</i>						
<i>b/r</i>		2	3	4	5	6	7	8
B	0.1	0.07	0.14	0.29	0.34	0.34	0.66	0.42
	0.5	0.07	0.07	0.12	0.24	0.21	0.17	0.24
	1	0.01	0.02	0.08	0.15	0.19	0.28	0.20
	5	0.03	0.02	0.10	0.15	0.32	0.26	0.23
	10	0.02	0.03	0.04	0.04	0.08	0.11	0.35
	25	0.02	0.03	0.09	0.06	0.11	0.08	0.16
	50	0.01	0.02	0.05	0.11	0.34	0.22	0.27
	100	0.02	0.04	0.06	0.04	0.08	0.15	0.16
	200	0.02	0.03	0.02	0.09	0.06	0.07	0.10
	500	0.03	0.03	0.02	0.05	0.17	0.06	0.22
C	0.1	0.08	0.13	0.29	0.13	0.44	0.43	0.35
	0.5	0.08	0.19	0.41	0.43	0.66	0.32	0.39
	1	0.04	0.10	0.18	0.17	0.24	0.24	0.44
	5	0.02	0.02	0.11	0.11	0.09	0.15	0.18
	10	0.01	0.03	0.10	0.16	0.25	0.11	0.19
	25	0.01	0.03	0.08	0.07	0.11	0.22	0.23
	50	0.02	0.02	0.05	0.08	0.08	0.11	0.23
	100	0.07	0.04	0.12	0.11	0.13	0.10	0.14
	200	0.07	0.01	0.05	0.06	0.08	0.14	0.38
	500	0.07	0.04	0.07	0.10	0.08	0.12	0.19

For this problem, we used a heuristic and compared its performance against the HGA. It is the upper bound introduced in Ben-Ammar et al. (2018). The solution proposed by this heuristic is equal to the minimum between two variables V_1 and V_2 . As mentioned in Definition 2, we decompose the multi-level assembly system to N_m (the number of components at level m) multi-level linear supply chains. The different $X_{i_m,m}$ are ranked ($Classify(X_{i_m,m}, \omega_{i_m})$) in descending order according to the costs of the linear chains. So, the first $X_{1_m,m}$ has the largest cost $\omega_{i_m} = h_{i_1,1} + h_{i_2,2} + \dots + h_{i_{m-1},m-1} + h_{i_m,m}$. Let us consider two vectors $\Phi = (\phi_1, \phi_2, \dots, \phi_{N_m}) = (T - U_{1_m,m}; T - U_{2_m,m}; \dots; T - U_{N_m,m})$ and $\Psi = (\psi_1, \psi_2, \dots, \psi_{N_m}) = (X_1^{**}; X_2^{**}; \dots; X_{N_m}^{**})$. We start by delaying the order release date ϕ_1 (by advancing ψ_1), and the same operation is executed until the $E[C(\Phi, L)]$ no longer decreases further. Moreover, we then repeat the same operations for order release date ϕ_2 of the next component.

To analyze the performance of the optimization approaches, we introduce the following notions:

- $AGap^*$, average value of all gap^* ;

- $AGapH^*$, average gap between the solution proposed by the heuristic ($best_H$) and the best-known solution $best_{BKS}$ found among the 100 tests: $AGapH^* = \frac{best_H - best_{BKS}}{best_{BKS}} \times 100$;
- $ACPU$ times (s), the average execution time of all CPU times (s) with the HGA when the best solution is found;
- $ACPUH$ times (s), the average execution time of the proposed heuristic.

Algorithm 2: Proposed heuristic
$Classify(X_{i_m,m}, \omega_{i_m});$ $V_1 \leftarrow \emptyset; V_2 \leftarrow \emptyset;$ For k from 1 to N_m do While $E[C(\Phi, L)]$ is decreasing and $\phi_k \leq X_{k_m}^{**}$, do $V_1 \leftarrow E[C(\Phi, L)]$ $\phi_k \leftarrow \phi_k + 1$ Done While $E[C(\Psi, L)]$ is decreasing and $\psi_k \geq T - U_{k_m,m}$, do $V_2 \leftarrow E[C(\Psi, L)]$ $\psi_k \leftarrow \psi_k - 1$ Done Done $UB \leftarrow \min(V_1, V_2);$

In Table 9, looking at the performances of HGA and the proposed heuristic, the b/r ratio seems to influence the quality of the best solutions and the CPU times. Nevertheless, the solutions proposed by the HGA are the best, they are still less than 1% from the best-known solutions found among the 100 tests and less than 6% for the heuristic (see Figure 5). For executions times, both approaches require less than a second (on average) to propose the best solution.

Table 9. Performances of HGA and the proposed heuristic

b/r	0.1	0.5	1	5	10	25	50	100	200	500
$AGap^*$ (%)	0.74	0.37	0.14	0.04	0.01	0.00	0.01	0.03	0.00	0.00
$AGapH^*$ (%)	5.19	3.73	2.95	2.87	2.27	1.45	1.17	0.83	0.84	0.64
$ACPU$ times (s)	0.29	0.26	0.17	0.13	0.11	0.09	0.12	0.09	0.08	0.09
$ACPUH$ times (s)	0.03	0.03	0.03	0.03	0.03	0.02	0.02	0.02	0.02	0.02

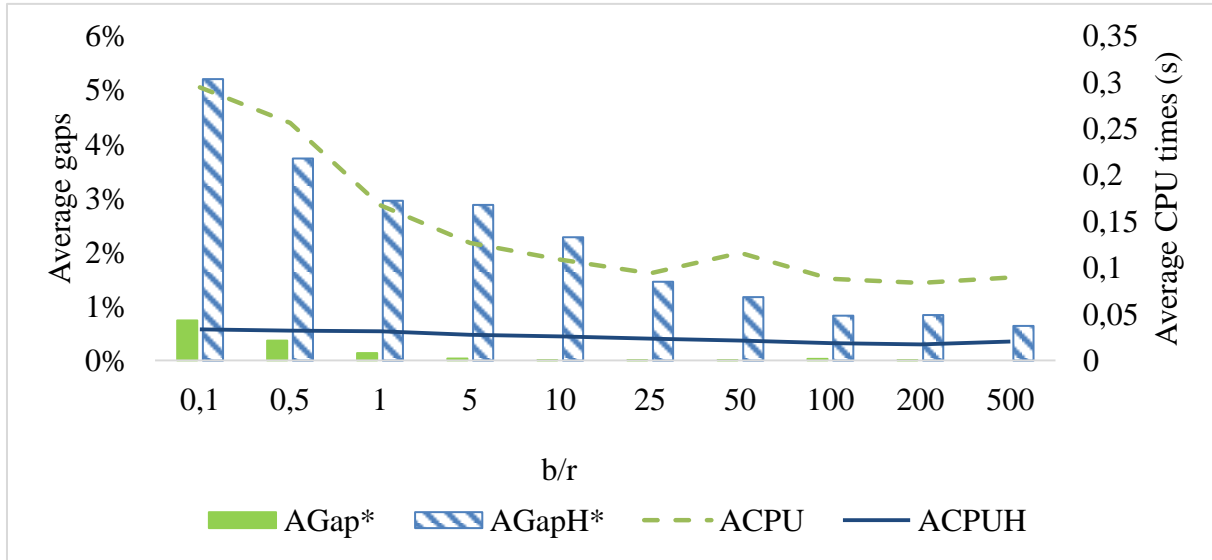

Figure 5. Comparison between the performances of HGA and the proposed heuristic

7 Managerial insights

This paper offers techniques on how to plan replenishments with random lead-times in dynamic ATO environments. To our knowledge, only one other study (Ben-Ammar et al. 2018) has come up with a probabilistic model to study the case of one-period planning for multi-level assembly systems. Here we clearly showed that the newly-developed model and optimization algorithm can, in just a few seconds, compute optimal replenishment release dates for ATO supply networks with more than seven levels. All previous results have been limited to three levels. Even though the emphasis in this work is on the techniques and analytical procedures rather than examples of real-world applications, the proposed model can be used to reduce the impact of lead-time uncertainty in small and medium-sized structures, especially by selecting appropriate planned lead-time parameters in their MRP systems. This dimension of the models is especially true for several industrial examples of manual assembly systems with few levels and few components in the assembly process (typically automotive submodules or electrical appliances, for example). For more complex systems, planners are not necessarily looking for the optimal solutions, and our approach proposed here can generate good-quality solutions within reasonable computation times.

From the practitioner's standpoint, the proposed approach can be successfully used for a number of applications. For example, we have been working with ZF Friedrichshafen AG, a

German car parts maker, at its plant located in Saint-Étienne, France. Based on statistical data, the company allocated, for all suppliers, safety coefficients greater than 1 and used them in calculation of planned lead-times. A coefficient is calculated for each supplier according to its previous delivery performances. To set its planned lead-time in the MRP system, its contractual lead-time is multiplied by the corresponding coefficient. This strategy is applied to anticipate delays and to better assess supplier reliability. Simply put, the lower the coefficient, the more reliable the supplier. The main limitation of this strategy is its inability to provide guarantees since (i) suppliers are considered independently, (ii) the coefficients are assumed empirical and (iii) inventory synchronization aspects and costs are neglected.

We anticipate our findings to offer an excellent initial step towards better estimating these coefficients by taking into account inventory and backlogging costs, the independence (synchronization) of suppliers via the assembly operations, and probability distributions supplier lead-times.

8 Conclusion and future research

In this work, we proposed a model and algorithms to optimize the planned lead-times for multi-level ATO systems working in an MRP environment under uncertainty of actual lead-times. Planned lead-times were determined for the case of multi-level assembly systems with a one-period approach, i.e. for a given customer demand. We assumed an infinite assembly capacity at all levels, a known and fixed demand for the finished product, and independent and identically distributed discrete component procurement times. In this sense, the proposed analytical model calculates the mathematical expectation of the total cost. Our model is a generalization of those proposed in Yano (1987a), Chu et al. (1993), Tang and Grubbström (2003), Hnaien et al. (2008a) and Fallah-Jamshidi et al. (2011).

The same problem was treated in Ben-Ammar et al. (2018), where a recursive procedure was introduced to account for the dependence among levels, and a B&B algorithm was introduced to determine optimum solutions. However, the limitation of that study was that each lead-time varies between one and a known upper limit, and it was observed that the recursive function requires a recursively enumerable domain and depends on the distribution functions. The major drawback of this recursive procedure is its influence on computation time, which becomes far too time-intensive. Here, an iterative approach ensures a significant reduction in the time required to calculate the cumulative distribution function of each assembly date. Here, to optimize the studied problem, we also used and improved various additional techniques introduced in our preliminary work (Ben-Ammar et al. 2014) based on hybrid GAs (HGAs) to find good planned order release dates. The results show that the HGA obtained can very efficiently find good-quality approximate solutions, regardless of the type of assembly system, the number of components at the last levels, and the variability of finished product-related costs related.

Our approach, for a given demand and due date, determines the optimal order release dates for the components, and is therefore readily adaptable to similar ATO environments. Furthermore, our analytical approach can be employed to generalize the models proposed in Ould-Louly et al. (2008a, b), Ould-Louly and Dolgui (2002, 2013), Dolgui et al. (2008) and Shojaie et al. (2015), and can also be applied in disassembly systems under uncertainties (Bentaha et al. 2014).

The current study was not designed to model multi-period planning for multi-level assembly systems. It also carries several limitations. First, it only considers an ATO environment with one demand. Second, we only consider release dates of the entire supply chain from the final assembly point of view, as we assume it is impossible to interact with supply chain partners to globally optimize all release decisions at all intermediate levels. Third, we do not explicitly treat the choice of suppliers. Fourth, we do not integrate supplier-related costs such as purchasing cost and ordering cost. Research is underway to overcome these limitations. We intend to focus on developing mathematical formulations for dynamic supplier selection strategies in multi-period supply planning for assembly systems under stochastic lead-times. Furthermore, our future work will extend this model and the various techniques, in particular to treat some new case studies calculating the planned lead-times when a company has to deal with production and replenishment time uncertainties.

9 References

- Aloulou M.A., Dolgui A., & Kovalyov M.Y., (2014). A bibliography of non-deterministic lot-sizing models. *International Journal of Production Research*, 52(8), p. 1-18.
- Arda, Y. & Henet J.-C. (2006). Inventory control in a multi-supplier system. *International Journal of Production Economics*, 104, p. 249-259.
- Atan Z., de Kok T., Dellaert N.P., Van Boxel R., & Janssen F. (2016). Setting planned lead-times in customer-order-driven assembly systems, *Manufacturing & Service Operations Management*, 18(1), p. 122-140.
- Axsäter S. (2005). Planning order releases for an assembly system with random operation times. *Operations Research Spectrum*, 27, p. 459–470.
- Bandaly D., Satir A., & Shanker L. (2016). Impact of Lead Time Variability in Supply Chain Risk Management. *International Journal of Production Economics*, 180, p. 88-100.
- Ben-Ammar O., & Dolgui A. (2018). Optimal order release dates for two-level assembly systems with stochastic lead times at each level. *International Journal of Production Research*, 56(12), p. 4226-4242.
- Ben-Ammar O., Dolgui A., & Wu DD. (2018). Planned lead times optimization for multi-level assembly systems under uncertainties. *Omega: The International Journal of Management Science*, 78, p. 39-56.
- Ben-Ammar O., Hnaien F., Marian H., & Dolgui A. (2014). Optimization approaches for multi-level assembly systems under stochastic lead times. Chapter in *Metaheuristics for production systems*, L. Amodeo, E-G. Talbi, F. Yalaoui (Eds.), Springer.
- Ben-Ammar O., Marian H., & Dolgui A. (2013). Optimization for supply planning in multi-level assembly systems with stochastic lead-times. *Proceedings of International*

- Conference on Industrial Engineering and Systems Management (IESM 2013). Rabat (Morocco), October 28-30, 2013, 10 pages.
- Bentaha M.L., Battaïa O., & Dolgui A. (2014). A sample average approximation method for disassembly line balancing problem under uncertainty. *Computers & Operations Research*, 51, p. 111-122.
- Berlec T., Govekar E., Grum J., Potocnik P., & Starbek M. (2008). Predicting order lead times. *Journal of Mechanical Engineering*, 54(5), p. 308-321.
- Borodin V., Dolgui A., Hnaien F., & Labadie N. (2016). Component replenishment planning for a single-level assembly system under random lead times: A chance constrained programming approach. *International Journal of Production Economics*, 181, Part A, p. 79 – 86.
- Carvalho, H., Barroso, A. P., Machado, V. H., Azevedo, S., & Cruz-Machado, V. (2012). Supply chain redesign for resilience using simulation. *Computers & Industrial Engineering*, 62(1), 329-341
- Chandra C, & Grabis J. (2008). Inventory management with variable lead-time dependent procurement cost. *Omega*, 36, p. 877-87.
- Chauhan S., Dolgui A., & Proth J.-M. (2009). A continuous model for supply planning of assembly systems with stochastic component procurement times. *International Journal of Production Economics*, 120, p. 411-417.
- Chen, K., Zhao, H., & Xiao, T. (2019). Outsourcing contracts and ordering decisions of a supply chain under multi-dimensional uncertainties. *Computers & Industrial Engineering*, 130, 127-141.
- Chu C., Proth J.-M., & Xie X. (1993). Supply management in assembly systems Naval Research Logistics (NRL), Wiley Subscription Services, Inc., A Wiley Company, 40, p. 933-949.
- Damand D., Derrouiche R., & Barth M. (2013b). Parameterisation of the MRP method: automatic identification and extraction of properties. *International Journal of Production Research*, 51(18), p. 5658-5669.
- D'Avino M., Correale M.-M., & Schiraldi M.-M. (2013). No news, good news: positive impacts of delayed information in MRP. *International Journal of Management and Decision Making*, 12, p. 312-334.
- Díaz-Madroño M., Mula J., & Peidro D. (2014). A review of discrete-time optimization models for tactical production planning, *International Journal of Production Research*, 52, p. 5171-5205.
- Dolgui A., Ben-Ammar O., Hnaien F., & Ould Louly M.-A. (2013). A State of the Art on Supply Planning and Inventory Control under Lead Time Uncertainty. *Studies in Informatics and Control*, 22(3), p. 255-268.
- Dolgui A., & Prodhon C. (2007). Supply planning under uncertainties in MRP environments: A state of the art. *Annual Reviews in Control*, 31, p. 269-279.
- Dolgui A., & Proth J.-M. (2010) Supply chain engineering: Useful techniques and models, Springer: London.
- Dolgui A. (2002). A model of joint control of reserves in automatic control systems of production. *Automation and Remote Control*, 62, p. 2020-2026.

- Dolgui A., & Ould Louly M. (2002). A model for supply planning under lead time uncertainty. *International Journal of Production Economics*, 78, p. 145-152.
- Dolgui A., Portmann M.-C., & Proth J.-M. (1995). Planification de systèmes d'assemblage avec approvisionnements aléatoires en composants. *Journal of Decision Systems*, 4(4), p. 255-278.
- Elhafsi, M. (2002). Optimal leadtimes planning in serial production systems with earliness and tardiness costs. *IIE Transactions*, 34, p. 233-243.
- Fallah-Jamshidi S., Karimi N., & Zandieh M. (2011). A hybrid multi-objective genetic algorithm for planning order release date in two-level assembly system with random lead times. *Expert Systems with Applications*, 38(11), p. 13549-13554.
- Fiala P. (2005). Information sharing in supply chains. *Omega*, 33(5), p. 419-423.
- Flynn B.B., Koufteros X., & Lu G. (2016). On Theory in Supply Chain Uncertainty and its Implications for Supply Chain Integration. *Journal of Supply Chain Management*, 52, p. 3-27.
- Giri, B. C., & Sarker, B. R. (2017). Improving performance by coordinating a supply chain with third party logistics outsourcing under production disruption. *Computers & Industrial Engineering*, 103, 168-177.
- Golini R., & Kalchschmidt M. (2011). Moderating the Impact of Global Sourcing on Inventories through Supply Chain Management. *International Journal of Production Economics*, 133, p. 86-94.
- Grabot B., Geneste L., Reynoso-Castillo G., & Vérot S. (2005). Integration of uncertain and imprecise orders in the MRP method. *Journal of Intelligent Manufacturing*, 16(2), p. 215-234.
- Guillaume, R., Grabot, B., & Thierry, C. (2013). Management of the risk of backorders in a MTO-ATO/MTS context under imperfect requirements. *Applied Mathematical Modelling*, 37, p. 8060-8078.
- Guillaume R., Thierry C., & Grabot B., (2011). Modelling of ill-known requirements and integration in production planning. *Production Planning and Control*, 22 (4), p. 336-352.
- Guiras Z., Turki S., Rezg N., & Dolgui A. (2016). Optimal supply planning for two-levels assembly system with stochastic lead-times and maintenance actions, *2016 IEEE International Conference on Industrial Engineering and Engineering Management (IEEM)*, p. 551-556.
- Hammami R., Frein Y., & Bahli B. (2017). Supply chain design to guarantee quoted lead time and inventory replenishment: model and insights. *International Journal of Production Research*, 55, p. 3431-3450.
- Hegedus M., & Hopp W. (2000). Setting procurement safety lead times for assembly systems. *International Journal of Production Research*, 39, p. 3459-3478.
- Hnaïen F., Delorme X., & Dolgui A. (2009). Genetic algorithm for supply planning in two-level assembly systems with random lead times. *Engineering Applications of Artificial Intelligence*, 22, p. 906-915.
- Hnaïen F., Delorme X., & Dolgui A. (2010). Multi-objective optimization for inventory control in two-level assembly systems under uncertainty of lead times. *Computers and Operations Research*, 37, p. 1835-1843.

- Hnaïen F., & Afsar H.M. (2017). Robust single-item lot-sizing problems with discrete-scenario lead time, *International Journal of Production Economics*, 185, p. 223-229.
- Hnaïen, F., Dolgui, A., & Wu, D. D. (2016). Single-period inventory model for one-level assembly system with stochastic lead times and demand. *International Journal of Production Research*, 54(1), 186-203.
- Ivanov D., Dolgui A., Sokolov B., & Ivanova M. (2017). Literature Review on Disruption Recovery in the Supply Chain, *International Journal of Production Research*, 2017 (accepted, in Press), doi:10.1080/00207543.2017.1330572.
- Jabbarzadeh, A., Houghton, M., & Khosrojerdi, A. (2018). Closed-loop supply chain network design under disruption risks: A robust approach with real world application. *Computers & Industrial Engineering*, 116, 178-191
- Jansen M., Kok T., & Fransoo J. (2013). Lead time anticipation in Supply Chain Operations. *Planning OR Spectrum*, Springer-Verlag, 35, p. 251-290.
- Jansen, S., Atan, Z., Adan, I., & de Kok, T. (2019). Setting optimal planned leadtimes in configure-to-order assembly systems. *European Journal of Operational Research*, 273(2), 585-595.
- Jansen, S., Atan, Z., Adan, I., & de Kok, T. (2018). Newsvendor equations for production networks. *Operations Research Letters*, 46(6), 599–604.
- Karaarslan, G. A., Atan, Z., de Kok, T., & Kiesmüller, G. P. (2018). Optimal and heuristic policies for assemble-to-order systems with different review periods. *European Journal of Operational Research*, 271(1), 80-96.
- Karimi Movahed, K., & Ghodrathnama, A. (2019). Optimal flexible capacity in newsboy problem under stochastic demand and lead-time. *Journal of Industrial Engineering and Management Studies*, 6(1), 18-45.
- Kleindorfer P.R., & Saad, G.H. (2005). Managing disruption risks in supply chains. *Production and Operations Management*, 14(1), p. 53-68.
- Ko M., Tiwari A., & Mehnen J., (2010). A review of soft computing applications in supply chain management. *Applied Soft Computing*, 10(3), p. 661-674.
- Koh S., Saad S., & Jones M. (2002). Uncertainty under MRP-planned manufacture: review and categorization. *International Journal of Production Research*, 40(10), p. 2399-2421.
- Kumar A. (1989). Component Inventory Costs in an Assembly Problem with Uncertain Supplier Lead-Times, *IIE Transactions*, 21, p. 112-121.
- Milne R. J., Mahapatra S., & Wang C. T. (2015). Optimizing planned lead times for enhancing performance of MRP systems. *International Journal of Production Economics*, 167, 220-231.
- Mula J., Poler R., & Garcia J. (2006a). MRP with flexible constraints: A fuzzy mathematical programming approach. *Fuzzy Sets and Systems*, 157(1), p. 74- 97.
- Mula J., Poler R., Garcia-Sabater J., & Lario F. (2006b). Models for production planning under uncertainty: A review. *International Journal of Production Economics*, 103(1), p. 271- 285.
- Ould Louly M. -A., & Dolgui A. (2002a). Generalized newsboy model to compute the optimal planned lead times in assembly systems. *International Journal of Production Research*, 40(17), p. 4401-4414.

- Ould Louly M. -A., & Dolgui A. (2002b). Supply Planning Optimization under Uncertainties. *International Journal of Agile Manufacturing*, 5(1), pp. 17-26.
- Ould Louly M., & Dolgui A. (2004). The MPS parameterization under lead time uncertainty. *International Journal of Production Economics*, 90(04), p. 369-376.
- Ould Louly M. -A., & Dolgui A. (2009). Calculating safety stocks for assembly systems with random component procurement lead times: A branch and bound algorithm. *European Journal of Operational Research*, 199(3), pp. 723-731.
- Ould Louly M. -A., Dolgui A., & Hnaien, F. (2008a). Supply planning for single-level assembly system with stochastic component delivery times and service level constraint. *International Journal of Production Economics*, 115(1), p. 236-247.
- Ould Louly M. -A., Dolgui A., & Hnaien, F. (2008b). Optimal supply planning in MRP environments for assembly systems with random component procurement times. *International Journal of Production Research*, 46(19), p. 5441-5467.
- Ould Louly M. -A., & Dolgui A. (2011). Optimal Time Phasing and Periodicity for MRP with POQ Policy. *International Journal of Production Economics*, 131, no. 1, 2011, pp. 76-86.
- Ould Louly M. -A., & Dolgui A. (2013). Optimal MRP parameters for a single item inventory with random replenishment lead time, POQ policy and service level constraint. *International Journal of Production Economics*, 143(1), p. 35-40.
- Peidro D., Mula J., Poler R., & Lario F.-C. (2009). Quantitative models for supply chain planning under uncertainty: a review. *The International Journal of Advanced Manufacturing Technology*, 43, p. 400-420.
- Proth J.-M., Mauroy G., Wardi Y., & Chu C. (1997). Supply management for cost minimization in assembly systems with random component yield times. *Journal of Intelligent Manufacturing*, 8(5), p. 358-403.
- Sakiani R., Ghomi S.F., & Zandieh, M. (2012). Multi-objective supply planning for two-level assembly systems with stochastic lead times. *Computers & Operations Research*, 39(7), p. 1325-1332.
- Simangunsong E., Hendry L., & Stevenson M. (2012). Supply-chain uncertainty: a review and theoretical foundation for future research. *International Journal of Production Research*, 50, p. 4493-4523.
- Song J., Yano C., & Lerssrisuriya P. (2000). Contract assembly: Dealing with combined supply lead time and demand quantity uncertainty. *Manufacturing Service Operation Management*, 2, p. 287-296.
- Snyder L.V., Atan Z., Peng P., Rong Y., Schmitt A.J., & Sinsoysal B. (2016). OR/MS models for supply chain disruptions: a review. *IIE Transactions*, 48, p. 89-109.
- Shojaie S.H., Bahoosh A., & Pourhassan M. (2015). A Study on MRP with Using Leads Time, Order Quality and Service Level over a Single Inventory. *Journal UMP Social Sciences and Technology Management*, 3(1), p. 235-239.
- Speier C., Whipple J.M., Closs D.J., & Voss M.D. (2011). Global supply chain design considerations: Mitigating product safety and security risks. *Journal of Operations Management*, 29, p. 721-736.

- Tang O., & Grubbström R. (2003). The detailed coordination problem in a two-level assembly system with stochastic lead times. *International Journal of Production Economics*, 81-82, p. 415-429.
- Yano C.A. (1987a). Setting Planned Leadtimes in Serial Production Systems with Tardiness Costs. *Management Science*, 33(1), p. 95-106.
- Yano C.A. (1987b). Planned Lead-times for Serial Production Systems. *IIE Transactions*, 19(3), p. 300-307.
- Yano C.A. (1987c). Stochastic Leadtimes in Two-Level Assembly Systems. *IIE Transactions*, 19, p. 371-378.
- Van Kampen Tim J., Van Donk Dirk P., & Van Der Zee D. (2010). Safety stock or safety lead time: coping with unreliability in demand and supply. *International Journal of Production Research*, 48(23-24), p. 7463-7481.
- Wagner H.M., & Whitin T.M., (1958). Dynamic version of the economic lot size model. *Management Science*, 5(1), p. 89-96.
- Wazed M., Shamsuddin A., & Yusoff N. (2009). Uncertainty factors in real manufacturing environment. *Australian Journal of Basic and Applied Sciences*, 3(2), p. 342-351.