



**HAL**  
open science

# A PCA spatial pattern based downscaling approach for urban flood risk assessment

Julie Carreau, V. Guinot

► **To cite this version:**

Julie Carreau, V. Guinot. A PCA spatial pattern based downscaling approach for urban flood risk assessment. 2020. hal-02903282v1

**HAL Id: hal-02903282**

**<https://hal.science/hal-02903282v1>**

Preprint submitted on 20 Jul 2020 (v1), last revised 8 Dec 2020 (v2)

**HAL** is a multi-disciplinary open access archive for the deposit and dissemination of scientific research documents, whether they are published or not. The documents may come from teaching and research institutions in France or abroad, or from public or private research centers.

L'archive ouverte pluridisciplinaire **HAL**, est destinée au dépôt et à la diffusion de documents scientifiques de niveau recherche, publiés ou non, émanant des établissements d'enseignement et de recherche français ou étrangers, des laboratoires publics ou privés.

# A PCA spatial pattern based downscaling approach for urban flood risk assessment

J. Carreau

*HSM, CNRS, IRD, Univ. Montpellier, France*

V. Guinot

*HSM, CNRS, IRD, Univ. Montpellier, France*

*Inria LEMON, Inria, Univ. Montpellier, France*

---

## Abstract

With CPU times reduced by two to three orders of magnitude compared to shallow water models, porosity models are considered as efficient tools for the modelling of urban floods on the scale of a conurbation. However, they provide only upscaled hydraulic fields that yield unreliable estimates of the flood risk in terms of financial losses and hazard to human lives. Downscaling of the porosity model simulation outputs is thus necessary. The present work puts forward a downscaling approach based on the decomposition of microscopic hydraulic fields into linear combinations of spatial patterns. The coefficients of the linear combinations are predicted with an Artificial Neural Network (ANN) whose input is derived from macroscopic hydraulic fields. Principal Component Analysis is used both to decompose the microscopic fields into linear combinations of spatial patterns and to project the macroscopic fields into lower dimensional features that are fed to the ANN. This global downscaling approach, which reconstruct the whole microscopic field at once, is compared with a local downscaling approach that relies on a similar setup except that each cell of the microscopic field is estimated separately by a dedicated ANN and that there are as many ANNs as cells. The two downscaling approaches are evaluated and compared at estimating the water depth and the norm of the unit discharge on five synthetic urban configurations and one field-test case. The analyses in terms of absolute errors show that the global approach not only provides a valid downscaling scheme but outperforms, in almost all instances, the local approach.

*Keywords:* Shallow water models, Porosity models, Flow variables for risk assessment, Downscaling at multiple locations, Artificial Neural Networks, Principal Component Analysis

---

## 1. Introduction

Two-dimensional shallow water models are widely accepted as a reference approach to the modelling of urban floods. However, they remain too computationally demanding in the current state of computer technology to be applicable to entire conurbations within reasonable computational times. For this reason, upscaled shallow water models have been under development over the past two decades. The earliest upscaled shallow water models were initially

1 developed for the simulation of flows over microtopography and in channels [3, 4, 19]. Versions  
2 specifically dedicated to the modelling of urban floods, known as “porosity models”, were later  
3 developed [9, 25, 26, 24, 27, 47, 38]. A salient advantage of shallow water models with porosity  
4 is their computational efficiency, with CPU times two to three orders of magnitude smaller  
5 than those of classical shallow water models [22, 25, 33]. Porosity models use computational  
6 cells that are typically 10 to  $10^2$  times as wide as those of classical two-dimensional models. As  
7 a consequence, the computational cell of a porosity model contains not only the water domain,  
8 but also buildings and other solid domains in which the flow is zero. The flow equations are  
9 solved on the average over the cells, the areas occupied by the solid phase being accounted  
10 for via statistical, geometric indicators such as porosities. The earliest versions of the model  
11 were developed using a single porosity [19, 24, 27]. More elaborate versions using storage and  
12 connectivity porosities [38, 47, 9, 25] or multiple porosities [22] were later proposed. Other  
13 upscaled versions such as the BCR/CRF model [16] use different indicators, the structure and  
14 function of which, however, bear similarities with the Integral Porosity model [38]. The price  
15 to pay for the computational efficiency of a porosity model is the coarseness of the approach.  
16 Porosity models provide simulation results in the form of upscaled (or averaged) flow variables  
17 over computational cells the size of a house to that of a building block.

18 For practical purposes, the knowledge of the flow fields is required with a much finer res-  
19 olution. This is the case in particular with flood risk mapping. The flood risk results from  
20 the combination of local hydrodynamic factors (such as people’s, buildings’ and goods’ vul-  
21 nerability to the flood hazard) and hydrodynamic variables (derived from the water depths  
22 and flow velocities). As such, it cannot be inferred from the sole knowledge of averaged  
23 flow fields. A first example is that of the assessment of financial flood damage to build-  
24 ings. The water depth is widely recognized as a prominent factor in flood damage modelling  
25 [8, 30, 36, 35, 43]. The damage to buildings is reported to be highly non-linear with respect  
26 to the water depth, which is reflected in most micro-scale flood damage models [44]. Conse-  
27 quently, using average depth values alone cannot be expected to yield reliable vulnerability  
28 assessments. Failing to incorporate such non-linearity on coarser scales is known to provide  
29 substantially erroneous damage estimates [40]. A second example is that of pedestrian vulner-  
30 ability. Pedestrians’ mobility (and with it the likelihood that pedestrians might safely evacuate  
31 high risk areas) is known to be subjected to threshold-based behaviours. When certain flow  
32 variables or their combinations (such as the water depth, unit discharge and specific force per  
33 unit width) exceed given thresholds (that are usually functions of size, age, physical condi-  
34 tion, standing attitude, clothing etc.), pedestrians are likely to slip, tumble or start floating  
35 [1, 6, 15, 14, 18, 21, 29, 31, 32, 34, 41, 45]. In such cases, considered as “danger situations”,  
36 pedestrian evacuation is compromised and lives are at threat. The risk function takes the  
37 form of a step with respect to the local flow variables, a function for which spatial averag-  
38 ing is meaningless. Therefore, in cases such as the two aforementioned examples, a form of  
39 downscaling of the upscaled model simulations is needed to perform relevant risk assessment.

40 In the context of climate change studies, statistical downscaling methods are developed  
41 to bridge the gap between the low resolution of General Circulation Models (GCMs) which

1 is in the order of hundreds of km and the resolution needed for impact studies, from tens of  
2 km down to station locations [2]. Conventional downscaling approaches are univariate, i.e.  
3 they seek to estimate a climatic variable at a single site, either a station or a grid cell, given  
4 information deduced from a simulation generated by a GCM [2]. Artificial Neural Networks  
5 (ANNs) have long been applied in this context [28]. ANNs are non-parametric non-linear  
6 regression algorithms that are considered as “universal approximators”, i.e. they can approxi-  
7 mate any continuous function when trained on informative enough data and provided that the  
8 number of hidden neurons is selected adequately [7]. A choice has to be made concerning the  
9 subset of GCM grid boxes to use as input in the downscaling method. A common approach  
10 consists in selecting all the grid boxes in a sufficiently large region and to reduce their dimen-  
11 sion with Principal Component Analysis (PCA) [2, 28]. More recent downscaling approaches  
12 perform a multivariate estimation by accounting for dependence structures, e.g. to estimate  
13 a climatic variable jointly in several sites. In [42], “Schaake shuffle” is applied to restore the  
14 empirical dependence structure present in a calibration data set thereby assuming that the  
15 co-occurrences of the ranks of the variables always remain the same. This assumption might  
16 be too restrictive in the urban flood risk context as the range of spatial patterns displayed by  
17 the flow field might vary according to values taken by the initial and boundary conditions.  
18 In contrast, [11] relies on univariate techniques applied iteratively to random projections of  
19 the climatic variables. It is not clear that this approach can scale to very high dimensions.  
20 Indeed, refined shallow water models simulate flow variables on meshes that can contain tens  
21 of thousands of discrete cells.

22 In this work, a statistical downscaling approach is proposed that relies on PCA to scale  
23 with the very high dimensions of the refined shallow water models’ simulations and on ANNs  
24 to tackle the potential non-linearities in the relationships between low and high resolution  
25 simulations. PCA is applied on the high resolution flow fields to learn a representative basis  
26 of spatial patterns. The PCA decomposition means that each high resolution field can be  
27 seen as a linear combination of spatial patterns. The coefficients of the linear combination  
28 can be thought of as low dimensional features. An ANN with a feed-forward architecture  
29 and a direct linear connection is set up to learn these low dimensional features that represent  
30 the high resolution flow field. The input of the ANN is, as described above, a projection in a  
31 lower dimensional space of the low resolution field obtained with PCA. This global downscaling  
32 approach that estimates the whole high resolution field at once is compared with a more con-  
33 ventional univariate approach used as a reference. In the reference approach, the flow variable  
34 of interest is estimated at each cell of the high resolution mesh separately by setting up as  
35 many ANNs as there are cells. These two statistical downscaling approaches are evaluated and  
36 compared on a number of typical flooding configurations (a configuration being defined as the  
37 combination of building geometry, initial and boundary conditions). Refined flow simulations  
38 are carried out and exact upscaled solutions are obtained by averaging each reference solution  
39 over a coarse grid. The focus of the downscaling algorithms is on two risk variables : the water  
40 depth and the norm of the unit discharge.

41 The paper is organised as follows. Section 2 presents the reference model, reviews the

1 variables of interest in flood risk assessment and poses the upscaling problem. In particu-  
 2 lar, upscaling, an underlying concept to porosity models but never identified as such in the  
 3 publications, is defined formally for the purpose of the present work. Section 2 ends by intro-  
 4 ducing the downscaling framework used for urban flood risk assessment. Section 3 is devoted  
 5 to the downscaling approaches developed in the present work. Section 4 describes the five  
 6 synthetic configurations and the field-scale test for which simulations of the refined and up-  
 7 scaled solutions are carried out. Section 5 reports the evaluation and the comparison of the  
 8 two downscaling methods. In Section 6, a discussion of the results together with conclusions  
 9 and research perspectives are presented.

## 10 2. Urban flood risk assessment

### 11 2.1. The shallow water model

12 In what follows, the reference, microscopic model is the two-dimensional shallow water  
 13 model, written in conservation form as

$$\partial_t \mathbf{u} + \nabla \cdot \mathbf{F} = \mathbf{s} \quad (1a)$$

14

$$\mathbf{u} = \begin{bmatrix} h \\ q \\ r \end{bmatrix}, \quad \mathbf{F} = \begin{bmatrix} q & r \\ \frac{q^2}{h} + \frac{g}{2}h^2 & \frac{qr}{h} \\ \frac{qr}{h} & \frac{q^2}{h} + \frac{g}{2}h^2 \end{bmatrix}, \quad \mathbf{s} = \begin{bmatrix} 0 \\ gh(S_{0,x} - S_{f,x}) \\ gh(S_{0,y} - S_{f,y}) \end{bmatrix} \quad (1b)$$

$$\begin{bmatrix} S_{f,x} \\ S_{f,y} \end{bmatrix} = \frac{n^2}{h^{10/3}} |\mathbf{q}| \mathbf{q} \quad (1c)$$

15 where  $g$  is the gravitational acceleration,  $h$  is the water depth,  $n$  is Manning's friction coeffi-  
 16 cient,  $\mathbf{q} = (q, r)^T$  is the flow velocity vector,  $(S_{0,x}, S_{0,y})^T$  and  $(S_{f,x}, S_{f,y})^T$  are respectively the  
 17 bottom and friction slope vectors.

### 18 2.2. Variables for risk assessment

19 The water depth  $h$  (and more specifically its maximum with respect to time) influences  
 20 directly the local damage caused to buildings and private property [8, 36, 44, 43]. In addition to  
 21 the water depth, the norm of the unit discharge vector  $|\mathbf{q}|$  and the specific force per unit width  
 22  $f$  are considered key indicators for pedestrian safety assessment [1, 6, 15, 18, 21, 31, 32, 34, 39,  
 23 41, 45]. The water depth is also related to the liability of a pedestrian to start floating [18]. The  
 24 unit discharge is a criterion for pedestrian instability related to tumbling (moment instability),  
 25 while the specific force per unit width is an indicator for friction instability (slipping) [31].  
 26 Moreover, the specific force per unit width is also reported to influence pedestrian evacuation  
 27 speed [29], an important issue to assess and simulate evacuation patterns during floods [6]. The  
 28 hydraulic head has occasionally been mentioned as a criterion for vehicle stability. However,  
 29 it is much less used than the specific force per unit width.

1 It is acknowledged that the above criteria might not be sufficient to fully characterise  
 2 pedestrian stability. For instance, [14, 15] report situations where the classical, steady state-  
 3 based human instability criteria described in previous publications are strongly inaccurate  
 4 because of the non-stationary character of the flow. As a consequence, situations that would  
 5 be considered as “safe” by applying the average value of  $|\mathbf{q}|$  and  $f$  turn out to be hazardous  
 6 when experienced in a real-world event. Moreover, the acceptable threshold for pedestrian  
 7 stability is not only a function of the flow variables but also of the pedestrian’s age, weight  
 8 and size, physical condition, *etc* . . . [18].

9 The analysis reported hereafter focuses on the water depth and the norm of the unit  
 10 discharge vector, that are the most widely acknowledged indicators for flood risk and the  
 11 easiest variables to measure or compute. More precisely, let  $\psi$  be the variable of interest for  
 12 risk assessment derived from  $\mathbf{u} = [h, q, r]^T$ . In what follows

$$\psi = \begin{cases} h & \text{or} \\ |\mathbf{q}| = \sqrt{q^2 + r^2}. \end{cases} \quad (2)$$

### 13 2.3. Upscaling framework

14 As discussed in the introductory section, refined shallow water models such as presented in  
 15 sub-section 2.1 are too computationally demanding to be run on large areas. For this reason,  
 16 porosity-based models have been developed in the past years, with CPU times reduced by  
 17 two to three orders of magnitude compared to refined 2D models. Porosity models, however,  
 18 are only one of the many possible options for upscaling the two-dimensional shallow water  
 19 equations. In what follows, upscaling is understood as a filtering problem, as in [20].

20 Consider a fine-scale (also called microscopic) model obeying a set of governing equations

$$\mathbf{L}_m(\Theta_m, \mathbf{u}_m) = 0 \quad (3)$$

21 where  $\mathbf{L}_m$  is a (vector) differential operator forming the governing equations,  $\Theta_m$  and  $\mathbf{u}_m$  are  
 22 the fine scale parameter and variable vectors. Note that the two-dimensional shallow water  
 23 model (1a)-(1c) is a particular case of the general form (3).

24 Upscaling consists in deriving a model with macroscopic parameters and variables obeying  
 25 a set of macroscopic governing equations

$$\mathbf{L}_M(\Theta_M, \mathbf{u}_M) = 0 \quad (4)$$

26 where the subscript  $M$  denotes the upscaled, or macroscopic, operator, parameter set and  
 27 solution. By assumption, the scale of the fluctuations in  $(\Theta_M, \mathbf{u}_M)$  is larger than that of the  
 28 fluctuations in  $(\Theta_m, \mathbf{u}_m)$ . In other words, the fields  $(\Theta_M, \mathbf{u}_M)$  are significantly smoother than  
 29 the fields  $(\Theta_m, \mathbf{u}_m)$ . Upscaling is understood as the process of deriving  $\mathbf{L}_M$  (model upscaling),  
 30  $\Theta_M$  (parameter upscaling) and/or  $\mathbf{u}_M$  (solution upscaling) from the known microscopic model  
 31 (3).

32 The purpose of a successful upscaling is that the macroscopic solution variable  $\mathbf{u}_M$  be “as

1 close as possible” to the microscopic solution  $\mathbf{u}_m$ . Since  $\mathbf{u}_m$  and  $\mathbf{u}_M$  are usually defined using  
 2 different space-time resolutions, upscaling involves a filtering process. The filtered variable at  
 3 a point  $\mathbf{x} = (x, y)$  is defined as

$$\langle \mathbf{u}_m \rangle (\mathbf{x}) = \int_{\Omega} \mathbf{u}_m (\mathbf{x}') f (\mathbf{x}, \mathbf{x}') d\mathbf{x}' \quad (5)$$

4 where  $f (\mathbf{x}, \mathbf{x}')$  is the filtering kernel and  $\Omega$  is the solution domain. In the case of a perfect  
 5 upscaling, one has

$$\mathbf{u}_M (\mathbf{x}) = \langle \mathbf{u}_m \rangle (\mathbf{x}) \quad \forall \mathbf{x} \in \Omega. \quad (6)$$

6 The most widely used filter in the field of upscaled urban flood models is the averaging operator  
 7 over the computational cells of the macroscopic model:

$$f (\mathbf{x}, \mathbf{x}') = \frac{1}{|\Omega_i|} \epsilon_i (\mathbf{x}, \mathbf{x}') \quad \Rightarrow \quad \langle \mathbf{u}_m \rangle (\mathbf{x}) = \frac{1}{|\Omega_i|} \int_{\Omega_i} \mathbf{u}_m d\Omega_i \quad \forall \mathbf{x} \in \Omega_i \quad (7a)$$

8

$$\epsilon_i (\mathbf{x}, \mathbf{x}') = \begin{cases} 1 & \text{if } (\mathbf{x}, \mathbf{x}') \in \Omega_i \times \Omega_i \\ 0 & \text{otherwise} \end{cases} \quad (7b)$$

9 where  $\Omega_i$  is the subdomain occupied by the  $i$ th computational cell in the macroscopic model  
 10 and  $|\Omega_i|$  is its area. In this approach, the subdomains  $\{\Omega_i\}_i$  form a partition of the overall  
 11 computational domain  $\Omega$ . The filtered microscopic solution  $\langle \mathbf{u}_m \rangle$  is compared directly to  
 12 the finite volume solution  $\mathbf{u}_M$  of the macroscopic model over the computational cells [9, 25, 26,  
 13 33, 47]. Such a comparison is particularly meaningful when  $\mathbf{u}_m$  and  $\mathbf{u}_M$  are both conserved  
 14 variables.

15 Perfect upscaling can be thought of as a particular upscaled solution achieved by applying  
 16 the domain averaging (7a) to the microscopic solution:

$$\mathbf{u}_{M,i} = \frac{1}{|\Omega_i|} \int_{\Omega_i} \mathbf{u}_m d\Omega \quad (8)$$

17  $\mathbf{u}_{M,i} = (h_{M,i}, q_{M,i}, r_{M,i})^T$  thus denotes the average of the conserved flow variable vector over  
 18 the subdomain  $\Omega_i$ . In what follows, the upscaled solution is considered as perfect as defined  
 19 in (8).

#### 20 2.4. Downscaling framework

21 To obtain an operational framework, downscaling methodologies have to be developed in  
 22 order to estimate, with low computational cost, high resolution variables needed for urban  
 23 flood risk assessment, such as the ones in (2), from upscaled ones. It is assumed that an  
 24 upscaled 2D shallow water model has been run for a given domain geometry with given initial  
 25 and boundary conditions over a partition  $\{\Omega_i; 1 \leq i \leq D\}$  of  $\Omega$  into  $D$  subdomains and for  
 26 sample times  $\{t_k\}_k$  of the simulation period  $[0, T]$ . The averaged risk variable, denoted  $\Psi_{i,k}$ ,  
 27 is thus available over each subdomain  $\Omega_i \subset \Omega$  and each time  $t_k \in [0, T]$ . In addition, let  $\{\omega_j\}_j$   
 28 be the cells of a high resolution mesh within  $\Omega$  that could be used to run a microscopic model.

1 Then, downscaling consists in estimating  $\{\psi_{j,k}; \forall k, j\}$ , the high resolution risk variable, from  
 2  $\{\Psi_{i,k}; \forall k, i\}$  based on statistical relationships.

3 To calibrate these statistical relationships to perform downscaling as described, pairs of  
 4 upscaled and microscopic simulations for a given configuration and various initial and boundary  
 5 conditions must be available. The microscopic solution  $\mathbf{u}_m$  is computed by solving the two-  
 6 dimensional shallow water equations (1a)-(1c) numerically over a fine mesh  $\{\omega_j\}_j$ . In this  
 7 work, the upscaled solution is the perfect solution obtained from (8) by averaging the refined  
 8 simulation over the subdomains  $\Omega_i$ . Once calibrated, it is assumed that the downscaling  
 9 relationships can be applied to upscaled simulations for the same configuration but for initial  
 10 and boundary conditions that were not necessarily seen during calibration.

### 11 3. Statistical downscaling approaches

12 A global downscaling approach whose output at any time  $t_k$  is an estimate of the whole field  
 13  $\{\psi_{j,k}; \forall j\}$  of the high resolution risk variable is introduced in subsection 3.2. A local approach  
 14 that performs downscaling for each cell of the high resolution grid separately is presented first  
 15 in subsection 3.1 as some of its building blocks are also used in the global approach.

#### 16 3.1. Local downscaling approach

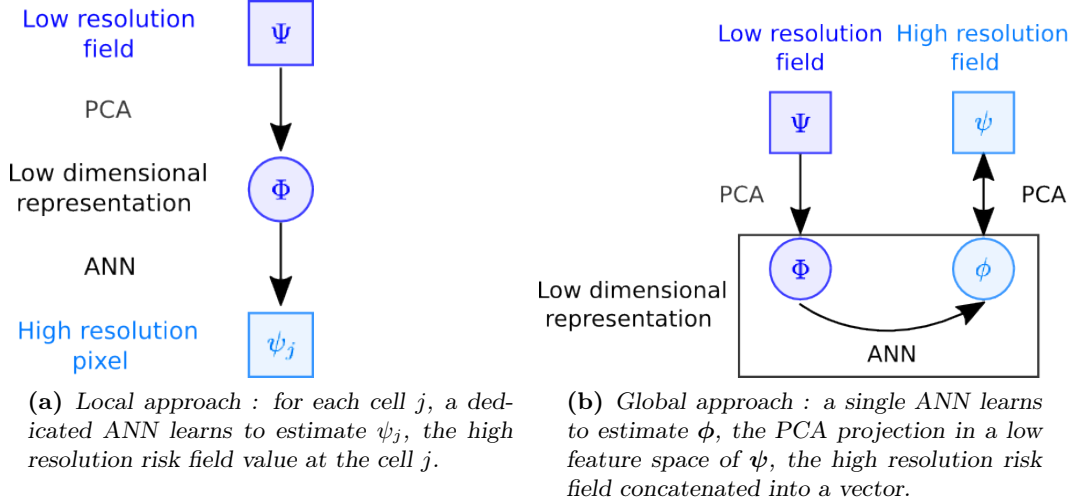
17 This approach seeks to learn a relationship between information drawn from the whole low  
 18 resolution risk field (i.e. over all subdomains) and the value of the high resolution risk field at  
 19 a given cell, see Fig. 1a. There are as many relationships as cells. More precisely, at a given  
 20 time  $t_k$ , let  $\Psi_k \in \mathbb{R}^D$  be the concatenation into a vector of  $\{\Psi_{i,k}; 1 \leq i \leq D\}$ , the averaged  
 21 risk field over all subdomains deduced from the upscaled simulation. The dimension of  $\Psi_k$  can  
 22 be reduced by performing a Principal Component Analysis (PCA) yielding a decomposition  
 23 of the form

$$\Psi_k = A\Phi_k \Leftrightarrow \Phi_k = A^T\Psi_k \quad (9)$$

24 where  $A \in \mathbb{R}^D \times \mathbb{R}^d$  with  $d < D$  and  $\Phi_k \in \mathbb{R}^d$  is the low dimensional representation of  $\Psi_k$ .  
 25 The relationship between the pairs  $\{(\Phi_k, \psi_{j,k})\}_k$  is learned with an Artificial Neural Network  
 26 (ANN). There are as many ANNs as cells  $j$  where  $\psi_j$  needs to be estimated.

27 The ANNs are implemented as shown in Fig. 2a with a standard feed-forward architecture  
 28 that includes one hidden layer plus a direct linear connection such that the case with no neuron  
 29 in the hidden layer boils down to classical linear regression [7]. More precisely, in Fig. 2a, the  
 30 input layer consists of  $\Phi = (\Phi_1, \dots, \Phi_d)$ , the vector of dimension  $d$  of low dimensional features  
 31 extracted by PCA from the upscaled simulation where the dependence on time, i.e. the  
 32 subscript  $k$ , is dropped for convenience ; in addition, there is a special neuron in the input  
 33 layer permanently set to 1 to account for constants in the calculations ; the hidden layer has  
 34  $N_h$  neurons denoted  $a_1, \dots, a_{N_h}$  ; the output layer has a single neuron that yields  $\hat{\psi}_j$ , an  
 35 estimate to the value of the high resolution risk field value at the cell  $j$ . The weight vector  $\mathbf{w}$   
 36 of the ANN includes the weight matrix  $\mathbf{w}^{\text{hid}}$  of dimensions  $(d+1) \times N_h$  connecting the input





**Figure 1:** Common building blocks of the two downscaling approaches : PCA is applied to reduce the dimensionality of  $\Psi$ , the low resolution risk field concatenated into a vector for a given time step, yielding the lower dimensional vector  $\Phi$  used as input vector for the ANN.

1 layer to the hidden layer ; a weight vector  $\mathbf{w}^{\text{out}}$  of length  $N_h$  connecting the hidden layer to  
 2 the output layer and the weight vector  $\mathbf{w}^{\text{lin}}$  of length  $1 + d$  that links directly the input layer to  
 3 the output layer. The calculations performed at the hidden and the output layers, see Fig. 2a,  
 4 are given respectively by

$$a_n(\Phi; \mathbf{w}_n^{\text{hid}}) = \tanh \left( \sum_{i=1}^d w_{n,i}^{\text{hid}} \Phi_i + w_{n,0}^{\text{hid}} \right) \quad n = 1, \dots, N_h \quad (10)$$

$$\hat{\psi}_j(\Phi; \mathbf{w}) = g \left( \underbrace{\sum_{n=1}^{N_h} w_n^{\text{out}} a_n(\Phi; \mathbf{w}^{\text{hid}})}_{\text{non-linear}} + \underbrace{\sum_{i=1}^d w_i^{\text{lin}} \Phi_i + w_0^{\text{lin}}}_{\text{linear}} \right) \quad \text{for a given } j, \quad (11)$$

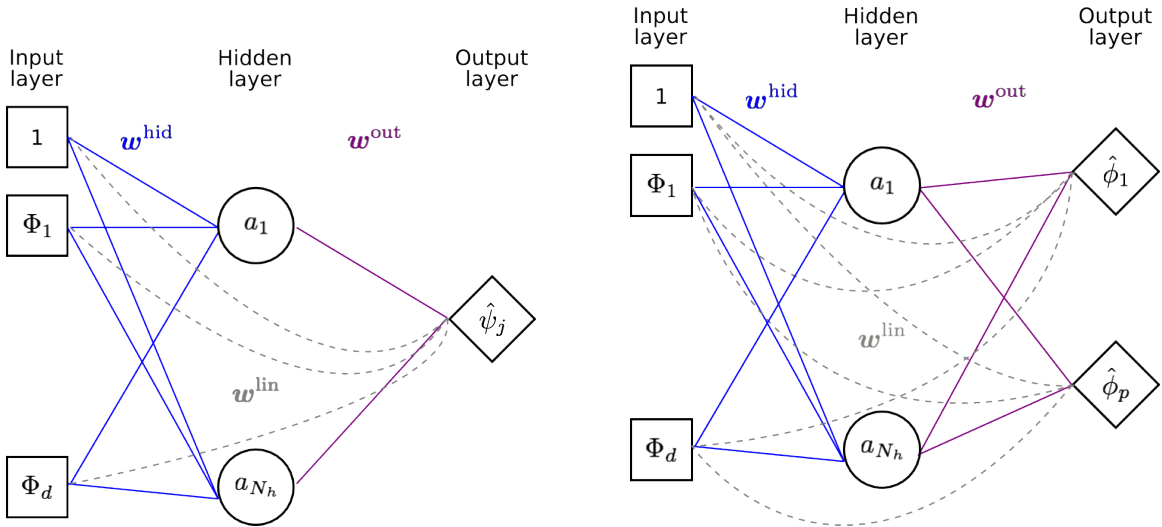
5 where  $g(\cdot) = \log(1 + \exp(\cdot))$  serves to enforce positivity.

6 For each cell  $j$ , an ANN is trained by optimizing its weights  $\mathbf{w}$  so as to minimise, over a  
 7 so-called training set made of pairs of the form  $\{(\Phi_k, \psi_{j,k})\}_k$ , the following sum of squared  
 8 errors :

$$\mathcal{E}_{\text{loc}}(\mathbf{w}; j) = \frac{1}{2} \sum_k (\hat{\psi}_j(\Phi_k; \mathbf{w}) - \psi_{j,k})^2. \quad (12)$$

9 A gradient descent optimisation algorithm is used resorting to the back-propagation algorithm  
 10 to efficiently compute the gradient [37]. The optimisation is performed 10 times with random  
 11 initial parameter values and the optimised parameters yielding the lowest error computed on  
 12 the training set are retained.

13 The hyper-parameters in the local approach are the number of hidden units  $N_h$  in the ANN  
 14 and the dimension  $d$  of the feature space derived from PCA, see (9). Indeed, they control the  
 15 overall number of weights in the ANN which is directly related to the complexity level of the  
 16 function that can be learned by the ANN. Therefore, for each cell  $j$ , suitable values for  $N_h$



(a) Local approach : one ANN for each cell  $j$  with a single output neuron that estimates directly the high resolution risk field value at the cell, see (10)-(11).

(b) Global approach : a single ANN whose output layer seeks to estimate a low dimensional representation of the whole high resolution field, see (10)-(14).

**Figure 2:** Standard feed-forward artificial neural network architectures with one hidden layer plus a direct linear connection used in the two downscaling approaches.

1 and  $d$  must be selected with a validation procedure that works as follows [7]. Several potential  
 2 pairs of values are considered for the hyper-parameters. For each such pair of hyper-parameter  
 3 values, the ANN's weights are optimized on the training set. The performance of the ANN  
 4 associated to each particular choice of hyper-parameter values is evaluated in terms of the sum  
 5 of squared errors as in (12) but computed on a validation set, a data set distinct from the  
 6 training set. The hyper-parameter values yielding the lowest validation error are retained. As  
 7 a result, different hyper-parameter values are likely to be selected for different cells when the  
 8 complexity of the relationship learned by ANNs differ.

### 9 3.2. Global downscaling approach

10 This approach is based on the assumption that the high resolution risk field can be de-  
 11 composed into a linear combination of spatial patterns. A single ANN seeks to estimate the  
 12 weights of the linear combination based on the information drawn from the whole low resolu-  
 13 tion risk field, see Fig. 1b. As for the low resolution risk field, at a given time  $t_k$ , let  $\psi_k \in \mathbb{R}^P$ ,  
 14 be the concatenation into a vector of  $\{\psi_{j,k}; 1 \leq j \leq P\}$ , the high resolution risk field, where  
 15  $P$  is the total number of cells of the high resolution grid. PCA is used again to obtain the  
 16 following linear decomposition

$$\psi_k = B\phi_k \Leftrightarrow \phi_k = B^T\psi_k, \quad (13)$$

17 where  $B \in \mathbb{R}^P \times \mathbb{R}^p$ ,  $p < P$  and  $\phi_k \in \mathbb{R}^p$ . The ANN in this approach seeks to learn the  
 18 relationship between the pairs  $\{(\Phi_k, \phi_k)\}_k$ , see Fig. 2b.

19 To this end, the ANN's calculations at the hidden layer are as in (10) while at the output

1 layer, the ANN has  $p$  neurons which perform the following calculations

$$\hat{\phi}_j(\Phi; \mathbf{w}) = \underbrace{\sum_{n=1}^{N_h} w_{j,n}^{\text{out}} a_n(\Phi; \mathbf{w}^{\text{hid}})}_{\text{non-linear}} + \underbrace{\sum_{i=1}^d w_{j,i}^{\text{lin}} \Phi_i + w_{j,0}^{\text{lin}}}_{\text{linear}} \quad j = 1, \dots, p, \quad (14)$$

2 where, as previously, the time index  $k$  is dropped and  $\mathbf{w}^{\text{out}}$  is now a  $N_h \times p$  matrix instead  
 3 of a vector of length  $N_h$ . The size of the output layer and the absence of positivity constraints  
 4 on the output neurons are thus the only differences with the architecture of the ANNs used in  
 5 the local approach. For any time  $t_k$ , the estimated values of the high resolution risk field are  
 6 given by

$$\hat{\psi}(\Phi_k; \mathbf{w}, B) = B \hat{\phi}(\Phi_k; \mathbf{w}), \quad (15)$$

7 where  $\hat{\phi}(\Phi_k; \mathbf{w}) = (\hat{\phi}_1(\Phi_k; \mathbf{w}), \dots, \hat{\phi}_p(\Phi_k; \mathbf{w}))$  are the ANN outputs as provided in (14) and  
 8  $\Phi_k = A^T \Psi_k$ , see (9).

9 Much like in the local approach except that there is a single ANN to train, the ANN's  
 10 weights  $\mathbf{w}$  are optimized by minimising the following sum of squared errors :

$$\mathcal{E}_{\text{fea}}(\mathbf{w}) = \frac{1}{2} \sum_{j=1}^p \sum_k (\hat{\phi}_j(\Phi_k; \mathbf{w}) - \phi_{j,k})^2. \quad (16)$$

11 The same optimisation strategy as in the local approach is used : best optimised parameters  
 12 out of 10 runs of back-propagated gradient descent algorithm with random initialisations.

13 There are three hyper-parameters in this downscaling approach :  $N_h$  and  $d$ , as in the local  
 14 approach, and  $p$ , the dimension of the feature space of the high resolution risk variable, see  
 15 (13). These hyper-parameters must also be selected with a validation procedure, as described  
 16 in the local approach's subsection. In this case, the sum of squared error that measures the  
 17 performance on the validation set is different than the one in (16) used for training :

$$\mathcal{E}_{\text{tot}}(\mathbf{w}; B) = \frac{1}{2} \sum_{j=1}^p \sum_k (\hat{\psi}_j(\Phi_k; \mathbf{w}, B) - \psi_{j,k})^2. \quad (17)$$

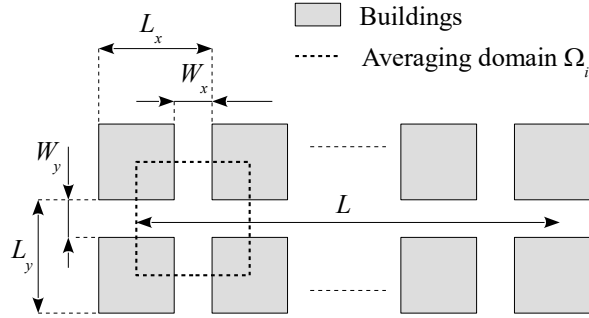
18 In contrast to (16), this validation error takes into account the impact of the choice of  $p$ , the  
 19 dimension of the feature space of the high resolution risk variable.

## 20 4. Low and high resolution simulated data sets

### 21 4.1. Synthetic urban configurations

22 Five synthetic urban configurations are considered. They rely on a common layout con-  
 23 sisting of a periodic array of length  $L$  made of building blocks (see Fig. 3 and Table 1). The  
 24 buildings are aligned along the  $x$ - and  $y$ -directions. The spatial period and building spacing  
 25 in the  $X$ -direction ( $X = x, y$ ) are denoted by  $L_X$  and  $W_X$  respectively. The computational  
 26 domain  $\Omega$  is discretised into a high resolution mesh with  $62.5 \text{ cm} \times 62.5 \text{ cm}$  square cells, for  
 27 46080 cells in total. The subdomains  $\Omega_i$  used to derive the perfectly upscaled solution  $\mathbf{u}_M$  (see

1 (8)) are delineated by connecting the centroids of the building blocks (dashed line in Fig. 3).  
 2 There are 20 such subdomains in total. Other options are available for the definition of  $\Omega_i$ .  
 3 For instance, the subdomains might be centred around the building blocks, or shifted by any  
 4 distance in the  $x$ - and/or  $y$ -direction. Besides,  $\Omega_i$  may include more than one  $x$ - and/or  $y$ -  
 5 building period. The present choice is motivated by two main reasons: (i) the size  $L_x \times L_y$  is  
 6 the smallest possible one that keeps the averaging domain periodic, thus ensuring maximum  
 7 spatial resolution for the upscaled solution, (ii) defining  $\Omega_i$  by connecting the centroids of the  
 8 buildings is consistent with the meshing strategies required by a number of porosity-based  
 9 shallow water models, such as the IP or DIP models [25, 26, 38].



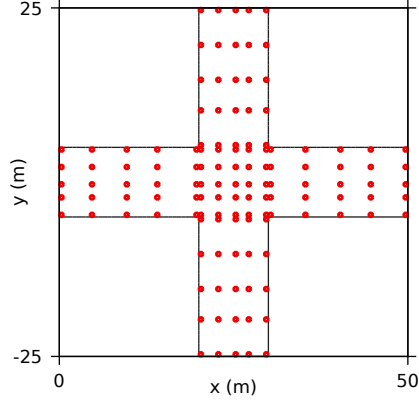
**Figure 3:** Synthetic urban configurations : definition sketch for the geometry.

| Parameter | Meaning              | Numerical value |
|-----------|----------------------|-----------------|
| $L$       | Total domain length  | 1000 m          |
| $L_x$     | $x$ -Period length   | 50 m            |
| $L_y$     | $y$ -period length   | 50 m            |
| $W_x$     | Width of N-S streets | 10 m            |
| $W_y$     | Width of E-W streets | 10 m            |

**Table 1:** Synthetic urban configurations : geometric parameters.

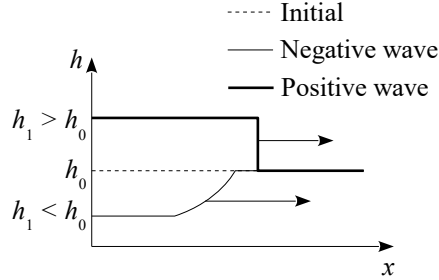
10 In practice, the application of the downscaling approaches is restricted to the cells of the  
 11 high resolution mesh that belong to three subdomains located slightly after the beginning,  
 12 at the middle and slightly before the end of the computational domain. The subdomains'  
 13  $x$ -limits are [250 m, 300 m], [500 m, 550 m] and [750 m, 800 m]. Each subdomain contains  
 14 2304 cells for a total of 6912 cells considering the three subdomains. The global approach  
 15 from subsection 3.2 is applied on the full set of 6912 cells. As the local approach described  
 16 in subsection 3.1 requires to learn a separate relationship for each cell, the number of cells  
 17 was reduced to 125 within each subdomain to keep the computation time within reasonable  
 18 limits. For each of the three subdomains, the 125 cells are selected as follows, see Fig. 4. The  
 19 subdomain is divided into 5 rectangular zones : one for the central crossroads and four for  
 20 each of the branches departing from the intersection. Each of these five zones comprises  $5 \times 5$   
 21 cells spread regularly so as to allow for a maximum coverage of the rectangular zone.

22 The first two synthetic configurations considered are 1D negative and positive waves with-  
 23 out friction that are 1D Boundary Value Problems (BVPs). These configurations, identified  
 24 as **N-wave-nf** and **P-wave-nf** respectively for short, are one of the simplest possible BVPs for  
 25 layouts of this type. The frictionless propagation along the  $x$ -direction of a wave into still



**Figure 4:** Synthetic urban configurations : locations of the 125 cells within a given subdomain. The origin of the coordinates are taken from the SW corner of the subdomain.

1 water is simulated (Fig. 5). The bottom is flat, the water is initially at rest in the domain,  
 2 with an initial depth  $h_0$ . The water level is set instantaneously to a constant value  $h_1$  at  
 3 the Western boundary of the domain. In **N-wave-nf**,  $h_1 < h_0$ , which yields a negative wave  
 4 (rarefaction wave). In **P-wave-nf**,  $h_1 > h_0$  and a positive wave (shock wave) appears. The  
 5 macroscopic solution  $\mathbf{u}_M$  is self-similar in the  $(x, t)$  domain [23, 25, 26].

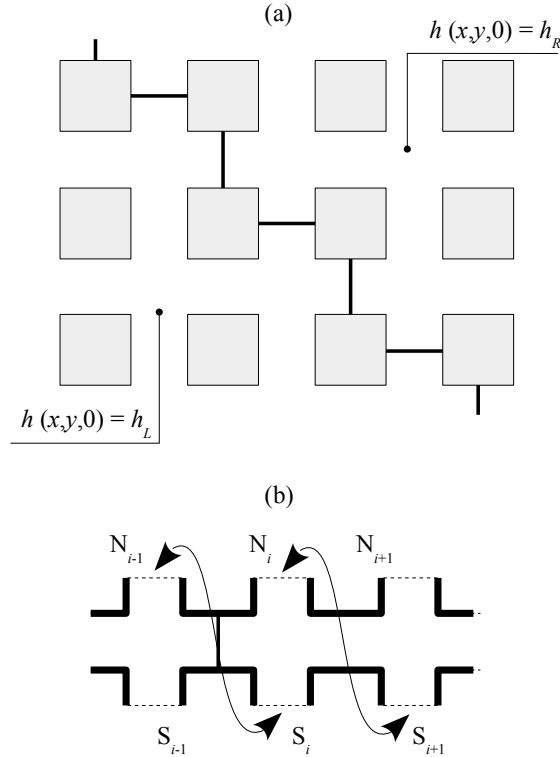


**Figure 5:** Negative and positive wave configurations : initial and boundary condition definition sketch.

6 The next two synthetic configurations use the same geometry as **N-wave-nf** and **P-wave-nf**  
 7 (Fig. 5) but with a non-zero bottom friction coefficient. These configurations, identified as  
 8 **N-wave-wf** and **P-wave-wf** respectively, are cases study closer to real-world situations. As a  
 9 consequence of the non-zero friction coefficient, the upscaled solution is no longer self-similar  
 10 in the  $(x, t)$  space. Both the microscopic and upscaled solutions and their spatial gradients  
 11 span a different range of hydraulic configurations from that of **N-wave-nf** and **P-wave-nf**.

12 The last synthetic configuration, identified as **Dam-break**, is a 2D oblique urban dam break  
 13 problem. The dam break problem is a Riemann, Initial Value Problem (IVP) where the water  
 14 is initially at rest and the water depth is piecewise constant, equal to  $h_L$  and  $h_R$  respectively  
 15 on the left- and right-hand sides of a broken, divide line with average orientation SE-NW  
 16 (Fig. 6a). This results in an average flow field and wave propagation pattern oriented in the  
 17 SW-NE direction. Since the flow is diagonal to the main street directions, fully meshing the  
 18 domain involves as many block periods in both directions of space. This makes the mesh size  
 19 and the subsequent computational effort prohibitive. The difficulty can be overcome [23] by

1 meshing only a single block period in the transverse direction (Fig. 6b). The topology of the  
 2 mesh is modified by connecting the Northern side of the  $i$ th lateral street (boundary segment  
 3  $N_i$  in the Figure) with the Southern side of the  $i + 1^{\text{th}}$  lateral street (boundary segment  $S_{i+1}$   
 4 in Fig. 6b). While the upscaled solution of an urban dam break problem parallel to the main  
 5 street axis is known to be self-similar in  $(x, t)$  [22, 25, 23], self-similarity disappears when the  
 6 propagation is oblique with respect to the street axes [23].

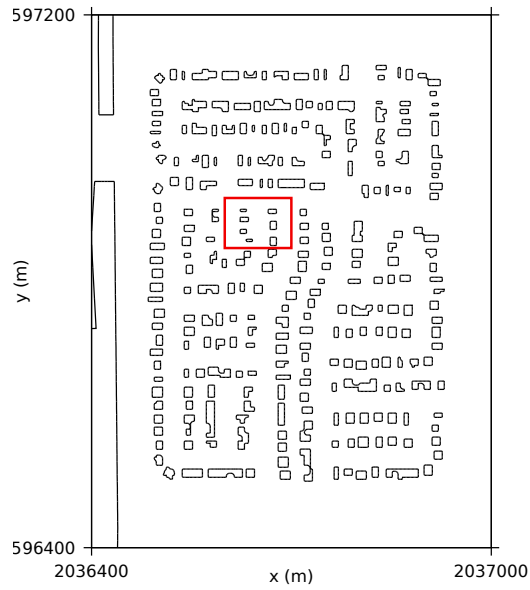


**Figure 6:** 2D oblique dam break problem. Definition sketch : (a) building layout and IVP geometry in plan view (b) periodic model mesh for computational efficiency. Bold lines: impervious boundaries. Dashed lines: boundary segments with staggered connection scheme.

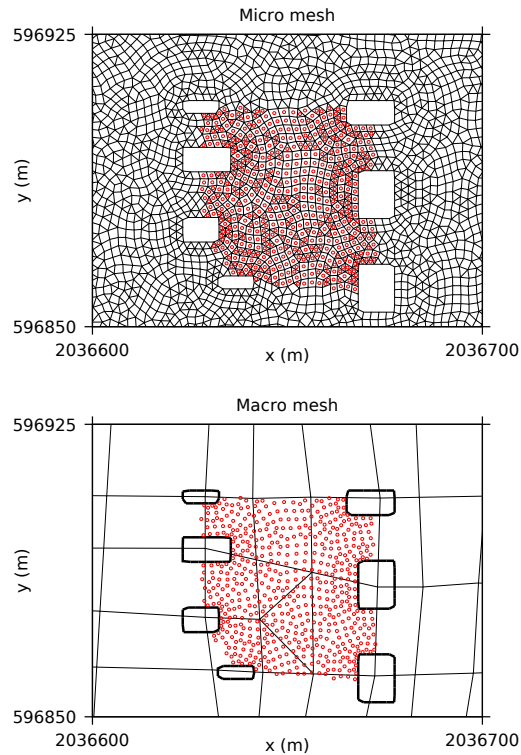
#### 7 4.2. Field-scale test case

8 The field-scale test case considered was reported in [25] for the evaluation of a porosity-  
 9 based, shallow water model. The propagation of a dike break flood wave into a neighbourhood  
 10 of the Sacramento urban area is simulated. The test, which is referred to as **Sacramento** for  
 11 short, is informative in many aspects: (i) the geometry is real, non-periodic, (ii) the upscaled  
 12 hydraulic pattern is genuinely two-dimensional, and (iii) the microscopic flow field exhibits  
 13 a strong polarisation along two preferential flow directions [25]. The dike breach is located  
 14 on the left-hand side of the domain in Fig. 7. The Sacramento neighbourhood is discretised  
 15 using a microscopic mesh made of 77 963 cells (average cell area  $6.5 \text{ m}^2$ ). The macroscopic  
 16 mesh used for upscaling is much coarser, with 1682 subdomains (average subdomain area  $285$   
 17  $\text{m}^2$ ). These two meshes are used for the refined and porosity-based shallow water simulations  
 18 reported in Guinot *et al.* [25]. Fig. 8 shows close-up views of the microscopic and macroscopic  
 19 meshes of the area where the 575 cells on which the local downscaling approach is applied are

1 located. In contrast, the global downscaling approach is applied on the full set of 77 963 cells.



**Figure 7:** Field-scale test : Sacramento neighbourhood with the bold rectangle indicating the zooming areas in Fig. 8.



**Figure 8:** Field-scale test (Sacramento) : area where the 575 cells (shown as red dots) on which the local downscaling approach is applied are located. Top: microscopic mesh. Bottom: macroscopic mesh.

## 2 4.3. Training, validation and test sets

3 Training sets are defined to optimise the parameters of each downscaling approach (i.e. the  
4 ANNs' weights), validation sets to select optimal hyper-parameter values for each downscaling

1 approach and test sets to compare the performance of the two downscaling approaches. These  
 2 sets are made of a number of pairs of micro and macro simulations from the same configuration  
 3 but with different values for the BC and/or IC. The underlying rationale is that, in a practical  
 4 application, it is assumed that the configuration - such as positive or negative waves - can  
 5 be known *a priori* but the appropriate values of BC and/or IC cannot. As a consequence,  
 6 downscaling approaches should perform well, given a configuration, for any BC and/or IC  
 7 values.

8 The values of BC and/or IC used to define the training, validation and test sets are labelled  
 9 by a letter as indicated in Table 2 for the synthetic urban configurations and in Table 3 for the  
 10 field-scale test. Fig. 9 illustrates the principle of the training-validation-test sets' design. The  
 11 training set is designed so as to cover representative BC and/or IC values. For the synthetic  
 12 urban configurations, there are three pairs of BC and/or IC values taken so as to form a right-  
 13 angled triangle in the BC and/or IC space, see Fig. 9, whereas for the test-field case, there is  
 14 a single initial condition for which two values are considered. The validation set includes two  
 15 pairs of BC and/or IC values for the synthetic urban configuration taken as the midpoints of  
 16 the two legs of the right-angled triangle while for the test-field case, a single value of the IC  
 17 is considered for the validation set, the midpoint between the values forming the training set.  
 18 The test set concerns BC and/or IC values that are different from those seen for training and  
 19 validation. For the synthetic urban configurations, five such pairs of BC and/or IC values are  
 20 considered. The field-scale test, in contrast, has only two possible IC values that form the test  
 21 set.

| Set        | Label | N-wave-nf / wf<br>( $h_0, h_1$ ) (m) | P-wave-nf / wf<br>( $h_0, h_1$ ) (m) | Dam-break<br>( $h_L, h_R$ ) (m) |
|------------|-------|--------------------------------------|--------------------------------------|---------------------------------|
| Training   | a     | (1, 0.9)                             | (0.9, 1)                             | (3, 2.5)                        |
|            | b     | (1, 0.5)                             | (0.5, 1)                             | (3, 0.5)                        |
|            | c     | (0.6, 0.5)                           | (0.5, 0.6)                           | (1, 0.5)                        |
| Validation | d     | (0.8, 0.5)                           | (0.7, 1)                             | (2, 0.5)                        |
|            | e     | (1, 0.7)                             | (0.5, 0.8)                           | (3, 1.5)                        |
| Test       | f     | (0.85, 0.75)                         | (0.65, 0.85)                         | (2.3, 1.2)                      |
|            | g     | (0.8, 0.4)                           | (0.7, 1.5)                           | (2, 0.01)                       |
|            | h     | (1, 0.7)                             | (0.3, 0.8)                           | (5, 1.5)                        |
|            | i     | (0.4, 0.3)                           | (0.3, 0.4)                           | (0.1, 0.01)                     |
|            | j     | (1.5, 1)                             | (1.3, 1.5)                           | (5, 4.5)                        |

**Table 2:** Training, validation and two test sets for the synthetic urban configurations in terms of BC and/or IC values. The BC and/or IC values for the negative waves N-wave-nf / wf are not exact mirrors of those for positive waves P-wave-nf / wf in order to ensure the feasibility of boundary condition prescription.

| Set        | Label | $h_0$ (m) |
|------------|-------|-----------|
| Training   | a     | 6 m       |
|            | b     | 4.5 m     |
| Validation | c     | 5.25 m    |
| Test       | d     | 3.5 m     |
|            | e     | 7 m       |

**Table 3:** Field-scale test (Sacramento). Values of  $h_0$ , the initial water depth in the channel, used to form the training, validation and test sets.

22 The length of the simulation period  $T$  and the sampling time step are set as follows (see



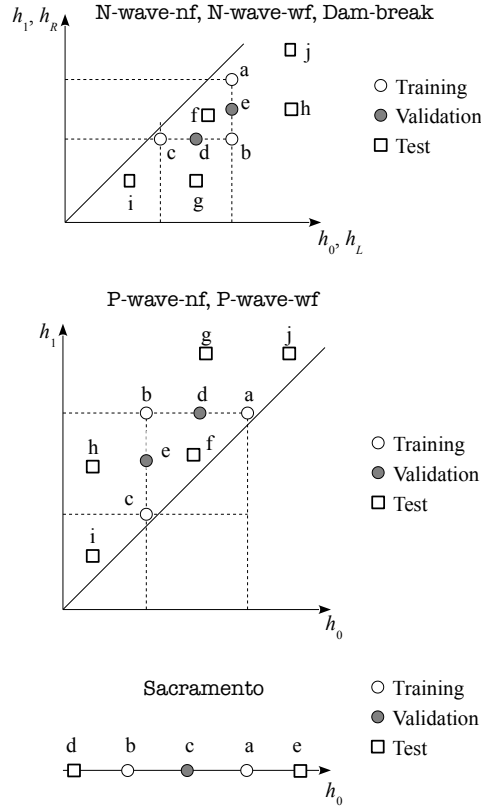


Figure 9: Experiment plan definition sketch for each configuration.

1 Table 2 for a compilation of the total number of time steps available for training, validation and  
2 test). The sampling time step is 10 s in configurations N-wave-nf, N-wave-wf, P-wave-nf and  
3 P-wave-wf and 5 s for Dam-break and Sacramento. For each synthetic urban configuration,  
4 the length of the simulation period may change with the BC and/or IC values so as to ensure  
5 that there is no wave reflection phenomena. The negative wave configurations, N-wave-nf  
6 and N-wave-wf, have a duration of 400 s - 41 time steps - for all BC and/or IC values except  
7 for the “j” one which is set to 260 s - 27 time steps. P-wave-nf has a duration of 300 s - 31  
8 time steps -in call cases except for the BC and/or IC pair of values labelled “g” that has a  
9 time span of 200 s - 21 time steps. P-wave-wf has a duration of 300 s - 31 time steps - in all  
10 cases. Dam-break has a 100 s duration - 21 time steps - for all BC and/or IC values except  
11 the one labelled “j” that has a duration of 80 s - 17 time steps. The field scale simulation has  
12 a duration of 240 s - 49 time steps - except for the IC labelled “d” which spans 480 s - 97 time  
13 steps - to allow the water to reach most areas.

| Configuration | Training | Validation | Test |
|---------------|----------|------------|------|
| N-wave-nf     | 123      | 82         | 191  |
| N-wave-wf     | 123      | 82         | 191  |
| P-wave-nf     | 93       | 62         | 145  |
| P-wave-wf     | 93       | 62         | 155  |
| Dam-break     | 63       | 42         | 101  |
| Sacramento    | 98       | 49         | 146  |

Table 4: Number of time steps available for training, validation and test for each configuration.

## 1 5. Evaluation and comparison of downscaling methods

### 2 5.1. Principal spatial patterns

3 The global downscaling approach described in subsection 3.2 relies on the assumption that  
4 a representative enough basis of spatial patterns  $B$  in (13) can be identified with PCA. Before  
5 applying the global approach systematically, a preliminary analysis of the spatial patterns  
6 uncovered by PCA is presented in order to provide some insights into this approach. To this  
7 end, PCA is applied on the training set, see Table 2, and the first six Principal Components  
8 (PCs) are illustrated for each configuration. As PCs are adimensional, their value is relative  
9 to one another. The spatial patterns are computed for the two risk variables considered, i.e.  
10 the water depth and the norm of the unit discharge, see the discussion in subsection 2.2.

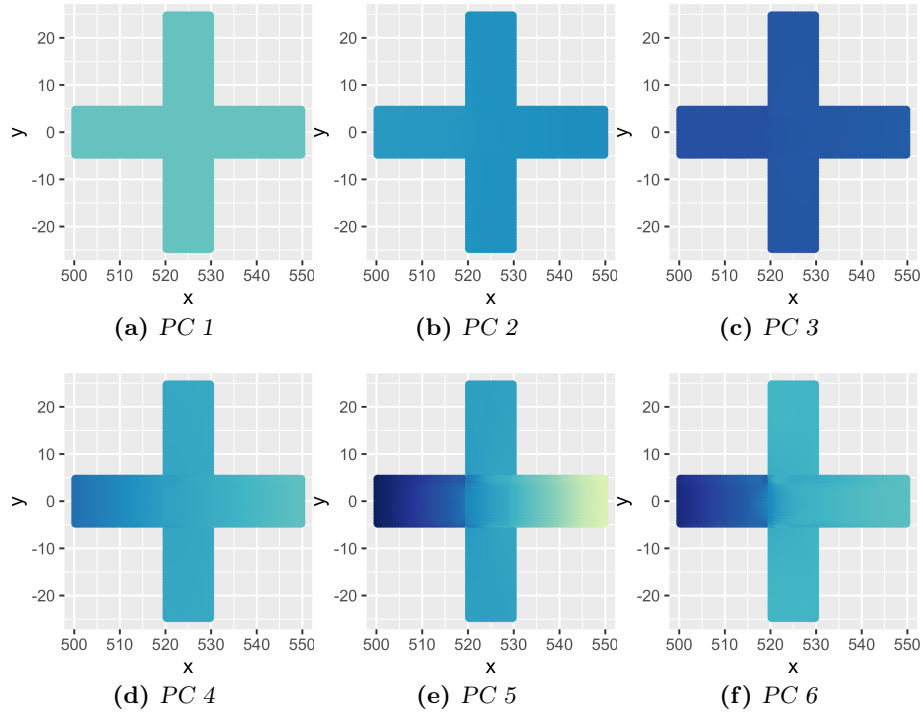
11 The dimension of the high resolution field, i.e. the number of cells in the fine mesh  
12 considered, is  $P = 6912$  for the synthetic urban configurations and  $P = 77\,963$  for the field-  
13 scale test. For the synthetic urban configurations, only the subdomain located in the middle of  
14 the computational domain, with  $x$ -limits [500 m, 550 m], is shown, the other two subdomains  
15 have similar patterns. In addition, for the positive and negative waves, only the configurations  
16 without friction are shown, the ones with friction having similar albeit smoother patterns are  
17 deferred to Appendix A.

18 For **N-wave-nf**, the water depth has spatial patterns oriented along the  $x$ -direction on the  
19 horizontal branch, see Fig. 10. In contrast, the norm of the unit discharge exhibits complex  
20 spatial patterns along the  $y$ -direction on the vertical branches, see Fig. 11. For **P-wave-nf**,  
21 similar differences between the water depth and the norm of the unit discharge spatial patterns  
22 can be observed, see Figs. 12-13, though the patterns are more jagged. Similar remarks hold  
23 for **N-wave-wf** and **P-wave-wf**, see Figs. A.26-A.29. For **Dam-break**, the oblique orientation  
24 of the spatial patterns is visible for both the water depth and the norm of the unit discharge,  
25 see Fig. 14-15. Last, in Fig. 16-17, the spatial patterns of the water depth and the norm of  
26 the unit discharge for **Sacramento** are shown. Although the spatial patterns of the norm of  
27 the unit discharge are sharper than those of the water depth, the general shape, with the  
28 propagation of the water from the breach in the dike located at the top left (see Fig. 7), is  
29 similar for both risk variables.

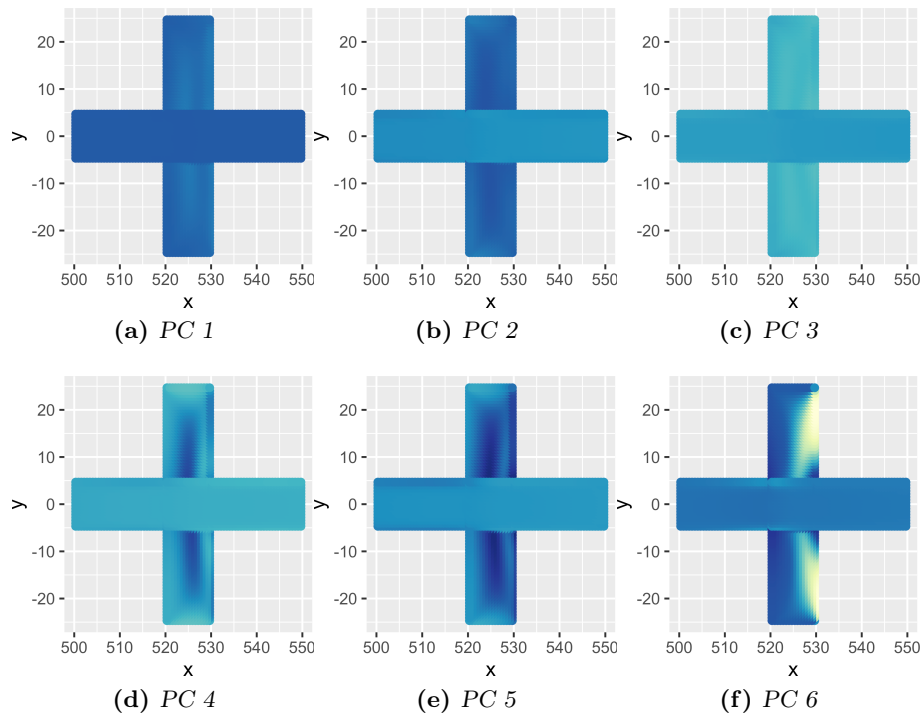
### 30 5.2. Hyper-parameter selection

31 For the five synthetic urban configurations and the field-scale test, the hyper-parameters  
32 selected for the two downscaling approaches described in section 3 and for the two risk variables  
33 considered (water depth and norm of the unit discharge) are provided in Table 5. Several values  
34 are considered for each hyper-parameter so as to span the range of possibilities, starting from  
35 the lowest admissible value up to a value large enough to ensure that the selected value is not  
36 involuntarily bounded. The combination of all the values considered for each hyper-parameter  
37 are evaluated, i.e. the corresponding ANNs are trained, and the best combination, i.e. the  
38 one that yields the lowest validation error, is retained.

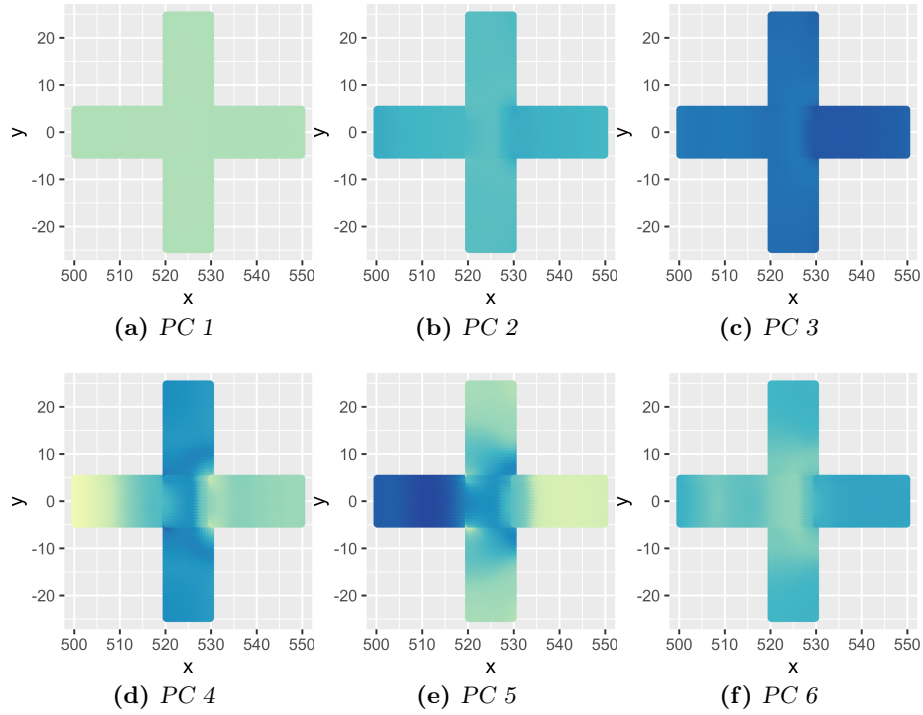
39 As expected, the number of spatial patterns (or equivalently, the number of PCs) selected  
40 is much lower when the risk variable is in a configuration yielding smoother dynamics, see the



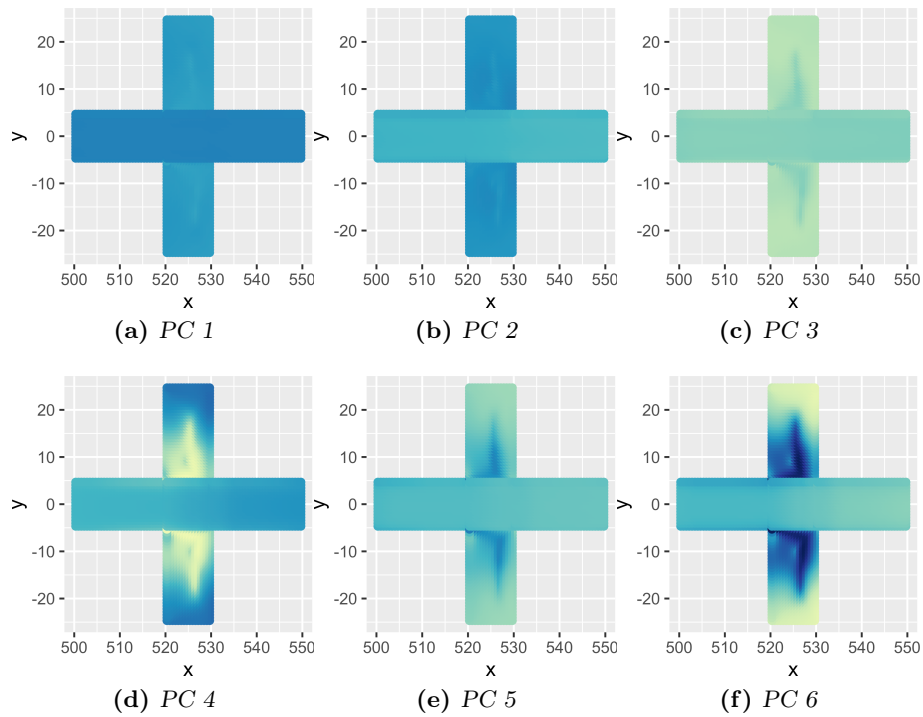
**Figure 10:** Spatial patterns of the water depth for N-wave-nf obtained with PCA (first six PCs) over the subdomain located in the middle of the computational domain. The same adimensional color scale is used for all PCs.



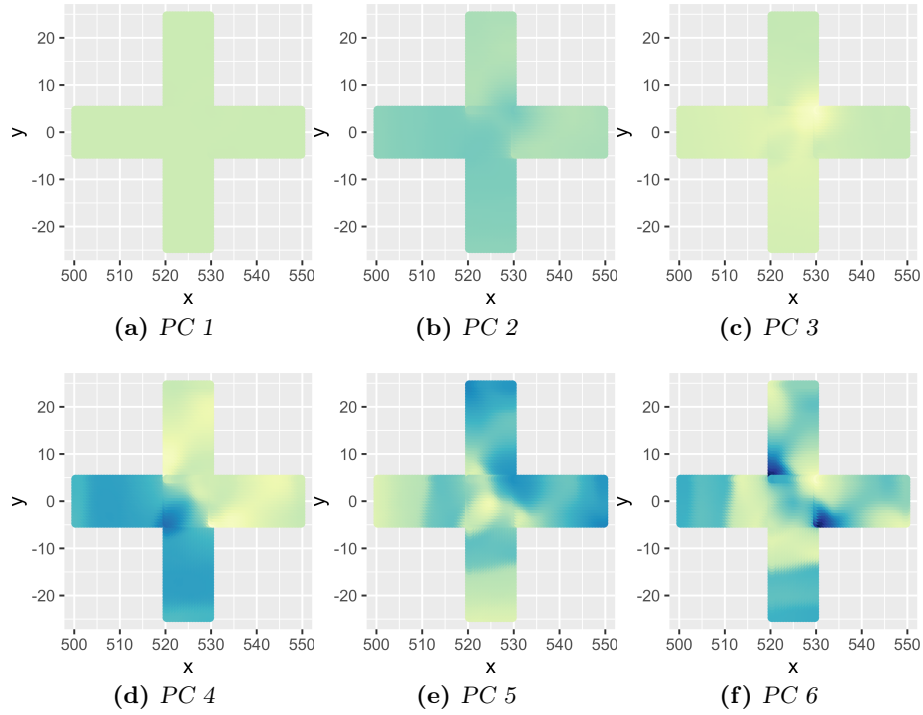
**Figure 11:** Spatial patterns of the norm of the unit discharge for N-wave-nf obtained with PCA (first six PCs) over the subdomain located in the middle of the computational domain. The same adimensional color scale is used for all PCs.



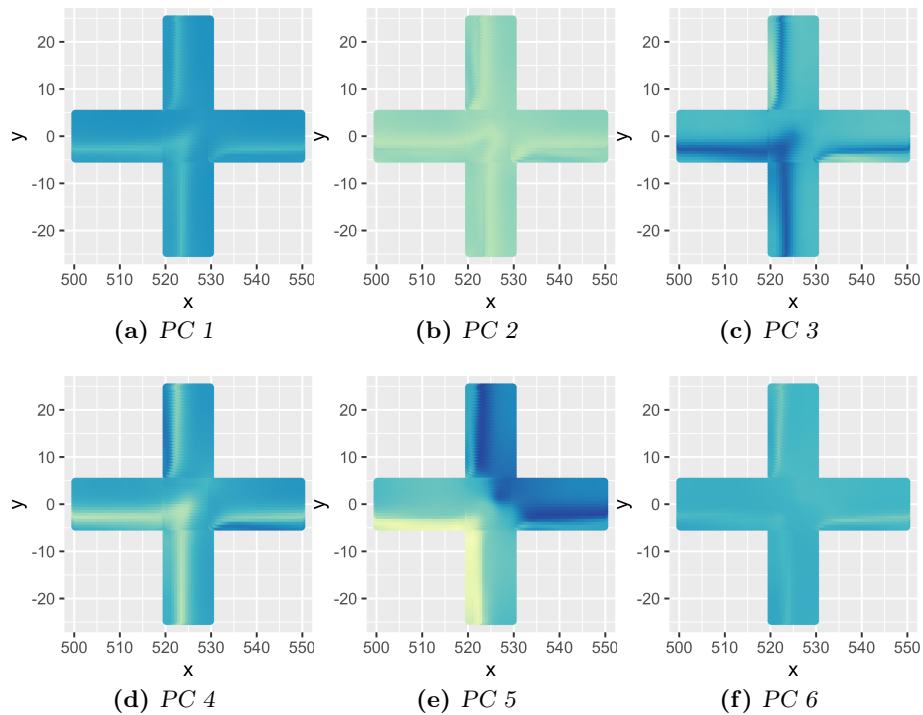
**Figure 12:** Spatial patterns of the water depth for P-wave-nf obtained with PCA (first six PCs) over the subdomain located in the middle of the computational domain. The same adimensional color scale is used for all PCs.



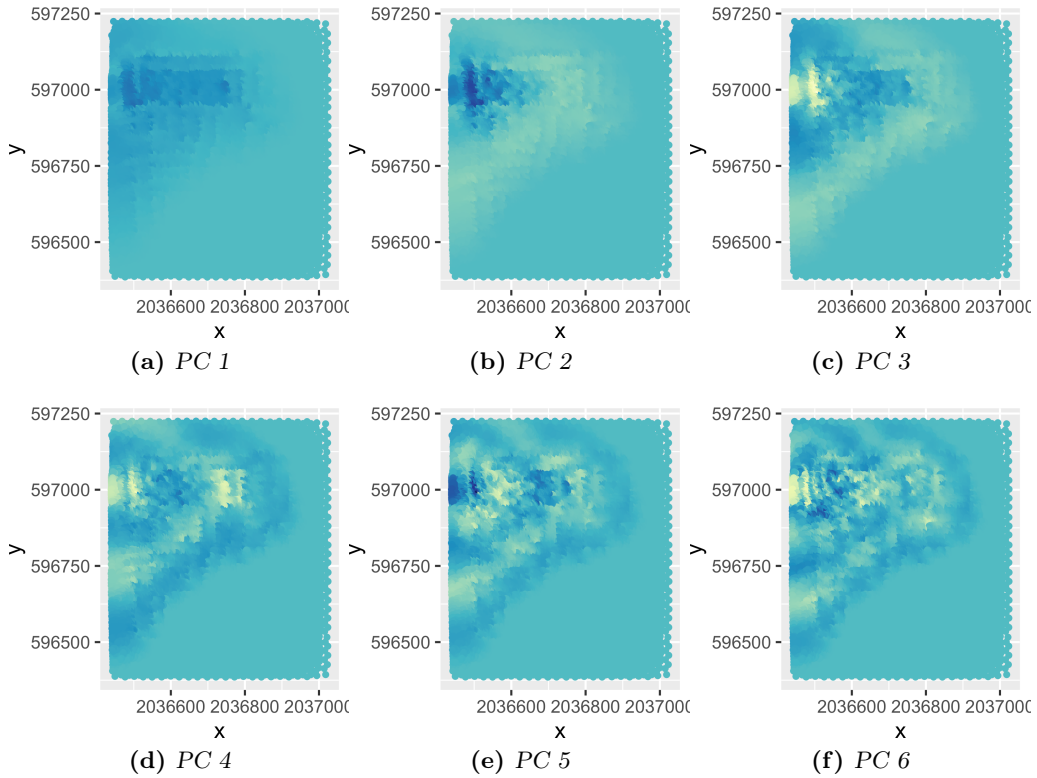
**Figure 13:** Spatial patterns of the norm of the unit discharge for P-wave-nf obtained with PCA (first six PCs) over the subdomain located in the middle of the computational domain. The same adimensional color scale is used for all PCs.



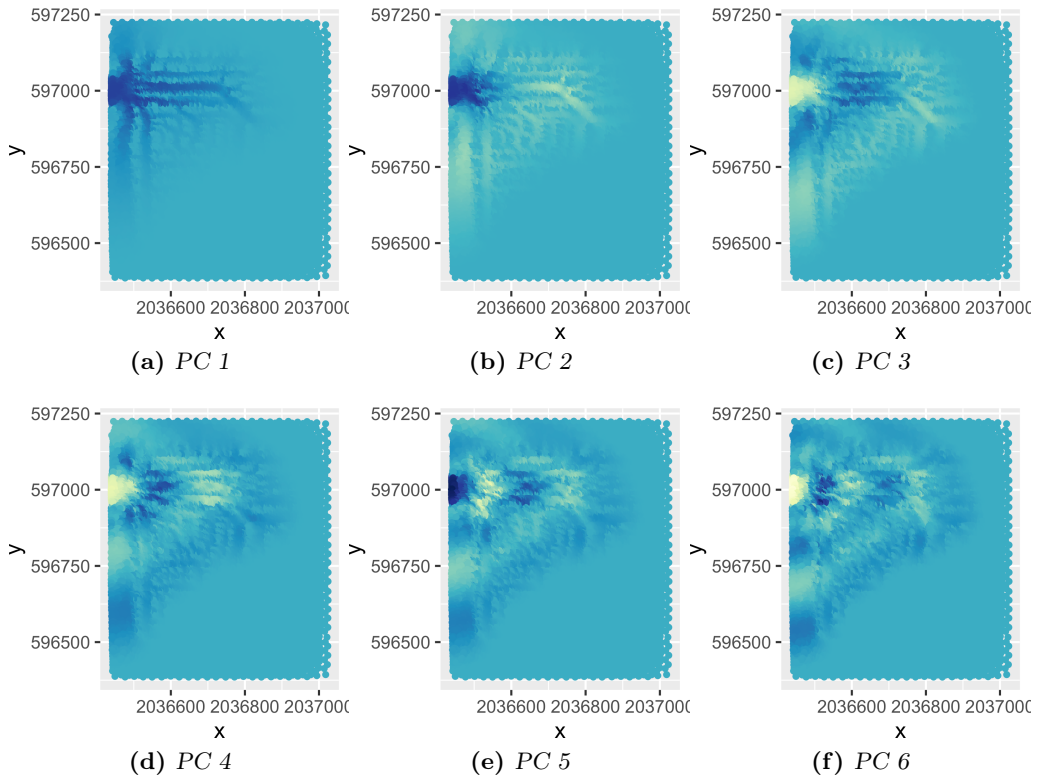
**Figure 14:** Spatial patterns of the water depth for Dam-break obtained with PCA (first six PCs) over the subdomain located in the middle of the computational domain. The same adimensional color scale is used for all PCs.



**Figure 15:** Spatial patterns of the norm of the unit discharge for Dam-break obtained with PCA (first six PCs) over the subdomain located in the middle of the computational domain. The same adimensional color scale is used for all PCs.



**Figure 16:** Spatial patterns of the water depth for Sacramento obtained with PCA (first six PCs) over the subdomain located in the middle of the computational domain. The same adimensional color scale is used for all PCs.



**Figure 17:** Spatial patterns of the norm of the unit discharge for Sacramento obtained with PCA (first six PCs) over the subdomain located in the middle of the computational domain. The same adimensional color scale is used for all PCs.

1  $p$ -column of Table 5. This is the case for the water depth in the negative or positive wave  
 2 configurations, with or without friction. In contrast, the water depth in the **Dam-break** and  
 3 **Sacramento** configurations and the norm of the unit discharge, especially in the **P-wave-nf**  
 4 / **wf** and **Sacramento** configurations, require higher numbers of spatial patterns. The only  
 5 configuration in which the norm of the unit discharge requires less spatial patterns than the  
 6 water depth is the **Dam-break** configuration. The input size and the number of hidden units  
 7 of the ANNs, see the columns  $d$  and  $N_h$  in Table 5, in the local and global approaches are  
 8 similar for **P-wave-nf** / **wf** but otherwise can be very different, see for instance the water  
 9 depth in **N-wave-nf** / **wf**. The number of hidden units of the ANN in the global approach is  
 10 almost always zero, indicating that a linear relationship is sufficient.

| Configuration     | Water depth    |         |                 |       |     | Norm of unit discharge |         |                 |       |     |
|-------------------|----------------|---------|-----------------|-------|-----|------------------------|---------|-----------------|-------|-----|
|                   | Local approach |         | Global approach |       |     | Local approach         |         | Global approach |       |     |
|                   | $d$            | $N_h$   | $d$             | $N_h$ | $p$ | $d$                    | $N_h$   | $d$             | $N_h$ | $p$ |
| <b>N-wave-nf</b>  | 20 (0)         | 12 (16) | 8               | 0     | 5   | 10 (5)                 | 12 (19) | 12              | 0     | 20  |
| <b>N-wave-wf</b>  | 20 (0)         | 12 (16) | 8               | 0     | 5   | 10 (5)                 | 12 (18) | 10              | 0     | 10  |
| <b>P-wave-nf</b>  | 19 (1)         | 1 (4)   | 19              | 0     | 5   | 19 (3)                 | 4 (14)  | 19              | 0     | 40  |
| <b>P-wave-wf</b>  | 16 (3)         | 1 (1)   | 16              | 0     | 5   | 12 (3)                 | 2 (4)   | 15              | 2     | 60  |
| <b>Dam-break</b>  | 8 (10)         | 0 (1)   | 18              | 0     | 40  | 19 (6)                 | 1 (8)   | 8               | 0     | 10  |
| <b>Sacramento</b> | 3 (3)          | 2 (0)   | 57              | 0     | 70  | 3 (12)                 | 1 (1)   | 78              | 0     | 80  |

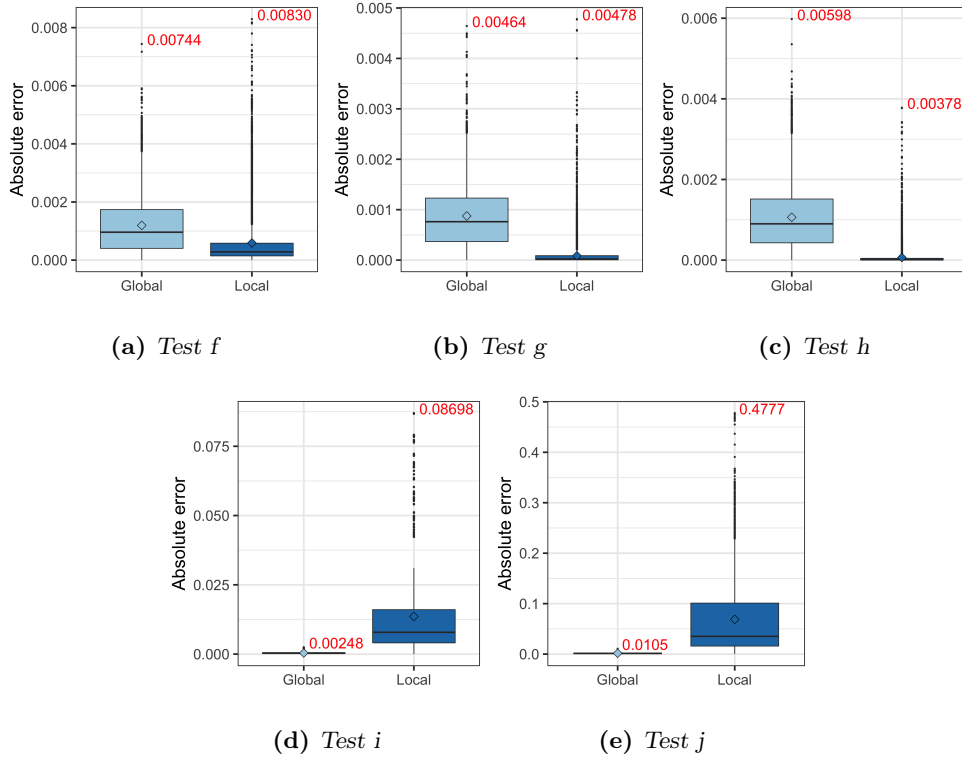
**Table 5:** Selected hyper-parameters for each configuration :  $d$  input dimension,  $N_h$  number of hidden neurons and  $p$  output dimension, see Fig. 2. For the local approach, the median selected value is given with the inter-quartile range in parentheses.

### 11 5.3. Test set comparisons

12 The comparison of the global and local approaches at downscaling the water depth and  
 13 the norm of the unit discharge is carried on the test sets of each configuration, see Table 2,  
 14 with the hyper-parameters selected on the validation sets, see Table 5. To this end, the ANNs  
 15 of the local approach - one per cell - and the ANN of the global approach with the selected  
 16 hyper-parameters are trained anew on a larger data set that merges together the training and  
 17 validation sets. As in the subsection 5.1 on the spatial patterns uncovered by PCA, for the  
 18 positive and negative waves, only configurations without frictions are shown, the ones with  
 19 friction bring similar conclusions and are deferred to Appendix B.

20 For the water depth, the global approach performs generally better, as can be seen from  
 21 the box-plots of the absolute errors for each test set provided in Fig. 18-21. One exception is  
 22 **N-wave-nf**, see Fig. 18 (similarly for **N-wave-wf**, see Fig. B.30), for which the local approach  
 23 performs slightly better for Test f, Test g and Test h but the overall absolute error is small  
 24 ( $< 8 \times 10^{-3}$  m). For Test i and Test j, the global approach performs better and the absolute  
 25 error of the local approach jumps up to  $\approx 0.5$  m for Test j. For **P-wave-nf** shown in Fig. 19  
 26 (similarly for **P-wave-wf**, see Fig. B.31), the local approach performs worst on all test sets,  
 27 especially Test g, Test h, Test i and Test j, with an absolute error up to  $\approx 4$  m, whereas  
 28 the global approach's absolute error is bounded below 0.5 m for Test g and is much lower on  
 29 the other test sets. For **Dam-break**, the global approach outperforms the local approach on  
 30 most test sets although some test sets, such as Test g and Test h, are more challenging for

1 both approaches, see Fig. 20. For **Sacramento**, the global approach also outperforms the local  
 2 approach, especially for Test e, see Fig. 21.



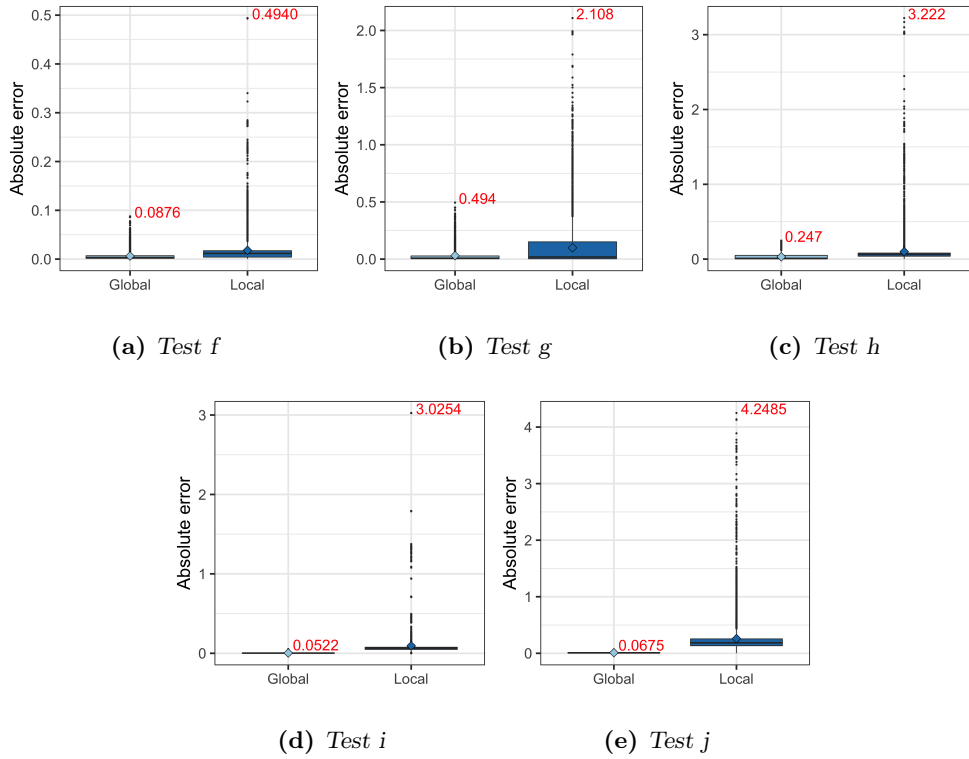
**Figure 18:** Downscaling of the water depth for **N-wave-nf** : box-plots of absolute errors for the global and the local downscaling approaches over the three selected subdomains (375 cells) for each of the five test sets, see Table 4. The maximum error is indicated in red over each box-plot.

3 For the norm of the unit discharge, the global approach performs much better for all con-  
 4 figurations and all test sets, see Fig. 22-25. For **N-wave-nf** in Fig. 22 (similarly for **N-wave-wf**  
 5 in Fig. B.32), the absolute error for the global approach is bounded below  $0.05 \text{ m}^2/\text{s}$ . In  
 6 contrast, the local approach's error exceeds  $12 \text{ m}^2/\text{s}$  for Test j. For **P-wave-nf** in Fig. 23  
 7 (similarly for **P-wave-wf** in Fig. B.33), one can observe that, again, the global approach has  
 8 low absolute errors  $< 0.7 \text{ m}^2/\text{s}$  whereas the local approach's absolute errors are very large,  
 9 especially for Test f, Test g, Test h and Test j. Much like for the water depth, **Dam-break** is  
 10 more challenging for both approaches, see Fig. 24. In particular, the global approach has an  
 11 absolute error of up to  $\approx 6 \text{ m}^2/\text{s}$  on Test h but on the other test sets, the error is below  $\approx$   
 12  $2 \text{ m}^2/\text{s}$  or less. In contrast, the absolute errors of the local approach are very large, greater  
 13 than  $10 \text{ m}^2/\text{s}$  for Test h and Test j. For **Sacramento**, much like for the water depth, the global  
 14 approach outperforms the local approach with greater discrepancy between them for Test e,  
 15 see Fig. 25.

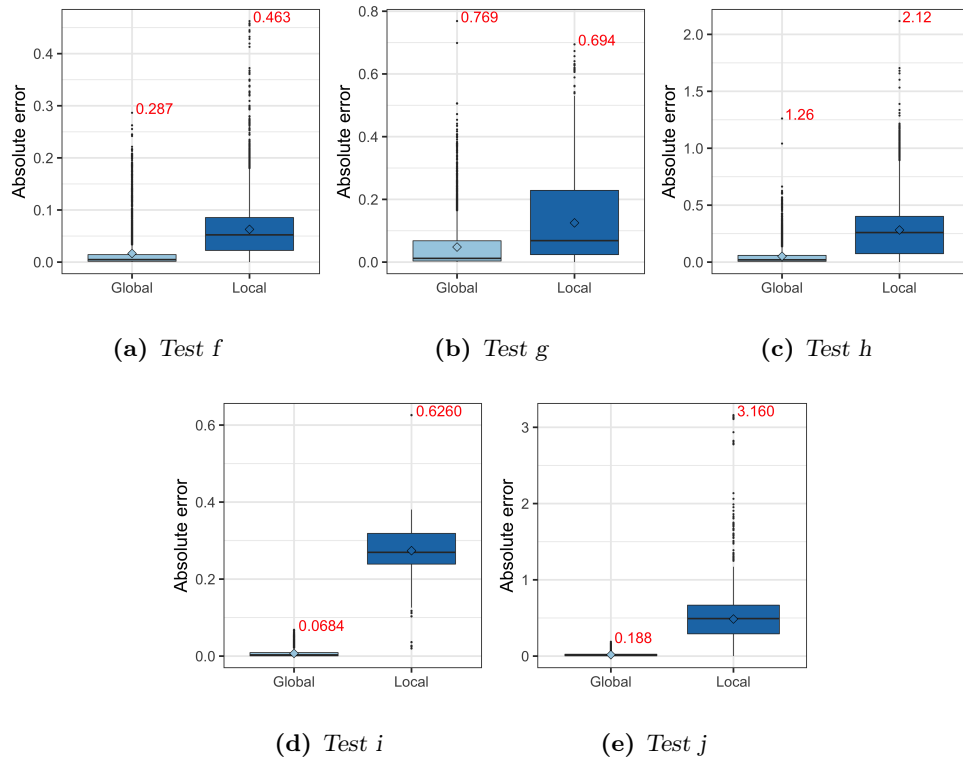
## 16 6. Discussion and conclusion

17 We proposed a statistical model that is capable of downscaling very high dimensional fields  
 18 such as the ones simulated by refined shallow water models, see subsection 3.2 and Fig. 1b

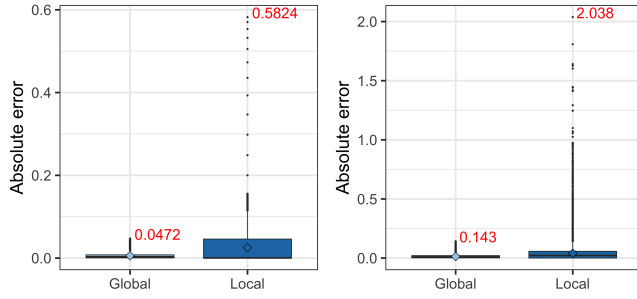




**Figure 19:** Downscaling of the water depth for P-wave-nf : box-plots of absolute errors for the global and the local downscaling approaches over the three selected subdomains (375 cells) for each of the five test sets, see Table 4. The maximum error is indicated in red over each box-plot.



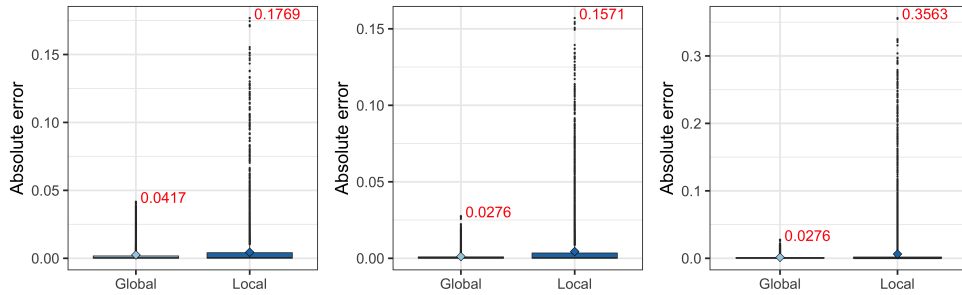
**Figure 20:** Downscaling of the water depth for Dam-break : box-plots of absolute errors for the global and the local downscaling approaches over the three selected subdomains (375 cells) for each of the five test sets, see Table 4. The maximum error is indicated in red over each box-plot.



(a) Test d

(b) Test e

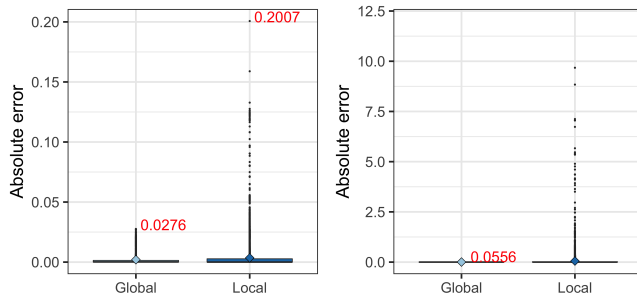
**Figure 21:** Downscaling of the water depth for Sacramento : box-plots of absolute errors for the global and the local downscaling approaches over the selected subregion (575 cells) for each of the five test sets, see Table 4. The maximum error is indicated in red over each box-plot.



(a) Test f

(b) Test g

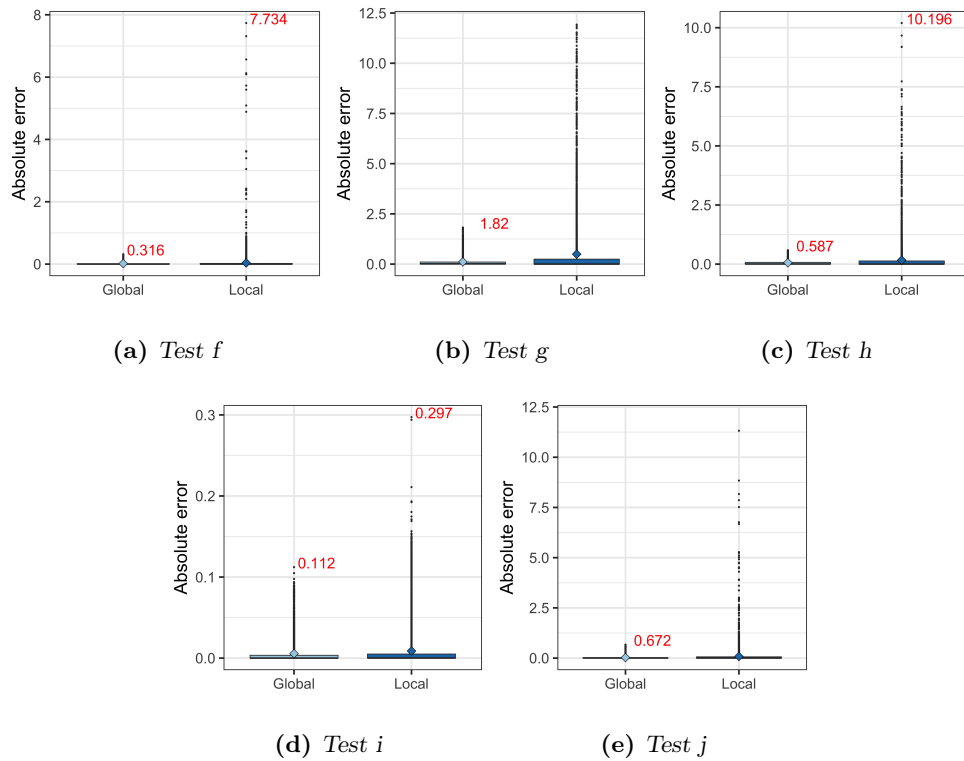
(c) Test h



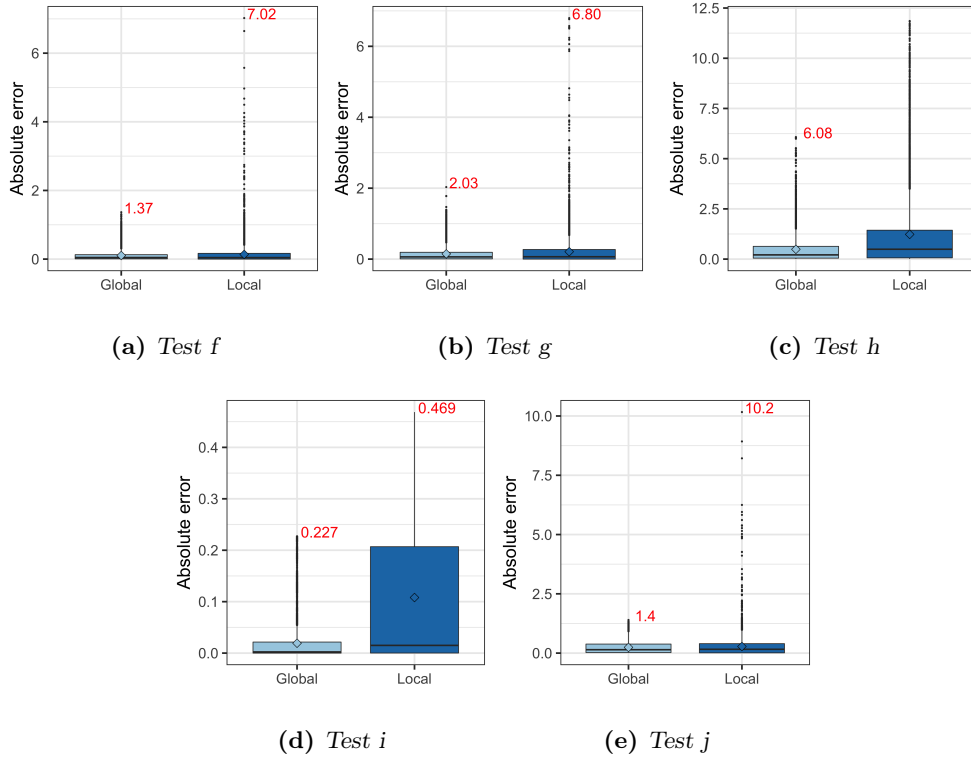
(d) Test i

(e) Test j

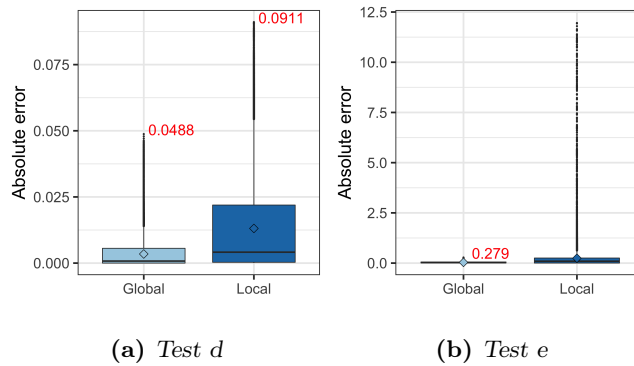
**Figure 22:** Downscaling of the norm of the unit discharge for N-wave-nf : box-plots of absolute errors for the global and the local downscaling approaches over the three selected subdomains (375 cells) for each of the five test sets, see Table 4. The maximum error is indicated in red over each box-plot. The scale is capped at 12.



**Figure 23:** Downscaling of the norm of the unit discharge for P-wave-nf : box-plots of absolute errors for the global and the local downscaling approaches over the three selected subdomains (375 cells) for each of the five test sets, see Table 4. The maximum error is indicated in red over each box-plot. The scale is capped at 12.



**Figure 24:** Downscaling of the norm of the unit discharge for *Dam-break* : box-plots of absolute errors for the global and the local downscaling approaches over the three selected subdomains (375 cells) for each of the five test sets, see Table 4. The maximum error is indicated in red over each box-plot. The scale is capped at 12.



**Figure 25:** Downscaling of the norm of the unit discharge for *Sacramento* : box-plots of absolute errors for the global and the local downscaling approaches over the three selected subdomains (375 cells) for each of the five test sets, see Table 4. The maximum error is indicated in red over each box-plot. The scale is capped at 12.

1 that summarizes the downscaling model. A key step of this downscaling approach consists in  
2 decomposing the high dimensional field into a linear combination of spatial patterns. PCA is  
3 often used to obtain spatial patterns from fields of climatic variables in order to infer weather  
4 types, i.e. recurring patterns that can be found, for instance, in large scale atmospheric  
5 circulation [46]. From the simulated fields of flow variables for urban flood risk assessment,  
6 PCA yielded spatial patterns that are visually interpretable with respect to expert knowledge  
7 for each configuration and for the two risk variables considered - water depth and norm of the  
8 unit discharge, see Figs. 10-17 and Figs. A.26-A.29.

9 The coefficients of the linear combination of spatial patterns can be thought of as a pro-  
10 jection of the high dimensional field onto a low dimensional feature space. In the weather  
11 type approach mentioned above, clustering can be performed on the features obtained from  
12 PCA to classify each time steps, e.g. days, into weather types. In contrast, in the proposed  
13 global downscaling approach, these features are taken as the multivariate dependent variable  
14 in a regression model, a feed-forward neural network with a direct linear connection as in  
15 Fig. 2b. Model selection, see Table 5, showed that, as was anticipated, more spatial patterns,  
16 i.e. a larger dimension of the feature space, are needed to reconstruct the spatial field of more  
17 turbulent risk variables. With no hidden units selected in most cases for the ANN, the global  
18 approach is in fact a large dimensional multivariate linear regression. The estimation of the  
19 model is carried out by combining three steps : (1) PCA of the low resolution field, (2) PCA  
20 of the high resolution field and (3) regression between the feature space of the low and high  
21 resolution fields. Despite being a linear model, the estimation could not be achieved with a  
22 single direct estimation step, as is the case with conventional linear regression, owing to the  
23 large dimension of the dependent variable.

24 We compared the global statistical downscaling approach proposed in this work with a  
25 local approach that is in fact a set of downscaling models, one for each cell of the mesh on  
26 which the high resolution risk variable is simulated, see subsection 3.1 and Fig. 1a. A potential  
27 alternative to this local approach would be to consider a single ANN that would be able to  
28 downscale all the cells of the mesh, one at a time, by including in its input specific information  
29 from each cell. For instance in [13], a climate variable simulated on a 25 km resolution grid  
30 by a Regional Climate Model (RCM) constrained by a GCM on a lower resolution grid of  
31  $1.89^\circ$  is downscaled with a single ANN, one RCM cell at a time. Among the ANN input,  
32 there is information from the large scale variable at the four GCM grid cells surrounding  
33 the RCM grid cell of interest. By using information that changes with each RCM cell, the  
34 ANN is able to learn a relationship that can vary from cell to cell. Such an approach was  
35 considered initially in the shallow water models' context but was put aside. Indeed, as the  
36 number of cells within each subdomain is very high, the question of which spatial information  
37 - geographical coordinates not being sufficient - would be useful to help discriminate each cell  
38 has no straightforward answer.

39 The results from section 5 showed that the proposed global approach yields good overall  
40 performance and outperforms in most cases the local approach with an equivalent performance  
41 only in a few cases. Nevertheless, absolute errors on test sets can be unacceptably high, e.g.

1 almost 0.5 m for the water depth in **P-wave-nf**, see Fig. 19b, or about 2 m<sup>2</sup>/s for the norm  
2 of the unit discharge in **Dam-break**, see Fig. 24b. Further work is needed to understand when  
3 and why the global downscaling approach is successful and how to bring improvements when  
4 it performs poorly. An interesting avenue of research would be to investigate the representa-  
5 tiveness of the spatial pattern basis. Does the training set contain informative enough data  
6 to uncover the spatial pattern basis ? In other words, does the training set include all the  
7 spatial patterns that are present in the validation and test sets ? Another avenue would be  
8 to consider techniques other than PCA to deduce the spatial patterns such as frames [17].  
9 Besides, stochasticity could be introduced in the downscaling methods which would be helpful  
10 to account for uncertainties in the estimation. For the local approach, it suffices to see the  
11 outputs of the ANN as the parameters of a given probability distribution [10, 12]. For the  
12 global approach, the stochastic version of PCA could be implemented [7].

13 Other perspectives for this work are as follows. The hydraulic simulations reported involve  
14 a flat topography. The performance of the downscaling approaches in the case of a variable  
15 topography should be explored. In the case of a spatially variable bottom elevation, the free  
16 surface elevation is often smoother than the water depth. Whether the surface elevation is  
17 easier to downscale than the water depth should be assessed. In addition, imperfect upscaling  
18 should be tested as nonlocal effects are to be expected. As mentioned in subsection 2.2, the  
19 water depth and the norm of the unit discharge are not the only possible variables for flood  
20 risk assessment. The possibility of downscaling additional variables such as the specific force  
21 per unit width and the hydraulic head should also be investigated. This might induce an  
22 increased level of complexity compared to the downscaling of the water depth and the unit  
23 discharge because the specific force and the hydraulic head are not conserved variables. Last,  
24 in some cases, only the maximum of a given flow variable within a given area might be needed  
25 for risk assessment. In such cases, downscaling techniques developed within the theory of  
26 extreme values could be useful [5].

- [1] Abt, S.R., Wittler, R.J, Taylor, A, & Love, DJ. 1989. Human Stability in a High Flood Hazard Zone. *Water Resources Bulletin*, **25**, 881–890.
- [2] Ayar, P. V., Vrac, M., Bastin, S., Carreau, J., Déqué, M., & Gallardo, C. 2016. Inter-comparison of statistical and dynamical downscaling models under the EURO-and MED-CORDEX initiative framework: present climate evaluations. *Climate Dynamics*, **46**(3-4), 1301–1329.
- [3] Bates, P.D. 2000. Development and testing of a sub-grid scale model for moving boundary hydrodynamic problems in shallow water. *Hydrol Processes*, **14**, 2073–2088.
- [4] Bates, P.D., & De Roo, A.P.J. 2000. A simple raster-based model for flood inundation simulation. *Journal of Hydrology*, **236**, 54–77.
- [5] Bechler, A., Vrac, M., & Bel, L. 2015. A spatial hybrid approach for downscaling of extreme precipitation fields. *Journal of Geophysical Research: Atmospheres*, **120**(10), 4534–4550.
- [6] Bernardini, G., Postacchii, M., Quagliarini, E., Brocchini, M., Cianca, C., & D’Orazio. 2017. A preliminary combined simulation tool for the risk assessment of pedestrians’ flood-induced evacuation. *Environmental Modelling & Software*, **96**, 14–29.
- [7] Bishop, C. M. 2011. *Pattern Recognition and Machine Learning*. Information Science and Statistics. Springer.
- [8] Blanco-Vogt, A., & Schanze, J. 2014. Assessment of the physical flood susceptibility of buildings on a large scale – conceptual and methodological frameworks. *Nat. Hazards Earth Syst. Sci.*, **14**, 2105–2117.
- [9] Bruwier, M., Archambeau, P., Erpicum, S., Pirotton, M., & Dewals, B. 2017. Shallow-water models with anisotropic porosity and merging for flood modelling on Cartesian grids. *Journal of Hydrology*, **554**, 693–709.
- [10] Cannon, A. J. 2012. Neural networks for probabilistic environmental prediction: Conditional Density Estimation Network Creation and Evaluation (CaDENCE) in R. *Computers & Geosciences*, **41**, 126–135.
- [11] Cannon, A. J. 2018. Multivariate quantile mapping bias correction: an N-dimensional probability density function transform for climate model simulations of multiple variables. *Climate dynamics*, **50**(1-2), 31–49.
- [12] Carreau, J., & Vrac, M. 2011. Stochastic downscaling of precipitation with neural network conditional mixture models. *Water Resources Research*, **47**(10).
- [13] Chadwick, R., Coppola, E., & Giorgi, F. 2011. An artificial neural network technique for downscaling GCM outputs to RCM spatial scale. *Nonlinear Processes in Geophysics*, **18**(6).
- [14] Chanson, H., & Brown, R. 2015. Discussion on “New criterion for the stability of a human body in floodwaters” by Xia et al. (2014). *Journal of Hydraulic Research*, **53**, 540–542.
- [15] Chanson, H., Brown, R., & McIntosh, D. 2014. Human body stability in floodwaters: the 2011 flood in Brisbane CBD. In: Chanson, H., & Toombes, L. (eds), *Proceedings of the 5th International Symposium on Hydraulic Structures: Engineering Challenges and Extremes*. The University of Queensland, Brisbane.

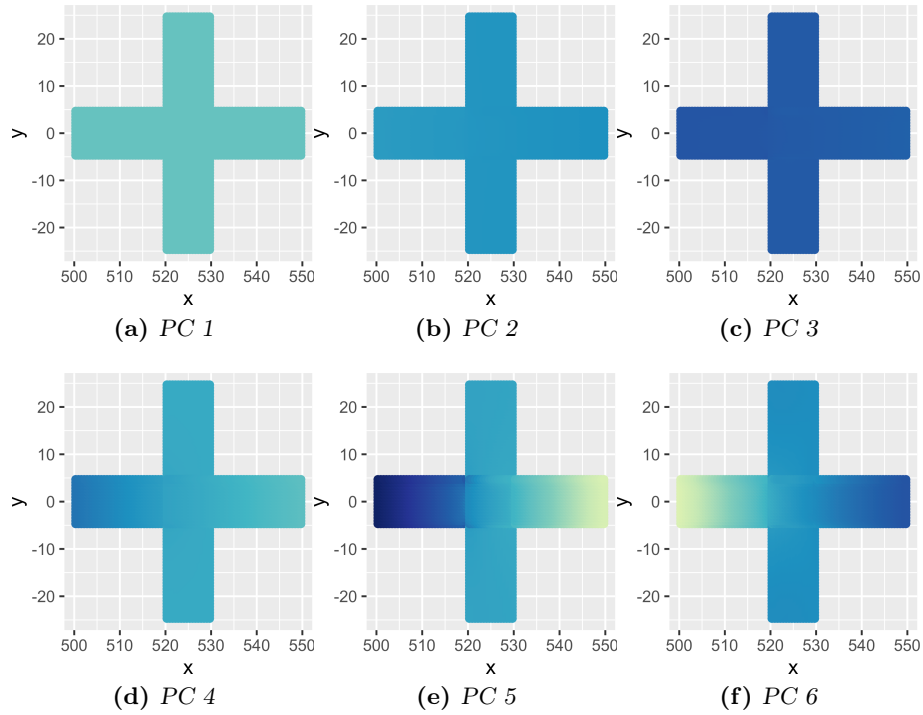
- [16] Chen, A., Evans, B., Djordjevic, S., & Savic, D.A. 2012. A coarse-grid approach to represent building blockage effects in 2D urban flood modelling. *Journal of Hydrology*, **426-427**, 1–16.
- [17] Christensen, O. 2008. *Frames and bases: An introductory course*. Springer Science & Business Media.
- [18] Cox, R.J., Shand, T.D., & Blacka, M.J. 2010. *Australian Rainfall and Runoff Revision Project 10: Appropriate Safety Criteria for People*. Tech. rept. Report P10/S1/006. AR&R. ISBN 978-085825-9454.
- [19] Defina, A. 2000. Two-dimensional shallow flow equations for partially dry areas. *Water Resour Res*, **36**, 3251–3264.
- [20] Farmer, C.L. 2002. Upscaling: a review. *International Journal for Numerical Methods in Fluids*, **40**, 63–78.
- [21] Foster, D.N., & Cox, R.J. 1973. *Stability of Children on Roads Used as Floodways*. Tech. rept. 73/13. Water Research Laboratory, The University of New South Wales, Manly Vale, NSW, Australia.
- [22] Guinot, V. 2012. Multiple porosity shallow water models for macroscopic modelling of urban floods. *Advances in Water Resources*, **37**, 40–72.
- [23] Guinot, V. 2017. A critical assessment of flux and source term closures in shallow water models with porosity for urban flood simulations. *Advances in Water Resources*, **109**, 133–157.
- [24] Guinot, V., & Soares-Frazão, S. 2006. Flux and source term discretization in two-dimensional shallow water models with porosity on unstructured grids. *International Journal for Numerical Methods in Fluids*, **50**, 309–345.
- [25] Guinot, V., B.F., Sanders, & J.E., Schubert. 2017. Dual integral porosity shallow water model for urban flood modelling. *Advances in Water Resources*, **103**, 16–31.
- [26] Guinot, V., C., Delenne, & Soares-Frazão, S. 2018. Urban dambreak experiments - River-Flow paper. In: *RiverFlow 2018 international Conference*.
- [27] Hervouët, J.M., Samie, R., & Moreau, B. 2000. Modelling urban areas in dam-break floodwave numerical simulations. In: *Proceedings of the international seminar and workshop on rescue actions based on dambreak flow analysis, Seinäjoki, Finland, 1–6 October 2000*.
- [28] Hewitson, B. C., & Crane, R. G. 1996. Climate downscaling: techniques and application. *Climate Research*, **7**(2), 85–95.
- [29] Ishigaki, T., Kawanaka, R., Onishi, Y., Shimada, H., Toda, K., & Baba, Y. 2009. *Assessment of Safety on Evacuating Route During Underground Flooding*. Springer, Berlin, Heidelberg. Pages 141–146.
- [30] Jongman, B., Kreibich, H., Apel, H., Barredo, J.I., Bates, P.D., Feyen, I., Gericke, A., aned Neal, J., Aerts, J.C.J.H., & Ward, P.J. 2012. Comparative flood damage model assessment: towards a European approach. *Nat. Hazards Earth Syst. Sci.*, **12**, 3733–3752.
- [31] Jonkman, S.N., & Penning-Rowsell, E. 2008. Human Instability in Flood Flows. *Journal of the American Water Resources Association*, **44**, 1–11.



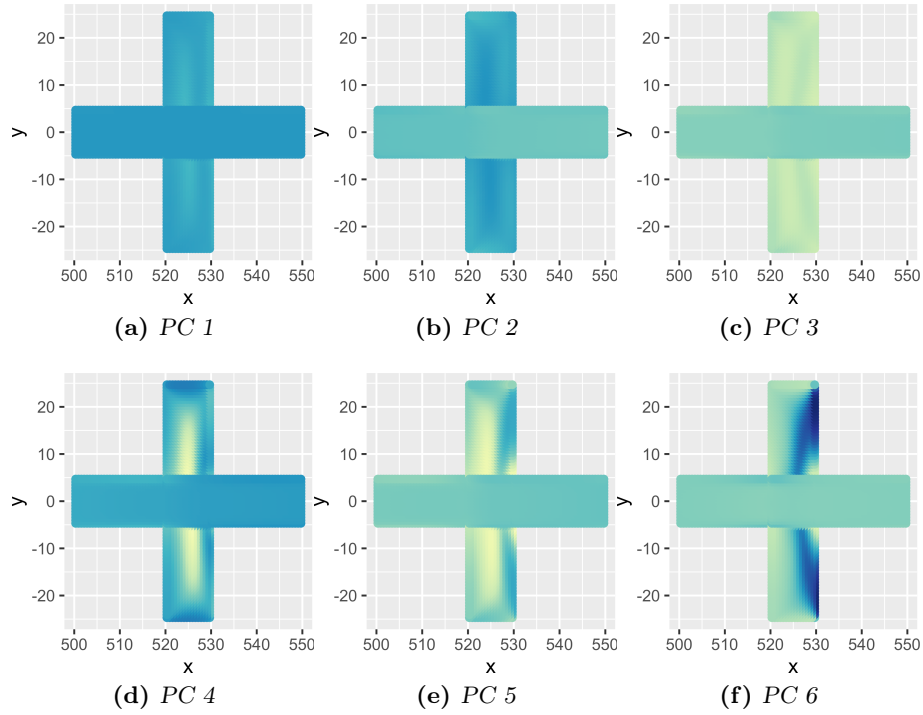
- [32] Karvonen, R.A., Hepojoki, H.K., Huhta, H.K., & Louhio, A. 2000. *The Use Of Physical Models In Dam-Break Flood Analysis, Development of Rescue Actions Based on Dam-Break Flood Analysis (RESCDAM)*. Tech. rept. Helsinki University of Technology, Finnish Environment Institute.
- [33] Kim, B., Sanders, B.F., Famiglietti, J.S., & Guinot, V. 2015. Urban flood modeling with porous shallow-water equations: A case study of model errors in the presence of anisotropic porosity. *Journal of Hydrology*, **523**, 680–692.
- [34] Matsuo, K., Natainia, L., & Yamada, F. 2011. Flood and evacuation simulations for urban flooding. *Pages 391–398 of: Chavoschian, A., & Takeuchi, K. (eds), 5th International Conference on Flood Management*.
- [35] Merz, B., Kreibich, H., Tieken, A., & Schmidtke, R. 2004. Estimation uncertainty of direct monetary flood damage to buildings. *Natural Hazards and Earth System Sciences*, **4**, 153–163.
- [36] Merz, B., Kreibich, H., Schwarze, R., & Thielen, A. 2010. Assessment of economic flood damage. *Nat. Hazards Earth Syst. Sci.*, **10**, 1697–1724.
- [37] Rumelhart, D. E., Hinton, G. E., & Williams, R. J. 1988. Learning representations by back-propagating errors. *Cognitive modeling*, **5**, 3.
- [38] Sanders, B.F., Schubert, J.E., & Gallegos, H.A. 2008. Integral formulation of shallow water models with anisotropic porosity for urban flood modelling. *Journal of Hydrology*, **362**, 19–38.
- [39] Schubert, J.E., Burns, M.J., Fletcher, T.D., & Sanders, B.F. 2017. A framework for the case-specific assessment of Green Infrastructure in mitigating urban flood hazards. *Advances in Water Resources*, **108**, 55–68.
- [40] Seifert, I., Kreibich, H., Merz, B., & Thielen, A.H. 2010. Application and validation of FLEMOcs - a flood-loss estimation model for the commercial sector. *Hydrological Sciences Journal*, **55**, 1315–1324.
- [41] Takahashi, S., Endoh, K., & Muro, Z-I. 1992. *Experimental Study on People's Safety against Overtopping Waves on Breakwaters*. Tech. rept. Report on the Port and Harbour Institute.
- [42] Vrac, M., & Friederichs, P. 2015. Multivariable - intervariable, spatial and temporal - bias correction. *Journal of Climate*, **28**(1), 218–237.
- [43] Wagenaar, D., de Jong, J., & Bouwer, L.W. 2017. Multi-variable flood damage modelling with limited data using supervised learning approaches. *Nat. Hazards Earth Syst. Sci.*, **17**, 1683–1696.
- [44] Wagenaar, D.J., de Bruijn, K.M., Bouwer, & L.M., de Moel, H. 2016. Uncertainty in flood damage estimates and its potential effect on investment decisions. *Nat. Hazards Earth Syst. Sci.*, **16**, 1–14.
- [45] Xia, J., Falconer, R.A., Wang, Y., & Xiao, X. 2014. New Criterion for the Stability of a Human Body in Floodwaters. *Journal of Hydraulic Research*, **52**, 93–104.
- [46] Yiou, P., & Nogaj, M. 2004. Extreme climatic events and weather regimes over the North Atlantic : When and where ? *Geophysical Research Letters*, **31**(7).

- [47] Özgen, I., Zhao, J., Liang, D., & Hinkelmann, R. 2016. Urban flood modeling using shallow water equations with depth-dependent anisotropic porosity. *Journal of Hydrology*, **541**, 1165–1184.

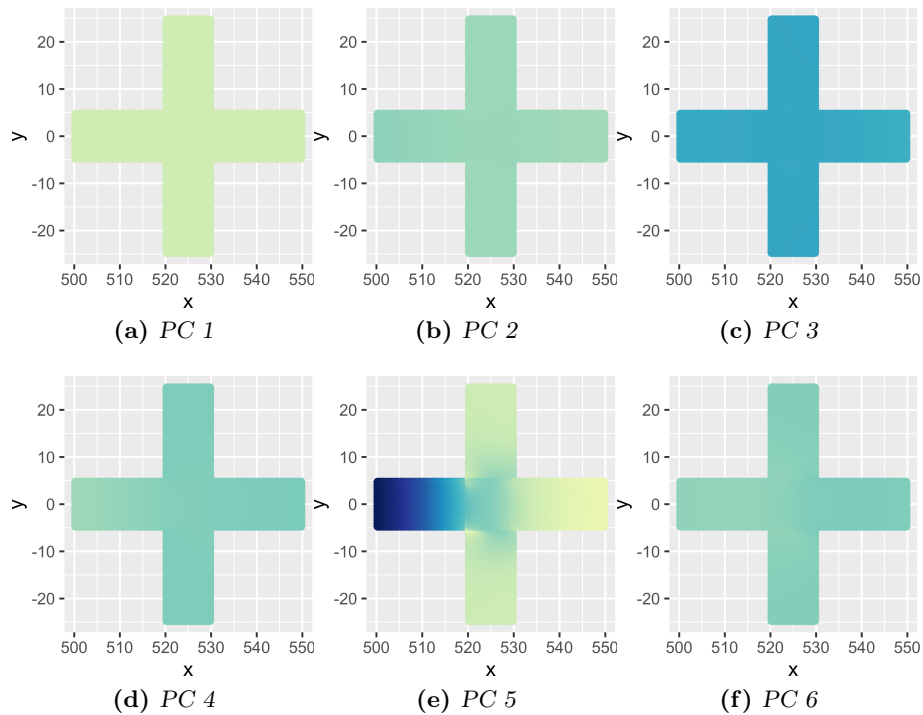
## Appendix A. Principal spatial patterns



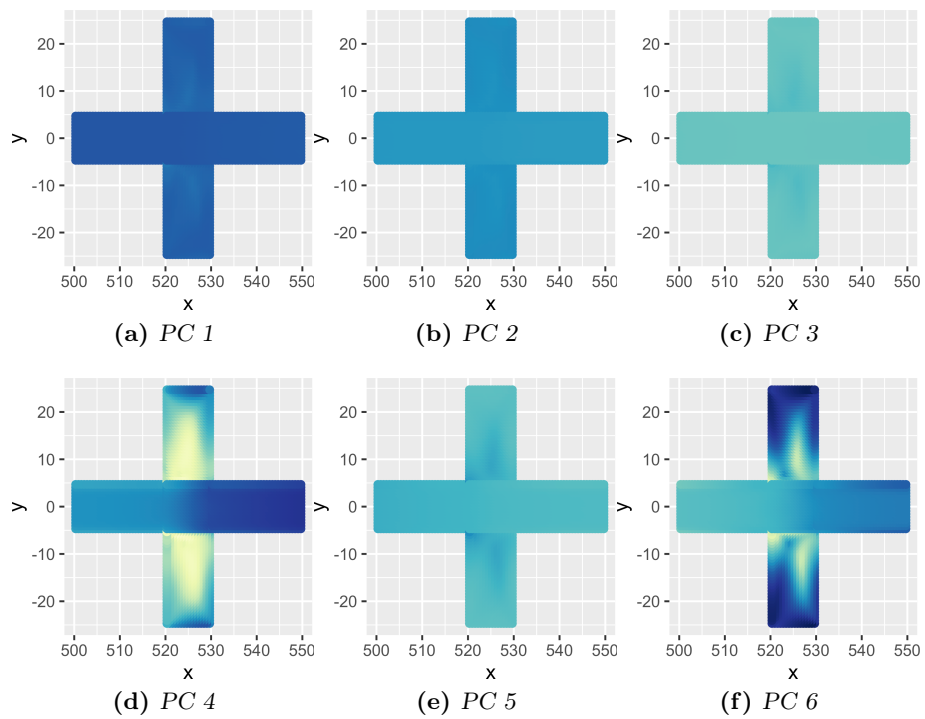
**Figure A.26:** Spatial patterns of the water depth for N-wave-wf obtained with PCA (first six PCs) over the subdomain located in the middle of the computational domain. The same adimensional color scale is used for all PCs.



**Figure A.27:** Spatial patterns of the norm of the unit discharge for N-wave-wf obtained with PCA (first six PCs) over the subdomain located in the middle of the computational domain. The same adimensional color scale is used for all PCs.

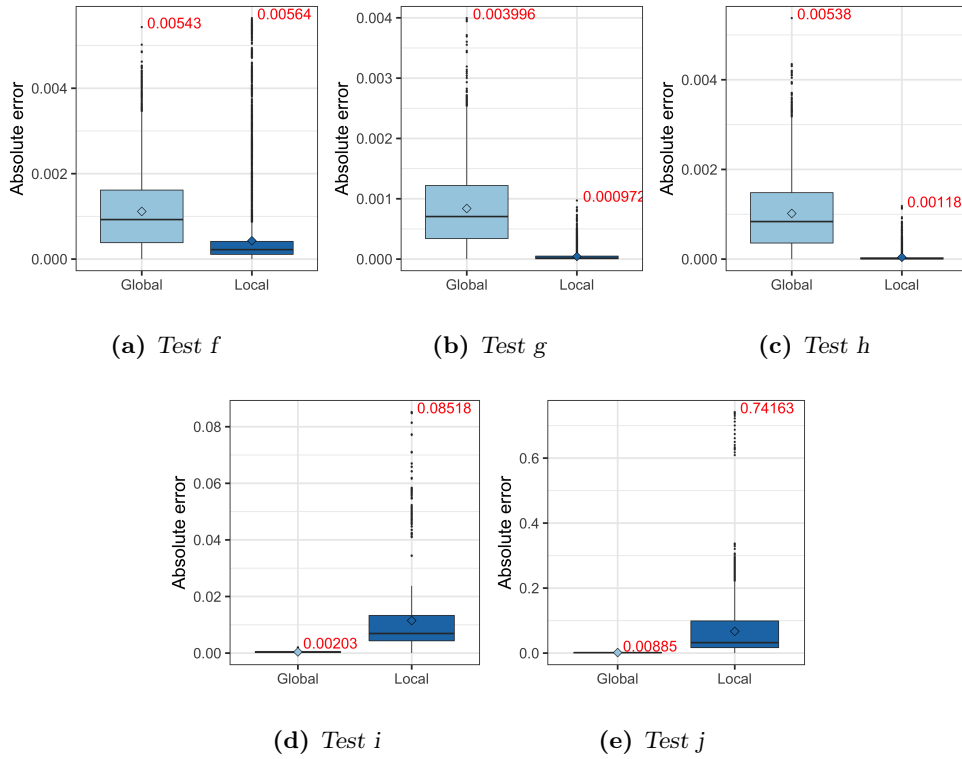


**Figure A.28:** Spatial patterns of the water depth for P-wave-wf obtained with PCA (first six PCs) over the subdomain located in the middle of the computational domain. The same adimensional color scale is used for all PCs.

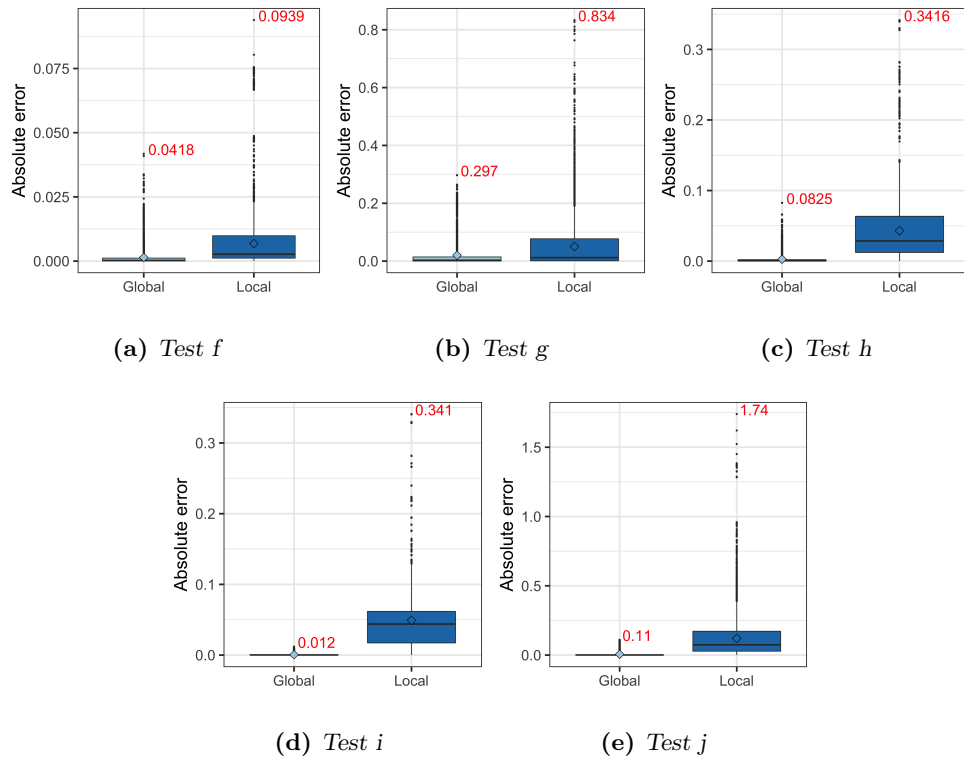


**Figure A.29:** Spatial patterns of the norm of the unit discharge for P-wave-wf obtained with PCA (first six PCs) over the subdomain located in the middle of the computational domain. The same adimensional color scale is used for all PCs.

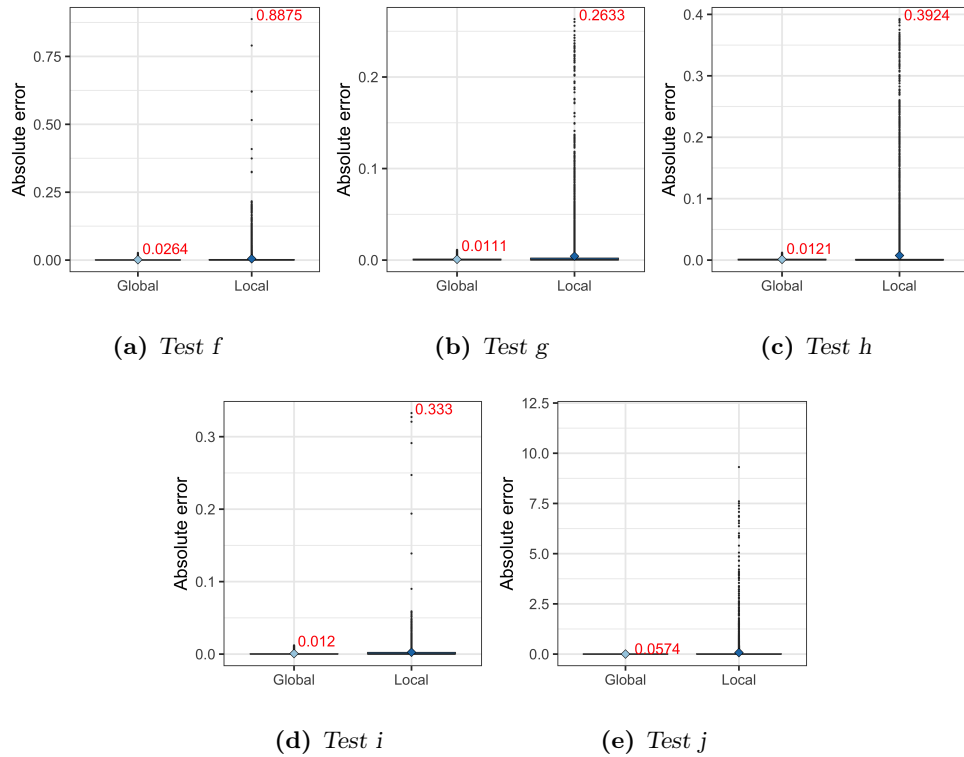
## Appendix B. Evaluation and comparison of downscaling methods



**Figure B.30:** Downscaling of the water depth for N-wave-wf : box-plots of absolute errors for the global and the local downscaling approaches over the three selected subdomains (375 cells) for each of the five test sets, see Table 4. The maximum error is indicated in red over each box-plot.

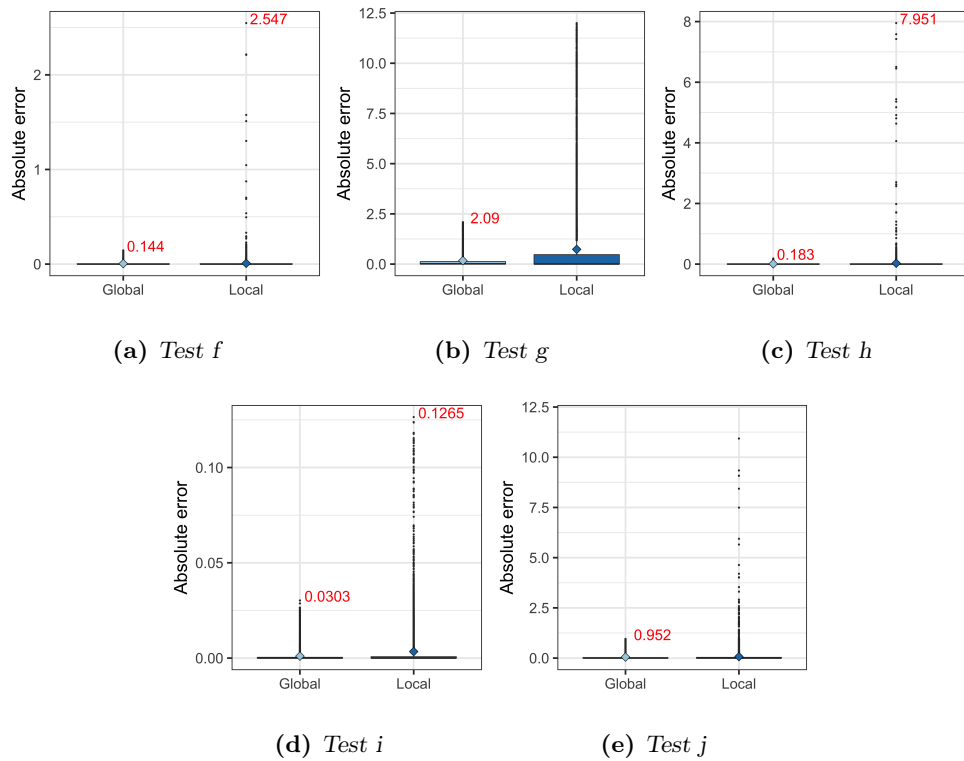


**Figure B.31:** Downscaling of the water depth for P-wave-wf : box-plots of absolute errors for the global and the local downscaling approaches over the three selected subdomains (375 cells) for each of the five test sets, see Table 4. The maximum error is indicated in red over each box-plot.



**Figure B.32:** Downscaling of the norm of the unit discharge for N-wave-wf : box-plots of absolute errors for the global and the local downscaling approaches over the three selected subdomains (375 cells) for each of the five test sets, see Table 4. The maximum error is indicated in red over each box-plot. The scale is capped at 12.





**Figure B.33:** Downscaling of the norm of the unit discharge for P-wave-wf : box-plots of absolute errors for the global and the local downscaling approaches over the three selected subdomains (375 cells) for each of the five test sets, see Table 4. The maximum error is indicated in red over each box-plot. The scale is capped at 12.