



**HAL**  
open science

# Argumentation Frameworks with Recursive Attacks and Evidence-Based Supports

Claudette Cayrol, Jorge Fandinno, Luis Fariñas del Cerro, Marie-Christine Lagasquie-Schiex

► **To cite this version:**

Claudette Cayrol, Jorge Fandinno, Luis Fariñas del Cerro, Marie-Christine Lagasquie-Schiex. Argumentation Frameworks with Recursive Attacks and Evidence-Based Supports. [Research Report] IRIT-2018-01, IRIT - Institut de recherche en informatique de Toulouse. 2018. hal-02884137

**HAL Id: hal-02884137**

**<https://hal.science/hal-02884137>**

Submitted on 29 Jun 2020

**HAL** is a multi-disciplinary open access archive for the deposit and dissemination of scientific research documents, whether they are published or not. The documents may come from teaching and research institutions in France or abroad, or from public or private research centers.

L'archive ouverte pluridisciplinaire **HAL**, est destinée au dépôt et à la diffusion de documents scientifiques de niveau recherche, publiés ou non, émanant des établissements d'enseignement et de recherche français ou étrangers, des laboratoires publics ou privés.

# Argumentation Frameworks with Recursive Attacks and Evidence-Based Supports

Claudette Cayrol,  
Jorge Fandinno\*,  
Luis Fariñas del Cerro,  
M-Christine Lagasquie-Schiex

Université de Toulouse, IRIT,  
118 route de Narbonne, 31062 Toulouse, France  
{ccayrol, jorge.fandinno, luis, lagasq}@irit.fr

Tech. Report  
IRIT/RR- -2018- -01- -FR

---

\*The second author is funded by the Centre International de Mathématiques et d'Informatique de Toulouse (CIMI) through contract ANR-11-LABEX-0040-CIMI within the program ANR-11-IDEX-0002-02.

## Abstract

The purpose of this work is to study a generalisation of Dung’s abstract argumentation frameworks that allows representing positive interactions (called *supports*). The notion of support studied here is based in the intuition that every argument must be supported by some chain of supports from some special arguments called *prima-facie*. The theory developed here also allows the representation of both *recursive attacks* and *supports*, that is, a class of attacks or supports whose targets are other attacks or supports. We do this by developing a theory of argumentation where the classic role of *attacks* in defeating arguments is replaced by a subset of them, which is extension dependent and which, intuitively, represents a set of “valid attacks” with respect to the extension. Similarly, only the subset of “valid supports” is allowed to support other elements (arguments, attacks or supports). The studied theory displays a conservative generalisation of Dung’s semantics (complete, preferred and stable) and also of its principles (conflict-freeness, acceptability and admissibility). When restricted to finite non-recursive frameworks, we are also able to prove a one-to-one correspondence with Evidence-Based Argumentation (EBA). When supports are ignored a one-to-one correspondence with AFRA semantics is also established.

# Contents

<b>1</b>	<b>Introduction</b>	<b>1</b>
<b>2</b>	<b>Background</b>	<b>2</b>
2.1	Dung’s Argumentation . . . . .	3
2.2	Evidence-Based Argumentation . . . . .	4
<b>3</b>	<b>Recursive Evidence-Based Argumentation</b>	<b>5</b>
3.1	Recursive Evidence-Based Argumentation Frameworks . . . . .	5
3.2	Semantics of Recursive Evidence-Based Argumentation Frameworks . . . . .	7
<b>4</b>	<b>Relation with Recursive Argumentation Frameworks</b>	<b>11</b>
<b>5</b>	<b>Relation with Dung’s Argumentation Frameworks</b>	<b>12</b>
<b>6</b>	<b>Relation with Evidence-Based Argumentation Frameworks</b>	<b>14</b>
<b>7</b>	<b>Conclusions</b>	<b>15</b>
<b>A</b>	<b>Proofs</b>	<b>19</b>
A.1	Proofs of Section 3 . . . . .	21
A.2	Proof of section 6 . . . . .	24

# 1 Introduction

Argumentation has become an essential paradigm for Knowledge Representation and, especially, for reasoning from contradictory information [1, 15] and for formalizing the exchange of arguments between agents in, *e.g.*, negotiation [2]. Formal abstract frameworks have greatly eased the modelling and study of argumentation. For instance, a Dung’s argumentation framework (AF) [15] consists of a collection of arguments interacting with each other through an attack relation, enabling to determine “acceptable” sets of arguments called *extensions*.

Two natural generalisations of Dung’s argumentation frameworks consist in allowing positive interactions (usually expressed by a support relation) and allowing high-order attacks (that target other attacks or supports). Here is an example in the legal field, borrowed from [3].

**Example 1.** *The prosecutor says that the defendant has intention to kill the victim (argument b). A witness says that she saw the defendant throwing a sharp knife towards the victim (argument a). Argument a can be considered as a support for argument b. The lawyer argues back that the defendant was in a habit of throwing the knife at his wife’s foot once drunk. This latter argument (argument c) is better considered attacking the support from a to b, than arguments a or b themselves. Now the prosecutor’s argumentation seems no longer*

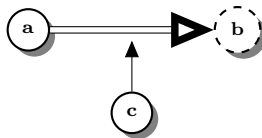

Figure 1: An acyclic recursive framework where supports (resp. attacks) are represented by double (resp. simple) arrows ended with a white (resp. black) triangle. Circles with solid border represent prima-facie arguments while dashed border ones represent standard arguments.

*sufficient for proving the intention to kill. This example is represented as a recursive framework in Fig. 1.* □

Positive interaction between arguments has been first introduced by [17, 24]. In [10], the support relation is left general so that the bipolar framework keeps a high level of abstraction. The associated semantics are based on the combination of the attack relation with the support relation which results in new complex attack relations. However there is no single interpretation of the support, and a number of researchers proposed specialized variants of the support relation (deductive support [6], necessary support [18, 19], evidential support [20, 21]). Each specialization can be associated with an appropriate modelling using an appropriate complex attack. These proposals have been developed quite independently, based on different intuitions and with different formalizations. [11]

presents a comparative study in order to restate these proposals in a common setting, the bipolar argumentation framework (see also [12] for another survey).

We follow here an evidential understanding of the support relation [20] that allows to distinguish between two different kinds of arguments: *prima-facie* and *standard arguments*. *Prima-facie* arguments were already present in [24] as those that are justified whenever they are not defeated. On the other hand, *standard arguments* are not directly assumed to be justified and must inherit support from *prima-facie* arguments through a chain of supports. For instance, in Example 1, arguments  $a$  and  $c$  are considered as *prima-facie* arguments while  $b$  is regarded as a *standard argument*. Hence, while  $a$  and  $c$  can be accepted as in Dung’s argumentation,  $b$  must inherit support from  $a$ : this holds if  $c$  is not accepted, but does not otherwise. Indeed, in the latter, the support from  $a$  to  $b$  is defeated by  $c$ .

In this paper, we apply the notion of *prima-facie*, not only to arguments, but also to interactions (attacks and supports). The intuition is that *prima-facie* elements (arguments, attack or supports) are elements that do not have to be supported. More precisely, we study a semantics for argumentation frameworks with recursive attacks *and* evidential supports, based on the following intuitive principles:

- P1** The role played in Dung’s argumentation frameworks by attacks in defeating arguments is now played by a subset of these attacks, which is extension dependent and represents the “valid attacks” with respect to that extension.
- P2** The notion of acceptability for *prima-facie* (and supported) arguments (resp. attacks or supports) is as in recursive frameworks without supports.
- P3** Non-*prima-facie* arguments (resp. attacks or supports) can only be “accepted” (resp. be “valid”) if there is a chain of “valid supports” rooted in some *prima-facie* arguments. These “valid supports” are also extension dependent.
- P4** It is a conservative generalisation of Dung’s framework for the notions of conflict-free, admissible, complete, preferred, and stable extensions.

The paper is organized as follows: the necessary background is given in Section 2; new semantics for recursive and evidence-based frameworks are proposed in Section 3; a comparison with existing frameworks is given in sections 4 to 6; and we conclude in Section 7.<sup>1</sup>

## 2 Background

We next review some basic background about Dung’s abstract argumentation frameworks [15] and Evidence-Based Argumentation (EBA) frameworks [20, 23].

---

<sup>1</sup>Proofs of formal results can be found in the appendix for review purposes.

## 2.1 Dung's Argumentation

**Definition 1.** A Dung's abstract argumentation framework (d-framework for short) is a pair  $\mathbf{dAF} = \langle \mathbf{A}, \mathbf{R} \rangle$  where  $\mathbf{A}$  is a set of arguments and  $\mathbf{R} \subseteq \mathbf{A} \times \mathbf{A}$  is a relation representing attacks over arguments.  $\square$

**Definition 2.** Given some d-framework  $\mathbf{dAF} = \langle \mathbf{A}, \mathbf{R} \rangle$  and some set of arguments  $E \subseteq \mathbf{A}$ , an argument  $a \in \mathbf{A}$  is said to be

- i) defeated w.r.t.  $E$  iff  $\exists b \in E$  such that  $(b, a) \in \mathbf{R}$ , and
- ii) acceptable w.r.t.  $E$  iff for every argument  $b \in \mathbf{A}$  with  $(b, a) \in \mathbf{R}$ , there is  $c \in E$  such that  $(c, b) \in \mathbf{R}$ .  $\square$

To obtain shorter definitions we will also use the following notations:

$$\begin{aligned} \text{Def}(E) &\stackrel{\text{def}}{=} \{ a \in \mathbf{A} \mid \exists b \in E \text{ s.t. } (b, a) \in \mathbf{R} \} \\ \text{Acc}(E) &\stackrel{\text{def}}{=} \{ a \in \mathbf{A} \mid \forall b \in \mathbf{A}, (b, a) \in \mathbf{R} \text{ implies } b \in \text{Def}(E) \} \end{aligned}$$

respectively denote the set of all defeated and acceptable arguments w.r.t.  $E$ .

**Definition 3.** Given a d-framework  $\mathbf{dAF} = \langle \mathbf{A}, \mathbf{R} \rangle$ , a set of arguments  $E \subseteq \mathbf{A}$  is said to be

- i) conflict-free iff  $E \cap \text{Def}(E) = \emptyset$ ,
- ii) admissible iff it is conflict-free and  $E \subseteq \text{Acc}(E)$ ,
- iii) complete iff it is conflict-free and  $E = \text{Acc}(E)$ ,
- iv) preferred iff it is  $\subseteq$ -maximal<sup>2</sup> admissible,
- v) stable iff it is conflict-free and  $E \cup \text{Def}(E) = \mathbf{A}$ .  $\square$

**Theorem 1** (From [15]). Given a d-framework  $\mathbf{dAF} = \langle \mathbf{A}, \mathbf{R} \rangle$ , the following assertions hold:

- i) every complete set is also admissible,
- ii) every preferred set is also complete, and
- iii) every stable set is also preferred.  $\square$

**Example 2.** Consider the d-framework corresponding to Fig.2. The argument



Figure 2: A d-framework

$a$  is accepted w.r.t. any set  $E$  because there is no argument  $x \in \mathbf{A}$  such that  $(x, a) \in \mathbf{R}$ . Furthermore,  $b$  is defeated and non-acceptable w.r.t. the set  $\{a\}$ . Then, it is easy to check that  $\{a\}$  is stable (and, thus, conflict-free, admissible, complete and preferred). The empty set  $\emptyset$  is admissible, but not complete; and the set  $\{b\}$  is conflict-free, but not admissible.

<sup>2</sup>With  $\subseteq$  denoting the standard set inclusion relation.

## 2.2 Evidence-Based Argumentation

We recall the formal definition of EBA frameworks. We follow here the definitions from [23] which correct some technical flaws from [20].

**Definition 4** (Evidence-Based Argumentation framework). *An Evidence-Based Argumentation framework (EBAF) is a tuple  $\mathbf{EBAF} = \langle \mathbf{A}, \mathbf{R}_a, \mathbf{R}_e \rangle$  where  $\mathbf{A}$  represents a set of arguments,  $\mathbf{R}_a \subseteq (2^{\mathbf{A}} \setminus \emptyset) \times \mathbf{A}$  is an attack relation and  $\mathbf{R}_e \subseteq (2^{\mathbf{A}} \setminus \emptyset) \times \mathbf{A}$  is a support relation. A special argument  $\eta \in \mathbf{A}$  is distinguished satisfying that there is no  $(B, \eta) \in \mathbf{R}_a \cup \mathbf{R}_e$  for any set  $B$  nor there is  $(B, a) \in \mathbf{R}_a$  with  $\eta \in B$ . We say that  $\mathbf{EBAF}$  is (in)finite iff  $\mathbf{A}$  is (in)finite.*  $\square$

The special argument  $\eta$  serves as a representation of the prima-facie arguments. Note that the attack relation is not a binary relation. Instead, there can be an attack from a *set of arguments* to another argument, something which is not the case in d-frameworks.

**Definition 5** (Evidential Support). *An argument  $a \in \mathbf{A}$  is e-supported by a set  $B \subseteq \mathbf{A}$  iff the two following conditions hold:*

1.  $a = \eta$ , or
2. *there is a non-empty  $C \subseteq B$  s.t.  $(C, a) \in \mathbf{R}_e$  and every  $c \in C$  is e-supported by  $B \setminus \{a\}$ .*  $\square$

*$B$  is said to be a minimal e-support for  $a$  iff there is no  $C \subset B$  such that  $a$  is e-supported by  $C$ .*  $\square$

Note that  $\eta$  is e-supported by any set  $B \subseteq \mathbf{A}$ .

**Definition 6** (Evidence-Supported Attack). *A pair  $(B, a)$  is said to be an evidence-supported attack (e-attack) iff (i) there is  $(C, a) \in \mathbf{R}_a$  with  $C \subseteq B$  and (ii) all elements in  $C$  are e-supported by  $B$ .  $(B, a)$  is said to be a minimal e-attack if there is no e-attack  $(C, a)$  with  $C \subset B$ .*  $\square$

We will say that  $B$  e-supports  $a$  or that  $(B, a)$  is an e-support when  $a$  is e-supported by  $B$  and that  $B$  e-attacks  $a$  when  $(B, a)$  is an e-attack.

**Definition 7** (Acceptability). *Given some framework  $\mathbf{EBAF} = \langle \mathbf{A}, \mathbf{R}_a, \mathbf{R}_e \rangle$ , an argument  $a \in \mathbf{A}$  is said to be acceptable w.r.t. a set  $E \subseteq \mathbf{A}$  iff the following two conditions are satisfied:*

1.  $a$  is e-supported by  $E$ , and
2. *for every minimal e-attack  $(B, a)$ , it holds that  $E$  e-attacks some  $b \in B$ .*  $\square$

**Definition 8** (Semantics). *A set of arguments  $E \subseteq \mathbf{A}$  is said to be*

1. *self-supporting iff all arguments  $a \in E$  are e-supported by  $E$ ,*
2. *conflict-free iff, for every  $a \in E$ , there is no  $B \subseteq E$  such that  $(B, a) \in \mathbf{R}_a$ ,*



3. admissible iff it is conflict-free and all arguments  $a \in E$  are acceptable w.r.t.  $E$ ,
4. complete iff it is admissible and all acceptable arguments w.r.t.  $E$  are in  $E$ ,
5. preferred iff it is a  $\subseteq$ -maximal admissible set,
6. stable iff it is self-supporting, conflict-free and any argument  $a \notin E$  which is e-supported by  $\mathbf{A}$  satisfies that  $E$  e-attacks either  $a$  or every minimal e-support  $B$  of  $a$ .  $\square$

### 3 Recursive Evidence-Based Argumentation

In this section, we extend the semantics proposed for recursive attacks in [9] with the purpose of handling evidence-based supports.

#### 3.1 Recursive Evidence-Based Argumentation Frameworks

**Definition 9** (Recursive Evidence-Based Argumentation Framework). *An (evidence-based recursive) argumentation framework  $\mathbf{AF} = \langle \mathbf{A}, \mathbf{K}, \mathbf{S}, \mathbf{s}, \mathbf{t}, \mathbf{P} \rangle$  is a sextuple where  $\mathbf{A}$ ,  $\mathbf{K}$  and  $\mathbf{S}$  are three (possible infinite) pairwise disjoint sets respectively representing arguments, attacks and supports names, and where  $\mathbf{P} \subseteq \mathbf{A} \cup \mathbf{K} \cup \mathbf{S}$  is a set representing the prima-facie elements that do not need to be supported. Functions  $\mathbf{s} : (\mathbf{K} \cup \mathbf{S}) \rightarrow 2^{\mathbf{A}}$  and  $\mathbf{t} : (\mathbf{K} \cup \mathbf{S}) \rightarrow (\mathbf{A} \cup \mathbf{K} \cup \mathbf{S})$  respectively map each attack and support to its source and its target.  $\square$*

As in EBAFs, the source of attacks and supports is a set of arguments. It is obvious that any attack  $(a, b)$  in a d-framework can be represented by assigning to it some name  $\alpha$  that satisfies  $\mathbf{s}(\alpha) = \{a\}$  and  $\mathbf{t}(\alpha) = b$ . It is also worth mentioning that, from an evidential point of view, every argument and attack of a d-framework is prima-facie. That is, given some  $\mathbf{dAF} = \langle \mathbf{A}, \mathbf{R} \rangle$ , we can build a corresponding recursive framework  $\mathbf{AF} = \langle \mathbf{A}, \mathbf{K}, \mathbf{S}, \mathbf{s}, \mathbf{t}, \mathbf{P} \rangle$  where  $\mathbf{K}$  is a set of names of the same cardinality of  $\mathbf{R}$ , where  $\mathbf{S} = \emptyset$  is the empty set of supports,  $\mathbf{s}$  and  $\mathbf{t}$  map each attack name to its corresponding source and target, and the set of prima-facie elements  $\mathbf{P} = \mathbf{A} \cup \mathbf{K}$  includes all arguments and attacks.

**Example 3.** *In particular, the d-framework associated with Figure 2 corresponds to the  $\mathbf{AF} = \langle \mathbf{A}, \mathbf{K}, \mathbf{S}, \mathbf{s}, \mathbf{t}, \mathbf{P} \rangle$  with  $\mathbf{A} = \{a, b\}$ ,  $\mathbf{K} = \{\alpha\}$ ,  $\mathbf{s}(\alpha) = \{a\}$ ,  $\mathbf{t}(\alpha) = b$  and  $\mathbf{P} = \{a, b, \alpha\}$ .  $\square$*

Note also that, different from EBAFs, the set  $\mathbf{P}$  may contain several prima-facie elements (arguments, attacks and supports). This is not a substantial difference, but allows that any graph representing a d-framework has the same semantics when interpreted in our framework. For instance, Figure 3 depicts the framework of Figure 2 making explicit the attack name. Note that we use squares in the middle of the arrows to represent attack and support names. As with arguments, a solid border denotes prima-facie elements while a dashed

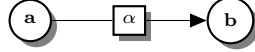

Figure 3: An AF with named attack.

border denotes standard elements. By following this notation every graph within Dung’s theory preserves the same semantics, something which is in accordance with principle **P4**. Note also that, in contrast with EBAFs, we not assume any constraint on the prima-facie elements, they can be attacked or supported (though supporting prima-facie elements do not make any semantical difference from not doing so).

**Example 4.** As an illustration of frameworks with recursive attacks and supports, consider the argumentation frameworks  $\mathbf{AF}_1 = \langle \mathbf{A}_1, \mathbf{K}_1, \mathbf{S}_1, \mathbf{P}_1, \mathbf{s}_1, \mathbf{t}_1 \rangle$  and  $\mathbf{AF}_2 = \langle \mathbf{A}_2, \mathbf{K}_2, \mathbf{S}_2, \mathbf{P}_2, \mathbf{s}_2, \mathbf{t}_2 \rangle$  where  $\mathbf{A}_1 = \{a, b, c\}$ ,  $\mathbf{K}_1 = \{\beta\}$ ,  $\mathbf{S}_1 = \{\alpha\}$ ,  $\mathbf{A}_2 = \{a, b, c, d\}$ ,  $\mathbf{K}_2 = \{\alpha, \beta\}$ ,  $\mathbf{S}_2 = \{\gamma, \delta\}$ , functions  $\mathbf{s}_1$ ,  $\mathbf{t}_1$ ,  $\mathbf{s}_2$  and  $\mathbf{t}_2$  satisfy

$$\begin{array}{ll}
 \mathbf{s}_1(\alpha) = \{a\} & \mathbf{t}_1(\alpha) = b \\
 \mathbf{s}_1(\beta) = \{c\} & \mathbf{t}_1(\beta) = \alpha \\
 \mathbf{s}_2(\alpha) = \{a\} & \mathbf{t}_2(\alpha) = b \\
 \mathbf{s}_2(\beta) = \{a\} & \mathbf{t}_2(\beta) = b \\
 \mathbf{s}_2(\gamma) = \{c\} & \mathbf{t}_2(\gamma) = \alpha \\
 \mathbf{s}_2(\delta) = \{d\} & \mathbf{t}_2(\delta) = \beta
 \end{array}$$

and  $\mathbf{P}_1 = \{a, c, \alpha, \beta\}$ , and  $\mathbf{P}_2 = \{a, b, c, d, \gamma, \delta\}$ . These two frameworks can be respectively depicted as the graphs in Figures 4a and 4b. It is worth to note

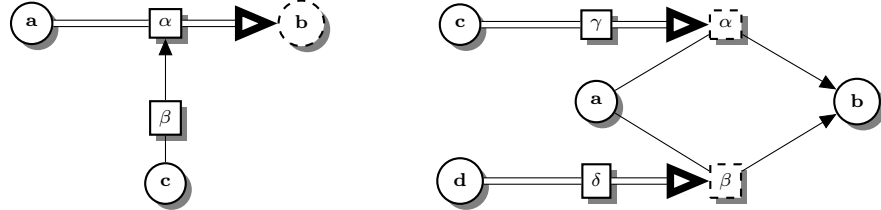

(a) The graph of Fig.1 with attack and support names

(b) A recursive framework representing attacks in different contexts

Figure 4: Recursive frameworks with prima-facie elements

that Figure 4a is just the result of naming attacks and supports in Figure 1. On the other hand, Figure 4b represents a framework with two attacks between  $a$  and  $b$  that hold in different contexts:  $\alpha$  and  $\beta$  are two standard attacks that are respectively supported by different prima-facie arguments,  $c$  and  $d$  respectively, that represent those different contexts.  $\square$

It is worth to mention that the reason to use explicit names for attacks and supports in Definition 9 instead of just relations is twofold. First, this allows

the existence of several attacks or supports between the same elements that can be used to represent different contexts as illustrated in Example 4. The second

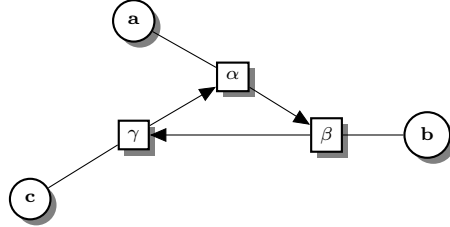

Figure 5: A cyclic recursive framework

reason is due to the possible existence of cycles of attacks or supports, which has no trivial finite representation as a relation: for instance, attack  $\alpha$  in Figure 5 would correspond to the infinite object  $(\{a\}, (\{b\}, (\{c\}, (\{a\}, \dots))))$ .

### 3.2 Semantics of Recursive Evidence-Based Argumentation Frameworks

We introduce next the notion of structure, which will allow us to characterise which arguments are regarded as “acceptable,” and which attacks and supports are regarded as “valid,” with respect to some argumentation framework. The notion of structure is analogous to the notion of set of arguments and it will be the base to define the corresponding argumentation semantics for recursive frameworks.

**Definition 10** (Structure). *A triple  $\mathfrak{A} = \langle E, \Gamma, \Delta \rangle$  is said to be a structure of some  $\mathbf{AF} = \langle \mathbf{A}, \mathbf{K}, \mathbf{S}, \mathbf{s}, \mathbf{t}, \mathbf{P} \rangle$  iff it satisfies:  $E \subseteq \mathbf{A}$ ,  $\Gamma \subseteq \mathbf{K}$  and  $\Delta \subseteq \mathbf{S}$ .  $\square$*

Intuitively, the set  $E$  represents the set of “acceptable” arguments w.r.t. the structure  $\mathfrak{A}$ , while  $\Gamma$  and  $\Delta$  respectively represent the set of “valid attacks” and “valid supports” w.r.t.  $\mathfrak{A}$ . Any attack<sup>3</sup>  $\alpha \in \Gamma$  is understood as non-valid and, in this sense, it cannot defeat the element that it is targeting. Similarly, any support  $\beta \in \Delta$  is understood as non-valid and it cannot support the element that it is targeting.

For the rest of this section we assume that all definitions and results are relative to some given framework  $\mathbf{AF} = \langle \mathbf{A}, \mathbf{K}, \mathbf{S}, \mathbf{s}, \mathbf{t}, \mathbf{P} \rangle$ . We extend now the definition of defeated arguments (Definition 2) using the set  $\Gamma$  instead of the attack relation  $\mathbf{R}$ : given a structure of the form  $\mathfrak{A} = \langle E, \Gamma, \Delta \rangle$ , we define:

$$Def_X(\mathfrak{A}) \stackrel{\text{def}}{=} \{x \in X \mid \exists \alpha \in \Gamma, \mathbf{s}(\alpha) \subseteq E \text{ and } \mathbf{t}(\alpha) = x\} \quad (1)$$

<sup>3</sup>By  $\bar{\Gamma} \stackrel{\text{def}}{=} \mathbf{K} \setminus \Gamma$  we denote the set complement of  $\Gamma$  w.r.t.  $\mathbf{K}$ . Similarly, by  $\bar{\Delta} \stackrel{\text{def}}{=} \mathbf{S} \setminus \Delta$  we denote the set complement of  $\Delta$  w.r.t.  $\mathbf{S}$ .

with  $X \in \{\mathbf{A}, \mathbf{K}, \mathbf{S}\}$ . In other words, an element  $x$  is defeated w.r.t.  $\mathfrak{A}$  iff there is a “valid attack” w.r.t.  $\mathfrak{A}$  that targets  $x$  and whose source is “acceptable” w.r.t.  $\mathfrak{A}$ . It is interesting to observe that we may define the *attack relation* associated with some structure  $\mathfrak{A} = \langle E, \Gamma, \Delta \rangle$  as follows:

$$\mathbf{R}_{\mathfrak{A}} \stackrel{\text{def}}{=} \{ (\mathbf{s}(\alpha), \mathbf{t}(\alpha)) \mid \alpha \in \Gamma \} \quad (2)$$

and that, using this relation, we can rewrite (1) as:

$$\text{Def}_X(\mathfrak{A}) \stackrel{\text{def}}{=} \{ x \in X \mid \exists B \subseteq E \text{ s.t. } (B, x) \in \mathbf{R}_{\mathfrak{A}} \} \quad (3)$$

Now, it is easy to see that our definition for  $\text{Def}_{\mathbf{A}}(\mathfrak{A})$  can be obtained from Dung’s definition of defeat (Definition 2) just by replacing the attack relation  $\mathbf{R}$  by the attack relation  $\mathbf{R}_{\mathfrak{A}}$  associated with the structure  $\mathfrak{A}$  and  $\exists b \in E$  by  $\exists B \subseteq E$ , or in other words, by replacing the set of all attacks in the argumentation framework by the set of the “valid attacks” w.r.t. the structure  $\mathfrak{A}$ , as stated in **P1**; and allowing the source of attacks to be, not just arguments, but sets of them.

By  $\text{Def}(\mathfrak{A}) \stackrel{\text{def}}{=} \text{Def}_{\mathbf{A}}(\mathfrak{A}) \cup \text{Def}_{\mathbf{K}}(\mathfrak{A}) \cup \text{Def}_{\mathbf{S}}(\mathfrak{A})$ , we will denote the set of all defeated arguments. By  $\overline{\text{Def}}_X(\mathfrak{A}) \stackrel{\text{def}}{=} X \setminus \text{Def}_X(\mathfrak{A})$  with  $X \in \{\mathbf{A}, \mathbf{K}, \mathbf{S}\}$ , we denote the non-defeated arguments (resp. attacks, supports) w.r.t.  $\mathfrak{A}$ . Furthermore, by  $\overline{\text{Def}}(\mathfrak{A}) \stackrel{\text{def}}{=} (\mathbf{A} \cup \mathbf{K} \cup \mathbf{S}) \setminus \text{Def}(\mathfrak{A})$ , we denote the set of all non-defeated elements.

*Example 4 (cont’d)* Consider the framework corresponding to Figure 4a, and the structure  $\mathfrak{A} = \langle E, \Gamma, \Delta \rangle$  with  $E = \{a, c\}$ ,  $\Gamma = \{\beta\}$  and  $\Delta = \emptyset$ . Then, we have that  $\text{Def}(\mathfrak{A}) = \{\alpha\}$ .  $\square$

Let us now introduce the notion of *supported elements* w.r.t. a structure. Intuitively, it should be noted that the prima-facie elements (arguments, attacks, supports) of a given framework are supported for any structure. Then, a standard element is supported if there exists a chain of supported supports, leading to it, which is rooted in prima-facie arguments. Formally, given some framework  $\mathbf{AF} = \langle \mathbf{A}, \mathbf{K}, \mathbf{S}, \mathbf{s}, \mathbf{t}, \mathbf{P} \rangle$  and some structure  $\mathfrak{A} = \langle E, \Gamma, \Delta \rangle$ , the set of supported elements  $\text{Sup}(\mathfrak{A})$  is recursively defined as follows<sup>4</sup>:

$$\text{Sup}(\mathfrak{A}) \stackrel{\text{def}}{=} \mathbf{P} \cup \{ \mathbf{t}(\alpha) \mid \exists \alpha \in \Delta \cap \text{Sup}(\mathfrak{A}') , \mathbf{s}(\alpha) \subseteq E \cap \text{Sup}(\mathfrak{A}') \} \quad (4)$$

with<sup>5</sup>  $\mathfrak{A}' = \mathfrak{A} \setminus \{ \mathbf{t}(\alpha) \}$ . By  $\text{Sup}_X(\mathfrak{A}) \stackrel{\text{def}}{=} \text{Sup}(\mathfrak{A}) \cap X$  with  $X \in \{\mathbf{A}, \mathbf{K}, \mathbf{S}\}$ , we respectively denote the set of all supported arguments, attacks and supports.

*Example 4 (cont’d)* Consider the framework corresponding to Figure 4a, and the structure  $\mathfrak{A} = \langle E, \Gamma, \Delta \rangle$  with  $E = \{a, b, c\}$ ,  $\Gamma = \emptyset$  and  $\Delta = \{\alpha\}$ . Let us prove that  $b \in \text{Sup}(\mathfrak{A})$ . Note that  $b = \mathbf{t}(\alpha)$  with  $\alpha \in \Delta$ . So we have to prove that  $\alpha$  and  $a \in \mathbf{s}(\alpha) = \{a\}$  both belong to  $\text{Sup}(\mathfrak{A} \setminus \{b\})$ . That is true since  $\alpha$  and  $a$  both belong to  $\mathbf{P}$ .

**Example 5.** *As a further example, consider the framework corresponding to the graph depicted in Figure 6 and let  $\mathfrak{A} = \langle E, \Gamma, \Delta \rangle$  be a structure with  $E =$*

<sup>4</sup>Note that  $E = \emptyset$  and  $\Delta = \emptyset$  act as base cases, because  $E = \emptyset$  (resp.  $\Delta = \emptyset$ ) implies  $\text{Sup}(\mathfrak{A}) = \mathbf{P}$ .

<sup>5</sup>By abuse of notation, we write  $\mathfrak{A} \setminus T$  instead of  $\langle E \setminus T, \Gamma \setminus T, \Delta \setminus T \rangle$  with  $T \subseteq (\mathbf{A} \cup \mathbf{K} \cup \mathbf{S})$ .

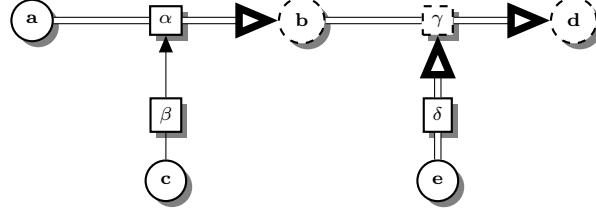

Figure 6: A recursive framework with prima-facie elements

$\{a, b, c, d, e\}$ ,  $\Gamma = \emptyset$  and  $\Delta = \{\alpha, \gamma, \delta\}$ . Then, we have that  $Sup(\mathfrak{A}) = \{a, b, c, d, e, \alpha, \beta, \gamma, \delta\}$ . Note that  $a, c, e, \alpha, \beta$  and  $\delta$  are supported because they are prima-facie elements. It is also easy to see that  $b$  is supported as in the previous example and that  $\gamma$  is supported through  $\delta$  by  $e$ . So,  $b$  and  $\gamma$  both belong to  $Sup(\mathfrak{A}\{d\})$ . Hence,  $d$  is also supported.  $\square$

Now, drawing on the notion of supported elements w.r.t. a given structure  $\mathfrak{A}$ , we are able to define the *supportable* elements w.r.t.  $\mathfrak{A}$ . Intuitively, an element is considered as being still supportable as long as there exists some non-defeated support with all its source elements non-defeated and regarded, in its turn, as supportable. Formally, an element  $x$  is supportable w.r.t.  $\mathfrak{A}$  iff  $x$  is supported w.r.t.  $\mathfrak{A}' = \langle \overline{Def}_{\mathbf{A}}(\mathfrak{A}), \mathbf{K}, \overline{Def}_{\mathbf{S}}(\mathfrak{A}) \rangle$ . Elements that are defeated or that are unsupportable cannot be accepted. In this sense, by  $UnAcc(\mathfrak{A}) \stackrel{\text{def}}{=} \overline{Def}(\mathfrak{A}) \cup Sup(\mathfrak{A}')$  we denote the *unacceptable* elements w.r.t.  $\mathfrak{A}$ . Moreover, we say that an attack  $\alpha \in \mathbf{K}$  is *unactivable* iff either it is unacceptable or some element in its source is unacceptable, that is,

$$UnAct(\mathfrak{A}) \stackrel{\text{def}}{=} \{ \alpha \in \mathbf{K} \mid \alpha \in UnAcc(\mathfrak{A}) \text{ or } \mathbf{s}(\alpha) \cap UnAcc(\mathfrak{A}) \neq \emptyset \}$$

**Definition 11** (Acceptability). *An element  $x \in \mathbf{A} \cup \mathbf{K} \cup \mathbf{S}$  is said to be acceptable w.r.t. a structure  $\mathfrak{A}$  iff (i)  $x \in Sup(\mathfrak{A})$  and (ii) every attack  $\alpha \in \mathbf{K}$  with  $\mathbf{t}(\alpha) = x$  is unactivable, that is,  $\alpha \in UnAct(\mathfrak{A})$ .  $\square$*

By  $Acc(\mathfrak{A})$ , we denote the set containing all arguments, attacks and supports that are acceptable with respect to  $\mathfrak{A}$ .

It is worth to note that, intuitively, an element is acceptable iff it is supported and, in addition, every attack against it is somehow “inhibited,” where by “inhibited” here we mean that either some argument in its source or itself has been regarded as unacceptable.

**Example 6.** *Consider the argumentation framework of Figure 7, and the structure  $\mathfrak{A} = \langle \{a, b, c, e\}, \{\alpha, \kappa, \gamma\}, \emptyset \rangle$ . We have that  $c$  is acceptable w.r.t.  $\mathfrak{A}$ . Note that there are two attacks against  $c$ :  $\beta$  is defeated through  $\alpha$  by  $a$ , while  $\gamma$  is unactivable because  $d$  is unsupported since  $\delta$  is defeated by  $\kappa$ .  $\square$*

We also define the following order relations that will help us defining preferred structures: for any pair of structures  $\mathfrak{A} = \langle E, \Gamma, \Delta \rangle$  and  $\mathfrak{A}' = \langle E', \Gamma', \Delta' \rangle$ ,

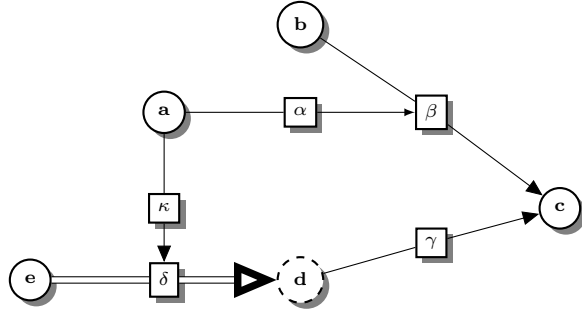

Figure 7: Argumentation framework corresponding to Example 6.

we write  $\mathfrak{A} \sqsubseteq \mathfrak{A}'$  iff  $(E \cup \Gamma \cup \Delta) \subseteq (E' \cup \Gamma' \cup \Delta')$ . As usual, we say that a structure  $\mathfrak{A}$  is  $\sqsubseteq$ -maximal iff every  $\mathfrak{A}'$  that satisfies  $\mathfrak{A} \sqsubseteq \mathfrak{A}'$  also satisfies  $\mathfrak{A}' \sqsubseteq \mathfrak{A}$ .

**Definition 12.** A structure  $\mathfrak{A} = \langle E, \Gamma, \Delta \rangle$  is said to be:

- i) self-supporting iff  $(E \cup \Gamma \cup \Delta) \subseteq \text{Sup}(\mathfrak{A})$ ,
- ii) conflict-free iff  $X \cap \text{Def}_Y(\mathfrak{A}) = \emptyset$  for any  $(X, Y) \in \{(E, \mathbf{A}), (\Gamma, \mathbf{K}), (\Delta, \mathbf{S})\}$ ,
- iii) admissible iff it is conflict-free and  $E \cup \Gamma \cup \Delta \subseteq \text{Acc}(\mathfrak{A})$ ,
- iv) complete iff it is conflict-free and  $\text{Acc}(\mathfrak{A}) = E \cup \Gamma \cup \Delta$ ,
- v) preferred iff it is a  $\sqsubseteq$ -maximal admissible structure,
- vi) stable<sup>6</sup> iff  $(E \cup \Gamma \cup \Delta) = \overline{\text{UnAcc}(\mathfrak{A})}$ .

□

*Example 4 (cont'd)* The framework of Figure 4a has a unique complete, preferred and stable structure  $\mathfrak{A} = \langle \{a, c\}, \{\beta\}, \emptyset \rangle$ . Note that  $\alpha$  cannot be accepted because it is defeated by  $c$  through  $\beta$ , while  $b$  cannot be accepted because, now, it lacks support.

*Example 5 (cont'd)* The framework of Figure 6 has also a unique complete, preferred and stable structure  $\mathfrak{A} = \langle \{a, c, e\}, \{\beta\}, \{\gamma, \delta\} \rangle$ . As above,  $\alpha$  cannot be accepted because it is defeated by  $c$  through  $\beta$  which implies that  $b$  and  $d$  cannot be accepted because of lack of support.  $\gamma$  is acceptable because it is supported through  $\delta$  by  $e$  and not attacked. □

*Example 6 (cont'd)*  $\mathfrak{A} = \langle \{a, b, c, e\}, \{\alpha, \kappa, \gamma\}, \emptyset \rangle$  is the unique complete, preferred and stable structure w.r.t. the framework of Figure 7. □

We show now that, as in Dung's argumentation theory, there is also a kind of Fundamental Lemma for argumentation frameworks with recursive attacks and evidence-based supports.

<sup>6</sup>Note also this already implies conflict-freeness.

**Lemma 1** (Fundamental Lemma). *Let  $\mathfrak{A} = \langle E, \Gamma, \Delta \rangle$  be an admissible structure and  $x, y \in \text{Acc}(\mathfrak{A})$  be any pair of acceptable elements. Then,<sup>7</sup> (i)  $\mathfrak{A}' = \mathfrak{A} \cup \{x\}$  is an admissible structure, and (ii)  $y \in \text{Acc}(\mathfrak{A}')$ .  $\square$*

Moreover, admissible structures form a complete partial order with preferred structures as maximal elements:

**Proposition 1.** *The set of all admissible structures forms a complete partial order with respect to  $\sqsubseteq$ . Furthermore, for every admissible structure  $\mathfrak{A}$ , there exists a preferred one  $\mathfrak{A}'$  such that  $\mathfrak{A} \sqsubseteq \mathfrak{A}'$ .  $\square$*

The following result shows that the usual relation between extensions also holds for structures.

**Theorem 2.** *The following assertions hold:*

- i) every admissible structure is also self-supporting,*
- ii) every complete structure is also admissible,*
- iii) every preferred structure is also complete, and*
- iv) every stable structure is also preferred.  $\square$*

**Example 7.** *As a further example, consider the framework corresponding to Figure 8. This framework has a unique complete and preferred structure  $\mathfrak{A} =$*

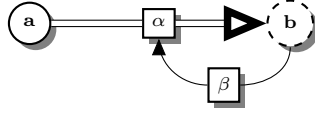

Figure 8: A cyclic recursive framework

$\langle \{a\}, \{\beta\}, \emptyset \rangle$ , but no stable one. Note that  $\alpha$  and  $b$  are neither acceptable nor unacceptable w.r.t.  $\mathfrak{A}$ :  $\alpha$  is not unacceptable because it is supportable (it is prima-facie) and it is not defeated ( $b$  is not in the structure) and it is not acceptable because it is attacked by  $b$ , which is still not unacceptable. Similarly,  $b$  is not unacceptable because it is still supportable through  $\alpha$ , but it is not supported (and, thus not acceptable) because  $\alpha$  is not in the structure.  $\square$

## 4 Relation with Recursive Argumentation Frameworks

As mentioned in Section 3, our framework is a conservative generalisation of the Recursive Argumentation Framework (RAF) defined in [9] with the addition of supports and joint attacks. RAF's attacks are similar to Dung's attacks

<sup>7</sup>By abuse of notation, we write  $\mathfrak{A} \cup T$  instead of  $\langle E \cup (T \cap \mathbf{A}), \Gamma \cup (T \cap \mathbf{K}), \Delta \cup (T \cap \mathbf{S}) \rangle$  with  $T \subseteq (\mathbf{A} \cup \mathbf{K} \cup \mathbf{S})$ .

with the only difference that they may target, not only arguments, but also other attacks. Hence, translating RAF's (or Dung's) attacks into joint attacks is trivial: every attack with source  $a$  is replaced by an attack with the singleton set  $\{a\}$  as its source. On the other hand, like Dung's frameworks, RAFs do not encompass the notion of support. From an evidential point of view it is as every argument or attack was externally supported, or in other words, as attacks and arguments were prima-facie. In this sense, every  $\mathbf{RAF} = \langle \mathbf{A}, \mathbf{K}, \mathbf{s}, \mathbf{t} \rangle$  can be translated into a corresponding recursive evidence-based argumentation framework of the form  $\mathbf{AF} = \langle \mathbf{A}, \mathbf{K}, \mathbf{S}, \mathbf{s}', \mathbf{t}, \mathbf{P} \rangle$  with  $\mathbf{S} = \emptyset$  (no supports), where every element is considered as prima-facie, that is  $\mathbf{P} = \mathbf{A} \cup \mathbf{K}$ , and where  $\mathbf{s}'$  satisfies  $\mathbf{s}'(\alpha) = \{\mathbf{s}(\alpha)\}$  for every attack  $\alpha \in \mathbf{K}$ . It is easy to check that a structure  $\langle E, \Gamma \rangle$  is conflict-free (resp. admissible, complete, preferred, stable) w.r.t. some  $\mathbf{RAF}$  iff  $\langle E, \Gamma, \emptyset \rangle$  is conflict-free (resp. admissible, complete, preferred, stable) w.r.t. its corresponding  $\mathbf{AF}$ . Furthermore, there is a one-to-one correspondence between complete, preferred and stable structures in RAF's and their corresponding Dung's extensions, so this correspondence is also carried over to our argumentation frameworks with evidence-based support. In [9], it also has been shown that there is a one-to-one correspondence between RAF and AFRA [4], which is also carried over to our frameworks (when we restrict ourselves to frameworks without supports). Note that AFRA has been extended with supports in [13, 14] and called Attack-Support Argumentation Framework (ASAF). However, ASAF supports are understood as necessary conditions for their targets instead. This is quite different from the evidential understanding followed here as shown by the following example.

**Example 8.** *According to ASAF, the set  $\{a, b, \alpha, \beta\}$  is a complete, preferred and stable w.r.t. the framework of Figure 9. On the other hand, in our framework,*

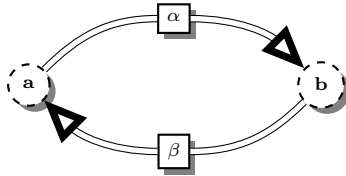

Figure 9: A framework with a cycle of supports

$\langle \{a, b\}, \emptyset, \{\alpha, \beta\} \rangle$  is not admissible (and, thus, not complete, preferred nor stable) because neither  $a$  nor  $b$  are supported by a chain rooted in some prima-facie argument.  $\square$

## 5 Relation with Dung's Argumentation Frameworks

It is also worth to mention, that the one-to-one correspondence between RAF (or either AFRA or ASAF) and Dung's frameworks is not directly applicable to



conflict-free or admissible sets as illustrated by the following example:

*Example 2 (cont'd)* Consider the argumentation framework corresponding to Figure 3. According to Dung’s theory, this framework has three conflict-free sets, namely  $\emptyset$ ,  $\{a\}$  and  $\{b\}$ , which respectively correspond to the structures:  $\langle \emptyset, \{\alpha\}, \emptyset \rangle$ ,  $\langle \{a\}, \{\alpha\}, \emptyset \rangle$  and  $\langle \{b\}, \{\alpha\}, \emptyset \rangle$ . On the other hand,  $\langle \{a, b\}, \emptyset, \emptyset \rangle$  is a conflict-free structure because the attack  $\alpha$  is not considered valid. Similarly,  $\{a, b\}$  is a conflict-free set according to AFRA or ASAF.  $\square$

The difference between Dung’s argumentation frameworks and these three semantics for recursive attacks, illustrated by the above example, can be explained by the fact that, in Dung’s theory, every attack is considered as “valid” in the sense that it may affect its target. In [9], it has been shown that a one-to-one correspondence with Dung’s theory, for conflict-free and admissible sets, can be recovered by adding a kind of reinstatement principle on attacks, which forces all attacks that cannot be defeated to be “valid”. The following extends the definition of d-structure from [9] to the case of supports by strengthening the notion of structure according to the above intuition:

**Definition 13** (D-structure). *Given some framework  $\mathbf{AF} = \langle \mathbf{A}, \mathbf{K}, \mathbf{S}, \mathbf{s}, \mathbf{t}, \mathbf{P} \rangle$ , a structure  $\mathfrak{A} = \langle E, \Gamma, \Delta \rangle$  is said to be a d-structure iff it satisfies  $(\text{Acc}(\mathfrak{A}) \cap \mathbf{K}) \subseteq \Gamma$  and  $(\text{Acc}(\mathfrak{A}) \cap \mathbf{S}) \subseteq \Delta$ . Then, a conflict-free (resp. admissible, complete, preferred or stable) d-structure is a conflict-free (resp. admissible, complete, preferred, stable) structure which is also a d-structure.  $\square$*

As a direct consequence of Definition 12 and Theorem 2, we have:

**Observation 1.** *Every complete (resp. preferred or stable) structure is also a d-structure.  $\square$*

It is easy to check that a structure  $\langle E, \Gamma \rangle$  is a d-structure w.r.t. some **RAF** (as defined in [9]) iff  $\langle E, \Gamma, \emptyset \rangle$  is a d-structure w.r.t. its corresponding **AF**. Hence, the following result is an immediate consequence of Theorem 4 in [9]:

**Theorem 3.** *Let  $\mathbf{AF} = \langle \mathbf{A}, \mathbf{K}, \mathbf{S}, \mathbf{s}, \mathbf{t}, \mathbf{P} \rangle$  be some non-recursive framework with  $\mathbf{S} = \emptyset$ ,  $\mathbf{P} = \mathbf{A} \cup \mathbf{K}$ , and that, for all  $\alpha \in \mathbf{K}$ , satisfies<sup>8</sup>  $|\mathbf{s}(\alpha)| = 1$  and  $\mathbf{t}(\alpha) \in \mathbf{A}$ . Then, a d-structure  $\mathfrak{A} = \langle E, \mathbf{K}, \emptyset \rangle$  is conflict-free (resp. admissible, complete, preferred or stable) w.r.t. **AF** (Definition 13) iff it is conflict-free (resp. admissible, complete, preferred or stable) w.r.t.  $\mathbf{dAF} = \langle \mathbf{A}, \mathbf{R}_{\mathbf{AF}} \rangle$  (Definition 3) with the relation  $\mathbf{R}_{\mathbf{AF}} \stackrel{\text{def}}{=} \{ (a, \mathbf{t}(\alpha)) \mid \alpha \in \mathbf{K} \text{ and } \mathbf{s}(\alpha) = \{a\} \}$ .  $\square$*

Theorem 3 formalises how any d-framework can be represented as an **AF**: in particular, in these frameworks, all elements are prima-facie  $\mathbf{P} = \mathbf{A} \cup \mathbf{K}$  (so supports are not needed  $\mathbf{S} = \emptyset$ ). Furthermore, an attack only targets arguments,  $\mathbf{t}(\alpha) \in \mathbf{A}$  for all  $\alpha \in \mathbf{K}$ , and the source is a single argument, represented by the restriction to singleton sets  $|\mathbf{s}(\alpha)| = 1$ .

<sup>8</sup>Given a set  $S$ , by  $|S|$  we denote its cardinality.

## 6 Relation with Evidence-Based Argumentation Frameworks

As mentioned in the introduction, (non-recursive) EBAFs were first introduced in [20]. When we are restricted to non-recursive frameworks, the major difference between EBAFs and our frameworks comes from the way in which the notion of acceptability is defined. In both cases, every acceptable argument must also be supported but while, in EBAFs, acceptability relies on what is called *evidence-supported attack* (*e-attack* for short), in our theory, it relies on the idea that arguments are *unacceptable* if they cannot be supported or are defeated. Intuitively, an e-attack is a pair  $(B, a)$  where  $B$  groups together the arguments necessary to attack  $a$  and all the arguments necessary to support all those arguments. Then, acceptability is defined requiring defence against e-attacks instead of standard attacks. In this sense, an EBAF can be understood as a (possibly exponential in size) Dung's framework in which arguments are self-supporting sets and attacks are the e-attacks [21].

Let us start by defining the non-recursive framework that corresponds that corresponds to some EBAF with finite set of arguments.

**Definition 14.** Given an  $\mathbf{EBAF} = \langle \mathbf{A}, \mathbf{R}_a, \mathbf{R}_e \rangle$ , by  $\mathbf{AF}_{\mathbf{EBAF}} = \langle \mathbf{A}, \mathbf{K}, \mathbf{S}, \mathbf{s}, \mathbf{t}, \mathbf{P} \rangle$  we denote the argumentation framework where  $\mathbf{K}$  and  $\mathbf{S}$  are two (disjunct) sets with the same cardinality as  $\mathbf{R}_a$  and  $\mathbf{R}_e$ , respectively;  $\mathbf{P} = \mathbf{K} \cup \mathbf{S} \cup \{\eta\}$  and functions  $\mathbf{s}$  and  $\mathbf{t}$  map each attack and support name to their corresponding source and target,<sup>9</sup> that is, they satisfy:

$$\begin{aligned} \mathbf{R}_a &= \{ (\mathbf{s}(\alpha), \mathbf{t}(\alpha)) \mid \alpha \in \mathbf{K} \} \\ \mathbf{R}_e &= \{ (\mathbf{s}(\beta), \mathbf{t}(\beta)) \mid \beta \in \mathbf{S} \} \end{aligned}$$

Given a set  $E \subseteq \mathbf{A}$ , by  $\mathfrak{A}_E \stackrel{\text{def}}{=} \langle E, \mathbf{K}, \mathbf{S} \rangle$  we denote its corresponding structure.  $\square$

**Observation 2.** Since there are not attacks against other attacks or supports, every  $d$ -structure w.r.t. some  $\mathbf{AF}_{\mathbf{EBAF}}$  is of the form  $\mathfrak{A}_E$  for some set of arguments  $E \subseteq \mathbf{A}$ .  $\square$

In order to establish the existence of a one-to-one correspondence between finite EBAFs and non-recursive argumentation frameworks in our theory, let us define  $\mathbf{struct}_{\mathbf{EBAF}}(\cdot)$  as the function mapping any set of arguments  $E$  into the structure  $\mathfrak{A}_E = \langle E, \mathbf{K}, \mathbf{S} \rangle$ .

**Theorem 4.** Let  $\mathbf{EBAF}$  be some finite EBA framework. Then, the function  $\mathbf{struct}_{\mathbf{EBAF}}(\cdot)$  is a one-to-one correspondence between its self-supporting (resp. conflict-free, admissible, complete, preferred or stable) sets according to Definition 8 and the self-supporting (resp. conflict-free, admissible, complete, preferred or stable)  $d$ -structures of its corresponding framework  $\mathbf{AF}_{\mathbf{EBAF}}$ .  $\square$

<sup>9</sup>In other words, for a given  $(C, a) \in \mathbf{R}_a$ , if  $\alpha$  denotes the associated name in  $\mathbf{K}$ , we have  $\mathbf{s}(\alpha) = C$  and  $\mathbf{t}(\alpha) = a$ .

The above result holds for the finite case. That immediately rises the question whether this correspondence can be generalised to non-finite frameworks. The following example answers this question in a negative way.

**Example 9.** Let  $\mathbf{EBAF} = \langle \mathbf{A}, \mathbf{R}_a, \mathbf{R}_e \rangle$  be some EBAF with a set of arguments  $\mathbf{A} = \{\eta, a, b, c_1, c_2 \dots\}$ , a set of attacks  $\mathbf{R}_a = \{(\{a\}, b)\}$  and a set of supports

$$\begin{aligned} \mathbf{R}_e = & \{(\{\eta\}, b)\} \cup \{(\{\eta\}, c_1), (\{\eta\}, c_2), \dots\} \\ & \cup \{(\{c_1, c_2, \dots\}, a), (\{c_2, \dots\}, a), \dots\} \end{aligned}$$

Let  $E = \mathbf{A} \setminus \{a\}$  be a set of arguments. It is easy to see that every argument is supported according to Definition 5 and, thus, that  $a$  and all  $c_i$  are acceptable because there is no attack against them. This implies that  $b$  is not acceptable because it is attacked by  $a$  which is supported and not defeated and, thus, that  $E$  is not admissible. On the other hand, according to Definition 7, argument  $b$  is also acceptable w.r.t.  $E$ . Just note that, for every  $e$ -attack  $(C, b)$  against  $b$ , the set  $C$  must include  $a$  and infinitely many  $c_i$ 's and, thus, there is always some  $e$ -attack  $(C', b)$  against  $b$  with  $C' = C \setminus \{c_i\}$  and  $c_i \in C$ . Hence, there is no minimal  $e$ -attack against  $b$ , which immediately implies that  $b$  is acceptable and that  $E$  is admissible.  $\square$

It is worth to note that Example 9 can be also used to show that some usual results of abstract argumentation framework are not satisfied for non-finite EBAFs. In particular, the following example illustrates that neither the Fundamental Lemma nor the usual relations between semantics are satisfied:

*Example 9 (cont'd)* Note that  $a$  is acceptable w.r.t. the admissible set  $E$ , but  $E \cup \{a\}$  is not conflict-free (and, thus, not admissible) because  $a$  attacks  $b$ . This is a counterexample to the Fundamental Lemma. Furthermore, this also implies that  $E$  is a preferred set, though it is not a complete one, so the usual relations among semantics are not satisfied.  $\square$

## 7 Conclusions

In this work we have extended Dung's abstract argumentation framework with recursive attacks and supports. One of the essential characteristics of this extension is that semantics are given with respect to the notion of "valid attacks and supports" which respectively play a role analogous to attacks in Dung's frameworks and supports in Evidence-Based Argumentation (EBA). The bases for this extension were first settled in [9], where semantics for frameworks with recursive attacks without supports were studied. The notions of "grounded attack/support" and "valid attack/support" have been introduced in [8]. However, these notions have been encoded through a two-step translation into a meta-argumentation framework. In the first step, a meta-argument is associated to an attack, and a support relation is added from the source of the attack to the meta-argument. In the second step, a support relation is encoded by the addition of a new meta-argument and new attacks. So [8] uses a method for

flattening a recursive framework. As a consequence, extensions contain different kinds of argument. In contrast, we propose a theory where valid attacks remain explicit, and distinct from arguments, within the notion of structure.

It is worth mentioning that this extension is a conservative extension with respect to Dung’s approach (when d-structures are considered) and that we have proved a one-to-one correspondence with finite EBA frameworks. We have also shown that non-finite EBA frameworks do not satisfy the Fundamental Lemma nor the usual relations among semantics. In this sense, our approach is an alternative semantics for non-finite frameworks with evidence-based supports that satisfies these properties. In addition, with restricted frameworks without supports, we inherit, from [9], a one-to-one correspondence with AFRA-extensions [4] in the case of the complete, preferred and stable semantics.

For a better understanding of the recursive frameworks, future work should include the study of other semantics (stage, semi-stable, grounded and ideal), extending our approach by taking into account other bipolar interactions [13, 25], and enriching the translation proposed by [5, 7, 16, 22] from Dung’s framework into propositional logic and ASP, in order to capture RAF.

## References

- [1] L. Amgoud and C. Cayrol. A reasoning model based on the production of acceptable arguments. *Annals of Mathematics and Artificial Intelligence*, 34:197–216, 2002.
- [2] L. Amgoud, N. Maudet, and S. Parsons. Modelling dialogues using argumentation. In *Proc. of ICMAS*, pages 31–38, 2000.
- [3] R. Arisaka and K. Satoh. Voluntary manslaughter? a case study with meta-argumentation with supports. In S. Kurahashi, Y. Ohta, S. Arai, K. Satoh, and D. Bekki, editors, *New Frontiers in Artificial Intelligence. JSAI-isAI 2016. Lecture Notes in Computer Science, vol 10247*, pages 241–252. Springer, Cham, 2017.
- [4] P. Baroni, F. Cerutti, M. Giacomin, and G. Guida. AFRA: argumentation framework with recursive attacks. *Int. J. Approx. Reasoning*, 52(1):19–37, 2011.
- [5] P. Besnard and S. Doutre. Checking the acceptability of a set of arguments. In J. P. Delgrande and T. Schaub, editors, *10th International Workshop on Non-Monotonic Reasoning (NMR 2004), Whistler, Canada, June 6-8, 2004, Proceedings*, pages 59–64, 2004.
- [6] G. Boella, D. M. Gabbay, L. van der Torre, and S. Villata. Support in abstract argumentation. In *Proc. of COMMA*, pages 111–122, 2010.
- [7] J. L. Carballido, J. C. Nieves, and M. Osorio. Inferring preferred extensions by pstable semantics. *Inteligencia artificial: Revista Iberoamericana de Inteligencia Artificial*, 13(41):38–53, 2009.

- [8] C. Cayrol, A. Cohen, and M-C. Lagasquie-Schiex. Towards a new framework for recursive interactions in abstract bipolar argumentation. In *Proc. of COMMA*, pages 191–198, 2016.
- [9] C. Cayrol, J. Fandinno, L. Fariñas del Cerro, and M-C. Lagasquie-Schiex. Valid attacks in argumentation frameworks with recursive attacks. In *Commonsense reasoning*, 2017.
- [10] C. Cayrol and M-C. Lagasquie-Schiex. On the acceptability of arguments in bipolar argumentation frameworks. In Lluís Godo, editor, *Symbolic and Quantitative Approaches to Reasoning with Uncertainty, 8th European Conference, ECSQARU 2005, Barcelona, Spain, July 6-8, 2005, Proceedings*, volume 3571 of *Lecture Notes in Computer Science*, pages 378–389. Springer, 2005.
- [11] C. Cayrol and M-C. Lagasquie-Schiex. Bipolarity in argumentation graphs: towards a better understanding. *IJAR*, 54(7):876–899, 2013.
- [12] A. Cohen, S. Gottifredi, A. J. García, and G. R. Simari. A survey of different approaches to support in argumentation systems. *The Knowledge Engineering Review*, 29:513–550, 2014.
- [13] A. Cohen, S. Gottifredi, A. J. García, and G. R. Simari. An approach to abstract argumentation with recursive attack and support. *J. Applied Logic*, 13(4):509–533, 2015.
- [14] A. Cohen, S. Gottifredi, A. J. García, and G. R. Simari. On the acceptability semantics of argumentation frameworks with recursive attack and support. In *Proc. of COMMA*, pages 231–242, 2016.
- [15] P. M. Dung. On the acceptability of arguments and its fundamental role in nonmonotonic reasoning, logic programming and n-person games. *Artif. Intell.*, 77(2):321–358, 1995.
- [16] U. Egly, S. A. Gaggl, and S. Woltran. Answer-set programming encodings for argumentation frameworks. *Argument & Computation*, 1(2):147–177, 2010.
- [17] Nikos I. Karacapilidis and Dimitris Papadias. Computer supported argumentation and collaborative decision making: the HERMES system. *Inf. Syst.*, 26(4):259–277, 2001.
- [18] F. Nouioua and V. Risch. Bipolar argumentation frameworks with specialized supports. In *Proc. of ICTAI*, pages 215–218. IEEE Computer Society, 2010.
- [19] F. Nouioua and V. Risch. Argumentation frameworks with necessities. In *Proc. of SUM*, pages 163–176, 2011.

- [20] N. Oren and T.J. Norman. Semantics for evidence-based argumentation. In Philippe Besnard, Sylvie Doutre, and Anthony Hunter, editors, *Computational Models of Argument: Proceedings of COMMA 2008, Toulouse, France, May 28-30, 2008.*, volume 172 of *Frontiers in Artificial Intelligence and Applications*, pages 276–284. IOS Press, 2008.
- [21] N. Oren, C. Reed, and M. Luck. Moving between argumentation frameworks. In Pietro Baroni, Federico Cerutti, Massimiliano Giacomin, and Guillermo Ricardo Simari, editors, *Computational Models of Argument: Proceedings of COMMA 2010, Desenzano del Garda, Italy, September 8-10, 2010.*, volume 216 of *Frontiers in Artificial Intelligence and Applications*, pages 379–390. IOS Press, 2010.
- [22] M. Osorio, J. C. Nieves, and A. Santoyo. Complete extensions as clark’s completion semantics. In *Proc. of the Mexican International Conference on Computer Science*, pages 81–88, 2013.
- [23] S. Polberg and N. Oren. Revisiting support in abstract argumentation systems. Technical report, TU Wien, Institut for Informatics, 2014.
- [24] B. Verheij. Deflog: on the logical interpretation of prima facie justified assumptions. *J. Log. Comput.*, 13(3):319–346, 2003.
- [25] S. Villata, G. Boella, D. M. Gabbay, and L. van der Torre. Modelling defeasible and prioritized support in bipolar argumentation. *Annals of Maths and AI*, 66(1-4):163–197, 2012.

## A Proofs

This appendix is given for review purposes only and it is not part of the paper.

**Lemma A.1.** *Let  $\mathbf{AF} = \langle \mathbf{A}, \mathbf{K}, \mathbf{S}, \mathbf{s}, \mathbf{t}, \mathbf{P} \rangle$  be some framework and  $\mathfrak{A}, \mathfrak{A}'$  be two structures such that  $\mathfrak{A} \sqsubseteq \mathfrak{A}'$ . Then,  $Def_X(\mathfrak{A}) \subseteq Def_X(\mathfrak{A}')$  with  $X \in \{\mathbf{A}, \mathbf{K}, \mathbf{S}\}$ . Furthermore,  $Sup(\mathfrak{A}) \subseteq Sup(\mathfrak{A}')$  also holds.  $\square$*

*Proof.*  $\mathfrak{A} \sqsubseteq \mathfrak{A}'$  implies that  $E \subseteq E'$  and  $\Gamma \subseteq \Gamma'$ . So due to definition of  $Def_X(\mathfrak{A})$ , it is obvious that  $Def_X(\mathfrak{A}) \subseteq Def_X(\mathfrak{A}')$ . In the case of supports,  $\mathfrak{A} \sqsubseteq \mathfrak{A}'$  implies  $E \subseteq E'$ , and  $\Delta \subseteq \Delta'$  and the proof just follows by induction.  $\square$

**Lemma A.2.** *Let  $\mathbf{AF} = \langle \mathbf{A}, \mathbf{K}, \mathbf{S}, \mathbf{s}, \mathbf{t}, \mathbf{P} \rangle$  be some framework and  $\mathfrak{A} = \langle E, \Gamma, \Delta \rangle$  be a conflict-free self-supporting structure. Then,  $Acc(\mathfrak{A}) \cap Def(\mathfrak{A}) = \emptyset$ .  $\square$*

*Proof.* Assume that  $x \in (Acc(\mathfrak{A}) \cap Def(\mathfrak{A}))$ . Then, there is  $\alpha \in \Gamma$  with  $\mathbf{s}(\alpha) \subseteq E$  and  $t(\alpha) = x$ . Since  $x \in Acc(\mathfrak{A})$ , it follows that either  $\mathbf{s}(\alpha) \cap UnAcc(\mathfrak{A}) \neq \emptyset$  or  $\alpha \in UnAcc(\mathfrak{A})$  holds. Furthermore, since  $\mathfrak{A}$  is conflict-free, it also follows that  $\alpha \in \Gamma \subseteq \overline{Def(\mathfrak{A})}$  and  $\mathbf{s}(\alpha) \subseteq E \subseteq \overline{Def(\mathfrak{A})}$ . In its turn, this implies that either  $\mathbf{s}(\alpha) \cap \overline{Sup(\mathfrak{A}')} \neq \emptyset$  or  $\alpha \notin \overline{Sup(\mathfrak{A}'')}$  with  $\mathfrak{A}' = \langle \overline{Def_{\mathbf{A}}(\mathfrak{A})}, \mathbf{K}, \overline{Def_{\mathbf{S}}(\mathfrak{A})} \rangle$ . Note that, since  $\mathfrak{A}$  is conflict-free, it follows that  $\mathfrak{A} \sqsubseteq \mathfrak{A}'$  and, from Lemma A.1, this implies that  $\mathbf{s}(\alpha) \cap \overline{Sup(\mathfrak{A}')} \neq \emptyset$  or  $\alpha \notin \overline{Sup(\mathfrak{A}'')}$ . Both of which are in contradiction with the fact that  $\mathfrak{A}$  is self-supporting.  $\square$

**Definition 15.** *Let us denote by  $CSup(\mathfrak{A}) \stackrel{\text{def}}{=} \overline{Sup(\mathfrak{A}'')}$  the set of supportable elements wrt  $\mathfrak{A}$ , where  $\mathfrak{A}' = \langle \overline{Def_{\mathbf{A}}(\mathfrak{A})}, \mathbf{K}, \overline{Def_{\mathbf{S}}(\mathfrak{A})} \rangle$ .  $\square$*

**Lemma A.3.** *Let  $\mathbf{AF} = \langle \mathbf{A}, \mathbf{K}, \mathbf{S}, \mathbf{s}, \mathbf{t}, \mathbf{P} \rangle$  be some framework and  $\mathfrak{A}, \mathfrak{A}'$  be two structures such that  $\mathfrak{A} \sqsubseteq \mathfrak{A}'$ . Then,  $CSup(\mathfrak{A}) \supseteq CSup(\mathfrak{A}')$ .  $\square$*

*Proof.* By definition, we have  $CSup(\mathfrak{A}) = Sup(\mathfrak{A}_1)$  and  $CSup(\mathfrak{A}') = Sup(\mathfrak{A}_2)$  with

$$\begin{aligned} \mathfrak{A}_1 &= \langle \overline{Def_{\mathbf{A}}(\mathfrak{A})}, \mathbf{K}, \overline{Def_{\mathbf{S}}(\mathfrak{A})} \rangle \\ \mathfrak{A}_2 &= \langle \overline{Def_{\mathbf{A}}(\mathfrak{A}')}, \mathbf{K}, \overline{Def_{\mathbf{S}}(\mathfrak{A}')} \rangle \end{aligned}$$

From Lemma A.1 and  $\mathfrak{A} \sqsubseteq \mathfrak{A}'$ , we get  $Def_X(\mathfrak{A}) \subseteq Def_X(\mathfrak{A}')$  with  $X \in \{\mathbf{A}, \mathbf{K}, \mathbf{S}\}$  which implies  $\overline{Def_X(\mathfrak{A})} \supseteq \overline{Def_X(\mathfrak{A}'')}$ . Hence, we have that  $\mathfrak{A}_1 \supseteq \mathfrak{A}_2$  and, from Lemma A.1 again, it follows that  $Sup(\mathfrak{A}_1) \supseteq Sup(\mathfrak{A}_2)$  and  $CSup(\mathfrak{A}) \supseteq CSup(\mathfrak{A}')$   $\square$

**Lemma A.4.** *Let  $\mathbf{AF} = \langle \mathbf{A}, \mathbf{K}, \mathbf{S}, \mathbf{s}, \mathbf{t}, \mathbf{P} \rangle$  be some framework and  $\mathfrak{A}, \mathfrak{A}'$  be two structures such that  $\mathfrak{A} \sqsubseteq \mathfrak{A}'$ . Then,  $UnAcc(\mathfrak{A}) \subseteq UnAcc(\mathfrak{A}')$ .  $\square$*

*Proof.* By definition, we have that

$$\begin{aligned} UnAcc(\mathfrak{A}) &\stackrel{\text{def}}{=} Def(\mathfrak{A}) \cup \overline{CSup(\mathfrak{A})} \\ UnAcc(\mathfrak{A}') &\stackrel{\text{def}}{=} Def(\mathfrak{A}') \cup \overline{CSup(\mathfrak{A}')} \end{aligned}$$

From Lemma A.1 and  $\mathfrak{A} \sqsubseteq \mathfrak{A}'$ , we get  $Def(\mathfrak{A}) \subseteq Def(\mathfrak{A}')$ . In addition, from Lemma A.3, we get  $CSup(\mathfrak{A}) \supseteq CSup(\mathfrak{A}')$  which implies  $\overline{CSup(\mathfrak{A})} \subseteq \overline{CSup(\mathfrak{A}'')}$ . Hence, the lemma holds.  $\square$

**Lemma A.5.** *Let  $\mathbf{AF} = \langle \mathbf{A}, \mathbf{K}, \mathbf{S}, \mathbf{s}, \mathbf{t}, \mathbf{P} \rangle$  be some framework and  $\mathfrak{A}, \mathfrak{A}'$  be two structures such that  $\mathfrak{A} \sqsubseteq \mathfrak{A}'$ . Then, it follows that  $Acc(\mathfrak{A}) \subseteq Acc(\mathfrak{A}')$ .  $\square$*

*Proof.* Let  $x \in Acc(\mathfrak{A})$ . Then,  $x \in Sup(\mathfrak{A}) \subseteq Sup(\mathfrak{A}')$  (Lemma A.1). Pick any  $\alpha \in \mathbf{K}$  with  $\mathbf{t}(\alpha) = x$ . Since  $x \in Acc(\mathfrak{A})$ , it follows that either  $\mathbf{s}(\alpha) \cap UnAcc(\mathfrak{A}) \neq \emptyset$  or  $\alpha \in UnAcc(\mathfrak{A})$  holds. Furthermore, from Lem. A.4, we have  $UnAcc(\mathfrak{A}) \subseteq UnAcc(\mathfrak{A}')$  which, in its turn, implies that  $x \in Acc(\mathfrak{A}')$  follows.  $\square$

**Lemma A.6.** *Every admissible structure is self-supporting.*  $\square$

*Proof.* By definition of admissible structure and acceptability, we have that every admissible structure  $\mathfrak{A}$  satisfies  $E \cup \Gamma \cup \Delta \subseteq Acc(\mathfrak{A}) \subseteq Sup(\mathfrak{A})$  and, thus, every admissible structure is also self-supporting.  $\square$

**Lemma A.7.** *Any conflict-free self-supporting structure  $\mathfrak{A}$  satisfies:  $Acc(\mathfrak{A}) \subseteq \overline{UnAcc(\mathfrak{A})} \subseteq \overline{Def(\mathfrak{A})}$ .*  $\square$

*Proof.* By definition, we have that

$$\begin{aligned} \overline{UnAcc(\mathfrak{A})} &= \overline{(Def(\mathfrak{A}) \cup \overline{CSup(\mathfrak{A})})} \\ &= \overline{Def(\mathfrak{A})} \cap CSup(\mathfrak{A}) \end{aligned}$$

Hence, due to Lemma A.2, it is enough to show that  $Acc(\mathfrak{A}) \subseteq \overline{CSup(\mathfrak{A})}$ .

By definition,  $CSup(\mathfrak{A}) = Sup(\mathfrak{A}')$  where  $\mathfrak{A}' = \langle \overline{Def_{\mathbf{A}}(\mathfrak{A})}, \mathbf{K}, \overline{Def_{\mathbf{S}}(\mathfrak{A})} \rangle$ . As  $\mathfrak{A}$  is conflict-free,  $\mathfrak{A} \subseteq \mathfrak{A}'$  so, from Lemma A.1, we have that  $Sup(\mathfrak{A}) \subseteq Sup(\mathfrak{A}')$ . Moreover, by definition we have  $Acc(\mathfrak{A}) \subseteq Sup(\mathfrak{A})$ . So  $Acc(\mathfrak{A}) \subseteq Sup(\mathfrak{A}') = CSup(\mathfrak{A})$ .  $\square$

**Lemma A.8.** *Let  $\mathbf{AF} = \langle \mathbf{A}, \mathbf{K}, \mathbf{S}, \mathbf{s}, \mathbf{t}, \mathbf{P} \rangle$  be some framework and  $\mathfrak{A} = \langle E, \Gamma, \Delta \rangle$  be some an admissible structure. Then, any element  $x \in Acc(\mathfrak{A})$  satisfies that  $\mathfrak{A}' = \mathfrak{A} \cup \{x\}$  is conflict-free.*

*Proof.* Let us define  $E' \stackrel{\text{def}}{=} E \cup \{x\}$  if  $x \in \mathbf{A}$ ,  $E' \stackrel{\text{def}}{=} E$  otherwise. Similarly,  $\Gamma' \stackrel{\text{def}}{=} \Gamma \cup \{x\}$  if  $x \in \mathbf{A}$ ,  $\Gamma' \stackrel{\text{def}}{=} \Gamma$  otherwise; and  $\Delta' \stackrel{\text{def}}{=} \Delta \cup \{x\}$  if  $x \in \mathbf{A}$ ,  $\Delta' \stackrel{\text{def}}{=} \Delta$  otherwise. Since  $\mathfrak{A}$  is admissible and  $x \in Acc(\mathfrak{A})$ , it is clear that  $(E' \cup \Gamma' \cup \Delta') \subseteq Acc(\mathfrak{A})$ . Suppose, for the sake of contradiction, that  $\mathfrak{A}'$  is not conflict-free. Then, there is some attack  $\beta \in \Gamma'$  such that  $\mathbf{t}(\beta) \in (E' \cup \Gamma' \cup \Delta')$  and  $\mathbf{s}(\beta) \subseteq E'$ . Hence,  $\mathbf{t}(\beta) \in Acc(\mathfrak{A})$  which, in its turn, implies that either  $\beta \in UnAcc(\mathfrak{A})$  or  $\mathbf{s}(\beta) \cap UnAcc(\mathfrak{A}) \neq \emptyset$  must hold. As  $\mathfrak{A}$  is admissible, it is self-supporting (Lem. A.6), so Lemma A.7 can be applied and from the fact that  $\Gamma' \subseteq Acc(\mathfrak{A})$ , it follows that

$$\beta \in \Gamma' \subseteq Acc(\mathfrak{A}) \subseteq \overline{UnAcc(\mathfrak{A})} \quad (5)$$

which is a contradiction with  $\beta \in UnAcc(\mathfrak{A})$ . Furthermore, since  $E' \subseteq Acc(\mathfrak{A})$  and, thus

$$\mathbf{s}(\beta) \subseteq E' \subseteq Acc(\mathfrak{A}) \subseteq \overline{UnAcc(\mathfrak{A})} \quad (6)$$

which is a contradiction with  $\mathbf{s}(\beta) \cap UnAcc(\mathfrak{A}) \neq \emptyset$ . Consequently,  $\mathfrak{A}'$  is conflict-free.  $\square$



## A.1 Proofs of Section 3

**Lemma 1** (Fundamental Lemma). *Let  $\mathfrak{A} = \langle E, \Gamma, \Delta \rangle$  be an admissible structure and  $x, y \in \text{Acc}(\mathfrak{A})$  be any pair of acceptable elements. Then,<sup>10</sup> (i)  $\mathfrak{A}' = \mathfrak{A} \cup \{x\}$  is an admissible structure, and (ii)  $y \in \text{Acc}(\mathfrak{A}')$ .  $\square$*

*Proof.* From Lem. A.8, we know that  $\mathfrak{A}' = \langle E', \Gamma', \Delta' \rangle$  is conflict-free. Furthermore, since  $\mathfrak{A}$  is admissible and  $x \in \text{Acc}(\mathfrak{A})$ ,  $(E \cup \Gamma \cup \Delta \cup \{x\}) \subseteq \text{Acc}(\mathfrak{A})$ . Then, since  $\mathfrak{A} \sqsubseteq \mathfrak{A}'$ , Lem. A.5 implies that

$$(E' \cup \Gamma' \cup \Delta') = (E \cup \Gamma \cup \Delta \cup \{x\}) \subseteq \text{Acc}(\mathfrak{A}) \subseteq \text{Acc}(\mathfrak{A}')$$

and thus, that  $\mathfrak{A}'$  is admissible and  $y \in \text{Acc}(\mathfrak{A}')$ .  $\square$

**Lemma A.9.** *Let  $\mathbf{AF} = \langle \mathbf{A}, \mathbf{K}, \mathbf{S}, \mathbf{s}, \mathbf{t}, \mathbf{P} \rangle$  be some framework and  $\mathfrak{A}_0 \sqsubseteq \mathfrak{A}_1 \sqsubseteq \dots$  be some sequence of conflict-free structures s.t.  $\mathfrak{A}_i = \langle E_i, \Gamma_i, \Delta_i \rangle$ . Let us define  $\mathfrak{A} = \langle \bigcup_{0 \leq i} E_i, \bigcup_{0 \leq i} \Gamma_i, \bigcup_{0 \leq i} \Delta_i \rangle$ . Then,  $\mathfrak{A}$  is conflict-free.  $\square$*

*Proof.* Suppose, for the sake of contradiction, that  $\mathfrak{A}$  is not conflict-free. Then,  $(Y \cap \text{Def}_X(\mathfrak{A})) \neq \emptyset$  for some  $(Y, X) \in \{(E, \mathbf{A}), (\Gamma, \mathbf{K}), (\Delta, \mathbf{S})\}$  (with  $E = \bigcup_{0 \leq i} E_i$  and  $\Gamma = \bigcup_{0 \leq i} \Gamma_i$  and  $\Delta = \bigcup_{0 \leq i} \Delta_i$ ). Pick any  $x \in (Y \cap \text{Def}_X(\mathfrak{A}))$ . Then,  $x \in \text{Def}_X(\mathfrak{A})$  implies that there is  $\alpha \in \Gamma$  such that  $\mathbf{t}(\alpha) = x$  and  $\mathbf{s}(\alpha) \subseteq E$ . Hence, there is  $0 \leq i$  such that  $\alpha \in \Gamma_i$  and  $0 \leq j$  such that  $\mathbf{s}(\alpha) \subseteq E_j$ . Let  $k = \max\{i, j\}$ . Then,  $\alpha \in \Gamma_k$  and  $\mathbf{s}(\alpha) \subseteq E_k$  which means that  $x \in \text{Def}_X(\mathfrak{A}_k)$ . Moreover, there is  $0 \leq l$  such that  $x \in Y_l$ . Let  $m = \max\{k, l\}$ . Then,  $x \in Y_m$  and from Lem. A.1, we have that  $\text{Def}_X(\mathfrak{A}_k) \subseteq \text{Def}_X(\mathfrak{A}_m)$ . That is in contradiction with the fact that  $\mathfrak{A}_m$  is conflict-free. Hence,  $\mathfrak{A}$  must be conflict-free.  $\square$

**Proposition 1.** *The set of all admissible structures forms a complete partial order with respect to  $\sqsubseteq$ . Furthermore, for every admissible structure  $\mathfrak{A}$ , there exists a preferred one  $\mathfrak{A}'$  such that  $\mathfrak{A} \sqsubseteq \mathfrak{A}'$ .  $\square$*

*Proof.* First note that  $\langle \emptyset, \emptyset, \emptyset \rangle$  is always admissible and that  $\langle \emptyset, \emptyset, \emptyset \rangle \sqsubseteq \mathfrak{A}$  for any structure  $\mathfrak{A}$ . Furthermore, for every chain  $\mathfrak{A}_0 \sqsubseteq \mathfrak{A}_1 \sqsubseteq \dots$  with  $\mathfrak{A}_i = \langle E_i, \Gamma_i, \Delta_i \rangle$ , it follows that  $\mathfrak{A}_i \sqsubseteq \mathfrak{A}$  with  $\mathfrak{A} = \langle E, \Gamma, \Delta \rangle$  such that  $E = \bigcup_{0 \leq i} E_i$  and  $\Gamma = \bigcup_{0 \leq i} \Gamma_i$  and  $\Delta = \bigcup_{0 \leq i} \Delta_i$ . From Lem. A.9, it follows that  $\mathfrak{A}$  is conflict-free. Let us show now that  $\mathfrak{A}$  is admissible, that is, that every element in  $\mathfrak{A}$  is acceptable wrt  $\mathfrak{A}$ . Pick  $x \in (E \cup \Gamma \cup \Delta)$  and any attack  $\beta \in \mathbf{K}$  with  $\mathbf{t}(\beta) = x$ . Then,  $x \in (E_i \cup \Gamma_i \cup \Delta_i)$  for some  $0 \leq i$ . Since  $\mathfrak{A}_i$  is admissible, this implies that  $x \in \text{Acc}(\mathfrak{A}_i)$  and, from Lemma A.5 and the fact that  $\mathfrak{A}_i \sqsubseteq \mathfrak{A}$ , we get  $x \in \text{Acc}(\mathfrak{A}_i) \subseteq \text{Acc}(\mathfrak{A})$  and, thus,  $\mathfrak{A}$  is admissible.

To show that, for every admissible structure  $\mathfrak{A}$ , there is some preferred structure  $\mathfrak{A}'$  such that  $\mathfrak{A} \sqsubseteq \mathfrak{A}'$ , suppose, for the sake of contradiction, that there is some admissible structure  $\mathfrak{A}$  such that no preferred structure  $\mathfrak{A}'$  with  $\mathfrak{A} \sqsubseteq \mathfrak{A}'$  exists. Then, there must be some infinite chain  $\mathfrak{A} \sqsubseteq \mathfrak{A}_1 \sqsubseteq \mathfrak{A}_2 \sqsubseteq \dots$ . However, as shown above, it follows that there is some  $\mathfrak{A}$  such that  $\mathfrak{A}_i \sqsubseteq \mathfrak{A}$  for all  $\mathfrak{A}_i$  and, thus,  $\mathfrak{A}$  is a preferred structure.  $\square$

<sup>10</sup>By abuse of notation, we write  $\mathfrak{A} \cup T$  instead of  $\langle E \cup (T \cap \mathbf{A}), \Gamma \cup (T \cap \mathbf{K}), \Delta \cup (T \cap \mathbf{S}) \rangle$  with  $T \subseteq (\mathbf{A} \cup \mathbf{K} \cup \mathbf{S})$ .

**Lemma A.10.** *Every stable structure is conflict-free.*  $\square$

*Proof.* Let  $\mathfrak{A} = \langle E, \Gamma, \Delta \rangle$  be a stable structure. By definition, we have  $(E \cup \Gamma \cup \Delta) = \overline{UnAcc(\mathfrak{A})}$ , with  $UnAcc(\mathfrak{A}) = Def(\mathfrak{A}) \cup Sup(\mathfrak{A})$ . So,  $\overline{UnAcc(\mathfrak{A})} \subseteq Def(\mathfrak{A})$ . So  $(E \cup \Gamma \cup \Delta) \subseteq \overline{Def(\mathfrak{A})}$ , hence  $\mathfrak{A}$  is conflict-free.  $\square$

**Lemma A.11.** *Let  $\mathbf{AF} = \langle \mathbf{A}, \mathbf{K}, \mathbf{S}, \mathbf{s}, \mathbf{t}, \mathbf{P} \rangle$  be some framework,  $\mathfrak{A} = \langle E, \Gamma, \Delta \rangle$  be some structure. Then,  $x \in Sup(\mathfrak{A})$  iff  $x \in Sup(\mathfrak{A} \setminus \{x\})$ .*  $\square$

*Proof.* The if direction follows directly from Lemma A.1. For the only if direction, by definition,  $x \in Sup(\mathfrak{A})$  implies that either  $x \in \mathbf{P}$  or there exists some support  $\alpha \in (\Delta \cap Sup(\mathfrak{A} \setminus \{x\}))$  such that  $\mathbf{s}(\alpha) \subseteq (E \cap Sup(\mathfrak{A} \setminus \{x\}))$  and  $\mathbf{t}(\alpha) = x$ . The former directly implies that  $x \in Sup(\mathfrak{A} \setminus \{x\})$ , so we assume without loss of generality the latter.

In case that  $x = \alpha$ , then  $x \in Sup(\mathfrak{A} \setminus \{x\})$  follows directly from the above fact  $\alpha \in (\Delta \cap Sup(\mathfrak{A} \setminus \{x\}))$ . Similarly, in case that  $x \in \mathbf{s}(\alpha)$ , then it follows directly from  $\mathbf{s}(\alpha) \subseteq (E \cap Sup(\mathfrak{A} \setminus \{x\}))$ . Hence, we also assume without loss of generality that  $x \notin (\mathbf{s}(\alpha) \cup \{\alpha\})$ . Hence,  $\alpha \in (\Delta \setminus \{x\})$  and  $\mathbf{s}(\alpha) \subseteq (E \setminus \{x\})$ . Furthermore, it is clear that  $(\mathfrak{A} \setminus \{x\}) \setminus \{x\} = \mathfrak{A} \setminus \{x\}$  and, thus, this implies that  $x \in Sup(\mathfrak{A} \setminus \{x\})$  holds.  $\square$

**Lemma A.12.** *Let  $\mathfrak{A} = \langle E, \Gamma, \Delta \rangle$  be a stable structure and  $\mathfrak{A}_2 = \langle E_2, \Gamma_2, \Delta_2 \rangle$  be a structure such that  $(E_2 \cup \Gamma_2 \cup \Delta_2) \subseteq \overline{Def(\mathfrak{A})}$ . Let  $\mathfrak{A}_1$  be the structure defined as  $\mathfrak{A}_2 \cap \mathfrak{A}$  (that is  $X_1 = X_2 \cap X$  with  $X \in \{E, \Gamma, \Delta\}$ ). Then,  $(E_2 \cup \Gamma_2 \cup \Delta_2) \cap Sup(\mathfrak{A}_2) \subseteq (E_1 \cup \Gamma_1 \cup \Delta_1)$ .*  $\square$

*Proof.* Let  $\mathfrak{A}' = \langle \overline{Def_{\mathbf{A}}(\mathfrak{A})}, \mathbf{K}, \overline{Def_{\mathbf{S}}(\mathfrak{A})} \rangle$ . We have  $\mathfrak{A}_2 \sqsubseteq \mathfrak{A}'$ . Let  $x \in (E_2 \cup \Gamma_2 \cup \Delta_2) \cap Sup(\mathfrak{A}_2)$ . As  $x \in Sup(\mathfrak{A}_2)$  we have  $x \in Sup(\mathfrak{A}')$  (Lemma A.1). Note also that we have  $x \in (E_2 \cup \Gamma_2 \cup \Delta_2) \subseteq \overline{Def(\mathfrak{A})}$  and, thus,

$$x \in \overline{Def(\mathfrak{A})} \cap Sup(\mathfrak{A}') = \overline{UnAcc(\mathfrak{A})} = (E \cup \Gamma \cup \Delta)$$

Then, since  $x \in (E \cup \Gamma \cup \Delta)$  and  $x \in (E_2 \cup \Gamma_2 \cup \Delta_2)$ , by definition of  $\mathfrak{A}_1$ , it follows that  $x \in (E_1 \cup \Gamma_1 \cup \Delta_1)$ . Thus we have proved that  $(E_2 \cup \Gamma_2 \cup \Delta_2) \cap Sup(\mathfrak{A}_2) \subseteq (E_1 \cup \Gamma_1 \cup \Delta_1)$ .  $\square$

**Lemma A.13.** *Let  $\mathfrak{A} = \langle E, \Gamma, \Delta \rangle$  be a stable structure and  $\mathfrak{A}_2 = \langle E_2, \Gamma_2, \Delta_2 \rangle$  and  $\mathfrak{A}_3 = \langle E_3, \Gamma_3, \Delta_3 \rangle$  be two structures such that  $(E_3 \cup \Gamma_3 \cup \Delta_3) \subseteq \overline{Def(\mathfrak{A})}$  and  $\mathfrak{A} \sqsubseteq \mathfrak{A}_3$  and  $\mathfrak{A}_2 \sqsubseteq \mathfrak{A}_3$ . Let  $\mathfrak{A}_1$  be the structure defined as  $\mathfrak{A}_2 \cap \mathfrak{A}$  (that is  $X_1 = X_2 \cap X$  with  $X \in \{E, \Gamma, \Delta\}$ ). Then,  $(E_2 \cup \Gamma_2 \cup \Delta_2) \cap Sup(\mathfrak{A}_2) \subseteq (E_1 \cup \Gamma_1 \cup \Delta_1) \cap Sup(\mathfrak{A}_1)$ .*  $\square$

*Proof.* This is trivially true if  $\mathfrak{A}_2 = \langle \emptyset, \emptyset, \emptyset \rangle$ . Otherwise, we proceed by induction assuming the hypothesis is true for all structures  $\mathfrak{A}'_2 \sqsubset \mathfrak{A}_2$ . Pick any  $x \in (E_2 \cup \Gamma_2 \cup \Delta_2) \cap Sup(\mathfrak{A}_2)$ . First note that, from Lemma A.12, this directly implies that  $x \in (E_1 \cup \Gamma_1 \cup \Delta_1)$ .

Furthermore, from Lemma A.11,  $x \in Sup(\mathfrak{A}_2)$  implies  $x \in Sup(\mathfrak{A}_2 \setminus \{x\})$  which implies that there is some support  $\alpha \in \Delta_2 \setminus \{x\} \cap Sup(\mathfrak{A}_2 \setminus \{x\})$  such that  $\mathbf{t}(\alpha) = x$  and  $\mathbf{s}(\alpha) \subseteq E_2 \setminus \{x\} \cap Sup(\mathfrak{A}_2 \setminus \{x\})$ .

In addition,  $x \in (E_2 \cup \Gamma_2 \cup \Delta_2)$  implies that  $\mathfrak{A}_2 \setminus \{x\} \sqsubset \mathfrak{A}_2$ .

Hence, by induction hypothesis with  $\mathfrak{A}'_2 = \mathfrak{A}_2 \setminus \{x\}$ , we obtain  $(E'_2 \cup \Gamma'_2 \cup \Delta'_2) \cap Sup(\mathfrak{A}'_2) \subseteq (E'_1 \cup \Gamma'_1 \cup \Delta'_1) \cap Sup(\mathfrak{A}'_1)$  where  $\mathfrak{A}'_1 = \langle E', \Gamma', \Delta' \rangle$  is the structure defined as  $\mathfrak{A}'_2 \cap \mathfrak{A}$ . So, we have  $\mathfrak{A}'_1 = \mathfrak{A}_1 \setminus \{x\}$  and

$$\alpha \in Sup(\mathfrak{A}_1 \setminus \{x\}) \quad (7)$$

$$\mathbf{s}(\alpha) \subseteq Sup(\mathfrak{A}_1 \setminus \{x\}) \quad (8)$$

Moreover, from Lemma A.12,  $\alpha \in \Delta_2 \setminus \{x\} \cap Sup(\mathfrak{A}_2 \setminus \{x\})$  implies

$$\alpha \in \Delta_1 \setminus \{x\} \subseteq \Delta_1$$

From an analogous reasoning, we get that  $\mathbf{s}(\alpha) \subseteq E_1$ . This plus (7-8) imply

$$\begin{aligned} \alpha &\in \Delta_1 \cap Sup(\mathfrak{A}_1 \setminus \{x\}) \\ \mathbf{s}(\alpha) &\subseteq E_1 \cap Sup(\mathfrak{A}_1 \setminus \{x\}) \end{aligned}$$

and  $x \in Sup(\mathfrak{A}_1)$ . Hence,  $(E_2 \cup \Gamma_2 \cup \Delta_2) \cap Sup(\mathfrak{A}_2) \subseteq (E_1 \cup \Gamma_1 \cup \Delta_1) \cap Sup(\mathfrak{A}_1)$  follows. □

**Lemma A.14.** *Every stable structure is self-supporting.* □

*Proof.* Let  $\mathfrak{A} = \langle E, \Gamma, \Delta \rangle$  be a stable structure. From Definition 10, we have that

$$(E \cup \Gamma \cup \Delta) = \overline{UnAcc(\mathfrak{A})} = Sup(\mathfrak{A}') \cap \overline{Def(\mathfrak{A})} = Sup(\mathfrak{A}'') \cap \overline{Def(\mathfrak{A})}$$

with  $\mathfrak{A}' = \langle \overline{Def_{\mathbf{A}}(\mathfrak{A})}, \mathbf{K}, \overline{Def_{\mathbf{S}}(\mathfrak{A})} \rangle$  and  $\mathfrak{A}'' = \langle \overline{Def_{\mathbf{A}}(\mathfrak{A})}, \overline{Def_{\mathbf{K}}(\mathfrak{A})}, \overline{Def_{\mathbf{S}}(\mathfrak{A})} \rangle$ . Note that  $Sup(\mathfrak{A}') = Sup(\mathfrak{A}'')$  because supported elements do not depend on attacks. Obviously, we have  $\mathfrak{A}'' \subseteq \mathfrak{A}'$ . And, since  $\mathfrak{A}$  is stable (and thus conflict-free), we also have  $\mathfrak{A} \sqsubseteq \mathfrak{A}''$ .

This implies  $(E \cup \Gamma \cup \Delta) \subseteq (\overline{Def_{\mathbf{A}}(\mathfrak{A})} \cup \overline{Def_{\mathbf{K}}(\mathfrak{A})} \cup \overline{Def_{\mathbf{S}}(\mathfrak{A})}) \cap Sup(\mathfrak{A}'')$ . Then, Lemma A.13 can be applied with  $\mathfrak{A}_2 = \mathfrak{A}_3 = \mathfrak{A}''$  and  $\mathfrak{A}_1 = (\mathfrak{A}_2 \cap \mathfrak{A}) = \mathfrak{A}$  (since  $\mathfrak{A} \sqsubseteq \mathfrak{A}''$ ). Thus we obtain

$$\begin{aligned} (E \cup \Gamma \cup \Delta) &\subseteq (\overline{Def_{\mathbf{A}}(\mathfrak{A})} \cup \overline{Def_{\mathbf{K}}(\mathfrak{A})} \cup \overline{Def_{\mathbf{S}}(\mathfrak{A})}) \cap Sup(\mathfrak{A}'') \\ &\subseteq (E \cup \Gamma \cup \Delta) \cap Sup(\mathfrak{A}) \end{aligned}$$

and, thus,  $(E \cup \Gamma \cup \Delta) \subseteq Sup(\mathfrak{A})$ . □

**Theorem 2.** *The following assertions hold:*

- i) every admissible structure is also self-supporting,*

- ii) every complete structure is also admissible,
- iii) every preferred structure is also complete, and
- iv) every stable structure is also preferred. □

*Proof.* Then...

1. Directly from Lemma A.6.
2. By definition of a complete structure.
3. By definition, every preferred structure  $\mathfrak{A} = \langle E, \Gamma, \Delta \rangle$  is also admissible. Hence, to show that  $\mathfrak{A}$  is complete, it enough to prove that  $Acc(\mathfrak{A}) \subseteq (E \cup \Gamma \cup \Delta)$ . Pick any  $x \in Acc(\mathfrak{A})$ . Then, from Lem. 1 (Fundamental Lemma) it follows that  $\mathfrak{A}' = (\mathfrak{A} \cup \{x\})$  is also admissible and that  $\mathfrak{A} \sqsubseteq \mathfrak{A}'$ . Furthermore, since  $\mathfrak{A}$  is preferred, it follows that  $\mathfrak{A}$  is a  $\sqsubseteq$ -maximal admissible structure and, thus,  $\mathfrak{A} \sqsubseteq \mathfrak{A}'$  implies that  $\mathfrak{A} = \mathfrak{A}'$ . Hence,  $x \in (E \cup \Gamma \cup \Delta)$  holds and, thus, it follows that  $Acc(\mathfrak{A}) \subseteq (E \cup \Gamma \cup \Delta)$  and that  $\mathfrak{A}$  is complete.
4. Assume that  $\mathfrak{A}$  is a stable structure. We have to prove that  $\mathfrak{A}$  is a  $\sqsubseteq$ -maximal admissible structure.

We first prove that  $\mathfrak{A}$  is admissible.

That  $\mathfrak{A}$  is conflict-free and self-supporting directly follows from Lemmas A.10 and A.14. Pick any element  $x \in (\Gamma \cup E \cup \Delta)$ .

Then, to prove that  $x \in Acc(\mathfrak{A})$ , condition (ii) remains to be shown. Pick any attack  $\beta \in \mathbf{K}$  with  $\mathbf{t}(\beta) = x$ .

As  $\mathfrak{A}$  is conflict-free, either  $\beta \notin \Gamma$  or  $\mathbf{s}(\beta) \not\subseteq E$ . Hence, since  $\mathfrak{A}$  is stable, it follows that  $\beta \in UnAcc(\mathfrak{A})$  or  $\mathbf{s}(\beta) \cap UnAcc(\mathfrak{A}) \neq \emptyset$  hold. In both cases, it follows that  $\beta \in UnAct(\mathfrak{A})$  and, thus, that  $x \in Acc(\mathfrak{A})$  and that  $\mathfrak{A}$  is admissible.

Now assume  $\mathfrak{A}' = \langle E', \Gamma', \Delta' \rangle$  to be some admissible structure such that  $\mathfrak{A} \sqsubseteq \mathfrak{A}'$ . From Lemma A.13, this implies  $\mathfrak{A} = \mathfrak{A}'$ . That is,  $\mathfrak{A}$  is a  $\sqsubseteq$ -maximal admissible structure and, consequently,  $\mathfrak{A}$  is a preferred one. □

## A.2 Proof of section 6

We address the proof of Theorem 4 in two steps: First, we define an alternative characterisation of the semantics for EBAFs and show that it coincides with the original one in the case of finite EBAFs. Second, we proof that this alternative characterisation coincides with our semantics for non-recursive frameworks even in the case of non-finite EBAFs.

**Definition 16** (Acceptability). *An argument  $a \in \mathbf{A}$  is said to be acceptable w.r.t. a set  $E \subseteq \mathbf{A}$  iff the following two conditions are satisfied:*

1.  $a$  is  $e$ -supported by  $E$ , and
2. for every  $e$ -attack  $(B, a)$ , it holds that  $E$   $e$ -attacks some  $b \in B$ .  $\square$

**Proposition 2.** For finite EBA frameworks, Definitions 16 and 7 are equivalent.  $\square$

*Proof.* It is clear that Definition 16 implies Definition 7 because every minimal  $e$ -attack is also an  $e$ -attack. Furthermore, for every  $e$ -attack  $(B, a)$  w.r.t. some finite EBAF, it is clear that  $B \subseteq \mathbf{A}$  must be finite. Hence, there must be a minimal set  $B' \subseteq B$  such that  $(B', a)$  is a minimal  $e$ -attack. Furthermore,  $E$   $e$ -attacks some  $b \in B' \subseteq B$  implies that  $E$  also  $e$ -attacks some  $b \in B$ .  $\square$

**Definition 17** (Semantics). A set of arguments  $E \subseteq \mathbf{A}$  is said to be

- 1-2. as in Definition 8,
- 3-5. as in Definition 8, but using Definition 16 instead of Definition 7,
6.  $E$  is stable iff  $E$  is self-supporting, conflict-free and any argument  $a \notin E$  which is  $e$ -supported by  $E$  satisfies that either  $a$  or every  $e$ -support  $B$  of  $a$ .

**Proposition 3.** For finite EBA frameworks, Definitions 17 and 8 are equivalent.  $\square$

*Proof.* Conflict-free and self-supporting correspondences follow directly by definition. Admissible, complete and preferred ones follow from Proposition 2. For the stable semantics, from Definition 8 we have

6. *stable* iff it is self-supporting, conflict-free and any argument  $a \notin E$  which is  $e$ -supported by  $\mathbf{A}$  satisfies that  $E$   $e$ -attacks either  $a$  or every minimal  $e$ -support  $B$  of  $a$ .

and, since we are in the finite case, we can drop the minimality criterion.

*stable* iff it is self-supporting, conflict-free and any argument  $a \notin E$  which is  $e$ -supported by  $\mathbf{A}$  satisfies that  $E$   $e$ -attacks either  $a$  or every  $e$ -support  $B$  of  $a$ .

$\square$

**Lemma A.15.** Let EBAF be some framework,  $E \subseteq \mathbf{A}$  be some set and  $a \in \mathbf{A}$  be some argument. Then  $a$  is  $e$ -supported by  $E$  iff  $a$  is  $e$ -supported by  $E \setminus \{a\}$ .  $\square$

*Proof.* First, if  $a = \eta$ , then  $a$  is  $e$ -supported by any set and, in particular, by  $E$  and  $E \setminus \{a\}$ . Hence, we assume without loss of generality that  $a \neq \eta$  and, thus, that there is a non-empty  $C \subseteq E$  such that  $(c, a) \in \mathbf{R}_e$  and every  $c \in C$  is  $e$ -supported by  $E \setminus \{a\}$ . Clearly, if every  $a \in C$ , then  $a$  is  $e$ -supported by  $E \setminus \{a\}$ . Otherwise,  $a \notin C$  implies that  $C \subseteq E \setminus \{a\}$  and, it clear that if every  $c \in C$  is  $e$ -supported by  $E \setminus \{a\}$  then, it is also  $e$ -supported by  $(E \setminus \{a\}) \cup \{a\} = E$ . Hence,  $a$  is  $e$ -supported by  $E \setminus \{a\}$ . The other way around is trivial.  $\square$

**Proposition 4.** *Let  $\mathbf{EBAF}$  be some EBA framework and  $E \subseteq \mathbf{A}$  be some set of arguments. Then, the following assertions hold:*

1.  *$E$  is conflict-free w.r.t.  $\mathbf{EBAF}$  iff  $\mathfrak{A}_E$  is conflict-free w.r.t.  $\mathbf{AF}_{\mathbf{EBAF}}$ ,*
2.  *$a \in \mathbf{A}$  is e-supported by  $E$  w.r.t.  $\mathbf{EBAF}$  iff  $a \in \text{Sup}(\mathfrak{A}_E)$  w.r.t.  $\mathbf{AF}_{\mathbf{EBAF}}$ ,*
3. *if  $E$  is self-supporting and  $a \in \text{Def}_{\mathbf{A}}(\mathfrak{A}_E)$  w.r.t.  $\mathbf{AF}_{\mathbf{EBAF}}$ , then  $E$  e-attacks  $a$  w.r.t.  $\mathbf{EBAF}$ .  $\square$*

*Proof.* First, note that 1 follows directly from the observation  $\mathbf{R}_{\mathfrak{A}} = \mathbf{R}_a$  and that 3 follows directly from 2. Condition 2 can be proved by induction as follows:

First note that, if  $E = \emptyset$ , then  $a$  is e-supported by  $E$  iff  $a = \eta$  iff  $a \in \mathbf{P}$  iff  $a \in \text{Sup}(\mathfrak{A}_E)$  (note that there is no support  $\beta \in \mathbf{S}$  with  $\mathbf{s}(\beta) = \emptyset$ ). Hence, we assume as induction hypothesis that the lemma statement holds for every set  $B \subset E$ . We also assume without loss of generality that  $a \neq \eta$  and, thus,  $a \notin \mathbf{P}$ .

Assume first that  $a$  is e-supported by  $E$ . Then, there is some  $C \subset E$  such that  $(C, a) \in \mathbf{R}_e$  and every  $c \in C$  is e-supported by  $E \setminus \{a\}$ . Pick any  $c \in C$ . Since every  $c \in C$  is e-supported by  $E \setminus \{a\}$ , from Lemma A.15, it follows that every  $c \in C$  is e-supported by  $E \setminus \{a, c\} \subseteq E$ . From induction hypothesis and Lemma A.1, this implies that every  $C \subseteq \text{Sup}(\mathfrak{A}_E \setminus \{a, c\}) \subseteq \text{Sup}(\mathfrak{A}_E \setminus \{a\})$  which, since  $C \subseteq E$ , implies that  $a \in \text{Sup}(\mathfrak{A}_E)$  holds.

Assume now that  $a \in \text{Sup}(\mathfrak{A}_E)$ . Then, there is some support  $\beta \in \mathbf{S}$  such that  $\mathbf{s}(\beta) \subseteq (E \cap \text{Sup}(\mathfrak{A}_E \setminus \{a\}))$  and  $\mathbf{t}(\beta) = a$ . If  $\mathbf{s}(\beta) = \{\eta\}$ , then  $\eta$  is e. Pick any  $c \in \mathbf{s}(\beta)$ . Since  $c \in \text{Sup}(\mathfrak{A}_E)$ , from Lemma A.11, it follows that  $c \in \text{Sup}(\mathfrak{A}_E \setminus \{c\})$ . Furthermore,  $c \in E$  implies  $E \setminus \{c\} \subset E$  and, by induction hypothesis, we get that  $c$  is e-supported by  $E \setminus \{c\}$ . Hence, every  $c \in \mathbf{s}(\beta)$  is e-supported by  $E \setminus \{c\}$ , which, together with  $\mathbf{s}(\beta) \subseteq E$ , implies that  $a$  is e-supported by  $E$ .  $\square$

**Lemma A.16.** *Let  $E, B \subseteq \mathbf{A}$  be two sets of arguments such that  $B$  is self-supporting w.r.t. some  $\mathbf{EBAF}$ . Then,  $B \cap \overline{\text{Sup}(\mathfrak{A}' )} \neq \emptyset$  with  $\mathfrak{A}' = \langle \text{Def}_{\mathbf{A}}(\mathfrak{A}_E), \mathbf{K}, \mathbf{S} \rangle$  implies  $B \cap \text{Def}_{\mathbf{A}}(\mathfrak{A}_E) \neq \emptyset$ .*

*Proof.* Pick any  $b \in B \cap \overline{\text{Sup}(\mathfrak{A}' )}$ . Since  $B$  is a self-supporting set, it follows that  $b$  is e-supported by  $B$  and, from Proposition 4, that  $b \in \text{Sup}(\mathfrak{A}_B)$ . Suppose, for the sake of contradiction, that  $B \cap \text{Def}_{\mathbf{A}}(\mathfrak{A}_E) = \emptyset$ . Then,  $B \subseteq \overline{\text{Def}_{\mathbf{A}}(\mathfrak{A}_E)}$  which implies that  $\mathfrak{A}_B \sqsubseteq \mathfrak{A}'$ . From Lemma A.1, this implies that  $b \in \text{Sup}(\mathfrak{A}_B) \subseteq \text{Sup}(\mathfrak{A}' )$  which is a contradiction with the assumption. Consequently,  $B \cap \text{Def}_{\mathbf{A}}(\mathfrak{A}_E) \neq \emptyset$ .  $\square$

**Proposition 5.** *Let  $\mathbf{EBAF}$  be some EBA framework and  $E \subseteq \mathbf{A}$  be a conflict-free, self-supporting set w.r.t.  $\mathbf{EBAF}$ . An argument  $a \in \mathbf{A}$  is a acceptable w.r.t.  $\mathfrak{A}_E$  iff  $a$  is acceptable w.r.t.  $E$  (Definition 16).  $\square$*

*Proof.* First note that, by definition,  $a \in \mathbf{A}$  being a acceptable w.r.t.  $\mathbf{AF}_{\mathbf{EBAF}}$  implies  $a \in \text{Sup}(\mathfrak{A})$  which, from Proposition 4, implies that  $a$  is e-supported by  $E$ .

Hence, it just remains to be shown that, for every minimal e-attack  $(B, a)$ , it holds that  $E$  e-attacks some  $b \in B$ . Since  $B$  e-attacks  $a$ , there is some  $(C, a) \in \mathbf{R}_a$  with  $C \subseteq B$ . Let  $\alpha \in \mathbf{K}$  be the attack name such that  $\mathbf{s}(\alpha) = C$  and  $\mathbf{t}(\alpha) = a$ . Since  $a$  is acceptable w.r.t.  $\mathfrak{A}_E$  and  $\mathbf{AF}_{\mathbf{EBAF}}$ , it follows that either  $\alpha \in \text{UnAcc}(\mathfrak{A}_E)$  or  $\mathbf{s}(\alpha) \cap \text{UnAcc}(\mathfrak{A}) \neq \emptyset$ . Furthermore, since there is no attack targeting  $\alpha$  and  $\alpha \in \mathbf{K} \subseteq \mathbf{P}$ , it immediately follows that  $\alpha \notin \text{UnAcc}(\mathfrak{A}_E)$ . Hence, we assume without loss of generality that  $\mathbf{s}(\alpha) \cap \text{UnAcc}(\mathfrak{A}_E) \neq \emptyset$ .

This implies the existence of some argument  $c \in \mathbf{s}(\alpha)$  s.t. either  $c \in \text{Def}_{\mathbf{A}}(\mathfrak{A}_E)$  or  $c \notin \text{Sup}(\mathfrak{A}')$  with  $\mathfrak{A}' = \langle \overline{\text{Def}_{\mathbf{A}}(\mathfrak{A}_E)}, \mathbf{K}, \mathbf{S} \rangle$ . Furthermore, the latter implies that there is some  $c' \in \mathbf{s}(\alpha) \cap \text{Def}_{\mathbf{A}}(\mathfrak{A}_E)$  (see Lemma A.16). Hence, in both cases, there is some  $b \in \mathbf{s}(\alpha) \cap \text{Def}_{\mathbf{A}}(\mathfrak{A}_E)$ . Since  $b \in \mathbf{s}(\alpha) \subseteq C \subseteq B$ , from Proposition 4, it follows that  $E$  e-attacks  $b$  and, thus, that  $a$  is acceptable w.r.t.  $E$ .

For the if direction, we will show that  $\mathbf{s}(\alpha) \cap \text{UnAcc}(\mathfrak{A}) \neq \emptyset$  for any attack  $\alpha \in \mathbf{K}$  with  $\mathbf{t}(\alpha) = a$ . First note that, from Definition 14, we have that  $(C, a) \in \mathbf{R}_a$  with  $C = \mathbf{s}(\alpha)$ . Suppose, for the sake of contradiction, that  $\mathbf{s}(\alpha) \cap \text{UnAcc}(\mathfrak{A}) = \emptyset$  and, thus,  $C \cap \text{UnAcc}(\mathfrak{A}) = \emptyset$  hold. This implies that  $B = C \cup \overline{\text{Def}_{\mathbf{A}}(\mathfrak{A}_E)}$  is a self-supporting set<sup>11</sup> and, thus,  $(B, a)$  is an e-attack. Then, since  $a$  is acceptable w.r.t.  $E$ , this implies that  $E$  e-attacks some  $b \in B = C \cup \overline{\text{Def}_{\mathbf{A}}(\mathfrak{A}_E)}$ . Note that  $E$  e-attacks  $b$  implies that  $b \in \text{Def}_{\mathbf{A}}(\mathfrak{A}_E) \subseteq \text{UnAcc}(\mathfrak{A}_E)$  and, thus, that  $b \in C$  and that  $C \cap \text{UnAcc}(\mathfrak{A}_E) \neq \emptyset$ . This implies that  $a$  is acceptable w.r.t.  $\mathfrak{A}_E$ .  $\square$

**Proposition 6.** *A set of arguments  $E \subseteq \mathbf{A}$  is admissible (resp. complete or preferred) w.r.t. some finite  $\mathbf{EBAF}$  iff  $\mathfrak{A}_E$  is an admissible (resp. complete or preferred) d-structure w.r.t.  $\mathbf{AF}_{\mathbf{EBAF}}$ .*  $\square$

*Proof.* Directly from Propositions 4 and 5.  $\square$

**Lemma A.17.** *Let  $E \subseteq \mathbf{A}$  be a stable set. Then, every  $B \subseteq \mathbf{A}$  satisfies: for each  $a \in \mathbf{A}$ ,  $a \notin \text{Sup}(\mathfrak{A}_E)$  and  $B$  e-supports  $a$  imply that  $E$  e-attacks some  $b \in B$ .*

*Proof.* In case that  $B = \emptyset$ , it follows that  $B$  e-supports  $a$  implies that  $a = \eta \in \mathbf{P}$  and, thus,  $a \in \text{Sup}(\mathfrak{A}_E)$  so the lemma statement holds vacuous. Then, we proceed by induction assuming that the lemma statement holds for every strict subset  $B' \subset B$ . Note that  $a \notin \text{Sup}(\mathfrak{A}_E)$  implies that  $a \neq \eta$ , as  $\eta \in \mathbf{P}$ . Furthermore,  $B$  e-supports  $a$  implies that there is a support  $\alpha \in \mathbf{S}$  with  $\mathbf{t}(\alpha) = a$  such that every  $c \in \mathbf{s}(\alpha) \subseteq B$  is e-supported by  $B \setminus \{a\}$ . From Lemma A.15, this implies that  $c$  is e-supported by  $B \setminus \{a, c\} \subset B$ . Moreover,  $\mathbf{s}(\alpha) \subseteq E \cap \text{Sup}(\mathfrak{A}_E \setminus \{a, c\})$  would imply  $\mathbf{s}(\alpha) \subseteq E \cap \text{Sup}(\mathfrak{A}_E \setminus \{a, c\})$  (Lemma A.1) and, thus,  $a \in \text{Sup}(\mathfrak{A}_E)$  which is a contradiction, so there is some  $c \in \mathbf{s}(\alpha) \setminus \text{Sup}(\mathfrak{A}_E \setminus \{a, c\})$  or some  $c \in \mathbf{s}(\alpha) \setminus E$ . By induction hypothesis, the former implies that  $E$  e-attacks some  $c \in B \setminus \{a, c\}$  and, thus, that it e-attacks some  $c \in B$ .

Hence, we assume without loss of generality that  $c \notin E$ . Note that, since  $c$  is e-supported by  $B \setminus \{a\} \subseteq \mathbf{A}$ , it is also e-supported by  $\mathbf{A}$ . Since  $E$  is stable,

<sup>11</sup>Note that  $C \cap \text{UnAcc}(\mathfrak{A}) = \emptyset$  implies that  $C \subseteq \text{Sup}(\mathfrak{A}')$  with  $\mathfrak{A}' = \langle \overline{\text{Def}_{\mathbf{A}}(\mathfrak{A})}, \mathbf{K}, \mathbf{S} \rangle$ . From Proposition 4, this implies that  $C$  is e-supported by  $\text{Def}_{\mathbf{A}}(\mathfrak{A}_E)$ .

this implies that  $E$  e-attacks either  $c$  or some  $c' \in B'$  for every e-support  $B'$  of  $c$ . In both cases  $E$  e-attacks some  $b \in B$ .  $\square$

**Proposition 7.** *A set of arguments  $E \subseteq \mathbf{A}$  is stable w.r.t. some **EBAF** (Definition 17) iff  $\mathfrak{A}_E$  is stable w.r.t. **AF<sub>EBAF</sub>**.  $\square$*

*Proof.* For the if direction, we have that  $\mathfrak{A}_E$  is self-supporting and conflict-free (Theorem 2) and, from Proposition 4, this implies that  $E$  is a self-supporting and conflict-free set. Hence, we have to show that any argument  $a \notin E$  which is e-supported by  $\mathbf{A}$  satisfies that  $E$  e-attacks either  $a$  or every e-support  $B$  of  $a$ . Note that, from Definition 12,  $a \notin E$  implies that  $a \in \overline{UnAcc(\mathfrak{A}_E)}$ . Besides, since there is no attack against supports or other attacks, it follows that  $Def_X(\mathfrak{A}_E) = \emptyset$  with  $X \in \{\mathbf{K}, \mathbf{S}\}$ .

Then,  $a \in \overline{UnAcc(\mathfrak{A}_E)}$  implies that either  $a \in Def(\mathfrak{A}_E)$  or  $a \notin Sup(\mathfrak{A}')$  holds with  $\mathfrak{A}' = \langle \overline{Def_{\mathbf{A}}(\mathfrak{A}_E)}, \mathbf{K}, \mathbf{S} \rangle$ . Note that, since  $E$  is self-supporting,  $a \in Def(\mathfrak{A}_E)$  implies that  $E$  e-attacks  $a$  (Proposition 4). Moreover, since  $\mathfrak{A}_E$  is conflict-free, it follows that  $\mathfrak{A}_E \sqsubseteq \mathfrak{A}'$  and, thus, also that  $Sup(\mathfrak{A}_E) \subseteq Sup(\mathfrak{A}')$  (Lemma A.1). From this, it follows that  $a \notin Sup(\mathfrak{A}')$  implies  $a \notin Sup(\mathfrak{A}_E)$ . From Lemma A.17, this implies that  $E$  e-attacks every e-support  $B$  of  $a$ . Consequently,  $E$  is a stable set.

For the only if direction, from Definition 14, we have

$$X = \mathbf{P} \cap X = Sup_X(\mathfrak{A}_E) = Sup_X(\mathfrak{A}')$$

with  $X \in \{\mathbf{K}, \mathbf{S}\}$ . Since there is no attack against supports or other attacks,  $Def_X(\mathfrak{A}_E) = \emptyset$  with  $X \in \{\mathbf{K}, \mathbf{S}\}$ . Therefore, it follows that  $X = \overline{UnAcc(\mathfrak{A}_E)} \cap X$  with  $X \in \{\mathbf{K}, \mathbf{S}\}$ . Hence, it is enough to show that  $E = \overline{UnAcc(\mathfrak{A}_E)} \cap \mathbf{A}$ .

Note that  $\overline{UnAcc(\mathfrak{A}_E)} = Sup_{\mathbf{A}}(\mathfrak{A}') \setminus Def_{\mathbf{A}}(\mathfrak{A}_E)$  with  $\mathfrak{A}' = \langle \overline{Def_{\mathbf{A}}(\mathfrak{A}_E)}, \mathbf{K}, \mathbf{S} \rangle$ , so we have to prove

$$E = Sup_{\mathbf{A}}(\mathfrak{A}') \setminus Def_{\mathbf{A}}(\mathfrak{A}_E)$$

Since  $E$  is a self-supporting set, it follows that every  $a \in E$  is e-supported by  $E$  and, from Proposition 4, that  $a \in Sup(\mathfrak{A}_E)$ . Furthermore, since  $E$  is conflict-free, from Proposition 4, this implies that  $\mathfrak{A}_E$  is also conflict-free and, thus, we have that  $\mathfrak{A}_E \sqsubseteq \mathfrak{A}'$ . From Lemma A.1, this implies  $E \subseteq Sup_{\mathbf{A}}(\mathfrak{A}_E) \subseteq Sup_{\mathbf{A}}(\mathfrak{A}')$ . Moreover, the fact that  $\mathfrak{A}_E$  is conflict-free also implies that  $E \cap Def_{\mathbf{A}}(\mathfrak{A}_E) = \emptyset$  and, thus, that  $E \subseteq Sup_{\mathbf{A}}(\mathfrak{A}') \setminus Def_{\mathbf{A}}(\mathfrak{A}_E)$ .

The other way around. Pick  $a \in Sup_{\mathbf{A}}(\mathfrak{A}') \setminus Def_{\mathbf{A}}(\mathfrak{A}_E)$ . Hence, there is a support  $\alpha \in \mathbf{S}$  with  $\mathbf{t}(\alpha) = a$  and  $\mathbf{s}(\alpha) \subseteq \overline{Def_{\mathbf{A}}(\mathfrak{A}_E)} \cap Sup_{\mathbf{A}}(\mathfrak{A}' \setminus \{a\})$ .

Then, from Proposition 4 and the fact that  $\mathbf{s}(\alpha) \subseteq Sup_{\mathbf{A}}(\mathfrak{A}' \setminus \{a\})$ , it follows that every  $b \in \mathbf{s}(\alpha)$  is e-supported by  $\overline{Def_{\mathbf{A}}(\mathfrak{A}_E)} \setminus \{a\}$ . Furthermore, since  $\mathbf{s}(\alpha) \subseteq \overline{Def_{\mathbf{A}}(\mathfrak{A}_E)}$ , it follows that  $Def_{\mathbf{A}}(\mathfrak{A}_E)$  e-supports  $a$ . Furthermore,  $a \notin Def_{\mathbf{A}}(\mathfrak{A}_E)$  implies that  $E$  does not e-attacks  $a$ .

Then, since  $E$  is stable, either  $a \in E$  or  $E$  e-attacks some  $b \in \overline{Def_{\mathbf{A}}(\mathfrak{A}_E)}$ . Note that  $E$  e-attacks  $b$  implies that  $b \in Def_{\mathbf{A}}(\mathfrak{A}_E)$  which is a contradiction. So  $a \in E$  must hold. This implies  $E \supseteq Sup_{\mathbf{A}}(\mathfrak{A}') \setminus Def_{\mathbf{A}}(\mathfrak{A}_E)$  and, thus,  $E = Sup_{\mathbf{A}}(\mathfrak{A}') \setminus Def_{\mathbf{A}}(\mathfrak{A}_E)$ . Consequently,  $\mathfrak{A}_E$  is stable.  $\square$



**Theorem 5.** *Let  $\mathbf{EBAF}$  be some (possibly infinite) EBA framework. Then, the function  $\mathbf{struct}_{\mathbf{EBAF}}(\cdot)$  is a one-to-one correspondence between its self-supporting (resp. conflict-free, admissible, complete, preferred or stable) sets according to Definition 17 and the self-supporting (resp. conflict-free, admissible, complete, preferred or stable) d-structures of its corresponding framework  $\mathbf{AF}_{\mathbf{EBAF}}$ .  $\square$*

*Proof.* First, note that from Propositions 6 and 7, it directly follows that a set  $E \subseteq \mathbf{A}$  is self-supporting (resp. conflict-free, admissible, complete, preferred or stable) iff  $\mathbf{struct}_{\mathbf{EBAF}}(E) = \mathfrak{A}_E$  is a self-supporting (resp. conflict-free, admissible, complete, preferred or stable) d-structure w.r.t.  $\mathbf{AF}_{\mathbf{EBAF}}$ . Furthermore, by construction of  $\mathfrak{A}_E = \langle E, \mathbf{K}, \mathbf{S} \rangle$  it is clear  $\mathbf{struct}_{\mathbf{EBAF}}(\cdot)$  is injective. To see that it is also surjective just note that, from Observation 2, every d-structure is of the form  $\mathfrak{A}_E$  for some set of arguments  $E \subseteq \mathbf{A}$ .  $\square$

**Theorem 4.** *Let  $\mathbf{EBAF}$  be some finite EBA framework. Then, the function  $\mathbf{struct}_{\mathbf{EBAF}}(\cdot)$  is a one-to-one correspondence between its self-supporting (resp. conflict-free, admissible, complete, preferred or stable) sets according to Definition 8 and the self-supporting (resp. conflict-free, admissible, complete, preferred or stable) d-structures of its corresponding framework  $\mathbf{AF}_{\mathbf{EBAF}}$ .  $\square$*

*Proof.* Follows directly from Proposition 3 and Theorem 5.  $\square$