



**HAL**  
open science

## Formulation of optimized excavatable cement treated materials using a new punching test apparatus

Eric Gennesseaux, Thierry Sedran, Jean Michel Torrenti, Michel Hardy

### ► To cite this version:

Eric Gennesseaux, Thierry Sedran, Jean Michel Torrenti, Michel Hardy. Formulation of optimized excavatable cement treated materials using a new punching test apparatus. *Materials and structures*, 2018, 51, 13 p. 10.1617/s11527-018-1184-1 . hal-02875108v1

**HAL Id: hal-02875108**

**<https://hal.science/hal-02875108v1>**

Submitted on 19 Jun 2020 (v1), last revised 25 Jan 2024 (v2)

**HAL** is a multi-disciplinary open access archive for the deposit and dissemination of scientific research documents, whether they are published or not. The documents may come from teaching and research institutions in France or abroad, or from public or private research centers.

L'archive ouverte pluridisciplinaire **HAL**, est destinée au dépôt et à la diffusion de documents scientifiques de niveau recherche, publiés ou non, émanant des établissements d'enseignement et de recherche français ou étrangers, des laboratoires publics ou privés.

# MIX DESIGN OF OPTIMIZED EXCAVATABLE CEMENT TREATED MATERIALS USING A NEW PUNCHING TEST APARATUS

E. Genesseaux,  
IFSTTAR, MAST, MIT, F-44340 Bouguenais, France  
[Eric.genesseaux@ifsttar.fr](mailto:Eric.genesseaux@ifsttar.fr)

T. Sedran  
IFSTTAR, MAST, MIT, F-44340 Bouguenais, France

J.M. Torrenti,  
Université Paris-Est, MAST, IFSTTAR, F-77420 Marne-La –Vallée, France

M. Hardy  
EngieLab CRIGEN, Centre de Recherches Gaz et Energies Nouvelles, ENGIE, 93210 Saint Denis,  
France

## ABSTRACT

Classical techniques for backfilling of trenches use unbounded materials. Unfortunately, they have always been presenting several drawbacks: difficulty of compaction, noise disturbance and time of implementation... Controlled Low Strength Materials (CLSM) could be a good alternative thanks to their fluidity and cementitious setting, provided that they remain excavatable, even with a pick. In fact, it is essential to ensure a rapid and easy permanent access to the underlying networks, in case of emergency or maintenance. Modular concrete pavements were developed during the last years for that purpose. The concrete elements are laid on a base of cement treated material to keep their stability. They are designed to be easily removed but the base material must be excavated with a light facility as well. Yet, until recently, the excavatability was not well defined, nor well measured.

Recently, a new approach based on a simple laboratory punching test was developed at Ifsttar to provide a quantitative characterization in laboratory of cement treated materials excavatability.

This paper first details the general approach. Then a large parametric experimental campaign conducted with the punching test on mixes with various compositions is presented. From the results obtained, a model linking the mix proportions to the pick penetration depth is proposed. Finally, excavations are realized on real scale trenches to confirm that the optimization of the penetration leads to a better excavatability of the material.

## KEYWORDS

CONTROLLED LOW-STRENGTH MATERIALS / CEMENT BASED MATERIALS / / EXCAVATABILITY / PICK / PUNCHING TEST / TRENCH/ URBAN PAVEMENTS.

## 1. INTRODUCTION

For network owners, the use of Controlled Low Strength Materials (CLSM) has always been an interesting solution for backfilling of trenches since it presents several advantages (Bonnet, et al., 1998). Indeed, those materials provide an easy implementation thanks to their fluidity and to a self-compacting capacity which can be given to them, avoiding heavy compacting equipment, reducing the implementation time and further settlements (ACI-229R-99, 1999). The bearing capacity is then obtained thanks to the hydration of the binder. This kind of material can be obtained thanks to low cement content and whatever the base layer is made of, self-compacting materials with low cement content could be used more widely for back-filling of urban trenches permitting narrower trenches. CLSM have become popular for projects such as, foundation support, pavement base and conduit bedding but the dissemination of this solution is hampered by the need to ensure their excavatability. As a matter of fact, it is essential to ensure a rapid access to the networks, even with a simple pick at the vicinity of a network, for normal or emergency maintenance matters. Yet

this aspect has not been well managed up to now, because excavatability was not well defined, nor well measured. As a consequence, the relationship between mix design of cementitious materials and excavatability was not clearly established.

The classical excavatability evaluation methods of those cementitious materials are based on excavated volumes quantification (Pons, et al., 1998) or on subjective difficulty rating obtained after heavy in-situ real scale excavations (Crouch, et al., 2003; NCHRP, 2008). Those methods appeared to be unsatisfying because they are difficult to perform (heavy equipment), they only permit a characterization after the implementation of the material in the trench (and not in laboratory) and they do not take into account the excavation energy. Consequently, a new method was developed at IFSTTAR based on a laboratory punching test which predicts, in laboratory, the pick's tool penetration to be obtained in-situ. It was proven to be efficient for excavatability evaluation of cementitious materials (Morin, 2009; Morin, et al., 2013; Morin, et al., 2017), (Genesseaux, 2015) since the penetration depth of the tool is strongly linked to the difficulty of excavation for a specific impact energy.

This approach, detailed below, is used for the present study to research some influencing parameters of the mix design on penetration and thus excavatability in order to optimize it.

The unconfined compressive strength is considered as the only criterion of excavatability in France (CERTU, 1998) and in the USA (ACI-229R-99, 1999) where a specific strength value (2 MPa for CERTU and 1.4 MPa for ACI) is defined as a limit between excavatable and non-excavatable materials using a backhoe. However, this criterion differs from a country to another and does not depend on the excavation tool power, making it unreliable. Moreover, those yield values appeared to be insufficient in some cases (Crouch, et al., 2003; NCHRP, 2008; Morin, 2009), and too restrictive in others (Webb, et al., 1998). In conclusion, even if compressive strength is undoubtedly a major parameter, secondary parameters have probably to be accounted for.

Fortunately, the literature review led to identify some potential parameters to focus on. The increase of air content was identified to facilitate excavation aside its direct influence on compressive strength (Crouch, et al., 2003). On the same subject, an excavatability criterion named Removability modulus (RE) is described in several papers (Hamcin, 1996) whose calculation depends on the specific density of the material and consequently on the air content.

In (Krell, 1989; Crouch, et al., 1998; Halmen, 2005) the authors suggest that the volume of paste influences the excavatability. It seems relevant as the paste is the weak part in CLSM compared to the granular skeleton. Finally, the maximum aggregate diameter was proved to play a role on excavatability as it controls interlocking when material is pulled off (Morin, 2009), as it will be described in the next paragraph. Those potential parameters of influence are studied in this research.

In that context, the present paper first describes the new approach selected here for the characterization in laboratory of the excavatability with a pick. A second part details a large parametric experimental campaign conducted with the punching test on mixes with various compositions. To conclude, a model linking the mix proportions to the pick penetration depth and then the excavated volume is proposed.

## **2. A NEW APPROACH TO CHARACTERIZE THE EXCAVATABILITY**

In order to characterize the excavatability of a CLSM, Morin proposed a new approach based on a laboratory punching test apparatus (Figure 3), (Morin, 2009; Morin, et al., 2013; Morin, et al., 2017). This method was then validated on a large experimental campaign comparing in-situ manual excavation operated by an experimented worker, to laboratory punching tests mixes (Genesseaux, 2015).

The approach considers the excavated volume as a criterion to differentiate the levels excavation difficulties. Indeed, a good correlation was found between the excavated volume and the difficulty rating given by a manual operator; enabling the determination of excavatability thresholds on the excavated volume (Figure 1).

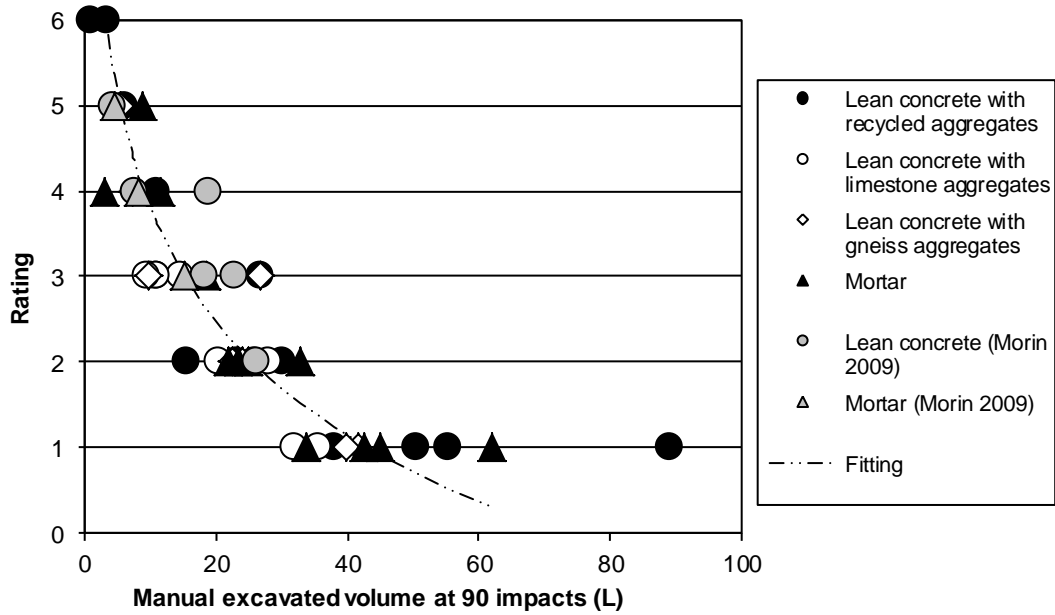

Figure 1 - Comparison between the note and the excavated volume (Gennesseaux, 2015)

A simple prismatic rupture model (Figure 2) was proposed to predict the excavated volume for 90 impacts (this value was arbitrarily selected to mean the experimental measurements with a reasonable effort) with a mean error of 5.6 L (for volumes of about 30 to 45 L for an easy excavation level) using the following equations:

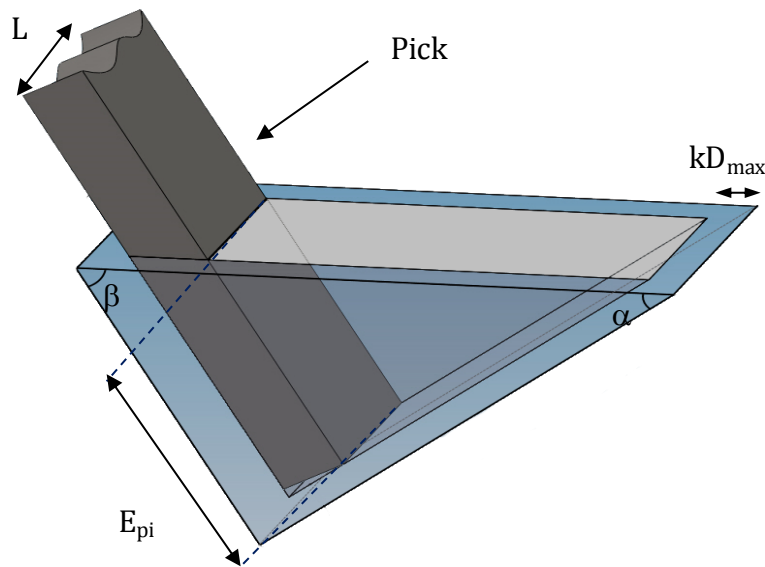

Figure 2 - Rupture mechanism of backfilled materials. A surrounding supplementary volume is accounted for due to aggregate interlocking)

$$V_{\text{theoretical}} = \frac{90}{2} a'^2 \left( \frac{1}{\tan(\beta)} + \frac{1}{\tan\left(\frac{\pi}{2} - \frac{(\beta + \varphi)}{2}\right)} \right) (L + 2k.D_{90}) \quad (1)$$

$$\text{With } a' = E_{pi} \times \sin(\beta) + k.D_{90} [\sin(\beta) + \cos(\beta)] \quad (2)$$

$\varphi$  is the internal friction angle,  $L$  the width of the blade and  $\beta$  the angle of penetration of the blade. The parameter  $k$  describes the fact that during the de-compaction of the material, a supplementary peripheral volume is entrained due to interlocking of aggregates which thickness is  $k.D_{90}$ ;  $D_{90}$  being the diameter through which 90% of the grading curve is passing.

Finally,  $E_{pi}$  is the penetration depth of the pick's blade into the material. It was shown in (Genesseaux, 2015) that a correlation exists between  $E_{pi}$  and the measurement of the penetration of the laboratory punching tests  $E_{pc}$  considering the same penetration/impact energy though the following equation:

$$E_{pc} = 0.72 \times E_{pi} \quad (3)$$

Using this set of equations, excavated volume thresholds were converted in an abacus of excavatability (see Figure 2). Knowing the excavatability rating to aim at, and the  $D_{90}$  of the mixture, this abacus gives the mix designer the minimum punching test penetration  $E_{pc}$  to reach in laboratory in order to certify this rating in-situ.

A detailed presentation of the method can be found in (Genesseaux, 2015).

The laboratory punching test consists of a 18 mm diameter flat-bottomed circular punch, designed to match the area of the flat head of a pick and used to load normally the surface of a material sample at a constant speed of 900 mm/min. A stiff displacement-controlled 150kN compressive testing machine was used to produce all the data collected for this paper.



Figure 3 – Punching test device

Cylindrical specimens confined in a metallic mold of 16 cm in height and 16 cm in diameter are used as samples (Figure 3). The thickness of the mold was chosen to disable peripheral strains in order to reproduce the confinement of the material in the trench (Morin, et al., 2017).

During the test, the displacement is monitored by a potentiometer sensor whose maximum range is 100 mm. The stress is monitored by a load sensor with a 100 kN capacity. The output voltages from the devices are recorded using a computer with an HBM Spider8 acquisition box at a 10 Hz frequency to get a real time plot of the force-penetration curve. The test is repeated on six samples for a given mix at a given age to account for experimental scattering and a mean curve is plotted.

This curve is then integrated to plot a work-penetration curve used to measure the penetration at a given energy of impact/work. The complete procedure is detailed in a technical guide (Ifstar et Engie, 2016) recently edited for the French construction community.

Finally, this punching test apparatus can be used to predict, in laboratory, the pick's tool penetration which would be obtained in-situ for a specific impact energy.

The average impact energy of a traditional operator was estimated at 350 J using a high speed camera to determine the pick speed at the impact but the approach can be generalized for other energy levels (higher than 150 J) using the following relationship (Genesseaux, 2015):

$$E_{pc}(W) = E_{pc}(350) \cdot (0,0021 \cdot W + 0,264) \quad (4)$$

Where  $W$  is the energy level considered (in J).

This generalization should enable further extension of the method for other excavation tools with different levels of energy such as jackhammers.

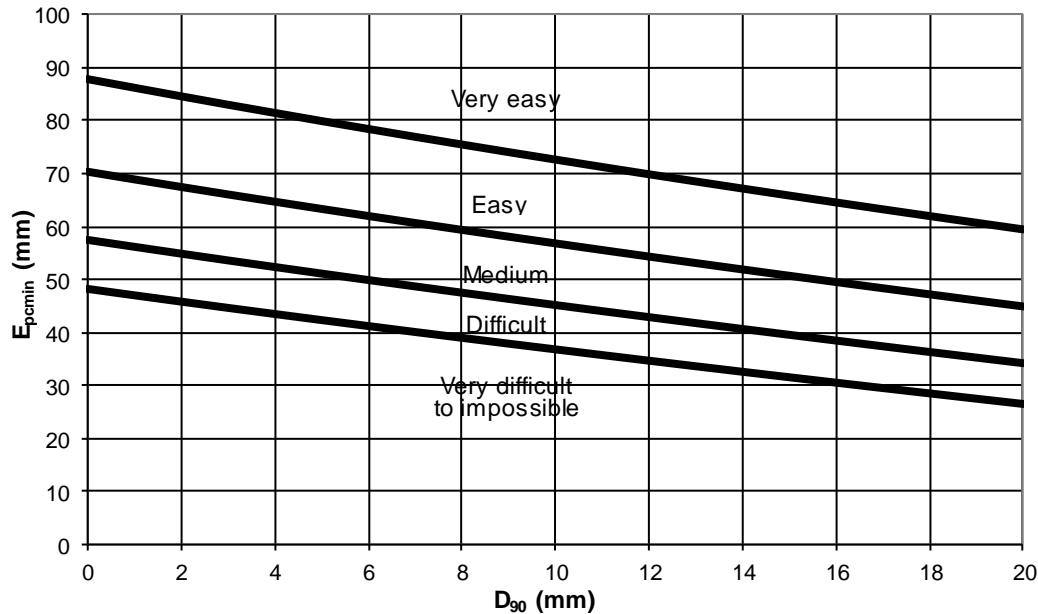

Figure 4 –Excavatability prediction abacus

### 3. EXPERIMENTAL CAMPAIGN

#### 3.1. CHOICE OF COMPONENTS AND MIX DESIGN

Let's consider here that an excavatable CLSM is a material made of two phases:

- The aggregate skeleton : which is the hard phase since its strength is much higher than the unconfined compression strength of CLSM itself (less than 8.3 MPa according to (ACI-229R-99, 1999));
- The cement paste: considered as the weakest phase.

The pick's head, during the penetration, will hit those two phases until being stopped when the impact energy is finally dissipated. Consequently, it seems reasonable to imagine that an increase of the weak phase volume (the paste volume) would make the penetration easier as suggested by the literature review.

In the same way, the air entrainment could be a good way to improve excavatability by increasing the paste content, but also since a porous phase appears weaker than a dense one.

The grading curve is also an intuitive parameter and could be considered through two aspects: the maximum diameter of the aggregates ( $D_{90}$ ) and the shape of the grading curve itself. (Morin, 2009; Morin, et al., 2013) showed that the  $D_{90}$  has a positive influence on the excavated volume due to interlocking after pick impact. But we can also wonder if the size and proportion of coarse aggregates have a direct influence on pick penetration itself as they probably play a role on the probability to intercept the pick course and then dissipate more energy as hard particles of the material. For this study, we will consider the coarse aggregate/sand mass ratio (CA/S) as an indicator of the grading curve, since it is commonly used for concrete.

In this context, the following parameters are studied in the present research, in addition to the compressive strength of the mixes:

- The paste volume (i.e. the aggregate volume);
- The nature (hardness) of the aggregates, through sand friability or Los Angeles value;
- The grading curve of the skeleton through the maximum aggregate diameter  $D_{90}$  and the coarse aggregate to sand mass ratio (CA/S);

- The percentage of entrained air.

The evolution of excavatability with time is not a studied parameter in this paper but it is implicitly taken into account through the unconfined compressive strength value at the same age. Here, all the tests were performed at 28 days.

Table 1 summarizes some characteristics of the materials used for this experimental campaign. An identification number was given to them for sake of clarity.

In addition, the same cement CEM II A/LL 42.5 from Airvault and limestone filler Betocarb HP EB were used for the different mixes. Finally, to study the influence of air content on penetration, a stable air entrained agent Betomouss was selected to generate mortars and lean concretes with air content going from 2% up to 30%.

Table 1 – Characteristics of the aggregates used for the mixes

N°	Material	Nature	Sand friability/Los Angeles value	Density [kg/m <sup>3</sup> ]	Water Absorption [%]
1	Sand 0/4 St-Colomban	Silica-pliocene	21	2620	0.3
2	Sand 0/4 Pilier	Silica-limestone	27	2600	0.9
3	Sand 0/4 St-Maurice-la-Clouère	Crushed limestone	62	2530	2.8
4	Coarse aggregate Raon l'étape 4/6.3 and 6.3/14	Crushed andesite	7	2800	0.4
5	Coarse aggregate Maraichères 6/10. 10/14 and 14/20	Crushed gneiss	20	2630	0.5
6	Coarse aggregate St-Fraignes 6/12	Crushed limestone	40	2380	5.2
7	Coarse aggregate Jaillon 4/10 et 10/20	Crushed limestone	50	2360	5.5

For this experimental campaign, we tried to compare similar families of mixes grouped in clusters and differing by the value of only one parameter. For each family of mixes, the components and the grading curves were first selected. Then the water content was adjusted to ensure a reasonable self-compacting property of the material. Finally, for each family, several mixes were generated with different unconfined compressive strength in order to cover approximatively the interval 0.5 MPa to 2.5 MPa. This interval enables a priori to cover the different excavatability levels from very easy to very difficult. The strength was controlled by replacing volume per volume filler by cement in order to keep the fine volume constant between the mixes of a same family.

Table 2 details the mixes tested for the study of the parameters “paste volume” and “air entrained”. The clusters of mixes were named as follow:

- M or C for mortars or concrete respectively;
- V<sub>p</sub> or Air if the studied parameter is the paste volume or the air-entrained parameter, respectively;
- G1 and G2 are the different fractions of coarse aggregates, from the finest to the coarsest, V<sub>p</sub>=paste volume without air; W=efficient water

The name of the families is a concatenation of the cluster name and XX% referring to the volume of paste or of air aimed for the mixtures, respectively.

The same components and grading curves are used within each cluster.

Table 2 – Proportions and characteristics of the mixes of the clusters “Paste volume” and “Air entrained”. Masses are given for dry aggregates.

Cluster	Family	Sand n°	Gravel n°	C	F	S	G1	G2	AEA	W	Air	Vp	R <sub>c28</sub>	Epc350	D <sub>50</sub>	D <sub>90</sub>	
				[kg]	[kg]	[kg]	[kg]	[kg]	[kg]	[kg]	[kg]	[%]	[%]	[MPa]	[mm]	[mm]	[mm]
M_Vp	M_Vp_40%	2	-	84	250	1480				258	1,0%	40,4%	1,45	22,8	0,5	2,2	
				98	237	1480				258	1,3%	40,6%	2,00	21,4	0,5	2,2	
				59	272	1480				258	1,9%	40,9%	0,55	35,7	0,5	2,2	
	M_Vp_50%	2	-	116	550	1480				296	1,5%	49,2%	2,21	21,3	0,4	1,9	
				99	564	1480				297	1,4%	49,2%	1,07	29,4	0,4	1,9	
				68	591	1480				297	1,6%	49,3%	0,64	36,7	0,4	1,9	
	M_Vp_70%	2	-	135	795	780				353	0,8%	69,6%	2,15	25,6	0,1	1,6	
				117	805	780				353	1,0%	69,9%	1,31	35,1	0,1	1,6	
				80	843	780				353	2,1%	70,3%	0,68	49,5	0,1	1,6	
	M_Vp_100%	-	-	80	1393					460	1,0%	100,0%	0,73	65,7	0,0	0,1	
				130	1349					460	1,0%	100,0%	1,56	43,1	0,0	0,1	
				190	1296					460	1,0%	100,0%	3,50	30,8	0,0	0,1	
C_Vp	C_Vp_30%	2	5	65	77	856	104	920		197	1,8%	26,8%	1,32	26,3	4,5	13,6	
				38	100	856	104	920		197	2,1%	27,1%	0,40	42,7	4,5	13,6	
				73	70	856	104	920		197	2,3%	27,3%	1,52	23,3	4,5	13,6	
				83	62	856	104	920		197	2,9%	27,6%	1,69	20,5	4,5	13,6	
	C_Vp_40%	2	5	66	410	724	88	778		201	0,5%	38,3%	2,07	20,6	1,6	13,3	
				77	400	724	88	778		201	1,4%	38,8%	2,66	16,4	1,6	13,3	
				27	444	724	88	778		201	0,5%	38,3%	0,44	40,7	1,6	13,3	
	C_Vp_50%	2	5	91	557	603	73	648		228	0,6%	48,6%	2,61	23,5	0,8	13,1	
				44	638	608	74	654		229	1,2%	49,0%	0,84	32,0	0,8	13,1	
				70	610	603	73	648		228	1,6%	49,1%	2,00	19,6	0,8	13,1	
				64	615	603	73	648		228	1,4%	49,0%	2,00	25,1	0,8	13,1	
				50	909	856	104	920		323	0,9%	48,8%	0,66	39,0	0,8	13,1	
C_Vp_70%	2	5	120	847	362	44	389		327	0,3%	69,1%	2,64	27,1	0,1	12,3		
			107	816	362	44	389		343	0,4%	69,1%	1,74	36,7	0,1	12,3		
			65	866	367	45	395		347	0,6%	69,2%	0,71	56,5	0,1	12,3		
M_Air	M_Air_3%	2	-	53	144	1480				258	2,0%	37,8%	0,37	52,9	0,6	2,4	
				94	109	1480				258	3,0%	38,5%	1,33	25,9	0,6	2,4	
				81	121	1480				258	3,3%	38,6%	0,97	31,8	0,6	2,4	
	M_Air_15%	2	-	179	35	1480			0,20	258	10,1%	43,0%	3,52	19,1	0,6	2,4	
				179	35	1480			0,23	258	14,5%	45,8%	2,06	22,7	0,6	2,4	
				61	138	1480			0,34	258	14,7%	45,8%	0,31	84,2	0,6	2,4	
				128	79	1480			0,19	258	15,6%	46,4%	1,26	35,7	0,6	2,4	
				99	104	1480			0,19	258	15,6%	46,4%	0,96	40,0	0,6	2,4	
	M_Air_21%	2	-	123	84	1480			0,58	258	19,6%	49,0%	1,28	39,3	0,6	2,4	
				179	35	1480			0,46	258	20,1%	49,3%	2,01	29,8	0,6	2,4	
				144	65	1480			0,64	258	20,6%	49,6%	1,46	38,5	0,6	2,4	
				61	138	1480			0,59	258	19,8%	49,1%	0,31	108,8	0,6	2,4	
M_Air_29%	2	-	179	35	1480			0,92	258	24,1%	51,8%	1,71	35,8	0,6	2,4		
			194	22	1480			1,59	258	26,4%	53,3%	1,90	31,6	0,6	2,4		
			179	35	1480			1,59	258	26,9%	53,6%	1,63	44,7	0,6	2,4		
C_Air	C_Air_2%	2	5	The same mixes as the family C_Vp_30% were used													
	C_Air_11%	2	5	118	30	856	104	920	0,26	238	9,9%	35,6%	1,41	24,7	4,5	13,6	
				78	65	856	104	920	0,11	197	10,3%	33,2%	1,09	32,6	4,5	13,6	
				53	87	856	104	920	0,16	197	10,8%	33,5%	0,38	42,8	4,5	13,6	
				130	20	856	104	920	1,49	197	11,3%	33,9%	2,88	20,7	4,5	13,6	
				101	45	856	104	920	0,26	238	11,4%	36,6%	1,17	25,3	4,5	13,6	
				60	81	856	104	920	0,20	197	11,5%	34,1%	0,64	40,0	4,5	13,6	
	C_Air_17%	2	5	145	7	856	104	920	0,62	197	12,8%	35,0%	2,62	18,7	4,5	13,6	
				98	47	856	104	920	0,62	197	13,0%	35,2%	1,29	29,0	4,5	13,6	
				130	20	856	104	920	1,49	197	16,5%	37,8%	1,89	24,7	4,5	13,6	
				115	33	856	104	920	0,62	197	17,9%	38,8%	1,21	32,2	4,5	13,6	
	C_Air_25%	2	5	60	81	856	104	920	0,50	197	16,3%	40,1%	0,31	55,6	4,5	13,6	
				60	81	856	104	920	1,00	197	23,3%	42,9%	0,29	92,2	4,5	13,6	
				60	81	856	104	920	3,00	197	21,5%	44,2%	0,27	96,2	4,5	13,6	
				175	0	856	104	920	1,49	197	25,4%	44,8%	1,63	29,9	4,5	13,6	
				110	37	856	104	920	1,49	197	25,8%	44,7%	0,50	50,7	4,5	13,6	
				209	0	856	104	920	1,49	197	26,5%	46,2%	1,74	23,9	4,5	13,6	



Table 3 details all the mixes tested for the study of the parameters “aggregates strength”, “maximum diameter” and “CA/S ratio”. The clusters of mixes were named as follow:

- M or C for mortars or concrete;
- YY characterizing the parameter to be studied (FS: sand friability; LA: Los Angeles value; D<sub>90</sub>: diameter where 90% of the complete grading curve is passing; CAS: CA/S ratio);
- G1 and G3 are the different fraction of the gravel used for the mix, in size order, V<sub>p</sub>=paste volume without air; W=efficient water.

The name of the families is a concatenation of the cluster name and XX referring to the volume of the parameter YY studied

Table 3 – Proportions and characteristics of the mixes of the parameters “aggregates strength”, “maximum diameter” and “CA/S ratio”. Masses are given for dry aggregates.

Cluster	Family	Sand n°	Gravel n°	C	F	S	G1	G2	AEA	W	Air	Vp	R <sub>c28</sub>	Epc350	D50	D90	
				[kg]	[kg]	[kg]	[kg]	[kg]	[kg]	[kg]	[kg]	[%]	[%]	[MPa]	[mm]	[mm]	[mm]
M_FS	MFS_21	1	-	42	155	1500			0,16	237	14,5%	44,2%	0,48	54,8	0,5	1,9	
				54	144	1500			0,16	237	14,6%	44,2%	0,38	70,2	0,5	1,9	
				70	130	1500			0,16	237	10,7%	41,7%	0,79	47,4	0,5	1,9	
				112	93	1562			0,16	239	9,4%	40,2%	2,06	25,7	0,5	1,9	
	M_FS_27	2	-	The same mixes as the family M_Air_15% were used													
	MFS_62	3	-	80	122	1500			0,18	258	19,9%	47,2%	0,37	84,3	0,6	3,7	
				120	86	1500			0,10	258	22,5%	48,9%	0,91	55,3	0,6	3,7	
80				122	1500				258	17,7%	45,7%	0,74	53,7	0,6	3,7		
120				86	1500				258	21,4%	48,2%	1,54	33,9	0,6	3,7		
C_LA	CLA_7	2	4	30	124	879	908			182	3,8%	28,9%	0,41	51,7	3,0	11,8	
				60	98	879	908			182	3,1%	28,4%	1,61	26,6	3,0	11,8	
				90	72	879	908			182	3,2%	28,4%	3,84	18,0	3,0	11,8	
	CLA_20	2	5	30	124	879	528	420		207	2,8%	29,3%	0,25	53,6	3,4	12,2	
				90	72	879	528	420		207	2,9%	29,4%	2,47	19,2	3,4	12,2	
				60	98	879	528	420		207	2,9%	29,4%	0,87	30,1	3,4	12,2	
	CLA_40	2	6	30	124	879	975			188	4,3%	28,6%	0,40	55,0	3,5	12,0	
				43	113	879	975			183	6,4%	30,2%	0,71	41,8	3,5	12,0	
				68	91	879	975			188	5,9%	30,2%	1,95	23,9	3,5	12,0	
	CLA_50	2	7	30	124	879	580	390		204	2,7%	26,4%	0,32	60,2	3,2	14,4	
				60	98	879	580	390		204	3,4%	27,0%	1,04	31,4	3,2	14,4	
				90	72	879	580	390		204	3,4%	27,0%	2,82	19,6	3,2	14,4	
C_D90	C_D90_4	2	5	40	99	1800				284	6,2%	36,7%	0,19	114,9	0,7	2,4	
				80	64	1800				284	5,4%	36,1%	0,53	49,3	0,7	2,4	
				120	29	1800				284	5,0%	35,9%	1,18	30,9	0,7	2,4	
	C_D90_10	2	5	30	108	856	1030			217	7,3%	32,3%	0,17	71,8	4,4	9,7	
				60	82	856	1030			217	5,4%	30,9%	0,76	36,8	4,4	9,7	
				90	55	856	1030			217	5,1%	30,7%	2,30	22,9	4,4	9,7	
	C_D90_14	2	5	The same mixes as the family C_Air_11% were used													
	C_D90_20	2	5	30	108	856	104	220		167	7,4%	28,9%	0,40	47,5	5,5	18,4	
				60	82	856	104	220		167	7,6%	29,0%	1,48	20,6	5,5	18,4	
90				55	856	104	220		167	6,2%	27,9%	3,60	15,4	5,5	18,4		
C_CAS_0	2	-	The same mixes as the family M_Air_15% were used														
C_CAS_0,3	2	5	40	99	1440	42	393			230	9,0%	34,4%	0,33	75,3	0,9	12,0	
			75	69	1440	42	393			230	8,0%	33,7%	1,14	42,3	0,9	12,0	
			110	38	1440	42	393			230	6,8%	32,8%	2,57	27,1	0,9	12,0	
C_CAS_0,6	2	5	30	108	1170	72	635			211	9,0%	33,2%	0,27	85,1	1,4	13,0	
			60	82	1170	72	635			211	10,4%	34,2%	0,99	39,3	1,4	13,0	
			90	56	1170	72	635			211	11,6%	35,1%	2,21	25,0	1,4	13,0	
C_CAS_0,9	2	5	30	108	990	91	798			177	7,2%	29,4%	0,32	56,8	2,2	13,4	
			60	82	990	91	798			177	7,9%	29,9%	1,29	29,6	2,2	13,4	
			90	56	990	91	798			182	7,9%	30,3%	3,18	19,7	2,2	13,4	
C_CAS_1,2	2	5	The same mixes as the family C_Air_11% and C_D90_4 were used														
C_CAS_1,5	2	5	30	108	753	114	1015			178	10,2%	31,7%	0,27	51,2	8,1	13,7	
			60	82	753	114	1015			178	9,4%	31,1%	0,91	27,8	8,1	13,7	
			90	56	753	114	1015			178	9,7%	31,4%	1,19	26,7	8,1	13,7	

The same paste volume and air content were aimed at within each cluster. Others parameters were constant depending on the cluster:

- In the C\_LA cluster, the same sand but different coarse aggregates displaying different Los Angeles values were used. Yet care was taken to keep very similar skeleton grading curves.
- In the same way for the M\_FS cluster, even if different sands were used to have a wide range of friability values only slight differences of grading curves were observed.
- The same nature of aggregates was used within the C\_D90 cluster containing 3 lean concrete with different maximum coarse aggregates sizes. A mortar was also added to the analysis.
- The same nature of aggregates was used within the C\_CAS cluster. Figure 5 is presenting the different grading curves obtained for the different CA/S ratio.

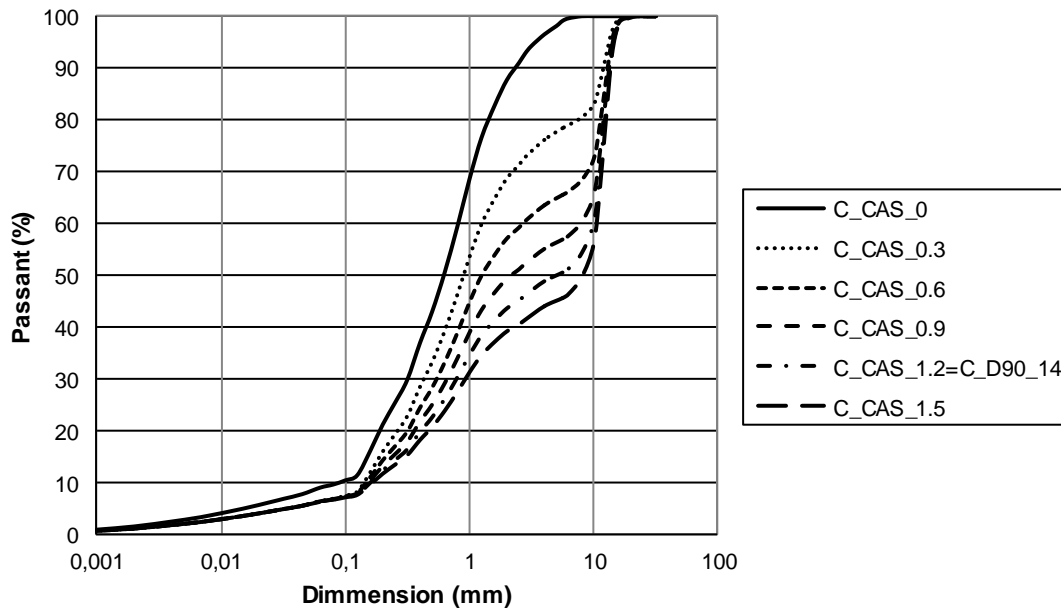

Figure 5 – Grading curves of concretes used to study the influence of the CA/S ratio

For each mix, a 50 liters batch was produced from which the following specimens were cast:

- 3  $\emptyset 16 \times 32 \text{ cm}^3$  cylinders for unconfined compressive strength tests ;
- 6  $\emptyset 16 \times 16 \text{ cm}^3$  cylinders for the punching tests.

The specimens were cast using a modified Glanville (BS 1881-103, 1983) apparatus consisting in a reversed metallic truncated cone (upper diameter: 254 mm – lower diameter: 127 mm – height: 227 mm) The bottom of the cone is equipped with a hatch (Ifsttar et Engie, 2016) and is set 20 cm from the top of the mold. The material is first poured in the cone. Then the hatch is opened and the material flows on its own weight into the mold. This method enables a repeatable casting of CLSM with no influence of the operator.  $\emptyset 16 \times 32 \text{ cm}^3$  plastic molds (for lean concrete),  $\emptyset 16 \times 32 \text{ cm}^3$  cardboard molds (for mortars) or  $\emptyset 16 \times 16 \text{ cm}^3$  metallic molds were used, all closed by a plastic cover and stored at 20°C. All the presented data were measured at 28 days and the punching test penetration measured at the energy of 350 J.



Figure 6 – Glanville apparatus

### 3.2. RESULTS

All the results of punching test penetration at 350J ( $E_{pc350}$ ) were then plotted vs unconfined compressive strength ( $R_c$ ) on different  $E_{pc} - R_c$  curves gathering the families of mixes per studied parameter. As it can be seen on Figure 7 for “paste volume mortars”, for each value of paste volume, the data can be satisfactorily fitted with curves according to the following type of equation:

$$E_{pc} = \alpha \cdot R_{c28}^{\beta} \quad \text{with } \alpha \text{ and } \beta \text{ constant for a given family of mixes} \quad (5)$$

Such a good fitting was also obtained for the other parameters studied and the evolution of  $\alpha$  and  $\beta$  then describe the marginal effect of the other parameters. With this method, it was possible to estimate the influence of a parameter on the penetration.

For example, Figure 7 compares the punching test penetration at 350 J versus the unconfined compressive strength for the mortar presenting different paste volume.

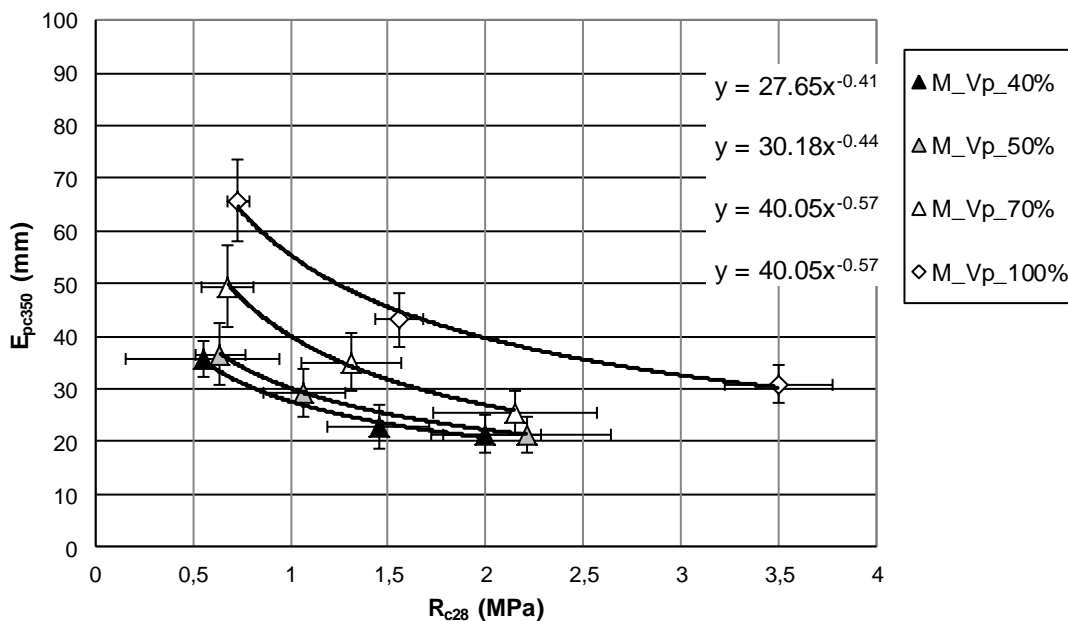

Figure 7 – Punching test penetration at 350 J ( $E_{pc350}$ ) versus unconfined compressive strength at 28 days ( $R_{c28}$ ) for mortars with different paste volumes from cluster M\_VP

As it appeared above, the paste volume is an important influencing parameter of the penetration: the higher the paste volume, the easier the penetration. This state of fact was observed on mortars as well as on lean concrete, with the same level of influence. Moreover it appears that the influence of paste volume is independent of the  $R_c$ . A similar observation was made on lean concrete.

A detailed presentation of all the results can be found in (Gennesseaux, 2015).

#### 4. RESULTS, ANALYSIS AND PREDICTION MODEL OF THE PUNCHING TEST PENETRATION

From the experimental campaign described above, a large database of mixes is available. The following model was consequently proposed to predict the penetration at 350J:

$$E_{pc350} = \left( 25 \cdot V_{p.without.air}^4 + 1567 \cdot \frac{V_{air}^{2.76}}{R_c \cdot \sqrt{\max(D_{90}; 1,5)}} - 21 \cdot \sqrt{\frac{D_{50}}{D_{90}}} + 41.27 \right) \cdot R_c^{-0.5} \quad (6)$$

Where  $V_{p.without.air}$  is the dimensionless paste volume ratio without the air entrained (i.e. the volume of cement, filler and water divided by the overall volume of mix),  $V_{air}$  is the dimensionless air-entrained volume ratio.;  $D_{50}$  and  $D_{90}$  are the diameters in mm enabling 50% (respectively 90%) of the complete grading curve (including the fine elements of the mixture) to pass through;  $R_c$  is the unconfined compressive strength (in MPa) at the moment of the penetration test.

In the model, the ratio CA/S is traduced by a parameter  $D_{50}/D_{90}$ , judged closer to the description of the grading curve.

The constants were optimized by minimizing the mean-square error of the model. The equation confirms the negative role of compressive strength on pick penetration but it also shows the positive effect of paste volume and the expected positive effect of air entrainment, even if the latter is decreasing with strength and  $D_{90}$ . Finally, a discontinuous aggregate curve seems to have also a marginal positive effect.

Figure 8 compares the theoretical punching test penetration at 350J calculated with the previous model versus the experimental data collected during all the collaboration ENGIE/Ifsttar. A satisfying correlation is obtained with an absolute error of 4.7 mm, which is two times lower than the width of the "difficult" area of the abacus in Figure 4, enabling a sufficient excavatability levels differentiation. This error is also implying an error on the theoretical volume, which is lower than the error given by Equations (1) and (2) in the prismatic model (5.6 L).

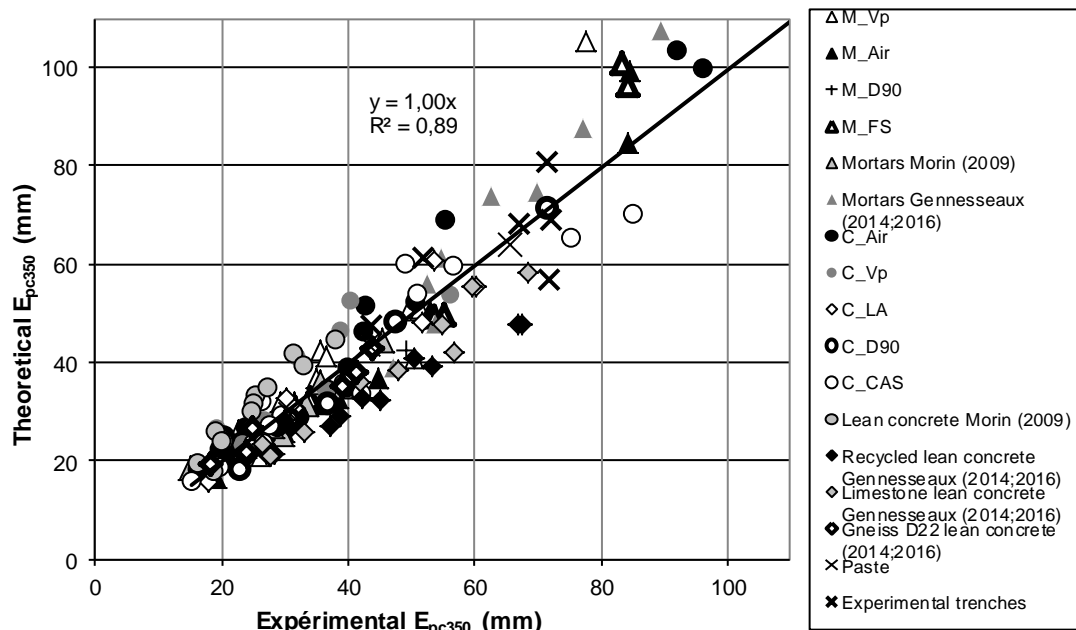

Figure 8 – Prediction of the punching test penetration model for all the mixes tested. Experimental data from this study and from (Morin, 2009; Genesseeaux, 2015)

## 5. CONCLUSIONS

The present paper aims at identify the mix design parameters influencing the excavatability of CLSM for trenches. Based on a new laboratory punching test presented at the beginning of the paper, allowing the prediction of the in-situ excavation depth to be obtained with a pick, a large parametric campaign is realized in order to optimize the mix design of such materials.

Using this data base, a model is proposed, allowing the prediction of the penetration of a pick in a cementitious material with a mean accuracy of 4.7 mm, for a given impact energy. Coupled with a geometrical model describing the excavation process, it is then possible to calculate the volume excavated (directly correlated to the difficulty of manual excavation) for a given number of pick impacts from some easy-to-obtain mix design parameters: the unconfined compressive strength, the air content, the paste volume and the grading curve.

It is now possible to introduce the presented method into a general optimization method aiming at designing excavatable cement treated materials.

The long-term unconfined compressive strength has yet to be studied as excavation generally occurs at advanced ages of the materials.

## REFERENCES

- Bonnet, G., Gavalda, A., & Quibel, A. (1998). Remblayage des tranchées, Utilisation de matériaux autocompactants. Etat des connaissances (Back filling of trenches, the use of self-compacting concrete - State of the art). In Dossier Certu, n°78, in French.
- ACI-229R-99, 1999. Controlled Low Strength Material, Farmington Hills, Michigan: American Concrete Institute 229R-99.
- BS 1881-103, 1983. Testing concrete. Method for determination of compacting factor.
- CERTU, 1998. Bonnet, G., Galvada, A., et Quibel, A. Remblayage des tranchées; utilisation de matériaux autocompactants. Etats des connaissances (Trench filling with flowable cementitious material. State of the art) Dossier Certu, in French.
- Crouch, L. et al., 2003. LongTerm Study of 23 Excavatable Tennessee Flowable Fill Mixtures - ASTM- STP 1459. p. 89.
- Crouch, L., Gamble, R., Brogdon, J. & Tucker, C., 1998. Use of High fines Limestone Sreening as aggregate for CLSM. The design and Application of CLSM (Flowable fill), Volume ASTM 1331, pp. 45-59.

Genesseaux, E., 2015. Excavabilité et formulation des matériaux traités aux liants hydrauliques pour tranchées (Excavatability and mix design of cementitious materials for trench), PhD Thesis, ed. Ecole Centrale de Nantes, in French.

Halmen, C., 2005. Physiochemical characteristics of controlled low strength materials influencing the electrochemical performance and service life of metallic materials (Dissertation), Texas A&M University, College Station, TX.

Hamcin, 1996. A Performance Specification for Controlled Low Strength Material Controlled Density Fill (CLSM-CDF), Hamilton County and the City of Cincinnati.

Ifsttar et Engie, 2016. Evaluation de l'excavabilité à la pioche des matériaux granulaires traités avec un liant hydraulique à l'aide d'un essai de poinçonnement (Evaluation of the excavatability with a pick of granular materials treated with hydraulic binder with the help of a punching test), Techniques et méthodes, GTI3, ed Ifsttar, Marne La vallée, in French.

Krell, W., 1989. Flowable fly ash. *Concrete International*, 11(11), pp. 54-58.

Morin, 2009. Etude de l'excavabilité des matériaux traités aux liants hydrauliques (Study of cementitious material excavatability), PhD Thesis, ed. Université Pierre et Marie-Curie de Paris, in French.

Morin, C. et al., 2013. Prediction of the volume of concrete backfill materials excavated using a pick. *European Journal of Environmental And Civil Engineering*, 17(10), pp. 935-955.

Morin, C. et al., 2017. Development of an Excavatability Test for Backfill Materials, Numerical and Experimental Studies. *Canadian Geotechnical Journal*, Issue DOI: 10.1139/cgi-2016-0534.

NCHRP, 2008. Development of a Recommended Practice for Use of Controlled Low-Strength Material in Highway Construction. TRB: Report 597.

Pons, F., Landwehrmeyer, J. & Kerns, L., 1998. Development of engineering properties for regular and quick-set flowable fill.. pp. 67-86.

Webb, M., McGarth, T. & Selig, E., 1998. Field test of buried pipe with CLSM backfill. *The Design and Application of Controlled Low Strength Materials (Flowable Fill)*, ASTM STP 1331. ed. American Society for Testing and Materials, pp. 237-254.