



**HAL**  
open science

## Ultra-High Temperature Ceramics : Developments for hypersonic applications

Jean-François Justin, Aurélie Julian-Jankowiak, Vincent Guérineau, Virginie Mathivet, Antoine Debarre

► **To cite this version:**

Jean-François Justin, Aurélie Julian-Jankowiak, Vincent Guérineau, Virginie Mathivet, Antoine Debarre. Ultra-High Temperature Ceramics : Developments for hypersonic applications. CEAS Aeronautical Journal, 2020, 10.1007/s13272-020-00445-y . hal-02778206

**HAL Id: hal-02778206**

**<https://hal.science/hal-02778206>**

Submitted on 4 Jun 2020

**HAL** is a multi-disciplinary open access archive for the deposit and dissemination of scientific research documents, whether they are published or not. The documents may come from teaching and research institutions in France or abroad, or from public or private research centers.

L'archive ouverte pluridisciplinaire **HAL**, est destinée au dépôt et à la diffusion de documents scientifiques de niveau recherche, publiés ou non, émanant des établissements d'enseignement et de recherche français ou étrangers, des laboratoires publics ou privés.



## Ultra-High Temperature Ceramics : Developments for hypersonic applications

*Jean-François Justin<sup>1</sup>, Aurélie Julian-Jankowiak<sup>2</sup>, Vincent Guérineau<sup>3</sup>,  
Virginie Mathivet<sup>4</sup>, Antoine Debarre<sup>5</sup>*

### Abstract

Ultra-High Temperature Ceramics are good candidates to fulfil the harsh requirements of hypersonic applications. For more than a decade, The Materials and Structures Department (DMAS) of ONERA has been actively involved in several programs to develop such materials for different applications (hypersonic flights, propulsion systems ...). In our laboratories, monolithic and composite materials have been investigated as well as several processing methods. In this paper, we present for example the ZrB<sub>2</sub>-SiC and HfB<sub>2</sub>-SiC compositions with TaSi<sub>2</sub> or Y<sub>2</sub>O<sub>3</sub> additions which have been especially studied in the European Projects ATLLAS and ATLLAS II. Assessments of several prototypes in realistic environment are also described. Furthermore, based on these material developments, a specific study on the oxidation behaviour of such monoliths from 1200°C to 2400°C with a dedicated test bench using a 2 kW CO<sub>2</sub> laser has been carried out (oxidation under air and water vapour atmospheres). Recently, some work on the manufacturing of Ultra-High Temperature Ceramic Matrix Composites has been initiated using slurry infiltration and pyrolysis. The behaviour and properties of these materials are encouraging.

**Keywords** : Ultra-High Temperature Ceramics, Leading Edges, Injectors, Ceramic Matrix Composite

### Acknowledgments

A part of this work was carried out within two projects investigating high-speed transport: *Aerodynamic and Thermal Load Interactions with Lightweight Advanced Materials for High Speed Flight* and *Aero-Thermodynamic Loads on Lightweight Advanced Structures II*. These studies were coordinated by ESA-ESTEC (J. Steelant) and supported by the EU within the 6<sup>th</sup> and 7<sup>th</sup> Framework Programmes. Thank you to M. Kuhn (DLR) and M. Bouchez (MBDA) for their collaboration on the development and testing of the hybrid injector.

---

<sup>1</sup> ONERA / DMAS, Université Paris-Saclay, F-92322 Châtillon, France, [Jean-Francois.Justin@onera.fr](mailto:Jean-Francois.Justin@onera.fr), +33 146734515

<sup>2</sup> ONERA / DMAS, Université Paris-Saclay, F-92322 Châtillon, France, [Aurelie.Jankowiak@onera.fr](mailto:Aurelie.Jankowiak@onera.fr), +33 146734459

<sup>3</sup> ONERA / DMAS, Université Paris-Saclay, F-92322 Châtillon, France, [Vincent.Guerineau@onera.fr](mailto:Vincent.Guerineau@onera.fr),

<sup>4</sup> ONERA / DMAS, Université Paris-Saclay, F-92322 Châtillon, France, [Virginie.Mathivet@onera.fr](mailto:Virginie.Mathivet@onera.fr), +33 146734530

<sup>5</sup> ONERA / DMAS, Université Paris-Saclay, F-92322 Châtillon, France, [Antoine.Debarre@onera.fr](mailto:Antoine.Debarre@onera.fr), +33 146734637

## Nomenclature :

ATLLAS	Aerodynamic and Thermal Load Interactions with Lightweight Advanced Materials for High Speed Flight
ATLLAS II	Aero-Thermodynamic Loads on Lightweight Advanced Structures II
BLOX4	4 <sup>th</sup> laser oxidation analysis facility
C/C-SiC	Carbon fibre reinforced silicon carbide composite
CMC	Ceramic Matrix Composites
CTE	Coefficient of Thermal Expansion (in $10^{-6} \text{ }^{\circ}\text{C}^{-1}$ )
CVI	Chemical Vapor Infiltration
DGA	Directorate General of Armaments
DLR	Deutsches Zentrum für Luft- und Raumfahrt
EDM	Electrical Discharge Machining
EDS	Energy Dispersive Spectroscopy
ESA-ESTEC	European Space Agency - European Space Research and Technology Centre
FAST	Field Assisted Sintering Technology
HP	Hot Pressing
PCS	Poly-Carbo-Silane (SiC precursor)
PIP	Precursor Infiltration and Pyrolysis
PyC	Pyrolytic Carbon
RMI	Reactive Melt Infiltration
SEM	Scanning Electron Microscopy
SI	Slurry Infiltration
SIP	Slurry Infiltration and Pyrolysis
SPS	Spark Plasma Sintering
TT	Thermal Treatment
UHTCs	Ultra High Temperature Ceramics
UHTCMCs	Ultra High Temperature Ceramic Matrix Composites
WC	Tungsten Carbide
$\rho$	Density (in $\text{g/cm}^3$ )
$\sigma_f$	Bending flexural strength (in MPa)
$\epsilon_f$	Flexural strain (in %)
$d_{50}$	Median particle size (in $\mu\text{m}$ )
E	Young's Modulus (in GPa)
$E_f$	Flexural Modulus (in GPa)
$K_{1C}$	Fracture toughness (in $\text{MPa}\cdot\text{m}^{1/2}$ )
$H_v$	Hardness (in GPa)

## 1. Introduction

Hypersonic flights, re-entry vehicles and propulsion applications all require new materials that can perform in oxidising or corrosive atmospheres at temperatures superior to 2000°C and sometimes over the course of a long working life. For re-entry vehicles and hypersonic aircraft or missiles, external parts like nose, vertical fins, wing leading edges or flaps are submitted to very high heat fluxes along the flight [1]. These high heat fluxes are also present for some internal components used for propulsion: injectors, vanes, engine inlets and exits, etc. In addition, for hypersonic vehicles, performance improvement (lift-to-drag ratio in particular) requires slender aerodynamic shapes with sharp leading edges. However, the thinner the leading edge radius, the higher the temperature [2-3]. To illustrate the friction heating of the outer walls of a hypersonic aircraft, a representation at cruise Mach number of 5 of the external temperatures of the conceptual transport vehicle studied in the ATLLAS II project is provided in Fig 1 [4]. At this moderated hypersonic speed, the average surface temperature is already around 1200-1300K, with raises up to about 1800K on part of the leading edge close to the engine nacelles. These temperatures would be even higher with extremely thin leading edges (radius < 1 mm). Thus, temperatures well in excess of 2300K are currently announced on advanced hypersonic vehicles.

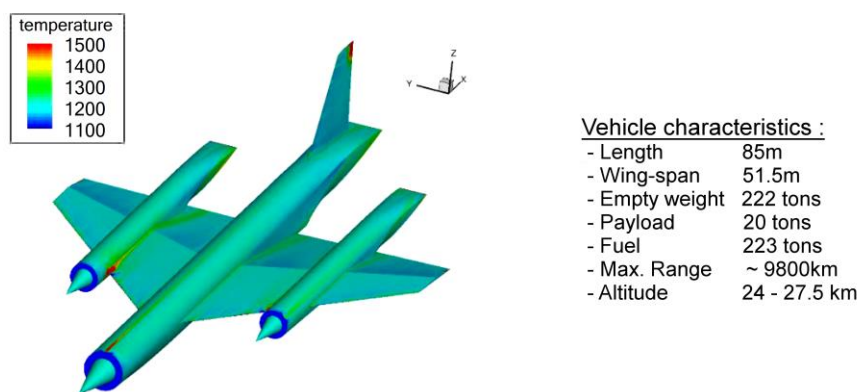

**Fig 1.** ATLLAS II vehicle : surface temperature for Mach 5 (in K) and a few characteristics

In this context, the field of possible materials is limited. Several studies [5-9] have revealed that Ultra-High Temperature Ceramics are particularly interesting to meet the thermomechanical and thermochemical stresses generated on the sharp components (wing leading edges, air intakes, vertical fins) of vehicles flying at hypersonic speeds ( $\gg$  Mach 5). Indeed, with these operating conditions (oxidising environment and temperature above 2000K notably), current high temperature structural materials such as C/C composites, SiC or Si<sub>3</sub>N<sub>4</sub> based compounds are not sufficient.

UHTCs are compounds made of borides, carbides and nitrides such as ZrB<sub>2</sub>, HfB<sub>2</sub>, ZrC, HfC, TaC, HfN which are characterised by high melting points (Table 1), high hardness, chemical inertness and relatively good resistance to oxidation in severe environments.

UHTC materials have been studied since the 1960s, however a resurgence of activity appeared in the early 2000s to meet the needs of future hypersonic vehicles. Detailed histories of the work carried out on this family of materials have been presented in several documents [7-9]. It is important to specify that single-phase UHTCs are not suitable for high-temperature structural applications given their low resistance to oxidation and ablation. That's why work turned to compounds with several refractory phases. Thus, for diborides for example, many additives such as Nb, V, C, disilicides and SiC were evaluated to improve their resistance to oxidation. Among these additives, SiC seemed to be particularly valuable and 20 vol. % was judged optimal for hypersonic vehicles by several laboratories [11-15]. So, in recent years, many studies have been carried out throughout the world on the development, characterisation and optimisation of these UHTCs (oxidation resistance, manufacturing processes, etc.) [5-6,15-25]. However, the use of monolithic ceramics for high temperature structural applications is limited by some disadvantages (low fracture toughness notably). As a result, only applications using small, correctly designed and assembled components seem to be possible [4,24]. Consequently, in parallel, considerable efforts have been made in recent years to develop new composite materials combining a UHTC matrix and different types of reinforcement (whiskers and fibres in particular). Currently, many research groups in the United States, Asia and Europe are studying UHTCMCs which are very promising materials [26-40]. Most of these composites are based on a continuous carbon fibre reinforcing phase.

Indeed, carbon fibres are currently the best reinforcement for use at ultra-high temperature with high specific strength and modulus, high stiffness and low CTE. In addition, numerous processing methods for UHTCMCs are under investigation (CVI, PIP, RMI, SIP, SPS, HP ...). So there's a wide variety of materials in development nowadays.

**Table 1.** Properties of some UHTCs [10]

<b>Material</b>	<b>Density (g/cm<sup>3</sup>)</b>	<b>Melting temperature (°C)</b>
HfB <sub>2</sub>	11.2	3380
HfC	12.8	3900
HfN	13.9	3385
ZrB <sub>2</sub>	6.1	3245
ZrC	6.6	3400
ZrN	7.3	2950
TiB <sub>2</sub>	4.5	3225
TiC	4.9	3100
TiN	5.4	2950
TaB <sub>2</sub>	12.5	3040
TaC	14.5	3800
TaN	14.3	2700

For a few years, the Materials and Structures Department of ONERA is involved in different projects concerning UHTC material developments (from manufacturing to thermomechanical assessments of components in realistic environment and oxidation resistance understanding). These studies has been achieved notably within the framework of researches for the DGA in France and for the European Community (European Programs ATLLAS and ATLLAS II) [4,10, 41-51]. Most of our work on monolithic ceramics has been carried out on diborides of the group IVb (ZrB<sub>2</sub> and HfB<sub>2</sub>) which possess very high melting points (> 3200°C), excellent thermomechanical properties and a good resistance to oxidation when SiC is introduced as additive. Moreover, in comparison with carbides and nitrides, diborides have also higher thermal and electrical conductivities, which give them a relatively good thermal shock resistance and a good machinability (by using EDM). This last point is appreciable for manufacturing complex shapes. However, due to the limitations in the use of monoliths, most of the current activity is focused on continuous fibre reinforced composites in which carbides based compositions have been preferentially investigated for the matrix (HfC with SiC notably). HfC was chosen for several reasons including: an extremely high melting temperature (3900°C), an oxide which also has a high melting temperature (2800°C), its good ablation resistance, its low vapour pressure, its good chemical inertness and its availability in small particle size powder (d<sub>50</sub> = 1.95 µm),

This paper presents a synthesis of the results collected on UHTC materials (monoliths and composites) in past and current studies. Several aspects are exposed and notably their manufacturing, their properties, their oxidation resistance and their assessment in realistic environments (arc-jet test, combustion chamber) ...

## **2. Materials manufacturing**

As mentioned previously, two main UHTC material families have been manufactured: monolithic ceramics and composites. Their properties are closely linked with the densification processes, compositions, starting raw materials, microstructures and so on.

### **2.1. Monolithic ceramics**

ZrB<sub>2</sub>-SiC and HfB<sub>2</sub>-SiC compositions with or without additives have been selected for our studies. Additives as TaSi<sub>2</sub> and Y<sub>2</sub>O<sub>3</sub> were used firstly to make the sintering process easier and secondly to enhance oxidation

resistance at high temperature. Commercially available  $ZrB_2$ ,  $HfB_2$ , SiC,  $TaSi_2$  and  $Y_2O_3$  powders were employed to manufacture the materials (Table 2).

**Table 2.** Grade, purity, particle size and measured density of starting powders

Powder	Grade / Supplier	Purity (%)	Particle size $d_{50}$ ( $\mu m$ )	Density ( $g/cm^3$ )
$ZrB_2$	Z-1031 / Cerac	99.5	8.2	5.97
	Grade B / H.C Starck	> 97.8	2.8	5.98
$HfB_2$	H-1002 / Cerac	99.5	2.0	10.85
	Grade A / H.C Starck	> 97.0	7.6	10.66
SiC	BF12 / H.C. Starck	> 98.5	0.6	3.15
$TaSi_2$	T-1016 / Cerac	99.5	6.5	9.02
$Y_2O_3$	Ampere Industrie	99.99	< 5.0	4.89

To obtain the selected compositions, starting powders were weighed according to their respective proportions and attrition milled in cyclohexane using  $ZrO_2$  or WC media. Then, the mixtures were dried in a rotary evaporator and sieved down to 50  $\mu m$  mesh size to avoid agglomeration. Finally, the powder blends were sintered in coated graphite dies (Papyex® + BN) by two different processes:

- Hot Pressing at Onera,
- Field Assisted Sintering Technology also known as Spark Plasma Sintering at ICB in Dijon (*FCT System GmbH, HP D 125*) and Mateis in Lyon (*FCT System GmbH, HP D 25*).

Powders from Cerac were used only for HPed samples. A synthesis of the sintering parameters of some studied compositions is reported in Table 3.

**Table 3.** Sintering parameters of several monolithic samples

Method	Sample size	Composition	Reference	Sintering parameters
<b>HP</b> (Onera)	68x68 mm <sup>2</sup> plates (maximum)	$ZrB_2/20vol\%$ SiC/20vol% $TaSi_2$	ZST-HP	1700°C/120min/27MPa/Argon
		$HfB_2/20vol\%$ SiC/20vol% $TaSi_2$	HST-HP	1800°C/120min/27MPa/Argon
		$ZrB_2/20vol\%$ SiC	ZS-HP	1800°C/120min/27MPa/Argon
<b>FAST</b> (Mateis)	Ø20 mm discs	$ZrB_2/20vol\%$ SiC	ZS-FAST1	2100°C/5min/7MPa/Argon
		$HfB_2/20vol\%$ SiC	HS-FAST1	2000°C/5min/7MPa/Argon
		$HfB_2/20vol\%$ SiC/3vol% $Y_2O_3$	HSY-FAST1	1880°C/5min/7MPa/Argon
<b>FAST</b> (ICB)	Ø60 mm discs (maximum)	$ZrB_2/7.5vol\%$ SiC	ZS-FAST2	2100°C/15min/50MPa/vacuum
		$HfB_2/20vol\%$ SiC	HS-FAST2	2100°C/15min/28MPa/vacuum
		$HfB_2/20vol\%$ SiC/3vol% $Y_2O_3$	HSY-FAST2	2000°C/15min/28MPa/vacuum

The FAST has the advantage of carrying out compaction, sintering and cooling with high temperature ramps (50°C/min or 100°C/min in these studies to be compared with 10°C/min for HP).

## 2.2. UHTC Composites

For UHTCMCs, as previously mentioned, materials based on carbides matrix reinforced with continuous carbon fibres have been preferentially investigated ( $C_f$  /  $HfC$  - 20 vol. % SiC in particular). Indeed, for these early manufacturing processes, hafnium carbide was preferred to diborides for various reasons, some of which are linked to the pre-selected manufacturing process: the pressure-assisted Slurry Infiltration and Pyrolysis method [33-34]. This process involves infiltration of a low-viscosity slurry into a fibrous preform followed by pyrolysis

of ceramic precursor to obtain the ceramic matrix. Obtaining slurries that meet the process specifications requires notably the use of extremely fine powders (of the order of 1  $\mu\text{m}$ ). This was the case with the HfC powder that we have pre-selected for our developments (ABCRC GmbH & Co,  $d_{50} = 1.95 \mu\text{m}$ ,  $12.2 \text{ g/cm}^3$ ).

Furthermore, this carbide has particularly interesting properties including a very high melting temperature ( $3900^\circ\text{C}$ ), an oxide that is also very refractory ( $2800^\circ\text{C}$ ), a good ablation resistance, a low vapour pressure and a good chemical inertness.

Finally, the selected raw materials for these composites were a 2D carbon fibre fabric (Toho Tenax HTA5131, 3K, twill weave  $2 \times 2$ ,  $282 \text{ g/m}^2$ ) for the reinforcement and a combination of HfC powder (H.C. Starck) plus SiC precursor (Starfire Systems SMP-10) for the matrix.

In order to correctly infiltrate the C preform, the attention has been focused on the optimisation of the slurry to obtain a high solid content ( $> 50 \text{ vol. } \%$ ) as well as a low viscosity ( $< 150 \text{ mPa}\cdot\text{s}$ ). Several infiltration procedures have been investigated: one step method (powder + precursor in the same slurry) or multi-step method (powder first and precursor after). Composites that were densified in one step were called **Composites A** and those obtained in several steps were called **Composites B**. For the infiltration phase, a specific metallic mould ( $40 \times 50 \text{ mm}^2$ ) has been used to place the carbon plies and set the final plate thickness (6 plies for  $\sim 2 \text{ mm}$  /  $V_f > 40 \text{ vol. } \%$  of the mould cavity). The infiltration is realised by applying vacuum on one side of the mould in order to suck the slurry located in a recipient connected to the other side of the assembly. The experiment is stopped when the slurry is seen on the side under vacuum.

After infiltration, samples are dried and hot pressed in graphite die (at  $1600^\circ\text{C}/24 \text{ MPa}/1\text{h}$ ) under flowing argon to fully transform the precursor in crystalline SiC.

### 3. Materials characterisation

Concerning the UHTC monoliths in particular, a thorough characterisation of their properties has been achieved in several studies and notably for the European Community in the framework of the European Programs ATLLAS and ATLLAS II. These European projects included various tasks dealing with quite different topics, some of which related to the investigation of specific materials for a hypersonic transport aircraft. These projects and their most significant results are presented in several documents [4,10,41-48]. Concerning the materials developed at ONERA, several aspects have been studied: microstructure (X-Ray diffraction), chemical, physical, mechanical, thermal and optical properties (diffusivity, heat capacity, CTE, emissivity), machining behaviour, oxidation resistance in severe environment etc. Only a few of these data are reported in this paper. The bulk density and open porosity of materials were measured by the Archimedes' method. The level of densification was calculated as the ratio of the apparent density to the theoretical density. Each theoretical density used to evaluate the level of densification has been calculated by a rule of mixtures based on densities of each raw materials (theoretical values from literature). Microstructures were observed on polished cross-sections using a Scanning Electron Microscope equipped with EDS for local analysis. Bending flexural strength has been determined by three point flexural tests (test speed  $0.3 \text{ mm/min}$ , span of  $30 \text{ mm}$ ). Young's moduli were measured by impulse excitation of vibration on bars ( $\sim 35.1 \times 5.2 \times 2.1 \text{ mm}^3$ ) using a Grindosonic MK5 apparatus [52]. Hardness and fracture toughness were obtained on  $\frac{1}{4} \mu\text{m}$  polished surfaces by Vickers' indentation with a load of  $98 \text{ N}$ . The fracture toughness is estimated by crack length measurement of the radial crack pattern formed around Vickers indents [53]. Thermal expansion coefficients were determined up to  $1440^\circ\text{C}$  with a heating rate of  $5^\circ\text{C/min}$  under flowing argon ( $20 \text{ ml/min}$ ) using a SETSYS Evolution SETARAM dilatometer. The oxidation behaviour was studied from  $1200^\circ\text{C}$  to  $2400^\circ\text{C}$  with a specific test bench using a  $2 \text{ kW CO}_2$  laser under air and water vapour atmospheres.

#### 3.1. Monolithic ceramics properties

##### 3.1.1. Microstructure

Densification levels measured on all types of monoliths are superior to 96% of theoretical densities and open porosities lower than 1%. Microstructural aspects of these materials after HP or FAST are presented in Fig 2 and Fig 3. We can see that very fine microstructures are obtained with a good homogeneity and a small grain size. A finer microstructure is observed for TaSi<sub>2</sub>-containing materials due to a lower sintering temperature but also to the fact that this compound can act as a grain growth inhibitor. It is also interesting to note that for these materials, due to partial volatilisation of TaSi<sub>2</sub> during sintering, the final compositions of the monoliths must be slightly different from the target compositions. This is due to the reaction of TaSi<sub>2</sub> with the B<sub>2</sub>O<sub>3</sub> present on the surface of the diboride particles, which leads to the formation of SiO and BO and thus to mass losses estimated at about 3% for ZST and 7% for HST (in relation to the mass of powder introduced into the mould).

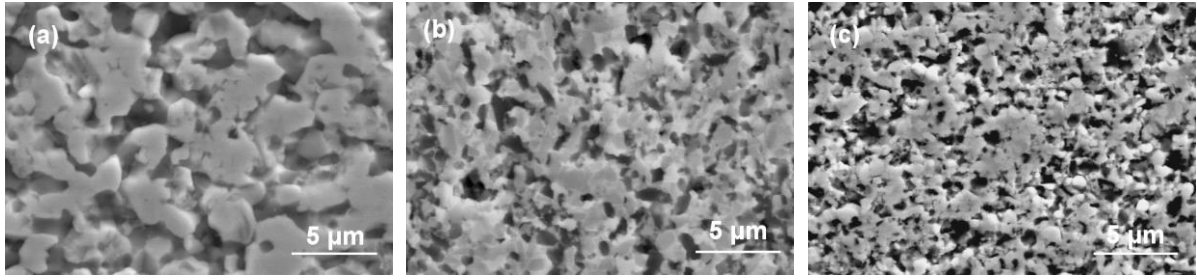

**Fig 2.** SEM micrographs of (a) ZrB<sub>2</sub>/20 vol. % SiC, (b) ZrB<sub>2</sub>/20 vol. % SiC/20 vol. % TaSi<sub>2</sub> and (c) HfB<sub>2</sub>/20 vol. % SiC/20 vol. % TaSi<sub>2</sub> monoliths densified by **HP** (in grey, ZrB<sub>2</sub> or HfB<sub>2</sub>; in black, SiC; in white, TaSi<sub>2</sub>)

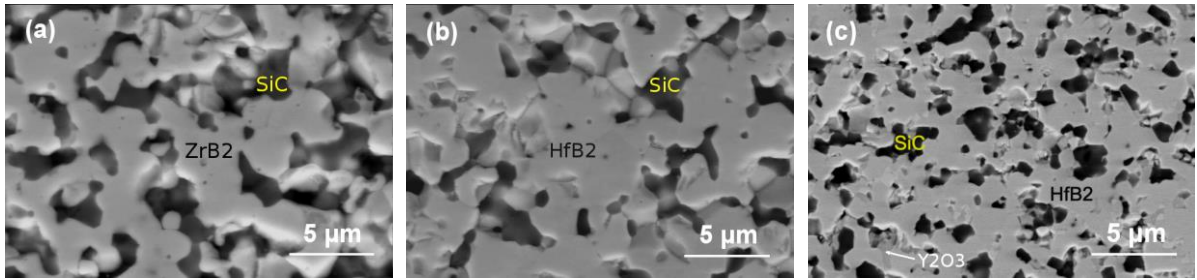

**Fig 3.** SEM micrographs of (a) ZrB<sub>2</sub>/20 vol. % SiC, (b) HfB<sub>2</sub>/20 vol. % SiC and (c) HfB<sub>2</sub>/20 vol. % SiC/3 vol. % Y<sub>2</sub>O<sub>3</sub> monoliths densified by **FAST**

### 3.1.2. Mechanical behaviour

Density and mechanical properties at room temperature as well as the CTE from 25 to 1300 or 1440°C, of several monolithic samples are reported in Table 4. The mechanical behaviour of these monoliths is really satisfactory. Moreover, it is important to notice that at high temperature some of these properties are sometimes even higher (Table 5) [10]. Indeed, we have observed that for materials comprising TaSi<sub>2</sub> for example, increasing temperature up to 1150°C leads to higher flexural stresses, a strong increase of flexural strains and a moderated decrease in the flexion modulus. It should be noted that flexural strength values over 1200 MPa have even been measured on HfB<sub>2</sub>/SiC/TaSi<sub>2</sub> samples at 1150°C which ranks these materials among the highest-strength UHTC monoliths [15,24,54-57].

**Table 4.** Density, Young's Modulus, bending flexural strength, fracture toughness, hardness and coefficient of thermal expansion of materials sintered by HP and FAST.

Monolith reference	$\rho$ (g/cm <sup>3</sup> )	E (GPa)	$\sigma_f$ (MPa)	K <sub>IC</sub> (MPa.m <sup>1/2</sup> )	H <sub>v</sub> (GPa)	CTE (.10 <sup>-6</sup> °C <sup>-1</sup> )
ZST-HP	5.95	446 ± 9	688 ± 79	4.4 ± 0.3	18.1 ± 0.4	7.3 (25-1300°C)
HST-HP	9.09	498 ± 6	869 ± 170	4.6 ± 0.2	18.1 ± 0.6	7.4 (25-1300°C)
ZS-HP	5.36	465 ± 15	451 ± 90	4.3 ± 0.2	20.9 ± 1.9	7.2 (25-1300°C)
ZS-FAST1	5.32	--	468 ± 147*	3.5 ± 0.7	15.3 ± 0.6	7.8 (25-1440°C)
ZS-FAST2	5.65	416 ± 3	584 ± 82	--	--	7.7 (25-1440°C)
HS-FAST2	9.19	479 ± 11	694 ± 91	6.7 ± 0.9	17.5 ± 0.3	7.4 (25-1440°C)
HSY-FAST2	9.04	489 ± 4	843 ± 110	3.9 ± 0.3	21.9 ± 1.1	7.5 (25-1440°C)

\*bi-axial flexural strength



**Table 5.** Evolution of bending flexural strength, flexural modulus and flexural strain of two materials sintered by HP as a function of temperature.

Monolith reference	Property	Test temperature		
		20°C	1000°C	1150°C
ZST-HP	$\sigma_f$ (MPa)	688 ± 79	801 ± 40	864 ± 96
	$E_f$ (GPa)	211 ± 13	181 ± 14	133 ± 13
	$\epsilon_f$ (%)	0.32 ± 0.02	0.45 ± 0.04	0.65 ± 0.02
HST-HP	$\sigma_f$ (MPa)	869 ± 170	882 ± 146	1055 ± 189
	$E_f$ (GPa)	245 ± 13	203 ± 24	178 ± 22
	$\epsilon_f$ (%)	0.36 ± 0.09	0.43 ± 0.05	0.56 ± 0.13

Globally, these materials exhibit interesting mechanical properties and they have been applied to manufacture prototypes and realistic components which have been tested (see § 4). However, regarding the fracture toughness of these monolithic ceramics, as predicted they are quite low and similar to that of common silicon nitride ( $K_{IC} \sim 3.5 - 6 \text{ MPa.m}^{1/2}$ ). Thus, as already mentioned, in order to also dispose of materials with higher toughness levels, a good part of the recent work has been oriented on UHTCMC. These composites could be associated later with other materials to be able to design new components.

### 3.1.3. Oxidation resistance

Since the first ATLLAS project, several test campaigns have been carried out in order to investigate the thermal and chemical resistance of the monoliths. Most of them were fulfilled with a homemade device (BLOX4) but also in more realistic conditions (close to hypersonic flight for example see § 4). BLOX4 is a facility used for oxidation tests at very high temperatures (up to 2500°C) in controlled atmospheres ( $\text{H}_2\text{O}$ , Ar,  $\text{N}_2$ ,  $\text{H}_2$ , air ...) at pressures ranging from few millibars to 4 bar. Heating of discs samples is ensured thanks to a  $\text{CO}_2$  laser (2 kW). Surface temperature of the monoliths is measured with two bicolor pyrometers. A schematic view of this device as well as a  $\varnothing 20$  mm disc sample ( $\text{HfB}_2/20\text{vol}\% \text{ SiC}/3\text{vol}\% \text{ Y}_2\text{O}_3$ ) before and during a test at 1800°C is presented in Fig 4.

In the framework of a recent PhD work three compositions densified by FAST, previously investigated in ATLLAS projects, have been specifically studied at very high temperature under oxidative atmosphere [49-50]:

- $\text{ZrB}_2/20 \text{ vol. } \% \text{ SiC}$  (labelled ZS-FAST1 or only ZS),
- $\text{HfB}_2/20 \text{ vol. } \% \text{ SiC}$  (labelled HS-FAST1 or only HS),
- $\text{HfB}_2/20 \text{ vol. } \% \text{ SiC}/3 \text{ vol. } \% \text{ Y}_2\text{O}_3$  (labelled HSY-FAST1 or only HSY).

In this work, all the tests were carried out at a total pressure of 1 bar, under an  $\text{H}_2\text{O}/\text{Ar}$  atmosphere (30/70 vol. % in Standard Liter). During these tests, once 1000°C is reached (laser power ramp), a temperature ramp of 5°C/s is imposed, allowing the sample to reach the target temperature (between 1200 and 2400°C) where a dwell time is applied before the temperature decrease at the same rate.

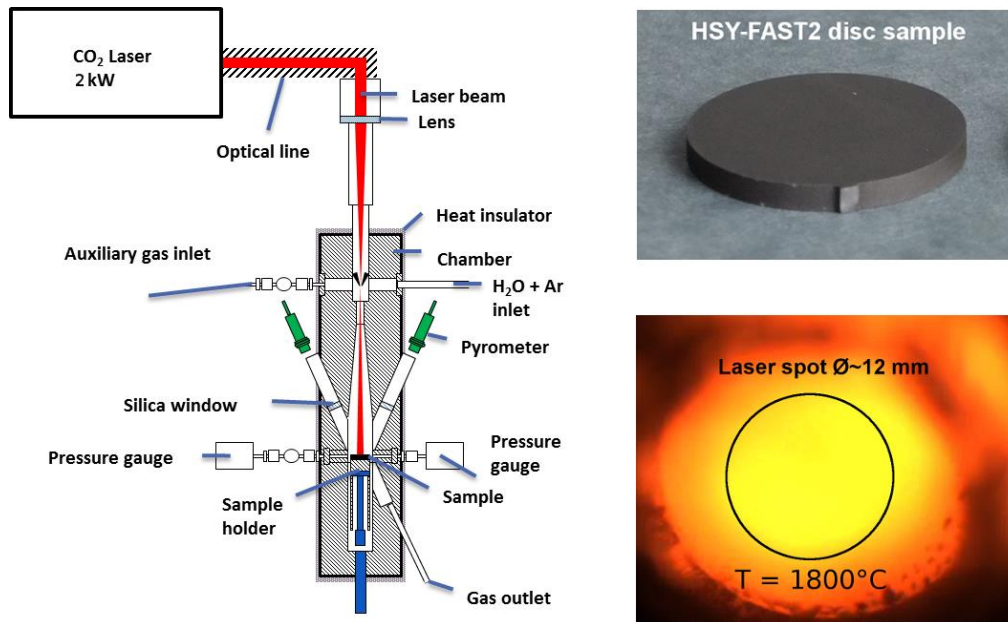

**Fig 4.** Schematic representation of the BLOX4 device, disc sample after machining and surface visualisation during a test at 1800°C

The behaviour of these compositions is greatly dependant on the test temperature as shown in Table 6 presenting the mass variations observed on the test specimens. An in-depth analysis of the mechanisms behind these observations was reported earlier [49-50]. A brief summary of the observed phenomena is provided below. For a dwell time of 20 s we have noticed the following results. Below 1500°C, very thin oxidised layers are formed (according to the initial composition, monoclinic  $\text{HfO}_2$  or  $\text{ZrO}_2$ ). At 1550°C, ZS, HS and HSY exhibit a two-layered oxide scale made of a glassy  $\text{SiO}_2$  rich layer on the top and beneath an  $\text{HfO}_2$  or  $\text{ZrO}_2$  layer. At 1900°C, a three-layered oxide scale is observed for all the compositions: a heterogeneously distributed glassy silica rich layer on the top, an  $\text{HfO}_2$  or  $\text{ZrO}_2$  layer and then a SiC-depleted  $\text{HfB}_2$  or  $\text{ZrB}_2$  layer. Moreover, some mechanical damages (non-cohesive lamellae) are observed on materials that do not contain  $\text{Y}_2\text{O}_3$ . At 2200°C, some mechanical issues are detected for ZS samples and a non-adherent oxide layer is present on HS. However, for HSY, oxide layers are still adherent even though the top  $\text{HfO}_2$  layer contains cracks. This good behaviour is due firstly to the monoclinic to tetragonal transition of  $\text{HfO}_2$  that is less preponderant in HSY than in HS and secondly to the creation of an  $\text{Y}_2\text{Si}_2\text{O}_7$  interphase (between  $\text{HfO}_2$  and the SiC-depleted  $\text{HfB}_2$  layer) that mitigates the thermal mismatch. At 2400°C, only HS has been investigated. For this composition, despite some mechanical damages, the  $\text{HfO}_2$  top layer exhibits evidence of sintering and might provide further resistance towards oxidation.

**Table 6.** Weight variations of oxidised samples as a function of temperature.

Monolith reference	1200°C	1550°C	1900°C	2200°C	2400°C
ZS-FAST1	+ 0.04%	+ 0.15%	0.00%	- 0.32%	---
HS-FAST1	+ 0.01%	+ 0.01%	- 0.08%	- 1.27%	- 1.57%
HSY-FAST1	+ 0.01%	+ 2.24%	- 0.28%	- 1.48%	---

### 3.2. UHTC Composites properties

It is important to notice that for composites the development phase is in progress and that several adjustments, on the composition and on the process, are always done. For example, a preliminary work on a Pyrolytic Carbon (PyC) fibre/matrix interphase has been carried out (not exposed in this paper). In this paper, the microstructures presented in Fig 5 are representative of two types of  $\text{C}_f/\text{HfC} - 20 \text{ vol. \% SiC}$  composites manufactured differently according to the information previously mentioned (§ 2.2). It should be note that one infiltration step has been applied to the labelled **Composite A** and two to the **Composite B**.

Both composites exhibit a fairly good matrix distribution between the plies however the infiltration process seems still imperfect. Moreover, a few voids and some small cracks are also visible. In fact, some yarns are not completely infiltrated by the slurry and notably their centres. Thus, despite the small grain size of the HfC powder, we can observe a partial filtration of the suspension by the fibres. It is not the case for the SiC precursor which is sufficiently liquid during the infiltration process to correctly penetrate inside the fibre tows. On the other hand, with the thermal treatment applied for densification and pyrolysis, there is no reaction occurring at the fibre/matrix interface which is a good point for further developments.

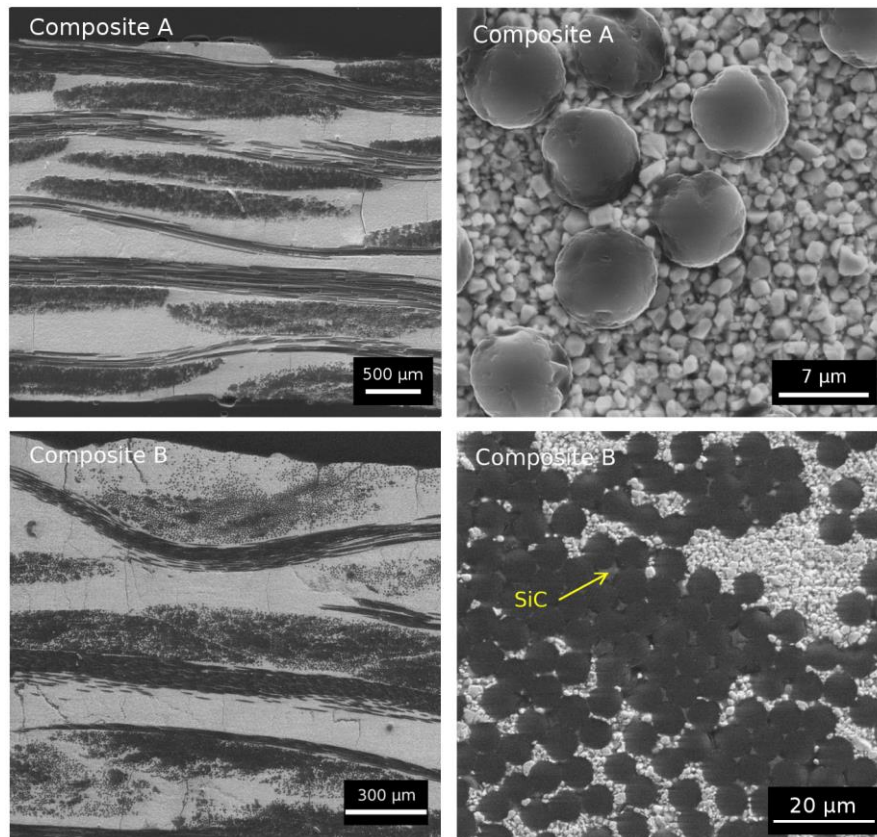

**Fig 5.** Microstructure of two Cf/HfC-SiC composites made by SIP

Several UHTCMC have been manufactured during this first development phase. For these materials, final density values are distributed between 5 and 6. No macro-pores are observed and the porosity is principally composed of small voids and cracks due to the final hot pressing phase (at 1600°C/24 MPa/1h). Indeed, this last step generates on the one hand a pyrolysis of the SiC precursor accompanied by a reduction in the volume occupied by this compound and on the other hand a change in the thickness of the material under the pressure applied. Finally, the open porosity level is still important (between 21 and 29 vol. %) for a fibre fraction estimated between 30 and 43 vol. %.

For these materials, current Young's moduli are around 50 GPa and bending flexural strength around 70 MPa. These values are rather low compared to the most significant results obtained on different types of UHTCMCs (Table 7). As a result, it is evident that some further work is necessary to optimise the densification step in order to decrease the porosity (several infiltrations, new infiltrations parameters, finer grain size ...). Another important improvement must be made in the selection and application of a suitable fibre/matrix interface in order to achieve a dissipative behaviour of the material. The contribution of this interphase on the mechanical performances is obvious. This improvement is particularly visible in Table 7 where mechanical properties are presented for the same nature of material with different type of interfaces.

**Table 7.** Room temperature properties of a few selected UHTCMC based on carbon fibres reinforcements.

Composites	Manufacturing process	Open porosity (%)	$\rho$ (g/cm <sup>3</sup> )	E (GPa)	$\sigma_f$ (MPa)	Ref.
1D C <sub>f</sub> /ZrB <sub>2</sub> -SiC-Si <sub>3</sub> N <sub>4</sub>	SI + HP (1800-1900°C / 30-40MPa)	< 10	3.70	239 (  ) 188 (⊥)	335 ± 40(  ) 63 ± 7 (⊥)	[38]
2D C <sub>f</sub> /ZrC-SiC	SIP (ZrC+PCS) + HP + PIP PCS (4 cycles/1100°C) + TT (1800°C) + PIP (3 cycles)	6.6	2.47	106 ± 13	178 ± 77	[58]
2D C <sub>f</sub> /ZrC-SiC	PyC interphase (CVI) + SIP (ZrC+PCS) + HP + PIP PCS (4 cycles/1100°C) + TT (1800°C) + PIP (3 cycles)	4.9	2.18	141 ± 12	749 ± 15	[58]
2D C <sub>f</sub> /ZrC-SiC	PyC/SiC interphase (CVI) + SIP (ZrC+PCS) + HP + PIP PCS (4 cycles/1100°C) + TT (1800°C) + PIP (3 cycles)	7.4	2.25	138 ± 15	559 ± 121	[58]
3D C <sub>f</sub> /ZrC-SiC	PyC/SiC interphase (CVI) + PIP ZrC precursor (1600°C) + RMI Si (1500°C)	1.7	2.52	61	380	[59]

#### 4. Realisations and tests in realistic environments

During the development on UHTC monoliths and in particular in ATLLAS projects, we have had the opportunity to assess the materials in diverse facilities to determine their performance. The goal was to test them under conditions that are increasingly representative of a real application. The two most pertinent assessments carried out are exposed below.

##### 4.1. Arc-jet tests

In the first ATLLAS program, a test campaign was carried out under high-enthalpy hypersonic flow in an arc-jet facility of DLR Cologne (L2K) with the support of B. Esser [60]. For each composition sintered by HP (ZS-HP, ZST-HP and HST-HP), four disc-shaped samples (Ø 26.5 mm, e = 4 mm) were investigated between 1100 and 1500°C for cumulated duration up to 900s. Details of the test conditions are provided in Table 8 and an illustration of the test configuration is presented Fig 6. The resistance of the samples to high enthalpy flow was assessed by several measurements and analysis (weighing, thickness checking, SEM observations ...). Weight and thickness variations recorded during these tests are shown in Table 9.

**Table 8.** Test conditions

Parameters	Test Ia	Test Ib	Test II	Test III	Test IV
Duration (s)	300	600	600	600	600
Velocity (m/s)	1821	1821	2038	2251	2432
Total enthalpy (MJ/kg)	2.25	2.25	2.94	3.91	5.14
Expected surface temperature (°C)	1100	1100	1300	1400	1500

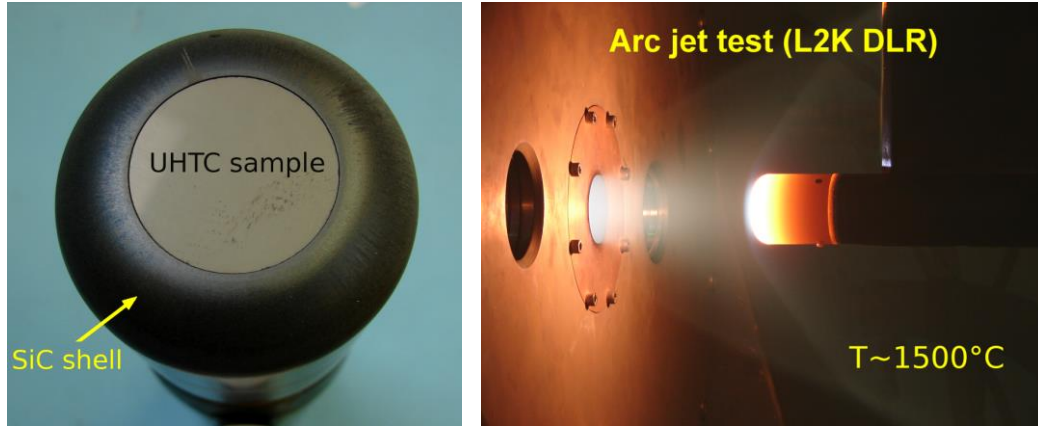

**Fig 6.** Ø 26.5 mm UHTC sample holder and flow field around sample holder during a test at 1500°C

**Table 9.** Variations in weight and thickness for each disc-shaped sample tested

Monolith reference	Sample reference	Status	Weight variation (in g and %)	Thickness variation (µm)
ZS-HP	A	After test Ia :	+ 0.0034 g (0.025%)	none
		After test Ia + Ib :	+ 0.0101 g (0.074%)	none
	B	After test Ia :	+ 0.0035 g (0.026%)	none
		After test Ia + II :	+ 0.0124 g (0.091%)	none
C	After test III :	+ 0.0136 g (0.100%)	none	
D	After test IV :	+ 0.0089 g (0.065%)	none	
ZST-HP	A	After test Ia :	+ 0.0014 g (0.009%)	none
		After test Ia + Ib :	+ 0.0136 g (0.086%)	none
	B	After test Ia :	+ 0.0017 g (0.011%)	none
		After test Ia + II :	+ 0.0089 g (0.056%)	none
C	After test III :	+ 0.0200 g (0.129%)	+ 50 µm	
D	After test IV :	- 0.0511 g (- 0.335%)	+ 50 µm	
HST-HP	A	After test Ia :	+ 0.0015 g (0.006%)	none
		After test Ia + Ib :	+ 0.0104 g (0.042%)	none
	B	After test Ia :	+ 0.0016 g (0.007%)	none
		After test Ia + II :	+ 0.0040 g (0.016%)	none
C	After test III :	+ 0.0112 g (0.046%)	none	
D	After test IV :	+ 0.0073 g (0.030%)	none	

The results of this test campaign were very satisfactory. All the monolithic materials are able to sustain high thermal loads (up to 1500°C/600 s). For each test condition, good material resistance was observed and in particularly extremely low mass and thickness variations as shown in Table 9 ( $\Delta M_{max} = -0.33\%$  and  $\Delta e_{max} = 50 \mu\text{m}$ ). At 1500°C for example, UHTC samples exhibited a two-layered scale made of a thin protective glassy SiO<sub>2</sub> rich layer on the top and underneath an intermediate layer in the process of being oxidised (SiC-depleted layer). Thus, cumulative durations up to 900 s were performed without any problems (for all the selected compositions). A very good sample-to-sample reproducibility and a lack of sensitivity to thermal load cycling have been demonstrated. Furthermore, results are in good agreement with the BLOX4 tests.

As a consequence of the good behaviour obtained in this program, the development of monolithic UHTC has been pushed forward in the ATLLAS II project in order to design, manufacture and test uncooled injectors for ramjet engine.

## 4.2. Uncooled injectors in a ramjet combustor

In the ATLLAS II program, different materials and structures for combustors and advanced hot structures has been studied [4] and notably injectors for ram-based propulsion concepts. The final objective of this work was to validate different concepts in relevant environment (Mach 6 air-breathing flight with stoichiometric combustion) in a MBDA facility (SMR dual-mode ramjet combustion chamber METHYLE) [61]. To begin, a common work has been accomplished by some project partners (DLR, MBDA, ESA and ONERA in particular) in order to define an adequate design for this injector based on a generic rhombus-shaped injection strut with dimensions around 40 mm in length and 20 mm in height. Injectors were required to contain a fuel feed which should exit at two portholes at the strut's downstream region. According to the material nature (CMC or UHTC), the cooling concept used (passive radiation-cooled or active transpiration-cooled) and the leading edge bluntness, several strut injector geometries have been designed in order to assess the material solutions investigated by the DLR and ONERA. Many details about all these different configurations are reported in [48]. For ONERA, in parallel with a development phase dedicated to UHTC monoliths sintered by FAST (ZS-FAST2, HS-FAST2 and HSY-FAST2), the goal was to develop an UHTC uncooled fin injectors in the objective of ensuring a better propulsive efficiency in a future ramjet engine.

The first idea was to manufacture injectors made of two components linked via a sliding connection: an upper part in UHTC directly in the flux (injector) and a lower part in CMC connected to the metallic chamber wall (basis). However, due to difficulties during the machining step on UHTC monoliths, an alternative design has been finally selected. This hybrid design was less difficult to realise. It was also made of two components: a leading edge of 1 mm radius in UHTC placed in front of the flux and a basis in CMC for the lower part and also for the rear upper part of the injector. A Carbon fibre reinforced silicon carbide composite (C/C-SiC) provided and machined by the DLR (Stuttgart) has been selected for this purpose. We can notice than a specific design of the bottom of the CMC has also been done by the DLR to perfectly connect the assembly to the METHYLE test bench.

The most important advantage of this hybrid design was to avoid the passage of the fuel injection tube in two different materials, which would imply a perfect control of the tightness between the CMC and the UHTC parts. Some schematic representations of this concept are presented in Fig 7.

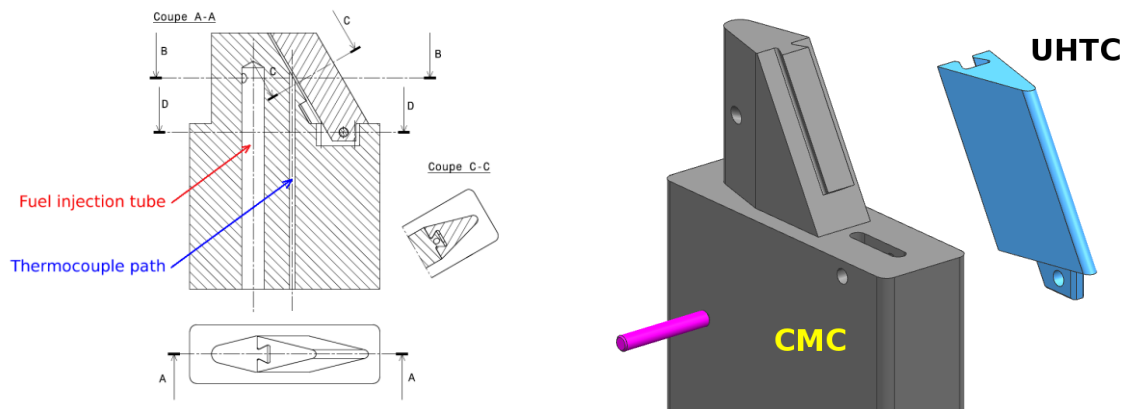

**Fig 7.** Schematic representations of the hybrid design selected for the UHTC uncooled fin injector

According to the previous design, two types of hybrid injectors have been manufactured for the test phase: one with an UHTC leading edge made from a HS-FAST2 monolith and another one machined from a HSY-FAST2 monolith. CMC basis of same nature were used for both types of injectors. As planned, the test campaign has been performed with the MBDA facility to simulate a long duration flight at Mach 6 (Fig 8). During this campaign, hybrid injectors presented in this paragraph but also, as mentioned previously, other injector concepts based on CMC were investigated [48]. The fuel injected through the assembly was a gaseous mixture of  $H_2$  and  $CH_4$  (20/80%) with an equivalence ratio of 1.0. This corresponded to a mass flow of 12 g/s for each strut injector. The incoming air had a recovery temperature of about 1330°C, and no cooling by radiation was possible thanks to a thermal barrier coating on the walls. Moreover, it is interesting to specify that the test campaign was carried out with a rather brutal combustion cycle generating important thermal shocks during ignition but also during extinction (high nitrogen mass flow cooling).

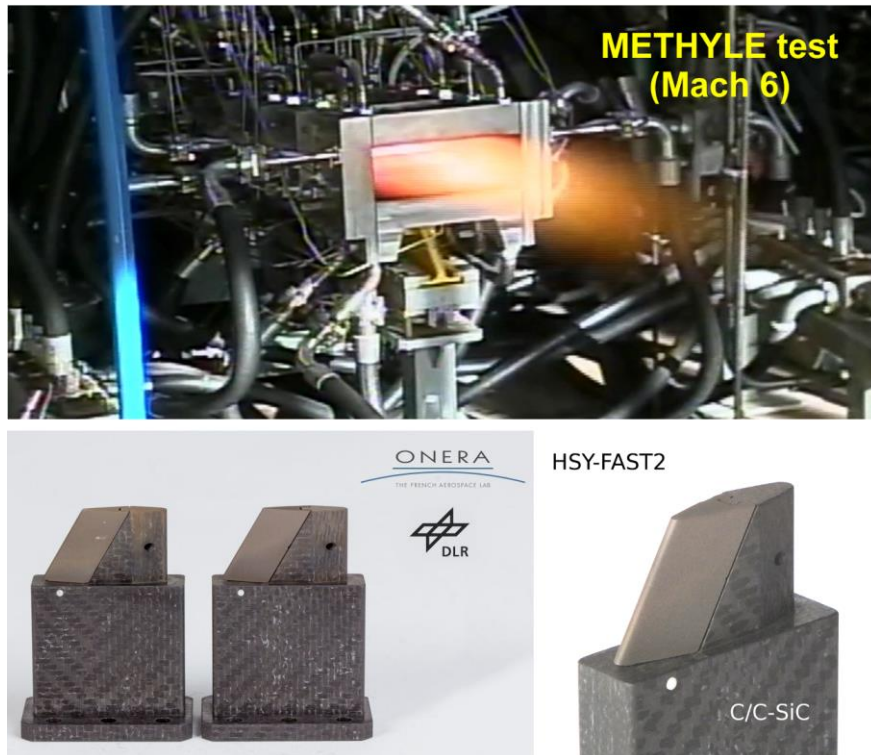

**Fig 8.** METHYLE facility during test at Mach 6 and aspect of the hybrid injectors after the test campaign

As we can see on the pictures of the Fig 8 but also by analysing others parameters observed during the test (surface temperature at the rear part of the UHTC leading edge in particular), the results are very promising. There are just some traces of the flux on the external surfaces of the injectors. So, despite the fact that an assessment of monolithic UHTCs in realistic combustion environment was really challenging, excellent results have been obtained. Thus, the capabilities of thin uncooled UHTC injectors ( $R = 1 \text{ mm}$ ) to sustain a severe and long test in combustion environment has been demonstrated. For information promising results have also been obtained on transpiration-cooled CMC injectors based on permeable C/C-SiC material [4,48].

Therefore, thanks to a fruitful collaborative work achieved notably with DLR and MBDA, hybrid injectors made of UHTC and CMC have been successfully tested in relevant conditions. This success is particularly promising and it paves the way for new realisations (optimised uncooled injectors, fins, rudders, nozzles ...).

## 5. Conclusions and perspectives

Hypersonic and propulsion applications provide some unique thermal-structural challenges (sharp leading edges, air intakes, uncooled injectors, etc.). In order to fulfil the requirements of these components, some specific materials seem to be compulsory: UHTCs. Indeed, thanks to their unique combination of mechanical, thermal and chemical properties, UHTCs are a promising technology for use in a number of high temperature structural applications.

In this context, for more than a decade, Onera has been involved in several studies. Most of the work has been focused on monolithic ceramics and further programs are still engaged on this way. Indeed, thanks to a new high capacity sintering facility received in 2018 (DCS 200-40 from Thermal Technology LLC), several projects to increase UHTC monolithic properties and their potential uses are under progress. Moreover, the demonstration of their ability to fulfil the requirements of ramjet combustor environment is a base to build new projects for more efficient propulsion components.

However, for some structural applications, their toughness performance is not sufficient. That is why a good part of the work recently achieved has been focalised on the development of UHTCMC by a slurry infiltration process. First results are encouraging but some improvements are still necessary to optimise their densification (several infiltrations, new infiltrations parameters, finer powder grain size, new raw materials ...) and their

mechanical behaviour (adequate fibre/matrix interphase). Indeed, these are the solutions to increase their global performance (oxidation resistance and mechanical strength notably).



## References

1. Glass, D.E.: Ceramic Matrix Composite (CMC) Thermal Protection Systems (TPS) and Hot Structures for Hypersonic Vehicles. 15<sup>th</sup> AIAA International Space Planes and Hypersonic Systems and Technologies Conference, Dayton, Ohio, USA, doi:10.2514/6.2008-2682 (2008).
2. Fay, J.A., Riddell, F.R.: Theory of Stagnation Point Heat Transfer in Dissociated Air. *J. Aeron. Sci.* 25 (2), 73-85 (1958).
3. Van Wie, D.M., Drewry Jr, D.G., King, D.E., Hudson, C.M.: The hypersonic environment: required operating conditions and design challenges. *J. Mater. Sci.* 39, 5915-5924 (2004).
4. Steelant, J., Dalenbring, M., Kuhn, M., Bouchez, M., Von Wolfersdorf, J.: Achievements obtained within ATLLAS-II on Aero-Thermal Loaded Material Investigations for High-Speed Vehicles. 21<sup>th</sup> AIAA International Space Planes and Hypersonic Systems and Technologies Conference, Xiamen, China, doi:10.2514/6.2017-2393 (2017).
5. Monteverde, F., Bellosi, A., Scatteia, L.: Processing and properties of ultra-high temperature ceramics for space applications. *Mater. Sci. Eng. A* 485, 415-421 (2008).
6. Squire, T.H., Marschall, J.: Material Property Requirements for Analysis and Design of UHTC Components in Hypersonic Applications. *J. Eur. Ceram. Soc.* 30 [11], 2239-2251 (2010).
7. Opeka, M.M., Talmy, I.G., Zaykoski, J.A.: Oxidation-Based Materials Selection for 2000°C + Hypersonic Aerosurfaces: Theoretical Considerations and Historical Experience. *J. Mater. Sci.* 39, 5887-5904 (2004).
8. Paul, A., Jayaseelan, D.D., Venugopal, S., Zapata-Solvas, E., Binner, J., Vaidhyanathan, B., Heaton, A., Brown, P., Lee, W.E.: UHTC composites for hypersonic applications. *Am. Ceram. Soc. Bul.* 91, 22-29 (2012).
9. Fahrenholtz, W.G., Wuchina, E.J., Lee, W.E., Zhou, Y.: *Ultra-High Temperature Ceramics: Materials for Extreme Environment Applications*. Wiley-American Ceramic Society (2014).
10. Justin, J.F., Jankowiak, A.: *Ultra High Temperature Ceramics: Densification, Properties and Thermal Stability*. AerospaceLab, Issue 3: High Temperature Materials (2011).
11. Levine, S.R., Opila, E.J., Halbig, M.C., Kiser, J.D., Singh, M., Salem, J.A.: Evaluation of Ultra-High temperature Ceramics for Aeropropulsion Use. *J. Eur. Ceram. Soc.* 22, 2757-2767 (2002)
12. Han, J., Zhang, X., Meng, S.: Oxidation behaviour of zirconium diboride-silicon carbide at 1800°C. *Scripta Materialia* 57, 825-828 (2007)
13. Fahrenholtz, W.G.: Thermodynamic Analysis of ZrB<sub>2</sub>-SiC Oxidation: Formation of a SiC-Depleted Region. *J. Am. Ceram. Soc.* 90, 43-148 (2007)
14. Monteverde, F., Bellosi, A.: Oxidation of ZrB<sub>2</sub>-Based Ceramics in Dry Air. *J. Electrochemical Society* 150 [11], B552-B559 (2003)
15. Guo, S.Q.: Densification of ZrB<sub>2</sub>-based composites and their mechanical and physical properties: a review. *J. Eur. Ceram. Soc.* 29, 995-1011 (2009).
16. Bellosi, A., Monteverde, F., Sciti, D.: Fast Densification of Ultra-High-Temperature Ceramics by Spark Plasma Sintering. *Int. J. Appl. Ceram. Technol.*, 3 [1], 32-40 (2006)
17. Savino, R., De Stefano Fumo, M., Silvestroni, L., Sciti, D.: Arc-jet testing on HfB<sub>2</sub> and HfC-based ultra-high temperature ceramic materials. *J. Eur. Ceram. Soc.* 28, 1899-1907 (2008)
18. Gasch, M., Johnson, S., Marschall, J.: Thermal conductivity characterization of hafnium diboride-based ultra-high-temperature ceramics. *J. Am. Ceram. Soc.* 91, 1423-1432 (2008)
19. Hu, C., Sakka, Y., Tanaka, H., Nishimura, T., Guo, S., Grasso, S.: Microstructure and properties of ZrB<sub>2</sub>-SiC composites prepared by spark plasma sintering using TaSi<sub>2</sub> as sintering additive. *J. Eur. Ceram. Soc.* 30, 2625-2631 (2010)
20. Zhang, S., Wang, S., Zhu, Y., Chen, Z.: Fabrication of ZrB<sub>2</sub>-ZrC-based composites by reactive melt infiltration at relative low temperature. *Scr. Mater.* 65, 139-142 (2011).
21. Silvestroni, L., Bellosi, A., Melandri, C., Sciti, D., Liu, J.X., Zhang, G.J.: Microstructure and properties of HfC and TaC-based ceramics obtained by ultrafine powder. *J. Eur. Ceram. Soc.* 31, 619-627 (2011)
22. Liu, H.T., Zhang, G.J.: Reactive synthesis of ZrB<sub>2</sub>-based ultra high temperature ceramics. *J. Korean Cer. Soc.* 49, 308-317 (2012)
23. Zamora, V., Ortiz, A.L., Guiberteau, F., Nygren, M.: Spark-plasma sintering of ZrB<sub>2</sub> ultra-high-temperature ceramics at lower temperature via nanoscale crystal refinement. *J. Eur. Ceram. Soc.* 32, 2529-2536 (2012)
24. Johnson, S.M.: Ultra-High Temperature Ceramics UHTCs. Oral presentation, Proceedings of the Thermal Protection System Technical Interchange Meeting (TPS TIM), pp. 1-65, Moffett Field, California, USA <https://ntrs.nasa.gov/archive/nasa/casi.ntrs.nasa.gov/20150022996.pdf> (2015)
25. Silvestroni, L., Stricker, K., Sciti, D., Kleebe, H.J.: Understanding the oxidation behavior of a ZrB<sub>2</sub>-MoSi<sub>2</sub> composite at ultra-high temperatures. *Acta Materialia* 151, 216-228 (2018)

26. Silvestroni, L., Sciti, D., Melandri, C., Guicciardi, S.: Toughened ZrB<sub>2</sub>-based ceramics through SiC whisker or SiC chopped fiber additions. *J. Eur. Ceram. Soc.* 30, 2155-2164 (2010)
27. Musa, C., Orrù, R., Sciti, D., Silvestroni, L., Cao, G.: Synthesis, consolidation and characterization of monolithic and SiC whiskers reinforced HfB<sub>2</sub> ceramics. *J. Eur. Ceram. Soc.* 33, 603-614 (2013)
28. Lahiri, D., Khaleghi, E., Bakshi, S.R., Li, W., Olevsky, E.A., Agarwal, A.: Graphene-induced strengthening in spark plasma sintered tantalum carbide-nanotube composite. *Scripta Mater.* 68, 285-288 (2013)
29. Li, L., Wang, Y., Cheng, L., Zhang, L.: Preparation and properties of 2D C/SiC-ZrB<sub>2</sub>-TaC composites. *Ceram. Int.* 37, 891-896 (2011).
30. Paul, A., Venugopal, S., Binner, J., Vaidhyanathan, B., Heaton, A.C.J., Brown, P.M.: UHTC-Carbon Fibre Composites: Preparation, Oxyacetylene Torch Testing and Characterisation. *J. Eur. Ceram. Soc.* 33, 423-432 (2013).
31. Silvestroni, L., Dalle Fabbriche, D., Sciti, D.: Tyranno SA3 fiber-ZrB<sub>2</sub> composites. Part I: Microstructure and densification. *Mater. Des.* 65, 1253-1263 (2015).
32. Küttemeyer, M., Schomer, L., Helmreich, T., Rosiwal, S., Koch, D.: Fabrication of ultra high temperature ceramic matrix composites using a reactive melt infiltration process. *J. Eur. Ceram. Soc.* 36, 3647-3655 (2016).
33. Tang, S., Hu, C.: Design, Preparation and Properties of Carbon Fiber Reinforced Ultra-High Temperature Ceramic Composites for Aerospace Applications: A Review. *J. Mater. Sci. Technol.* 33, 117-130 (2017).
34. Li, Q., Dong, S., Wang, Z., Shi, G.: Fabrication and properties of 3-D Cf/ZrB<sub>2</sub>-ZrC-SiC composites via polymer infiltration and pyrolysis. *Ceram. Int.* 39, 5937-5941 (2013).
35. Zhang, M., Li, K., Shi, X., Tan, W.: Effects of SiC interphase on the mechanical and ablation properties of C/C-ZrC-ZrB<sub>2</sub>-SiC composites prepared by precursor infiltration and pyrolysis. *Mater & Des.* 122, 322-329 (2017)
36. Küttemeyer, M., L., Helmreich, T., Rosiwal, S., Koch, D.: Influence of zirconium-based alloys on manufacturing and mechanical properties of ultra high temperature ceramic matrix composites. *Advances in Applied Ceramics* 117, s62-s69 (2018).
37. Ni D-W, Wang J-X, Dong S-M, Chen X-W, Kan Y-M, Zhou H-J, Gao L., Zhang X-Y : Fabrication and properties of C<sub>f</sub>/ZrC-SiC-based composites by an improved reactive melt infiltration. *J. Am. Ceram. Soc.* 101(8), 3253-3258 (2018)
38. Zoli, L., Vinci, A., Galizia, P., Melandri, C., Sciti, D.: On the thermal shock resistance and mechanical properties of novel unidirectional UHTCMCs for extreme environments. *Scientific Reports.* 8 (9148), 1-9 (2018).
39. Rubio, V., Binner, J., Cousinet, S., Le Page, G., Ackerman, T., Hussain, A., Brown, P., Dautremont, I.: Materials characterisation and mechanical properties of C<sub>f</sub>-UHTC powder composites. *J. Eur. Ceram. Soc.* 39 (4), 813-824 (2019)
40. Sciti, D., Silvestroni, L., Monteverde, F., Vinci, A., Zoli, L.: Introduction to H2020 EU project C<sup>3</sup>HARME: Next generation ceramic composites for combustion harsh environments and space. Conference on Ultra-High Temperature Ceramics: Materials for Extreme Environment Applications IV, Windsor, UK (2017)
41. Steelant, J.: Hypersonic Technology Developments with EU Co-Funded Projects. RTO/AVT/VKI Lecture Series on high speed propulsion : engine design - integration and thermal management edition RTO-EN-AVT-185, Rhode-St-Genèse, Belgium (2007).
42. Steelant, J.: ATLLAS: Aero-Thermal Loaded Material Investigations for High-Speed Vehicles. 15<sup>th</sup> AIAA International Space Planes and Hypersonic Systems and Technologies Conference, Dayton, Ohio, USA, doi:10.2514/6.2008-2582 (2008).
43. Steelant, J.: Key Technologies for Hypersonic Sustained Flight Assessed within LAPCAT and ATLLAS Projects. The 6<sup>th</sup> European Symposium on Aerothermodynamics for Space Vehicles, Versailles, France (2008).
44. Steelant, J.: Achievements obtained on Aero-Thermal Loaded Materials for High-Speed Atmospheric Vehicles within ATLLAS. 16<sup>th</sup> AIAA International Space Planes and Hypersonic Systems and Technologies Conference, Bremen, Germany, doi:10.2514/6.2009-7225 (2009).
45. Justin, J.F.: Investigations of High Temperature Ceramics for Sharp Leading Edges or Air Intakes of Hypersonic Vehicles, European Conference of Aerospace Sciences, Versailles, France (2009).
46. Bouchez, M., Crampon, F., Le Naour, B., Wilhelmi, C., Bubenheim, K., Kuhn, M., Mainzer, B., Riccius, J., Davoine, C., Justin, J.F., Von Wolfersdorf, J., Abdelmoula, M., Villace, V.F., Steelant, J.: Combustor and Material Integration for High Speed Aircraft in the European Research Program ATLLAS 2. 19<sup>th</sup> AIAA International Space Planes and Hypersonic Systems and Technologies Conference, Atlanta, Georgia, USA, doi:10.2514/6.2014-2950 (2014).

47. Bouchez, M., Dufour, E., Le Naour, B., Wilhelmi, C., Bubenheim, K., Kuhn, M., Mainzer, B., Riccius, J., Davoine, C., Justin, J.F., Axtmann, M., Von Wolfersdorf, J., Spring, S., Villace, V.F., Steelant, J.: Combustor Materials Research Studies for High Speed Aircraft in the European Program ATLLAS-II. 20<sup>th</sup> AIAA International Space Planes and Hypersonic Systems and Technologies Conference, Glasgow, Scotland, doi:10.2514/6.2015-3639 (2015).
48. Kuhn, M., Bouchez, M., Le Naour, B., Justin, J.F., Van den Eyde, J., Steelant, J.: Ceramic Strut Injection Technologies for High-Speed Flight. 21<sup>st</sup> AIAA International Space Planes and Hypersonic Systems and Technologies Conference, Xiamen, China, doi:10.2514/6.2017-2416 (2016).
49. Guérineau, V.: Mécanismes et cinétiques d'oxydation de matériaux ultraréfractaires sous conditions extrêmes. Ph.D. Dissertation of Pierre et Marie Curie University (2017).
50. Guérineau, V., Julian-Jankowiak, A.: Oxidation mechanisms under water vapour conditions of ZrB<sub>2</sub>-SiC and HfB<sub>2</sub>-SiC based materials up to 2400°C. *J. Eur. Ceram. Soc.* 38, 421-432 (2018).
51. Sévin, L., Julian-Jankowiak, A., Justin, J.F., Langlade, C., Bertrand, P., Pelletier, N.: Structural Stability of Hafnia-Based Materials at Ultra-High Temperature. *Materials Science Forum* 941, 1972-1977, <https://doi.org/10.4028/www.scientific.net/msf.941.1972> (2018)
52. ASTM Standard E1876-09 – Standard Test Method for Dynamic Young's Modulus, Shear Modulus, and Poisson's Ratio by Impulse Excitation of Vibration.
53. Anstis, G.R., Chantikul, P., Lawn, B.R., Marshall, D.B.: A Critical Evaluation of Indentation Techniques for Measuring Fracture Toughness: I . Direct Crack Measurements, *J. Am. Ceram. Soc.* 64, 534-553 (1981).
54. Monteverde, F.: Ultra-high temperature HfB<sub>2</sub>-SiC ceramics consolidated by hot-pressing and spark plasma sintering. *Journal of Alloys and Compounds* 428, 197-205 (2007)
55. Sciti, D., Bonnefont, G., Fantozzi, G., Silvestroni, L.: Spark plasma sintering of HfB<sub>2</sub> with low additions of silicides of molybdenum and tantalum. *J. Eur. Ceram. Soc.* 30, 3253-3258 (2010)
56. Watts, J., Hilmas, G., Fahrenholtz, W.G.: Mechanical Characterization of ZrB<sub>2</sub>-SiC Composites with Varying SiC Particle Sizes. *J. Am. Ceram. Soc.* 94 [12], 4410-4418 (2011)
57. Zapata-Solvas, E., Jayaseelan, D.D., Lin, H.T., Brown, P., Lee, W.E.: Mechanical properties of ZrB<sub>2</sub>- and HfB<sub>2</sub>-based ultra-high temperature ceramics fabricated by spark plasma sintering. *J. Eur. Ceram. Soc.* 33, 1373-1386 (2013).
58. Wang, Z., Dong, S., Zhang, X., Zhou, H. et al : Fabrication and Properties of C<sub>f</sub>/SiC-ZrC Composites. *J. Am. Ceram. Soc.* 91 [10], 3434-3436 (2008)
59. Ni, D.W., Wang, J.X., Dong, S.M., Chen, X.W. et al : Fabrication and properties of Cf/ZrC-SiC-based composites by an improved reactive melt infiltration. *J. Am. Ceram. Soc.* 101 [8], 3253-3258 (2018)
60. Gülhan, A., Esser, B.: Arc-Heated Facilities as a Tool to Study Aerothermodynamic Problems of Reentry Vehicles. *Progress in Astronautics and Aeronautics*, Vol. 198, AIAA, 375-403 (2002).
61. Minard, J.P., Falempin, F.: METHYLE - A New Long Endurance Test Facility for Dual-Mode Ramjet Combustor Technologies. 15<sup>th</sup> AIAA International Space Planes and Hypersonic Systems and Technologies Conference, Dayton, Ohio, USA, doi:10.2514/6.2008-2650 (2008).