



HAL
open science

A Humanoid Torso For Palletization in Logistics Warehouses

Khairidine Benali, Jean-François Brethé, François Guerin, Marc Gorka, Ali Sayah

► **To cite this version:**

Khairidine Benali, Jean-François Brethé, François Guerin, Marc Gorka, Ali Sayah. A Humanoid Torso For Palletization in Logistics Warehouses. 12th International Doctoral Student Workshop on Logistics, Jun 2019, Magdeburg, Germany. <hal-02757152v2>

HAL Id: hal-02757152

<https://hal.science/hal-02757152v2>

Submitted on 16 Apr 2023

HAL is a multi-disciplinary open access archive for the deposit and dissemination of scientific research documents, whether they are published or not. The documents may come from teaching and research institutions in France or abroad, or from public or private research centers.

L'archive ouverte pluridisciplinaire **HAL**, est destinée au dépôt et à la diffusion de documents scientifiques de niveau recherche, publiés ou non, émanant des établissements d'enseignement et de recherche français ou étrangers, des laboratoires publics ou privés.



HAL Authorization

A HUMANOID TORSO FOR PALLETIZATION IN LOGISTICS WAREHOUSES

Khairidine Benali, Jean-François Brethé, François Guérin, Marc Gorka, Ali Sayah
Research Group in Electrotechnics and Automatics (GREAH)
University of Le Havre, France

1 Abstract

This paper presents a new motion controller for object manipulation in 6D-space with a dual-arm robot manipulator. Current industrial systems often consist of a single robot arm commanded through a teach pendant. These systems are unable to pick and place boxes with different dimensions because in most of the pick and place applications, the robot arm is using a specific end-effector (generally an electric or pneumatic gripper) to pick the object. Hence the variety of objects is highly limited. This is the reason why the gripper manufacturers offer a wide variety of grippers to cover a wide range of applications. In the specific context of warehouse, the robot has to deal with a large variety of object, and has for instance to grasp boxes of different dimensions. It is then difficult to use robots in a similar manner as before. We proposed in this project to introduce a dual-arm manipulator, settled on a humanoid torso to grasp boxes of different dimensions by applying a contact on the lateral faces of the boxes and control the contact forces. Our work involves a dual-arm humanoid robot with two Universal Robots (UR10) arms and a torso (CROM) for manipulating big and/or heavy objects. The motion controller has been designed for coordinated manipulation according to the desired trajectory of the object. To prevent the objects from drifting and falling, an hybrid force-motion controller is implemented using sensors located at the end-effectors. The different components (arms, torso, camera, force sensors...) of the system are controlled using ROS, which is an open-source meta-operating system distributed for research and development in robotics.

2 Introduction

Industrial robots have been used in manufacturing lines for many years for their simplicity of programming through a teach pendant by giving a set of points for following a trajectory in order to achieve repetitive tasks. But in most of the pick and place applications, the robot arm is using a specific end-effector (generally an electric or

pneumatic gripper) to pick the object. Hence the variety of objects is highly limited. This is the reason why the gripper manufacturers offer a wide variety of grippers to cover a wide range of applications. In the specific context of warehouse, the robot has to deal with a large variety of object, and has for instance to grasp boxes of different dimensions. It is then difficult to use robots in a similar manner as before. We proposed in this project to introduce a dual-arm manipulator, settled on a humanoid torso to grasp boxes of different dimensions by applying a contact on the lateral faces of the boxes and control the contact forces. Some works have already been done in the field with successful results. The authors in [1] proposed a Force-Impedance control by switching between two behaviors. The first is a limited impedance control and the second one is a position limited force control. The control is based on two cascaded controllers: a standard impedance controller, as an internal loop controller and an integral force controller used as an external loop controller. The simulation of the proposed controllers, provides a good tracking in position, impedance and force.

Some other research works also focus in control of dual arms in the context of sliding mode control [2], [3], which involves the control in presence of the dynamic parameters of the robots and the objects. The main idea presented is a sliding mode controller which is implemented for the trajectory tracking by taking into account the internal forces. A study of the dynamics of dual arms working together to move an object is also derived to design the sliding mode controller and then compute the control law. The problem of chattering in the controller is solved by replacing the switching sliding mode with a continuous saturation function. A robust control strategy is proposed by the authors in [4] for a planar dual arm manipulator robot. It is based on a dynamic study of the object and on the grasping constraints (desired force, contact and friction conditions) considered to move an object by a multiple arm cooperative manipulator. They have proposed some conditions to be satisfied for no slippage by friction constraints and contact. An

algorithm is applied for the optimization of the energy consumed by the arms subjected to two cases of equality and inequality constraints of grasping. The proposed controller was a switching sliding algorithm. For eliminating the phenomenon of chattering, it is replaced by a saturation function.

Other works concentrate on impedance control. It is based on the internal force of dual arm for coordinated manipulation objects. These works propose a robust control law for dual arm manipulators by computing the minimum desired internal force by using a data force sensor. It also introduces the frictional constraints for computing the Cartesian-space impedance control for each manipulator. The stability of the control was studied to validate the frictional constraints. The experiment was executed with two PUMA arms manipulating a rigid object and the results, show a robust control of pose in grasping object [5].

In [6] the authors describe a dual arm control for complex operations. In this work a singular perturbation analysis was done and they design an architecture of control using a separate Cartesian impedance control for dual arm. The experiment consisted in grasping a flat object from a table with grasping points hence to prove the robustness of the controller. The authors in [7] developed a strategy of a centralized impedance control to implement a compliant behavior to the object grasping by the dual arms. They use the compliance in three levels i.e. the object, the end-effector and the body. A dynamic modeling of manipulators along with the object is done. Internal and external null space impedance control is proposed in series, to impose an impedance behavior between object/environment, end effectors/object interaction and body/environment interactions. The control loop is verified through simulations using two 7-DOF KUKA robots. The approach developed in [8] presents simultaneous control of trajectory and interaction forces in dual arm configurations. A system composed of two planar robots and an object realising a closed chain kinematics is presented and the dynamic equation of motion is computed by the Lagrange multipliers. A non linear feedback control is proposed by applying a systematic nonlinear feedback technique to motion equations of the closed chain. A simulation of the model has been presented for indicating the advantages of this controller.

More recently a hybrid position/force controller is used by the authors in [9], [12] to achieve the coordination of dual arm manipulation through a master/slave action by controlling the force in each direction for the manipulation of flexible materials. The strategy of control is developed by studying the bending of a flexible beam, consisting of providing a motion along a certain direction. The other directions are controlled in

force. The control loop used, consists in computing the position whereas the force controllers are translated to joint space velocities via the Jacobian pseudoinverse. Another work presents a control strategy for simultaneously inserting multiple boxes in a master box using dual arms. The controller uses the forces applied by the arms and is based on the virtual spring damper hypothesis. The task planning is inspired from human beings meaning, to make contact with each end of the box and press them together with a suitable force to be able to grasp the multiple boxes [10]. The industrial robots are able to do repetitive tasks without any kind of interaction. A sensor based dual arm is a novel system used for general tasks with bimanual hybrid motion/force control. The operator can use hand motion gestures to achieve a desired position of the object and a 3D camera can track the movements in real time and at the same time the force control tries to maintain the grasping. The whole control in this work consists of a software ROBOT RACONTEUR using a 15 DOF Yaskawa Motoman with a kinect 3D camera and force /torque sensors for the feedback [11].

The main goal of our work is to study and develop an industrial robust system able to manipulate big and/or heavy loads by coordinated manipulations and respect of the force applied by both arms. In this paper we present a new controller for dual industrial arms for grasping and manipulation of a rigid object. The control strategy was developed (hybrid force/position controller) on the ROS middleware. Compared to the related works, our goal consists in making the cardboardbox move according to a desired trajectory and to derive from that the motion of each arm. Our work consists in motion control of dual arms for palletizing/depalletizing tasks in the logistics industry, when the parcels have different sizes. In this industry there is a need to manipulate products with a large variability in size, weight and texture.

3 Dual arm system description

The platform used is shown on figure 1.

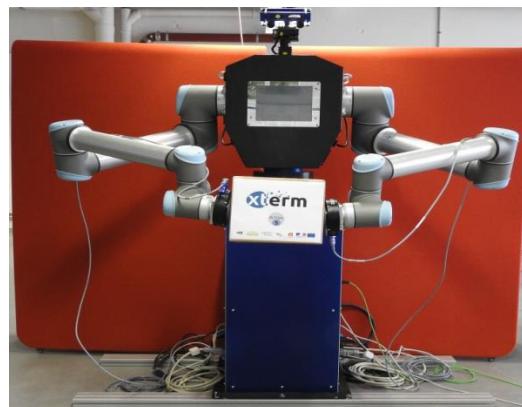

Figure 1: The CROM robot with dual UR10

It is a semi humanoid dual arm robot consisting of two universal robot arms UR10 each with 6-DOF and a torso CROM with 1-DOF. The CROM is composed of a head equipped with a camera XTION 3D actuated by two dynamixel pro H42 for the pan tilt movements. The end of each arm is equipped with a Robotiq force/torque Sensor FT 150.

The components of our system are coordinated by ROS (Robot Operating System) that provides interprocess message passing services (IPC) in a network.

4 Modeling of the Robot

The simplified kinematic model of the UR10 arm is shown on figure 2.

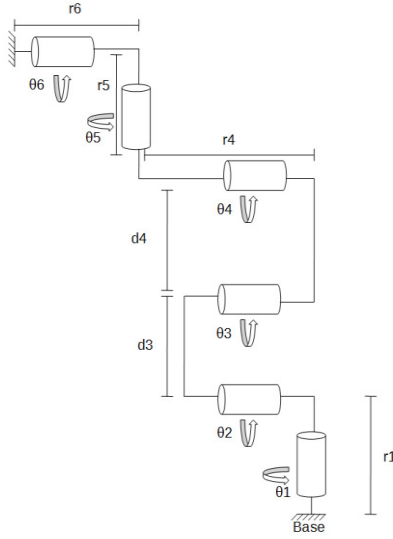

Figure 2: Kinematic model of UR10 arm

In order to adjust the robot's controller, a kinematic modeling is done by the Denavit Hartenberg (DH) method for its simplicity and capability to modeling any kind of serial manipulator. The system at hand consists of three branches including one torso and two arms (we denoted the arms as arm left and arm right). Each arm branch has six DOF (3 for the desired position and 3 for the orientation of the end effector). Each arm is modeled by using the DH convention.

Joint	$a_i(\text{rad})$	$d_i(\text{m})$	$r_i(\text{m})$	$\theta_i(\text{rad})$
1	0	0	0.1280	θ_1
2	$\frac{\pi}{2}$	0	0	θ_2
3	0	-0.6127	0	θ_3
4	0	-0.5716	0.1639	θ_4
5	$\frac{\pi}{2}$	0	0.1157	θ_5
6	$-\frac{\pi}{2}$	0	0.0922	θ_6

Figure 3: Denavit-Hartenberg (DH) parameter

A homogeneous transformation for each link has been calculated by computing the overall matrix and by multiplying the individual transformations matrix from the origin to the goal point.

$$T_{01} = \begin{bmatrix} \cos(\theta_1) & -\sin(\theta_1) & 0 & 0 \\ \sin(\theta_1) & \cos(\theta_1) & 0 & 0 \\ 0 & 0 & 1 & r_1 \\ 0 & 0 & 0 & 1 \end{bmatrix} \quad T_{12} = \begin{bmatrix} \cos(\theta_2) & -\sin(\theta_2) & 0 & 0 \\ 0 & 0 & -1 & 0 \\ \sin(\theta_2) & \cos(\theta_2) & 0 & 0 \\ 0 & 0 & 0 & 1 \end{bmatrix}$$

$$T_{23} = \begin{bmatrix} \cos(\theta_3) & -\sin(\theta_3) & 0 & d_3 \\ \sin(\theta_3) & \cos(\theta_3) & 0 & 0 \\ 0 & 0 & 1 & 0 \\ 0 & 0 & 0 & 1 \end{bmatrix} \quad T_{34} = \begin{bmatrix} \cos(\theta_4) & -\sin(\theta_4) & 0 & d_4 \\ \sin(\theta_4) & \cos(\theta_4) & 0 & 0 \\ 0 & 0 & 1 & r_4 \\ 0 & 0 & 0 & 1 \end{bmatrix}$$

$$T_{45} = \begin{bmatrix} \cos(\theta_5) & -\sin(\theta_5) & 0 & 0 \\ 0 & 0 & -1 & r_5 \\ \sin(\theta_5) & \cos(\theta_5) & 0 & 0 \\ 0 & 0 & 0 & 1 \end{bmatrix} \quad T_{56} = \begin{bmatrix} \cos(\theta_6) & -\sin(\theta_6) & 0 & 0 \\ 0 & 0 & 1 & r_6 \\ \sin(\theta_6) & \cos(\theta_6) & 0 & 0 \\ 0 & 0 & 0 & 1 \end{bmatrix}$$

We can compute the transformation between the base frame and the effector frames with the following equations:

$$T_{06} = T_{01} T_{12} T_{23} T_{34} T_{45} T_{56} \quad (1)$$

Let us consider the grasping problem by a dual arm. For studying the transformation between the base frame of the robot and the object grasped we consider that a closed kinematic chain is formed by the torso CROM and the dual UR10 arms. Considering the forward kinematic model of each arm is known, we can locate the object in the base frame by the geometric relationship.

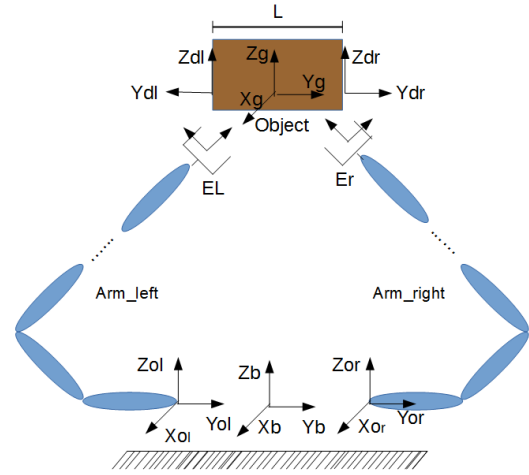

Figure 4: Closed kinematic chain

The kinematic equation is computed by considering the left and the right arms:

$${}^b T_g = {}^b T_{ol} \cdot {}^{ol} T_{El} \cdot {}^{El} T_g$$

$${}^b T_g = {}^b T_{or} \cdot {}^{or} T_{Er} \cdot {}^{Er} T_g \quad (2)$$

We assume that the center of gravity (Xg;Yg;Zg) located at the center of the cardboard box. The coordinates of the other component of the system are defined such as shown on figure 4.

$[X_b, Y_b, Z_b]$: Torso frame.
 $[X_l, Y_l, Z_l]$: Left arm end effector frame.
 $[X_r, Y_r, Z_r]$: Right arm end effector frame.
 $[X_g, Y_g, Z_g]$: Object frame.
 $[X_{ol}, Y_{ol}, Z_{ol}]$: Base frame of the left arm (fixed to the body of the torso).
 $[X_{or}, Y_{or}, Z_{or}]$: Base frame of the right arm (fixed to the body of the torso).

${}^bT_{ol}$ and ${}^bT_{or}$ are dependent on the installation of the system i.e they are constant relative to the geometry of the torso.

5 Task space control

The task space control [13] provides the ability to control the end effector in 6D space by controlling the positions and the orientation of the end effector by minimizing or eliminating the position and orientation error. UR10 is a 6-DOF serial link manipulator, provided with an internal low level dynamic controller which is able to compensate the gravity and the non-linearities. This controller cannot be modified to the access constraints. However the input of many industrial robots such as UR10, is a vector of 6 joints angles calculated through a trajectory generator (such as the ROS package Moveit).

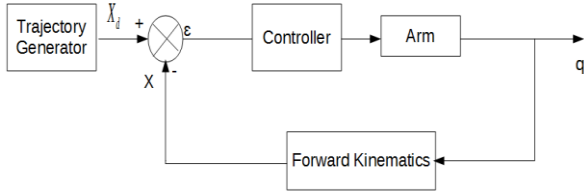

Figure 5: Diagram of the task space control

With X_d is the desired position and X the actual position. The angular \dot{q} and linear velocities ϑ are related to the joint velocities by:

$$\begin{aligned} \vartheta_l &= J_l(q) \dot{q}_l \\ \vartheta_r &= J_r(q) \dot{q}_r \end{aligned} \quad (3)$$

q_l and q_r are the joints angles vector of the left arm and right arm respectively, $J(q)$ is the Jacobian matrix. ϑ_l and ϑ_r contain the linear and angular velocities of the left and right end effectors.

$$\vartheta_l = \begin{bmatrix} V_l \\ \omega_l \end{bmatrix} \quad \vartheta_r = \begin{bmatrix} V_r \\ \omega_r \end{bmatrix} \quad (4)$$

The joint velocities are computed by solving the differential equation for \dot{q} at measured joint angles and the joint positions $q(t)$ can then be obtained by integration the velocity solution over time.

Given the desired position and orientation of the end effector (p_d, R_d) and the actual pose (p, R), let us denote the position and orientation error by:

$$e_p = p_d - p \quad \text{and} \quad e_r = \phi(R_d R^T)$$

We define ϕ as a quaternion vector to represent the orientation.

The relationship between the angular velocity and the quaternion velocity can be expressed by:

$$\dot{\phi} = [J_v(\phi)] \omega \quad (5)$$

J_v is the Jacobian related the angular velocity to the quaternion velocity.

We can adjust the Jacobian to change from joint velocity to quaternion velocity:

$$\dot{\phi} = J_v(\dot{\phi}_d) J_\omega(q) \dot{q} = J_{v\omega}(\dot{\phi}_d, q) \dot{q} \quad (6)$$

J_ω is the Jacobian associated with the end effector angular velocity.

The task space controller will then map the end effectors error to joint velocities and the task space kinematic control law for both arms can be written as:

$$\dot{q} = J_a^T (J_a J_a^T)^{-1} K e \quad (7)$$

With

$$J_a = \begin{bmatrix} J_p(q) \\ J_{v\omega}(\dot{\phi}_d, q) \end{bmatrix} \quad (8)$$

e is the error vector $[e_p, e_r]$, K is the gain matrix and $J^+ = J_a^T (J_a J_a^T)^{-1}$ is the pseudoinverse of the matrix J_a .

6 Force control

The main objective of the admittance controller is to follow the forces acting in the end effector in each direction of the task space, by imposing a dynamic relation between the position of the end effector and the force applied to the object. The measurement from a force/torque sensor is used for designing the control law with a gain factor K . The output is then a desired Cartesian velocity resulting from the input force.

The UR10 arm does not provide any directly accessible means for the control via joint torques. We can use a force sensor, to implement an admittance controller, i.e. a controller which generates velocity commands based on the measured forces.

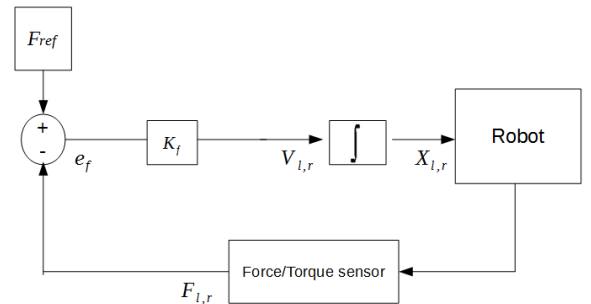

Figure 6: Diagram of the UR10 arm with admittance control

Denote that $X_{l,r} = (P_{l,r}, R_{l,r})$. As recommended in [14], [15] for force control, the control law can be written:

$$\begin{aligned}\vartheta_l &= \lambda K_f e_{fl} \\ \vartheta_r &= \lambda K_f e_{fr}\end{aligned}\quad (9)$$

with K_f is a diagonal matrix of damping coefficients, λ is a constant, such as $\lambda \in [0, 1[$ when $e_f < 0$ (moving forward) and $\lambda = 1$ when $e_f > 0$ (moving backwards).

In our case, we are just interested in the force between the two arms i.e. the grip force applied by the two end effectors. These forces lie along the line between the contacts, i.e. the line which is passing through both contact points. We then compute the normal (between the two grippers) vector of the two arms as :

$$\eta = \frac{P_l - P_r}{\|P_l - P_r\|}\quad (10)$$

The projection of the forces at the normal vector between the two end effectors (left arm and right arm) provides a possibility of controlling the robot for maintaining a stable grasp at the time of movement with respect to the direction of grasping.

$$\begin{aligned}\xi_l &= \eta^T F_l \\ \xi_r &= \eta^T F_r\end{aligned}\quad (11)$$

The force measured by the force/torque sensors are (F_L, F_R) . The force error of each arm is projected along the normal vector between the two end effectors meaning it is projected along the center of the sensors (force/torque sensor of each arm) to apply an equal force on the object. The force control law is:

$$X_{l,r} = \lambda K_f (\xi_{l,r}^d - \xi_{l,r}) \eta\quad (12)$$

$\xi_{l,r}^d$ the desired force.

By combining (7) and (12), the hybrid force/position control law becomes:

$$\dot{q} = J_a^T (J_a J_a^T)^{-1} K_f e + J^T (J J^T)^{-1} \lambda K_f e_f\quad (13)$$

7 Results

The low-level interface of the UR10 arm controller is executed with a frequency of 125 Hz. The time necessary for the robot to update a new command joint angle is 8ms for a valid consideration of input. We created our controllers using the package controller manager [15] implemented in ROS provide a hard-real time architecture consisting of loading, unloading, starting and stopping controllers. The experiments were conducted to move a cardboard box following a circular trajectory with radius of 0.2 m along a horizontal plan (figure 7).

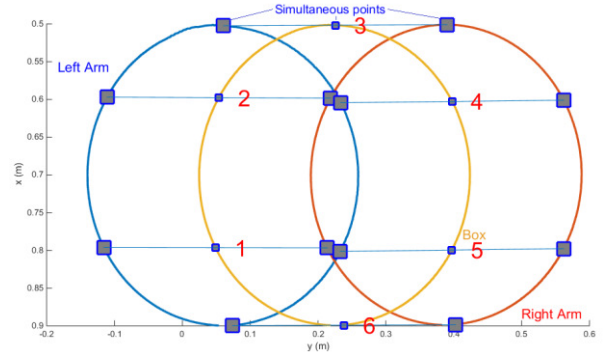

Figure 7: Trajectories of the left and right arms obtained from the trajectory of the cardboard box.

Our work consist in considering the trajectory of the object (figure 4) and deriving the motion of the arms. For this a path planning has been done to compute the postures of each arm according to the desired trajectory of the object chosen by the user.

$$\begin{aligned}P_g &= [X_g, Y_g, Z_g, \theta_g, \Psi_g, \phi_g] \\ P_{dl} &= [X_{dl}, Y_g + \frac{L}{2}, Z_{dl}, \theta_{dl}, \Psi_{dl}, \phi_{dl}]\end{aligned}\quad (14)$$

$$P_{dr} = [X_{dr}, Y_g - \frac{L}{2}, Z_{dr}, \theta_{dr}, \Psi_{dr}, \phi_{dr}]$$

The trajectory chosen for the object is:

$$(X_g - X_0)^2 + (Y_g - Y_0)^2 = R^2$$

R is the radius of the circle, P_g is the gripped object frame. P_{dl} , P_{dr} are the left and right end effector frames.

The box is grasped from an initial position and while still holding it, a trajectory is executed in space by both arms to check the performance of the controller. The performance is related to the fact that both the arms should enforce a good grasp so that the box doesn't fall down by slipping. The result is evaluated by observing the process and also monitoring the gripping distance between the two arms. This distance is equal to the width of the box. If the distance between arms remains the same from the starting point to the end of the trajectory or either it remains within a certain bound of minimal error, which still ensures good grasp by both arms. In the plots (figure 8) it can be observed that the grip force applied by the robot varies proportionally to the position error. It is observable that the force profile is almost constant when the offset (error) between the end effector position is minimum.

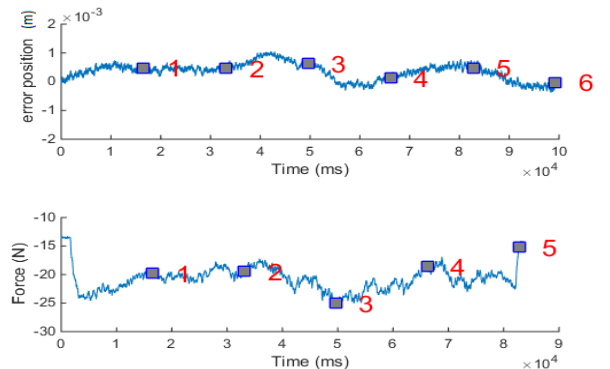

Figure 8: Position error $(P(t)-P_0)$ and force

The results shows the proportionality between the error and the force in the direction of the movement, in order to compensate the error and avoid falling of the box due to slippage. The robot was able to hold the box along a path with a collaborative behavior that is a composition of force and position for the compensation of the error.

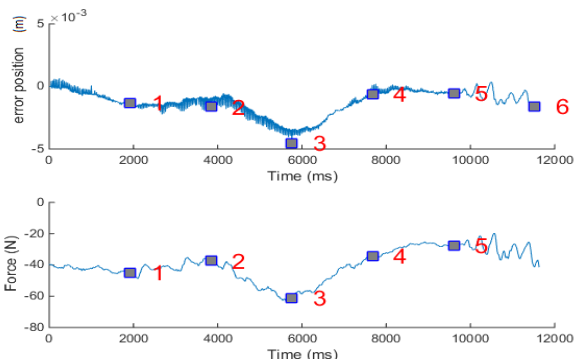

Figure 9: Position error ($P(t)-P_0$) and force in velocity $\times 8$

To evaluate the behavior of the controller a similar experience was derived in case of a velocity 8 times more than the previous one ($\times 8$). In this case (figure 9) the errors increased with the increase of speed. It was found that the maximum error was 1.4mm for the first experiment, and increased to 5.2mm when the speed is multiplied by 8 on the same trajectory. This show that the grip force applied also increases proportionally to compensate the error. The robot behavior show a good compensation, allowing small deviations from the desired trajectory and a good reaction to the position error during the trajectory.

8 Discussion and future work

In this research work we have tested a hybrid force position controller in a dual arm arrangement to test the grasping of packages in the industrial environment. The present controller has shown good performance with some limitations for handling a box. This leads to further investigation for the refinement of the controller for an optimal performance, in the presence of limitations and constraints which are, fixed orientation of the grippers, the material of the package, the rigidity and flexibility, and the speed of handling. This work has given an insight into the complexities involved in the process of grasping and placing in the industry, and what effective strategy can be employed to overcome the challenges.

9 References

[1] P. A. Fernando Almeida, Antonio Lopes, "Force impedance control: a new control strategy of robotic manipulators," 1999.
 [2] Y. H. Nurkan Yagiz and Y. Z. Arslan, "Load transportation by dual arm robot using sliding mode control," Journal of

Mechanical Science and Technology 24 (5) (2010) 1177-1184, 2010.

- [3] W. R. Woosoon Yim, Manoharan Selvarajan and Wells, "Sliding mode cooperative motion control of dual arm manipulators," *Artif Life Robotics* (1999) 3:166-169, 1999.
 [4] A.-M. Liu, JF, "Robust control of planar dual-arm cooperative manipulators," *Robotics and Computer Integrated Manufacturing*, 2000.
 [5] R. G. Bonitz and T. Hsia, "Robust internal-force based impedance control for coordinating manipulators - theory and experiments," in *Robotics and Automation, 1996. Proceedings., 1996 IEEE International Conference on* (Volume:1 Apr 1996)
 [6] C. O. Thomas Wimbock, *Dual-Arm Manipulation*, C. O. Thomas Wimbock, Ed. *Towards Service Robots for Everyday Environments Volume 76 of the series Springer Tracts in Advanced Robotics* pp 353-366, 13 March 2012.
 [7] L. V. M. K. Hamid Sadeghian, Fanny Ficuciello, "Global impedance control of dual-arm manipulation for safe interaction," in *10th IFAC Symposium on Robot Control, SYROCO2012, Dubrovnik, Croatia*.
 [8] X. Yun and V. Kumar., "An approach to simultaneous control of trajectory and interaction forces in dual-arm configurations," *Transactions on Robotics and Automation*, Vol. 7(5). pp. 618 - 625., 1991.
 [9] W. Kraus and J. M. Brennan, "Hybrid position/force coordination for dual arm IROS, 1997."
 [10] P. K. Kim, J. P. JiHun Bae, and J. P. MoonHong Baeg, "Control strategy for simultaneously inserting multiple boxes with dual arm manipulator," in *Ubiquitous Robots and Ambient Intelligence (URAI), 2013*.
 [11] R. J. R. Daniel Kruse, John T. Wen, "A sensor-based dual-arm tele-robotic system," *IEEE Transactions on Automation Science and Engineering* Volume: 12, Issue: 1, Jan. 2015, 07 August 201.
 [12] K. Benali, J. Brethé, F. Guérin and M. Gorka, "Dual arm robot manipulator for grasping boxes of different dimensions in a logistics warehouse," 2018 IEEE International Conference on Industrial Technology (ICIT), Lyon, 2018, pp. 147.
 [13] C. C. de Wit, B. Siciliano, and G. Bastin, *Task space control*. London: Springer 2 London, 1996, pp. 115–139.
 [14] F. L. Joris Sijs and R. R. GertWillem, "Combined position&force control for a robotic manipulator," in *International Conference on Rehabilitation Robotics*, June 12-15, Noordwijk, The Netherlands, 2007.
 [15] J. W. L. Wilfinger and S. Murphy, "Integral force control with robustness enhancement,," *IEEE Control System Magazine*, vol. 14, pp. 31–40, Feb.1994.