



HAL
open science

Stratégies d'ancêtre commun pour les réseaux RPL multi-chemins

Tomas Lagos Jenschke, Georgios Papadopoulos, Remous-Aris Koutsiamanis,
Nicolas Montavont

► **To cite this version:**

Tomas Lagos Jenschke, Georgios Papadopoulos, Remous-Aris Koutsiamanis, Nicolas Montavont. Stratégies d'ancêtre commun pour les réseaux RPL multi-chemins. CORES 2020 - 5ème Rencontres Francophones sur la Conception de Protocoles, l'Evaluation de Performance et l'EXpérimentation des Réseaux de Communication, Sep 2020, Lyon, France. pp.1-4. hal-02651685

HAL Id: hal-02651685

<https://hal.science/hal-02651685>

Submitted on 29 May 2020

HAL is a multi-disciplinary open access archive for the deposit and dissemination of scientific research documents, whether they are published or not. The documents may come from teaching and research institutions in France or abroad, or from public or private research centers.

L'archive ouverte pluridisciplinaire **HAL**, est destinée au dépôt et à la diffusion de documents scientifiques de niveau recherche, publiés ou non, émanant des établissements d'enseignement et de recherche français ou étrangers, des laboratoires publics ou privés.

Stratégies d'ancêtre commun pour les réseaux RPL multi-chemins

Tomas Lagos Jenschke¹, Georgios Z. Papadopoulos¹,
Remous-Aris Koutsiamanis¹ et Nicolas Montavont¹

¹IMT Atlantique, Irista, France

Le protocole de routage IPv6 pour les réseaux à faible puissance et fort taux de pertes (RPL) est conçu pour les réseaux Internet des objets (IoT) afin de générer des itinéraires entre les appareils avec un traitement minimal. Ce protocole crée une topologie de réseau DODAG (Destination Oriented Directed Acyclic Graph) grâce à l'utilisation de paquets de contrôle DODAG Information Object (DIO). Le DODAG achemine les paquets de données en amont vers le périphérique de destination. Afin d'obtenir un réseau fiable, nous implémentons la réplication et l'élimination des paquets (PRE) pour effectuer une transmission de données à chemins multiples via plusieurs périphériques parents. Cependant, il n'existe aucun moyen standard de sélectionner un chemin alternatif. Ce document présente trois types de sélection de parent alternatif (AP) suivant un modèle triangulaire. Nous nous concentrons sur l'analyse de ses performances en termes de retard et de compromis entre trafic réseau et fiabilité.

Mots-clefs : Multi-path, RPL, PRE, Determinism, LeapFrog Collaboration, LLN

1 Introduction

The use of Low Power and Lossy Network (LLN) technologies has impacted existing production modes within industry, influencing the automation of process chains. However, the quality of service that is required by Industry 4.0 conflicts with the nature of wireless technologies. This is because the industry is especially concerned about the reliability and determinism of a network, while wireless technologies are generally oriented to best effort. To adapt to these requirements, several standards and tools have been established. An existing standard that adapts wireless technologies to the industry is IPv6 Routing Protocol for Low-Power and Lossy Networks (RPL) [7]. This routing protocol creates a hierarchic network called a Destination Oriented Directed Acyclic Graph (DODAG), where all the upstream traffic goes to the DODAG root. In this paper, we propose the use of multi-path routing in a RPL network to provide more opportunities for a data packet to reach its destination using the least number of re-transmissions. We evaluate three types of Alternative Parent (AP) selection algorithms taking as reference the Braided pattern [5] and the LeapFrog Collaboration (LFC) [6], [4], [3] algorithm.

2 Background

2.1 IPv6 Routing Protocol for Low-Power and Lossy Networks (RPL)

RPL is a distance vector protocol that generates link routes between LLN devices. This protocol comprises a hierarchical topology in which all traffic flows to the Root node. RPL uses three types of control packets: the DODAG Informational Solicitation (DIS), the Destination Advertisement Object (DAO), and the DODAG Information Object (DIO). The last one of the three (the DIO) is the most relevant for our work, since it carries the information required to incorporate a node to its DODAG. We add new information to these packets to enable the operation of braided multi-path routing.

2.2 Packet Replication and Elimination (PRE)

Packet Replication and Elimination (PRE) aims to improve the reliability of a network by transmitting multiple copies of the same packet through multiple routes, i.e., the *Replication* function. To avoid redundant information, PRE only forwards the first packet that was received. The rest of the packet copies that arrive later are dropped, i.e., the *Elimination* function.

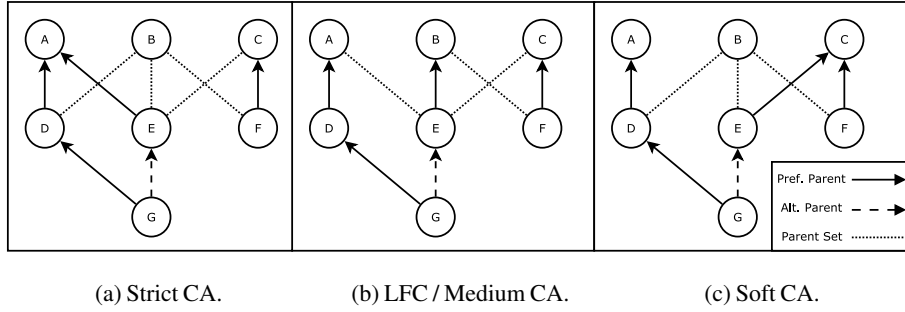

Figure 1: AP selection: Matching PPs (Fig. 1a), LFC (Fig. 1b), intersecting parent sets (Fig. 1c).

3 Problem Statement

Problems considered in LLN devices include their bounded power and their susceptibility to packet loss in transmissions. Given the multi-path policy, transmission reliability is improved but at the cost of more energy consumption. Therefore, a careful selection of multiple parents is required. In this section, we analyze the LFC algorithm, comparing it in scenarios that were missing or that were not taken into consideration in the original exposition of the algorithm [6].

3.1 Topology

In [6], the authors work with a topology with two parents per node. This environment limits the use of multi-path in RPL because only one node will be available to be an AP.

With LFC (also called Medium Common Ancestor (CA), see section 4), a node selects an AP if one element of its Parent Set (PS) is the parent of its Preferred Parent (PP) (i.e., its Preferred GrandParent (PGP)), as illustrated in Fig. 1b. If the node has more than two potential parents, then it can happen that the AP is not a node close to the PP, but farther away. As result, the AP may lead to the alternative path diverging far away from the preferred (i.e., main) path.

3.2 Flooding

The goal of LFC is to improve the reliability of a network through transferring copies of the same packet through its PP and an AP. If it is not possible to control the expansion of routes due to the use of multi-path, the number of copies will generate flooding in the network. It should be taken in consideration that LFC also uses overhearing and re-transmission, thus increasing the network traffic overhead of the approach.

4 Contribution

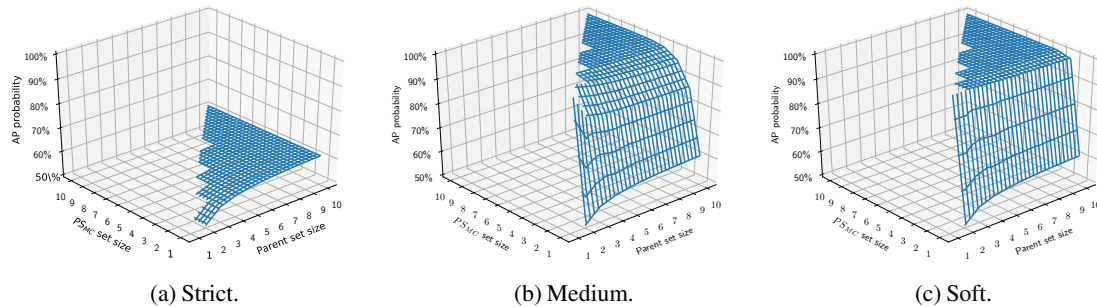

Figure 2: Probability of finding an AP through common ancestors vs. the PS size N and the PS_{MC} set size M .

In this paper, we define three types of algorithms to obtain an AP based on the braided pattern [1]. In a nutshell, the braided pattern selects a node as an AP, if it has a Common Ancestor (CA) with the PP. As illustrated in Fig. 1, three algorithms are defined by their level of restrictions to select this AP. The nodes report a subset

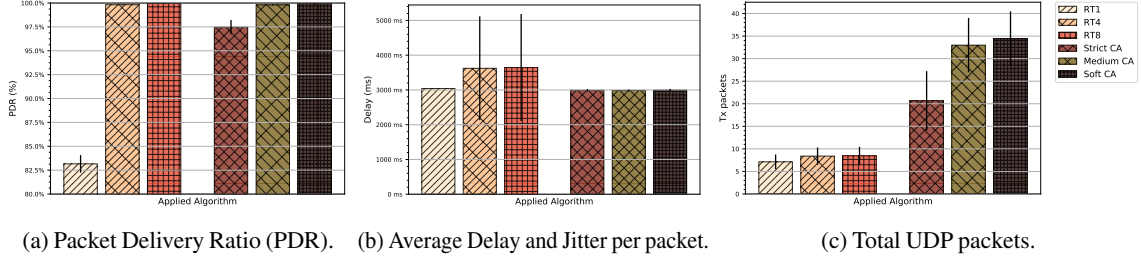

Figure 3: Performance evaluation

of their parent set in the PS extension [2] of the Node State and Attribute (NSA) object in the Metric Container (MC) of DIO messages (referred to as the PS_{MC} parent set here on). This PS_{MC} extension contains a fixed number of addresses M , while the number of parents in the parent set is N , with $1 \leq M \leq N$. The result of reporting just a subset of all the PS, instead of the whole set, is that AP selection becomes probabilistic.

The common general equations used to derive the probability $P(\exists CA)$ of having a CA and the probability $P(\exists AP)$ of having an AP in the next steps are:

$$P(\nexists AP) = (1 - P(\exists CA))^{N-1} \Rightarrow P(\exists AP) = 1 - P(\nexists AP) = 1 - (1 - P(\exists CA))^{N-1} \quad (1)$$

Given a node u that intends to select an AP and a candidate AP v , the strict CA algorithm is characterized by selecting its AP if this one has the same PP as the actual PP of the node, i.e., $PP(PP(u)) = PP(v)$. Fig. 1a illustrates the selection of an AP by using strict CA algorithm, where E will be selected as an AP since A is PP of E and D , thus the probability of finding an AP is represented by Equation 2.

$$P(\exists CA) = \frac{1}{N} \quad (2)$$

where $P(\exists CA)$ is the probability of having at least one CA and $P(\exists AP)$ is the probability of having at least one AP (the complement of probability $P(\nexists AP)$ of not being able to find any APs). Given these, the probability of finding an AP is calculated in Equation 3 and represented in Fig. 2a.

$$P(\exists AP) = 1 - \left(\frac{N-1}{N}\right)^{N-1} \quad (3)$$

The medium CA algorithms selects a node as AP if this one has within its neighbor set the preferred grandparent of the actual node. This algorithm is represented in Fig. 1b, where E will be selected as an AP because it has A within its neighbors set. It is worth mentioning that A does not have to be selected as a parent, but that it only exists within the neighbors set. The probability of having an AP is given by Equation 4.

$$P(\exists CA) = \frac{M}{N} \quad (4)$$

Using Equation 1, we obtain Equation 5 where its values are represented in Fig. 2b.

$$P(\exists AP) = 1 - \left(\frac{N-M}{N}\right)^{N-1} \quad (5)$$

The soft CA aims to select an AP if this node has a neighbor that exists within the set of neighbors of the current PP. As shown in Fig. 1c, E will be selected as AP since its B is also a neighbor of D .

In Equation 6, the probability $P(\exists CA)$ of obtaining a CA depends on the probability of having a common node in the two PS_{MC} parent sets via the PP and via the candidate AP.

$$P(\nexists CA) = \frac{\binom{N}{M} \cdot \binom{N-M}{M}}{\binom{N}{M} \cdot \binom{N}{M}} = \frac{\binom{N-M}{M}}{\binom{N}{M}} \Rightarrow P(\exists CA) = 1 - P(\nexists CA) = 1 - \frac{\binom{N-M}{M}}{\binom{N}{M}} \quad (6)$$

Finally, using Equation 1, the probability of finding an AP is represented by Equation 7 and is illustrated in Fig. 2c.

$$P(\exists AP) = 1 - \left[\frac{\binom{N-M}{M}}{\binom{N}{M}}\right]^{N-1} \quad (7)$$

5 Performance Evaluation

5.1 Simulation setup

The simulations were executed using the COOJA simulator developed by as part of the Contiki OS. We take the topology of [1], which consists of a matrix of 5x6 nodes, except for the source node and the root node located at the vertical ends of the topology. The routes are established vertically (from every node in layer l to every node in layer $l-1$) using RPL, while the sibling set corresponds to the nodes located horizontally (every node n in layer l has every other node at the same layer l as a sibling). Simulations were performed with several re-transmissions (RT) for single path (i.e., RT_n where n is the number of re-transmissions and $n+1$ is the number of total transmissions), while for multi-path they were performed with RT1. To have a realistic set-up, 1000 data packets were transmitted with uniformly random link quality variation between 70% and 100%.

5.2 Performance results

In terms of PDR, the probability of having an AP directly affects performance, since a greater number of forwarding nodes leads to a larger number of packet copies, which in turn increases reliability. On the other hand, a greater number of re-transmissions also leads to an improvement in the PDR. This can be seen in Fig. 3a where RT4 and RT8 reach almost 100% and in the ascending results of each CA algorithm. In terms of delay, it is observed that increasing the number of re-transmissions leads to an increase of delay. This is due to the number of slotframes required for each re-transmission and, therefore, an increase in the delay, as it can be seen in Fig. 3b. Finally, as shown in Fig. 3c, the use of multi-path will increase the traffic of data packets depending on how strict the algorithm is, more precisely, between the strict CA and medium CA algorithms. This is because the probability of obtaining an AP in Strict CA is much lower than the probabilities that have Medium CA and Soft CA, which means a smaller number of nodes to use.

6 Conclusions

For the topology analyzed, the minimum probability of having an AP is 60%, increasing as the number of parents increases and as the number of addresses contained in the PS extension of the NSA metric in DIO messages increases. We identified that although the overall network power consumption is higher for our algorithms in comparison to the default single-path algorithms, the trade-off presented is useful for the intended industrial network performance applications. Therefore the trade-off must be balanced based on the requirements of a given system.

References

- [1] T. L. Jenschke, G. Z. Papadopoulos, R. Koutsiamanis, and N. Montavont. Alternative parent selection for multi-path rpl networks. In *2019 IEEE 5th World Forum on Internet of Things (WF-IoT)*, pages 533–538, 2019.
- [2] R. Koutsiamanis, G. Papadopoulos, N. Montavont, and P. Thubert. Common Ancestor Objective Function and Parent Set DAG Metric Container Extension. Internet-Draft draft-ietf-roll-nsa-extension-08 [work-in-progress], IETF, ROLL WG, March 2020.
- [3] R. A. Koutsiamanis, G. Z. Papadopoulos, X. Fafoutis, J. M. Del Fiore, P. Thubert, and N. Montavont. From Best-Effort to Deterministic Packet Delivery for Wireless Industrial IoT Networks. *IEEE Transactions on Industrial Informatics*, 14:4468–4480, 2018.
- [4] R.-A. Koutsiamanis, G. Z. Papadopoulos, T. Lagos Jenschke, P. Thubert, and N. Montavont. Meet the PAREO Functions: Towards Reliable and Available Wireless Networks. In *Proceedings of the IEEE International Conference on Communications (ICC)*, 2020.
- [5] P. Minet, I. Khoufi, and A. Laouiti. Increasing Reliability of a TSCH Network for the Industry 4.0. In *Proceedings of the 16th IEEE International Symposium on Network Computing and Applications (NCA)*, 2017.
- [6] G. Z. Papadopoulos, T. Matsui, P. Thubert, G. Texier, T. Watteyne, and N. Montavont. Leapfrog Collaboration: Toward Determinism and Predictability in Industrial-IoT applications. In *Proceedings of the IEEE International Conference on Communications (ICC)*, 2017.
- [7] T. Winter, P. Thubert, A. Brandt, J. Hui, R. Kelsey, P. Levis, K. Pister, R. Struik, JP. Vasseur, and Alexander R. RPL: IPv6 Routing Protocol for Low-Power and Lossy Networks. IETF RFC 6550, 2012.