



HAL
open science

Self-consistent quasi-static parallel electric field associated with substorm growth phase

O. Le Contel, R. Pellat, A. Roux

► **To cite this version:**

O. Le Contel, R. Pellat, A. Roux. Self-consistent quasi-static parallel electric field associated with substorm growth phase. *Journal of Geophysical Research Space Physics*, 2000, 105 (A6), pp.12945-12954. 10.1029/1999JA900499 . hal-02550835

HAL Id: hal-02550835

<https://hal.science/hal-02550835v1>

Submitted on 28 Aug 2020

HAL is a multi-disciplinary open access archive for the deposit and dissemination of scientific research documents, whether they are published or not. The documents may come from teaching and research institutions in France or abroad, or from public or private research centers.

L'archive ouverte pluridisciplinaire **HAL**, est destinée au dépôt et à la diffusion de documents scientifiques de niveau recherche, publiés ou non, émanant des établissements d'enseignement et de recherche français ou étrangers, des laboratoires publics ou privés.

Self-consistent quasi-static parallel electric field associated with substorm growth phase

O. Le Contel

Centre d'Etude des Environnements Terrestre et Planétaires, Vélizy, France

R. Pellat

Centre de Physique Théorique, Ecole Polytechnique, Palaiseau, France

A. Roux

Centre d'Etude des Environnements Terrestre et Planétaires, Vélizy, France

Abstract. A new approach is proposed to calculate the self-consistent parallel electric field associated with the response of a plasma to quasi-static electromagnetic perturbations ($\omega < k_{\parallel}v_A$, where v_A is the Alfvén velocity and k_{\parallel} the parallel component of the wave vector). Calculations are carried out in the case of a mirror geometry, for $\omega < \omega_b$ (ω_b being the particle bounce frequency). For the sake of simplification the β of the plasma is assumed to be small. Apart from this restriction, the full Vlasov-Maxwell system of equations has been solved within the constraints described above ($\omega < k_{\parallel}v_A$ and $\omega < \omega_b$) by [Le Contel *et al.*, this issue] (LC00, hereafter), who describe self-consistently the radial transport of particles during the substorm growth phase. LC00 used an expansion in the small parameter T_e/T_i (T_e/T_i is typically 0.1 to 0.2 in the plasma sheet) to solve the quasi-neutrality condition (QNC). To the lowest order in $T_e/T_i < 1$, they found that the QNC implies (1) the existence of a global electrostatic potential Φ_0 which strongly modifies the perpendicular transport of the plasma and (2) the parallel electric field vanishes. In the present study, we solve the QNC to the next order in T_e/T_i and show that a field-aligned potential drop proportional to T_e/T_i does develop. We compute explicitly this potential drop in the case of the substorm growth phase modeled as in LC00. This potential drop has been calculated analytically for two regimes of parameters, $\bar{\omega}_d < \omega$ and $\bar{\omega}_d > \omega$ ($\bar{\omega}_d$ being the bounce averaged magnetic drift frequency equal to $k_y \bar{v}_d$, where k_y is the wave number in the y direction and \bar{v}_d the bounce averaged magnetic drift velocity). The first regime ($\bar{\omega}_d < \omega$) corresponds to small particle energy and/or small k_y , while the second regime ($\bar{\omega}_d > \omega$) is adapted to large energies and/or large k_y . In particular, in the limit $\bar{\omega}_d < \omega$ and $|\bar{v}_d| < |u_y|$, where u_y is the diamagnetic velocity proportional to the pressure gradient, we find a parallel electric field proportional to the pressure gradient and directed toward the ionosphere in the dusk sector and toward the equator in the dawn sector. This parallel electric field corresponds to a potential drop of a few hundred volts that can accelerate electrons and produce a differential drift between electrons and ions.

1. Introduction

A proper description of the transport of the plasma during the growth phase is a prerequisite to the understanding of what triggers substorm breakup. Yet, in a mirror geometry like the Earth's magnetosphere, there are serious difficulties when the frequency ω of the magnetic field variations is lower than the bounce fre-

quency of the particles ω_b (see, for instance, Rosenbluth and Varma [1967], Rutherford and Frieman [1968], Antonson and Lane [1980], and Hurricane *et al.* [1994]). A new kinetic formalism has been developed by Pellat *et al.* [1994] to describe the time-dependent transport associated with low-frequency electrostatic perturbations for a plasma confined in a multipole-type configuration. Hurricane *et al.* [1995] extended this formalism to electromagnetic perturbations, satisfying $\omega > \omega_*$, $\bar{\omega}_d$ (ω_* being the diamagnetic drift frequency and $\bar{\omega}_d$ being the bounce averaged curvature-gradient magnetic drift frequency), with the purpose of describing insta-

Copyright 2000 by the American Geophysical Union.

Paper number 1999JA900499.
0148-0227/00/1999JA900499\$09.00

bilities that could develop in the far tail. In all cases [Pellat *et al.*, 1994; Hurricane *et al.*, 1995; Le Contel *et al.*, this issue, hereinafter referred to as LC00], the solution of Vlasov and quasi-neutrality equations was shown to contain a new contribution to the perturbed electrostatic potential. This new term is constant on a given magnetic field line but varies across the magnetic field. It develops in response to an externally applied perturbation. Using an expansion in the small parameter T_e/T_i (T_e/T_i being the ratio between the electronic and ionic temperatures), LC00 calculated explicitly this potential without any assumption on the frequency of the perturbations. LC00 showed that the electrostatic field (corresponding to the new contribution of the perturbed electrostatic potential) tends to reduce/shield the inductive part of the electric field. Owing to this partial shielding, the azimuthal electric field is expected to be small during the growth phase, a situation that corresponds to observations. This electrostatic potential cannot be obtained from MHD and requires a kinetic approach. Thus the perpendicular transport of the plasma, for the conditions prevailing during the growth phase, can be interpreted as the response of the plasma to quasi-static perturbations when the QNC is enforced. In the particular case of the magnetic field variations during the substorm growth phase, LC00 found that the azimuthal electric field changes direction with latitude; it is directed eastward close to the magnetic equator, whereas off-equator it is directed westward. Finally, LC00 showed that enforcing the QNC implies there is no field aligned potential drop to the lowest order in T_e/T_i .

In the present paper, we further develop this approach by considering the terms of the order T_e/T_i in the expansion of the QNC. The main purpose is to examine whether the parallel electric field remains null to the order T_e/T_i in the case of a time-dependent transport, for quasi-static conditions $\omega < k_{\parallel}v_A$ (k_{\parallel} being the parallel component of the wave vector and v_A being the Alfvén velocity), $\omega < \omega_b$ and $k_{\perp}\rho < 1$ (k_{\perp} being the perpendicular component of the wave vector and ρ the Larmor radius of the particles). During substorms, there are some strong, though indirect evidences, for parallel electric fields. In particular, large potential drops have been found above the auroral ionosphere within an altitude range of 5000-15,000 km, causing energization of the electrons responsible for the aurorae. In this region the parallel electric field may be very large. Other locations, where parallel electric fields are expected, are reconnection regions and current disruption regions. An indirect evidence is provided by electron beams observed near the magnetic equator during and after substorm breakup [McIlwain, 1975; Parks *et al.*, 1977]. The above examples show that parallel electric fields are often present, but these examples correspond to extreme situations where the integrated parallel electric field ($E_{\parallel} = -\nabla_{\parallel}\Phi - \partial A_{\parallel}/\partial t$, where Φ is the electrostatic potential, A_{\parallel} is the parallel component of the

magnetic vector potential, and t is the time) is so large that the variation in the electron energy is of the order of, or exceeds, their thermal energy (a few keV). In the present paper we limit ourselves to a simpler situation where the potential drop is less than the electron thermal energy, which allows a linearization of the problem. Such small field-aligned potential drops corresponding to relatively quiet periods are likely to occur in the tail as suggested by recent observations of low-energy electron beams (100-300 eV) during a dusk-dawn crossing of the near-Earth magnetotail (10 R_E , R_E being the Earth radius) by Geotail [Frank *et al.*, 1996]. Also, for the sake of simplification, we do not take into account the effect of the ionosphere; the low-altitude electric fields are not described. Yet we show that the quasi-neutrality of the plasma implies the existence of a parallel electric field, even in the linear regime; a situation which is likely to occur during substorm growth phase as previously noted by Koskinen *et al.* [1996]. In the present paper, we use the solution of Ampère's law obtained in LC00 to describe the stretching of the magnetic field lines during the growth phase and solve the QNC to the next order in (T_e/T_i) , this is done in section 2. The parallel electric field is calculated analytically for various parameter regimes in section 3. Finally, in section 4 we discuss which regime is well adapted to the characteristic conditions of the substorm growth phase.

2. Quasi-neutrality Condition

For long perpendicular wavelength electromagnetic perturbations ($k_{\perp}\lambda_D \ll 1$ where $\lambda_D = \sqrt{\epsilon_0 k_B T / (n_0 q^2)}$ is the Debye length, ϵ_0 is the vacuum permittivity, k_B the Boltzmann constant, T the temperature, n_0 the density, and q the charge of particles), the Gauss's equation reduces to a local charge neutrality condition. LC00 showed that after a gyrophase integration, summation over streaming and antistreaming particles, with the usual wavelength ordering $k_{\perp}\rho_j < 1$ (ρ_j being the Larmor radius of the particles of species j), with the gauge $\delta A_y = 0$ and in the limit $T_e < T_i$, the QNC can be written as

$$\begin{aligned} & \int \frac{4\pi B dE d\mu}{m_e^2 |v_{\parallel}|} f_{0e} \left((\delta\Phi - \overline{\delta\Phi}) + (\lambda - \overline{\lambda}) \right) \\ & + \frac{T_e}{T_i} \left[(\delta\Phi - \overline{\delta\Phi}) + (\lambda - \overline{\lambda}) \right] = \frac{T_e}{T_i} \int \frac{4\pi B dE d\mu}{m_i^2 |v_{\parallel}|} f_{0i} \\ & \cdot \left(\frac{\overline{\omega}_{di} (\overline{\omega}_{di} - \omega_{*i})}{\omega (\omega + \overline{\omega}_{di})} (\overline{\delta\Phi} + \overline{\lambda}) + \frac{\omega_{*i} - \overline{\omega}_{di}}{\omega + \overline{\omega}_{di}} (\overline{\Xi}_i) \right), \quad (1) \end{aligned}$$

where f_{0j} is the equilibrium distribution function of species j ($j = i, e$), assumed to be a Maxwellian distribution function ($f_{0j} = n_{0j} [m_j / (2\pi T_j)]^{3/2} \exp(-E/T_j)$). The temperature and mass are noted T_j, m_j , respectively. The variable λ is defined by $\lambda = i\omega \int^l dl' \delta A_{\parallel} l$, $\omega_{*i} = k_y u_{yi}$ is the ion diamagnetic drift frequency where u_y is the diamagnetic drift velocity and k_y is the wave

number in the y direction (azimuthal), $\omega_{di} = k_y v_{di}$ is the ion gradient-curvature magnetic drift frequency where v_{di} is the ion magnetic drift velocity. The integral over velocity space has been written in local field-aligned cylindrical coordinates: $d^3v = 4\pi B dE d\mu / (m^2 \cdot |v_{\parallel}|)$, where $E = \frac{1}{2} m v_{\parallel}^2 + \mu B$ is the kinetic energy and $\mu = \frac{1}{2} m v_{\perp}^2 / B$ is the magnetic moment. We have assumed that the electromagnetic perturbation is periodic in time and in space (across the magnetic field)

$$\delta\Phi(\vec{r}, t), \lambda(\vec{r}, t) = \widehat{\delta\Phi}(\vec{k}_{\perp}, \omega, l), \widehat{\lambda}(\vec{k}_{\perp}, \omega, l) \cdot \exp\left[i(\vec{k}_{\perp} \cdot \vec{r}_{\perp} + \omega t)\right]. \quad (2)$$

For simplicity, the hat symbol and the exponential factor have been omitted. The bar in (1) indicates bounce averaging. The function Ξ_i is defined by $\Xi_i = \omega_{di} \lambda / \omega + i\mu \delta B_{\parallel} / q_i$. LC00 showed that the quasi-neutrality of the flux tube requires the existence of a new contribution, Φ_0 , of the perturbed electrostatic potential which is constant for a given magnetic field line (but varies across the equilibrium magnetic field). This potential is calculated self-consistently from the magnetic field variations and is given by (14) in LC00. This potential strongly modifies the transport of the plasma; namely, it reduces the effect of the inductive component of the perpendicular electric field. Furthermore, LC00 showed that the parallel electric field vanishes to the lowest order in T_e/T_i .

To determine the field-aligned potential drop which can exist to the first order in (T_e/T_i) , we have to solve the QNC to this order. Thus, in this case, $\delta\Phi(l) + \lambda(l) = \Phi_0 + \delta\phi(l)$, where $\delta\phi(l)$ is a first-order term proportional to (T_e/T_i) . Equation (1) becomes

$$\int \frac{4\pi B dE d\mu}{m_e^2 |v_{\parallel}|} f_{0e} (\delta\phi - \overline{\delta\phi}) = \frac{T_e}{T_i} \int \frac{4\pi B dE d\mu}{m_i^2 |v_{\parallel}|} f_{0i} \cdot \left[\frac{\overline{\omega_{di}} (\overline{\omega_{di}} - \omega_{xi})}{\omega (\omega + \overline{\omega_{di}})} \Phi_0 + \frac{\omega_{xi} - \overline{\omega_{di}}}{\omega + \overline{\omega_{di}}} (\Xi_i) \right]. \quad (3)$$

Provided that $\omega < \omega_b$, (3) is valid for any quasi-static or low-frequency perturbations. Thus a parallel electric field will be present in response to electromagnetic perturbations applied in a mirror geometry like the near-Earth magnetic tail. Therefore parallel electric fields should exist not only during active periods (breakup) or at low altitudes (inverted V) but also during relatively quiet periods such as the substorm growth phase, as will be seen in the next sections. Unfortunately, it is not possible to find a general analytical solution of the integral equation (3) except when ions and electrons are stochastic. In such a case, it can be shown that the right-hand side (RHS) of (3) cancels exactly due to fast pitch-angle scattering on the two species. Therefore there is no parallel electric field for a completely stochastic plasma.

It will be shown in the next section that an analytical solution can be obtained for the region close to the

Earth. In this region, electrons and ions are in an adiabatic regime and the β of the plasma can be assumed to be small therefore the local currents can be neglected. Thus the magnetic field line stretching can be modeled as the effect of a forcing current located farther in the tail on the quasi-dipolar equilibrium magnetic field (see LC00 for more details). We show that a self-consistent parallel electric field, developing in response to the quasi-static change of the magnetic field lines, can be calculated in the near-Earth plasma sheet (NEPS).

Using the two-dimensional (2-D) dipole [Huang and Birmingham, 1994] to describe the equilibrium magnetic field close to the Earth, LC00 solved Ampère's law in the quasi-static limit with an external forcing current given by

$$\delta j_{ext}(L, k_y, \theta, \omega) = \delta j_{eq}(k_y, \omega) \delta(L - L_c) \sin^{2n} \theta \cdot [(2n + 1) \cot^2 \theta - 1], \quad (4)$$

where θ is the colatitude, L is the equatorial crossing distance of the relevant field line, L_c is the radial location of the forcing current, n determines the degree of localization near the magnetic equator, and $\delta j_{eq}(k_y, \omega)$ is the Fourier transform of the current. The time variation and the dependence along the y direction of the real electrical current have been chosen to correspond to observations carried out during the growth phase (see LC00 for a more detailed discussion):

$$\begin{aligned} \delta j_{eq}(y, t) &= \frac{1}{2\pi} \int_{-\infty}^{+\infty} d\omega \int_{-\infty}^{+\infty} dk_y \widehat{\delta j_{eq}}(k_y, \omega) \\ &\cdot \exp[i(k_y y + \omega t)] \\ &= \delta j_m \exp\left(-\frac{y^2}{\Delta^2}\right) \exp(\gamma t). \end{aligned} \quad (5)$$

In the limit $|k_y|L > 1$ and $|k_y(L - L_c)| < 1$, they obtained for λ

$$\lambda(L, k_y, \theta, \omega) \simeq \lambda_{neq} [c_n(L, k_y) + (\sin^2 \theta)^{n+1}], \quad (6)$$

where we have defined $c_n(L, k_y) = (n + 1)! / (|k_y(L - L_c)|)^{n+1}$ and $\lambda_{neq} = 1 / (4(n + 1)) \mu_0 (|k_y|/k_y) \omega \delta j_{eq}(k_y, \omega) \cdot L_c^2 L$. The other component of the perturbed magnetic field is given by

$$\begin{aligned} \delta B_{\parallel} &= -\frac{\mu_0 \delta j_{eq}(k_y, \omega)}{2} \frac{L_c^2}{L} \sin^{2n} \theta \left[(2n + 1) \right. \\ &\left. - (2n + 2) \sin^2 \theta \right] \{H(L - L_c) - H[-(L - L_c)]\}, \end{aligned} \quad (7)$$

where H denotes the Heaviside function. The nonlocal bounce-averaged terms at the RHS of (3) have been computed in LC00 (see Appendix B):

$$\begin{aligned} \frac{\overline{\omega_d \lambda}}{\omega} &= \frac{\overline{\omega_d}}{\omega} \lambda_{neq} \left[c_n + 2 \sum_{k=0}^{n+1} (-1)^k C_{n+1}^k \frac{(2k-1)!!}{(2k+2)!!} \right. \\ &\left. \cdot \left(1 - \frac{\mu B_{eq}}{E}\right)^k \left(1 + k \frac{\mu B_{eq}}{E}\right) \right], \end{aligned} \quad (8)$$

$$\Phi_0 = (c_n + S_n) \lambda_{neq}, \quad (9)$$

where S_n is defined by

$$S_n = \sum_{k=0}^{n+1} (-1)^k C_{n+1}^k \frac{(2k-1)!!}{(2k+2)!!} \cdot \sum_{j=0}^k (-1)^j C_k^j \frac{(2j)!!}{2^{j-1}(j+1)!} \left(1 + k \frac{(j+1)}{(j+2)}\right). \quad (10)$$

LC00 showed that in the limit $|k_y|L > 1$ $\overline{\mu\delta B_{\parallel}}/q < \overline{\omega_d\lambda}/\omega$; therefore we take

$$\overline{\mu\delta B_{\parallel}}/q \simeq 0. \quad (11)$$

In the next section, we solve the QNC to the next order in (T_e/T_i) and give explicit analytical expressions for the field-aligned potential variation.

3. Self-consistent Parallel Electric Field

3.1. General Case

Equation (3) defines the solution to the order T_e/T_i of the QNC, in response to a perturbation defined by (6), (7), and (9). Taking into account (8) and (11), M , the RHS term of (3), becomes

$$M = \frac{T_e}{T_i} \int \frac{4\pi B dE d\mu}{m_i^2 |v_{\parallel}|} f_{0i} \left[\frac{\overline{\omega_{di}} (\overline{\omega_{di}} - \omega_{*i})}{\omega (\omega + \overline{\omega_{di}})} \right] \cdot \left[S_n - 2 \sum_{k=0}^{n+1} (-1)^k C_{n+1}^k \frac{(2k-1)!!}{(2k+2)!!} \right] \cdot \left(1 - \frac{\mu B_{eq}}{E}\right)^k \left(1 + k \frac{\mu B_{eq}}{E}\right) \lambda_{neq}. \quad (12)$$

Remembering that for a 2-D dipole, the bounce-averaged curvature-gradient magnetic drift frequency does not depend on the magnetic moment μ , the first term between brackets of the expression of M in (12) is also independent of μ . Therefore the μ integration in (12) can easily be performed thanks to the relation (D2) of LC00. We obtain

$$M = n_{0i} K_i (S_n - 2R_n) \lambda_{neq}, \quad (13)$$

where K_i is defined by

$$K_i = \frac{T_e}{T_i} \frac{1}{n_{0i}} \int \frac{4\pi \sqrt{2m_i} E dE}{m_i^2} f_{0i} \left[\frac{\overline{\omega_{di}} (\overline{\omega_{di}} - \omega_{*i})}{\omega (\omega + \overline{\omega_{di}})} \right], \quad (14)$$

and R_n by

$$R_n = \sum_{k=0}^{n+1} (-1)^k C_{n+1}^k \frac{(2k-1)!!}{(2k+2)!!} \sum_{j=0}^k (-1)^j C_k^j \frac{(2j)!!}{(2j+1)!!} \cdot \left(\frac{B_{eq}}{B}\right)^j \left(1 + k \left(\frac{B_{eq}}{B}\right) \frac{2j+2}{2j+3}\right). \quad (15)$$

LC00 have shown that, basically, the transport depends very little on n . The only change introduced by modif-

ing n is the degree of localization, close to the equator. For larger n the perturbation is localized closer to the magnetic equator and therefore the properties of the transport also change more rapidly along the field line. For simplicity, in the following calculations, we fix the value of n to zero. We consider a Fourier decomposition of $\widetilde{\delta\phi}$ with respect to the colatitude θ :

$$\widetilde{\delta\phi} = \sum_{p=1}^{\infty} (a_p \cos p\theta + b_p \sin p\theta). \quad (16)$$

The term $p = 0$ is not included because the structure of the left-hand side (LHS) of (3), $(X - \overline{X})$, leads to the cancellation of any constant term. Thus the first nonzero terms begin for $p = 1$. The RHS term, M , can be written as a function of $\cos p\theta$; for $n = 0$ it is simply given by

$$M = n_{0i} K_i \left[\frac{1}{30} + \frac{1}{15} \cos 2\theta - \frac{1}{60} \cos 4\theta \right] \lambda_{0eq}. \quad (17)$$

We notice that (1) the RHS of (17) contains only even powers of $\cos p\theta$, and (2) the highest value of p in (17) is 4; higher harmonics vanish. We therefore assume that $\widetilde{\delta\phi}$ only contains terms in $\cos 2\theta$ and $\cos 4\theta$; an assumption that will be verified later, therefore the solution obtained from this expansion is exact. With this expansion the field-aligned perturbed potential $\widetilde{\delta\phi}$ writes

$$\widetilde{\delta\phi} = \sum_{l=1}^2 a_{2l} \cos 2l\theta. \quad (18)$$

The bounce average value of $\widetilde{\delta\phi}$ is

$$\overline{\delta\phi} = -\frac{\mu B_{eq}}{E} \left[a_2 + 2a_4 \left(1 - \frac{3}{2} \frac{\mu B_{eq}}{E}\right) \right]. \quad (19)$$

The remaining double integral, in the LHS of (3), can be calculated from (D2) of LC00 and by taking into account the following identity:

$$\int_0^{\infty} E^{k-1/2} e^{-E/T} dE = \frac{\sqrt{\pi}}{2^k} (2k-1)!! T^{k+1/2}, \quad (k \geq 1). \quad (20)$$

Combining (18), (19), and (20), one gets

$$\int \frac{4\pi B dE d\mu}{m_e^2 |v_{\parallel}|} f_{0e} \overline{\delta\phi} = -\frac{2}{3} n_{0e} \frac{B_{eq}}{B} \cdot \left[a_2 + 2a_4 - \frac{12}{5} a_4 \frac{B_{eq}}{B} \right]. \quad (21)$$

With the help of the simple relation $B_{eq}/B = \sin^2 \theta = (1 - \cos 2\theta)/2$, the expression (21) becomes

$$\int \frac{4\pi B dE d\mu}{m_e^2 |v_{\parallel}|} f_{0e} \overline{\delta\phi} = -n_{0e} \left[\frac{1}{3} a_2 + \frac{1}{15} a_4 + \cos 2\theta \left(-\frac{1}{3} a_2 + \frac{2}{15} a_4 \right) + \cos 4\theta \left(-\frac{1}{5} a_4 \right) \right]. \quad (22)$$

We notice that the first two even terms in $\cos p\theta$ considered in the Fourier series do not provide terms in $\sin p\theta$, nor terms in $\cos p\theta$ with p odd, nor terms in $\cos p\theta$ with $p \geq 4$. Thus the higher-order terms ($p > 4$), which have not been considered in the above expansion, are solution of the following system of equations:

$$\sum_p \xi_p X_p = 0, \quad (23)$$

where $X_p = b_p, a_{2l+1}, a_{2l}$. A trivial solution is

$$b_p = 0 \quad (\forall p), \quad a_{2l+1} = 0 \quad (\forall l), \quad a_{2l} = 0 \quad (l > 2). \quad (24)$$

It was therefore justified to neglect terms with $p > 4$ as well as terms in $\sin p\theta$ and $\cos p\theta$ (p being odd). Therefore (17) and (22) allow us to write (3), as a function of $\cos 2\theta$ and $\cos 4\theta$, in the following form:

$$n_{0e} \left[a_2 \cos 2\theta + a_4 \cos 4\theta + \left\{ \frac{1}{3} a_2 + \frac{1}{15} a_4 + \cos 2\theta \left(-\frac{1}{3} a_2 + \frac{2}{15} a_4 \right) + \cos 4\theta \left(-\frac{1}{5} a_4 \right) \right\} \right] = n_{0i} K_i \cdot \left[\frac{1}{30} + \cos 2\theta \frac{1}{15} + \cos 4\theta \left(-\frac{1}{60} \right) \right]. \quad (25)$$

Taking $n_{0e} = n_{0i}$ at the equilibrium, (25), which should be satisfied for any value of θ , is equivalent to a system of three equations:

$$\frac{1}{3} a_2 + \frac{1}{15} a_4 = \frac{1}{30} K_i, \quad (26)$$

$$\frac{2}{3} a_2 + \frac{2}{15} a_4 = \frac{1}{15} K_i, \quad (27)$$

$$\frac{4}{5} a_4 = -\frac{1}{60} K_i. \quad (28)$$

Finally, from (27) and (28), we find immediately: $a_4 = -K_i/48$ and $a_2 = 5K_i/48$. Equation (26) is then identically verified. The perturbed electrostatic potential, obtained from the QNC to the first order in (T_e/T_i) , is therefore

$$\overline{\delta\phi} = K_i e(\theta), \quad (29)$$

where we have defined the function $e(\theta) = A_2 \cos 2\theta + A_4 \cos 4\theta$, with $A_2 = 5/48$ and $A_4 = -1/60$. The parallel electric field is given by

$$\delta E_{\parallel} = -\frac{\partial}{\partial l} (\delta\Phi) - \frac{\partial}{\partial t} (\delta A_{\parallel}) \quad (30)$$

$$\delta E_{\parallel} = -\frac{\partial}{\partial l} \left(\Phi_0 - \lambda + \overline{\delta\phi} \right) - \frac{\partial \lambda}{\partial t}, \quad (31)$$

remembering that $\delta\Phi + \lambda = \Phi_0 + \overline{\delta\phi}$, where Φ_0 is independent of l and that $dl = -Ld\theta$, we obtain

$$\delta E_{\parallel} = \frac{1}{L} \frac{\partial}{\partial \theta} (\overline{\delta\phi}) = \frac{1}{L} K_i e'(\theta), \quad (32)$$

where $e'(\theta)$ is the derivative of $e(\theta)$ with respect to θ . We have also performed the calculation for $n = 2$ and, in Figure 1, we plot the functions $e(\theta)$ and $e'(\theta)$ for these two values of n . As already mentioned, the results depend little upon n . Indeed, we note that whatever the value of n , $e'(\theta)$ goes to zero at the equator and has two symmetrical extrema off-equator. The parallel electric field, however, is more localized as n increases. In the following discussion, we will assume that we are located in the Northern Hemisphere ($0 \leq \theta \leq \pi/2 \iff e'(\theta) < 0$). To go further and perform the energy integration, we need to simplify the term between brackets intervening in the expression (14) of K_i . We consider successively two extreme cases for which we are able to compute completely the parallel electric field. First, in subsection 3.2, we assume that the curvature-gradient magnetic drift frequency is smaller than the frequency of the perturbation. Since $\overline{\omega}_d = k_y \overline{v}_d$, where \overline{v}_d is proportional to the particle energy, this assumption is equivalent to consider that the particle energy is small or that the scale length of the perturbation in the y direction ($2\pi/k_y$) is large. Second, in subsection 3.3 we assume that $\overline{\omega}_d$ is larger than ω which corresponds to high-energy particles or to perturbations highly localized in longitude.

3.2. Low Magnetic Drift Limit ($\overline{\omega}_d < \omega$)

We assume that the particles, that ensure the quasi-neutrality, are low energy particles satisfying $\omega > \overline{\omega}_d$. This assumption means that the characteristic time for particles to escape from the perturbed region under the effect of their magnetic drift velocity \overline{v}_d , is long com-

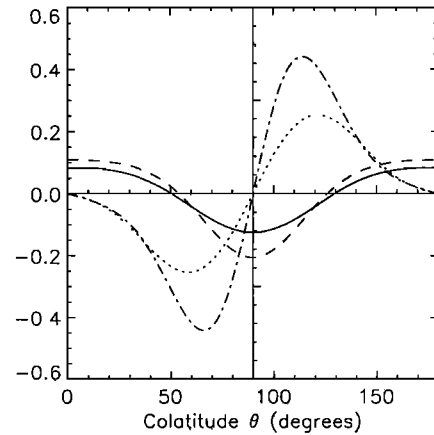

Figure 1. Functions $e(\theta)$ plotted with solid line (dashed line) for $n = 0$ ($n=2$) and $e'(\theta)$ plotted with dotted line (dotted-dashed line) for $n=0$ ($n=2$).

pared to the duration of the perturbation. For instance, at the geostationary orbit, thermal ions with 10 keV in the plasma sheet have a magnetic drift velocity of the order of 5 km/s. If the perturbed region has a width of $4 R_E$ in the y direction, thermal ions need 90 min to cross the stretched region. This time exceeds the duration of the growth phase. Therefore, in this limit, the term between brackets of K_i in (14) can be written:

$$\frac{\bar{\omega}_{di}(\bar{\omega}_{di} - \omega_{xi})}{\omega(\omega + \bar{\omega}_{di})} \simeq \frac{\bar{\omega}_{di}^2}{\omega^2} \left(1 - \frac{\omega_{xi}}{\bar{\omega}_{di}}\right). \quad (33)$$

From (20) the energy integration in (14) is performed, and we obtain

$$K_i = \frac{15 T_e}{4 T_i} \bar{v}_{dthi}^2 \left(1 - \frac{2 u_{yi}}{5 \bar{v}_{dthi}}\right) \left(\frac{k_y^2 \lambda_{0eq}}{\omega^2}\right). \quad (34)$$

In order to know whether the particles are accelerated toward the magnetic equator or toward the ionosphere, we compute an inverse Fourier transform in space and time for the parallel electric field (32). From the expressions (34) of K_i , (6) and (5), we obtain (see Appendix A)

$$\delta E_{\parallel}(L, y, \theta, t) = -e'(\theta) \left[\frac{15 T_e}{4 T_i} \bar{v}_{dthi}^2 \left(1 - \frac{2 u_{yi}}{5 \bar{v}_{dthi}}\right) \right. \\ \left. \cdot \frac{\mu_0 \delta j_m L_c^2 \exp(\gamma t)}{\sqrt{\pi} \Delta^2 \gamma} \left\{ \zeta - \frac{1}{2} Pf \left[\tilde{W}(\zeta) \right] \right. \right. \\ \left. \left. + \zeta^2 Pf \left[W(\zeta) \right] \right\} \right], \quad (35)$$

where Pf denotes the Cauchy principal value, $\tilde{W}(\zeta) = 1/(\sqrt{\pi}) \int_{-\infty}^{\infty} dV \exp(-V^2)/(V - \zeta)$ is the Fried-Conte function, and $\zeta = y/\Delta$. Close to midnight, $\zeta = y/\Delta < 1$, in this limit, the Fried-Conte function can be approximated by $Pf(\tilde{W}(\zeta)) \simeq -2\zeta + O(\zeta^3)$ and we obtain

$$\delta E_{\parallel}(L, y, \theta, t) = -e'(\theta) \left[\frac{15 T_e}{2 T_i} \bar{v}_{dthi}^2 \left(1 - \frac{2 u_{yi}}{5 \bar{v}_{dthi}}\right) \right. \\ \left. \cdot \frac{\mu_0 \delta j_m L_c^2 \exp(\gamma t)}{\sqrt{\pi} \Delta^2 \gamma} \left(\frac{y}{\Delta}\right) \left[1 - \left(\frac{y}{\Delta}\right)^2\right] \right]. \quad (36)$$

In the inverse limit $\zeta > 1$ (far away from the midnight meridian), the expansion of the Fried-Conte function is $-1/\zeta$ and the parallel electric field goes to zero:

$$\delta E_{\parallel}(L, y, \theta, t) = -e'(\theta) \left[\frac{15 T_e}{4 T_i} \bar{v}_{dthi}^2 \left(1 - \frac{2 u_{yi}}{5 \bar{v}_{dthi}}\right) \right. \\ \left. \cdot \frac{\mu_0 \delta j_m L_c^2 \exp(\gamma t)}{\sqrt{\pi} \Delta^2 \gamma} \left(\frac{1}{2\zeta}\right) \right]. \quad (37)$$

From (36), we note that the parallel electric field changes sign between the dawnside and the duskside and is maximum for $y = \pm \Delta/\sqrt{3}$, inside the stretched magnetic field line region $|y| < \Delta/\sqrt{2}$ (see LC00). In the following discussion, we will assume that we are located close to midnight ($\zeta < 1$). We distinguish between two cases: Case A: $|u_y| < \frac{5}{2} |\bar{v}_d|$

$$\delta E_{\parallel} \simeq -\frac{15}{2} e'(\theta) \left[\frac{T_e}{T_i} \bar{v}_{dthi}^2 \right] \\ \cdot \frac{\mu_0 \delta j_m L_c^2 \exp(\gamma t)}{\sqrt{\pi} \Delta^2 \gamma} \left(\frac{y}{\Delta}\right) \left[1 - \left(\frac{y}{\Delta}\right)^2\right]. \quad (38)$$

The parallel electric field is negative (positive), directed toward the equator (toward the ionosphere) in the duskside (in the dawnside). As a consequence, electrons will be accelerated toward the ionosphere in the duskside and toward the equator at the dawnside.

Case B: $|u_y| > \frac{5}{2} |\bar{v}_d|$

$$\delta E_{\parallel} \simeq 3e'(\theta) \left[\frac{T_e}{T_i} \bar{v}_{dthi} u_y \right] \\ \cdot \frac{\mu_0 \delta j_m L_c^2 \exp(\gamma t)}{\sqrt{\pi} \Delta^2 \gamma} \left(\frac{y}{\Delta}\right) \left[1 - \left(\frac{y}{\Delta}\right)^2\right]. \quad (39)$$

In this case, the parallel electric field direction depends on the direction of the pressure gradient. In the magnetic tail where the pressure gradient is directed earthward, electrons are accelerated toward the equator in the duskside and toward the ionosphere in the dawnside. Compared to case A, the situation is reversed. On the other hand, in regions closer to the Earth, where the pressure gradient may be directed toward the tail, each of the above direction is reversed. Case B is presented in Figure 2 where we have taken into account the change of direction of the pressure gradient when we move closer to the Earth. The direction of the expected electron precipitations is summarized in Table 1.

3.3. Large Magnetic Drift Limit ($\bar{\omega}_d > \omega$)

Now, we consider the opposite assumption $\bar{\omega}_d > \omega$, which corresponds to a very low frequency perturbation or to a very large k_y (an highly localized perturbation in longitude). In this limit, the term between brackets of K_i in (14) can be approximated by:

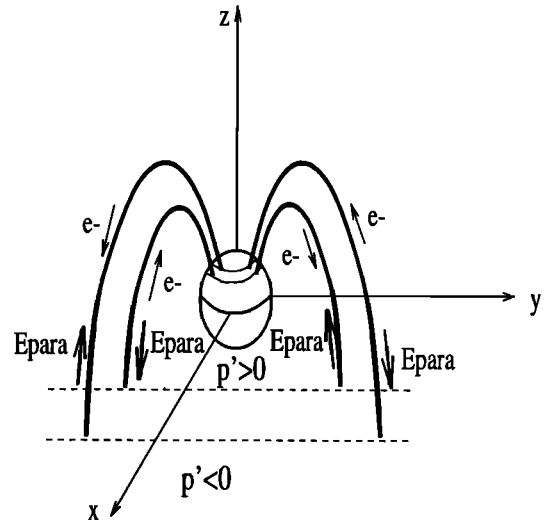

Figure 2. Variation of the direction of the parallel electric field and of the electron precipitations as a function of y and of the pressure gradient (case B). The configuration is symmetrical about the magnetic equator.

Table 1. Table of Electron Precipitations in the Dusk-side ($y < 0$) in the Limit $\bar{\omega}_d < \omega$

	$p' > 0$	$p' < 0$
$\bar{\omega}_d > \omega_*$	$\Rightarrow \mathbf{Io}$	$\Rightarrow \mathbf{Io}$
$\bar{\omega}_d < \omega_*$	$\Rightarrow \mathbf{Io}$	$\Rightarrow \mathbf{Eq}$

$\Rightarrow \mathbf{Eq}$ (Io) means that electrons are accelerated equatorward (toward the ionosphere).

$$\frac{\bar{\omega}_{di}(\bar{\omega}_{di} - \omega_{*i})}{\omega(\omega + \bar{\omega}_{di})} \simeq \frac{\bar{\omega}_{di}}{\omega} \left(1 - \frac{\omega_{*i}}{\bar{\omega}_{di}}\right). \quad (40)$$

Therefore, after an integration on the energy E , the expression (14) of K_i , in the limit $\bar{\omega}_d > \omega$, writes

$$K_i = \frac{3}{2} \frac{T_e}{T_i} \bar{v}_{dthi} \left(1 - \frac{2}{3} \frac{u_{yi}}{\bar{v}_{dthi}}\right) \left(\frac{k_y \lambda_{0eq}}{\omega}\right), \quad (41)$$

which gives for the parallel electric field, after an inverse Fourier transform in space and time (see Appendix A for the method):

$$\delta E_{\parallel}(L, y, \theta, t) = \frac{3}{2} e'(\theta) \frac{T_e}{T_i} \bar{v}_{dthi} \left(1 - \frac{2}{3} \frac{u_{yi}}{\bar{v}_{dthi}}\right) \cdot \frac{\mu_0 \delta j_m L_c^2}{\sqrt{\pi} \Delta} \exp(\gamma t) \left\{1 + \zeta P f [\tilde{W}(\zeta)]\right\}. \quad (42)$$

Close to midnight, $\zeta = y/\Delta < 1$, we obtain

$$\delta E_{\parallel}(L, y, \theta, t) = \frac{3}{2} e'(\theta) \frac{T_e}{T_i} \bar{v}_{dthi} \left(1 - \frac{2}{3} \frac{u_{yi}}{\bar{v}_{dthi}}\right) \cdot \frac{\mu_0 \delta j_m L_c^2}{\sqrt{\pi} \Delta} \exp(\gamma t) \left[1 - 2 \left(\frac{y}{\Delta}\right)^2\right]. \quad (43)$$

In the opposite limit $\zeta > 1$ (far away from the midnight meridian), the expansion of the Fried-Conte function is $-1/\zeta$ and the parallel electric field goes to zero:

$$\delta E_{\parallel}(L, y, \theta, t) \simeq 0. \quad (44)$$

Equation (43) shows that the parallel electric field does not change sign in the region where the magnetic field lines are stretched ($|y| < \Delta/\sqrt{2}$). In the following discussion, we will consider a location close to midnight ($\zeta < 1$). We distinguish again between two cases:

Case C: $|u_y| < \frac{3}{2} |\bar{v}_d|$

$$\delta E_{\parallel} \simeq \frac{3}{2} e'(\theta) \frac{T_e}{T_i} \bar{v}_{dthi} \cdot \frac{\mu_0 \delta j_m L_c^2}{\sqrt{\pi} \Delta} \exp(\gamma t) \left[1 - 2 \left(\frac{y}{\Delta}\right)^2\right]. \quad (45)$$

The parallel electric field is positive around midnight, directed toward the ionosphere. Thus electrons are accelerated toward the equator in the region where the magnetic field lines are more stretched. They are accelerated toward the ionosphere in the morning and evening sectors for $|y| > \Delta/\sqrt{2}$.

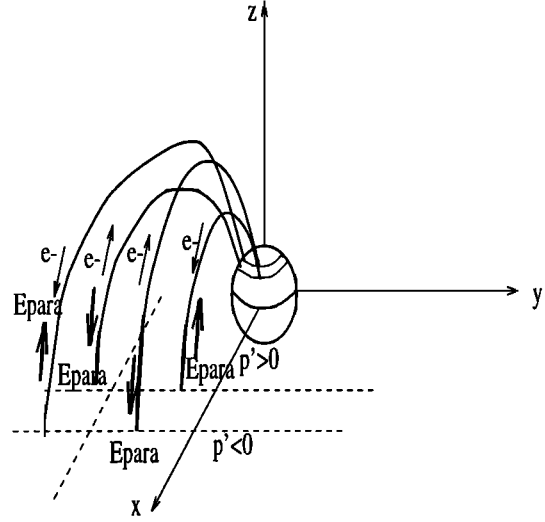

Figure 3. Variations of the direction of the parallel electric field and of the electron precipitations in the dusk-side as a function of the pressure gradient (case D). The dawn-side configuration is obtained by symmetry around the noon/midnight meridian.

Case D: $|u_y| > \frac{3}{2} |\bar{v}_d|$

$$\delta E_{\parallel} \simeq -e'(\theta) \frac{T_e}{T_i} u_{yi} \cdot \frac{\mu_0 \delta j_m L_c^2}{\sqrt{\pi} \Delta} \exp(\gamma t) \left[1 - 2 \left(\frac{y}{\Delta}\right)^2\right]. \quad (46)$$

In this last case, we find again a pressure gradient dependence of the parallel electric field. In the plasma sheet, where the pressure gradient is directed earthward (p' is negative), the parallel electric field is directed toward the equator and the electrons are accelerated toward the ionosphere around midnight. In the flanks the situation is reversed. Closer to the Earth, the pressure may be directed tailward, then all the results are reversed; electrons move toward the ionosphere at midnight and toward the equator in the flanks (Figure 3). The directions of the expected electron motion are summarized in the Table 2.

4. Discussion

The duration of the growth phase is of order 30 min and the ion thermal energy is around 10 keV

Table 2. Table of Electron Precipitations in the Region Around the Noon/Midnight Meridian ($|y| < \Delta/\sqrt{2}$) in the Limit $\bar{\omega}_d > \omega$

	$p' > 0$	$p' < 0$
$\bar{\omega}_d > \omega_*$	$\Rightarrow \mathbf{Eq}$	$\Rightarrow \mathbf{Eq}$
$\bar{\omega}_d < \omega_*$	$\Rightarrow \mathbf{Eq}$	$\Rightarrow \mathbf{Io}$

$\Rightarrow \mathbf{Eq}$ (Io) means that electrons are accelerated equatorward (toward the ionosphere).

in the NEPS. Moreover, dual-satellite studies suggest that the scale length of the perturbation associated with the formation of the current sheet during the growth phase cannot be smaller than one Earth radius. Therefore the assumption $\bar{\omega}_d < \omega$ seems reasonable. Furthermore, from the azimuthal asymmetry of the ion flux (between duskward/dawnward directions) measured aboard a geostationary spacecraft [e.g., *Korth et al.*, 1991], we know that the scale length, L_P , of the ion pressure gradient is relatively small ($L_P \simeq 0.5 - 1 R_E$). Since we have $u_y/\bar{v}_d \simeq L/L_P \simeq 6 - 10$, we can consider that $|u_y| > \frac{5}{2}|\bar{v}_d|$ close to the geosynchronous region. Thus it seems that the most appropriate case for the substorm growth phase is case B, since in this case the particles that ensure the QNC verify $\bar{\omega}_d < \omega$ and $|u_y| > |\bar{v}_d|$. Therefore we expect the parallel electric field to be directed toward the ionosphere in the duskside, whereas it should be directed toward the magnetic equator in the dawnside. As a consequence, cold ionospheric electrons should be accelerated toward the equator at dusk, whereas hot plasma sheet electrons will move toward the ionosphere at dawn. This result is linked to the assumption that the perturbation associated with the magnetic field lines stretching is localized along the y direction. The magnitude of the parallel electric field during the growth phase can be estimated. In (39), we assume (1) the timescale for the growth phase of $\simeq 30$ minutes, (2) the characteristic increase of the radial component of the magnetic field of 30 nT, (3) the radial extent of the current sheet of $1 R_E$, and (4) the forcing current L_c is at $7 R_E$. Remind that the diamagnetic drift velocity is $u_y = p'/(qn_0) \simeq T/(qL_P B_{eq})$ and that the bounce-averaged curvature-gradient magnetic drift velocity is $\bar{v}_{dth} = -2T/(qLB_{eq})$. We use the following parameters: 1 keV for the electron temperature and 10 keV for the ion temperature. The scale, Δ , of the perturbed region is taken to be $4 R_E$, L_P , the scale length of the ion pressure gradient is $2 R_E$, (much larger than values estimated by *Korth et al.* [1991]), then the parallel electric field at the geostationary orbit $L \simeq 6.6 R_E$, given by (39), is $E_{\parallel} \simeq 1.6 \times 10^{-5} \text{Vm}^{-1}$ with $e'(\theta) \simeq 0.1$. A smaller scale for the ion pressure gradient would result in a larger parallel electric field. For a distance between the ionosphere and the magnetic equator equal to $\pi L/2$, we obtain a field-aligned potential drop of a few hundred volts, which is far from negligible. We suggest that this parallel electric field produces a parallel drift velocity between electrons and ions. It has been shown elsewhere that the drifting electrons can generate electromagnetic waves, observed at substorm breakup [*Perraut et al.*, 1993] with frequencies of the order of the proton gyrofrequency ($F_{H^+} \simeq 1 \text{ Hz}$). More recently, *Perraut et al.* [1998] have shown that these waves are produced via a current-driven instability when the parallel drift velocity of electrons with respect to ions is large enough (a fraction of the ion thermal velocity). Since they are able to diffuse spatially the thermal ions and to suppress locally the pressure

gradient, these waves may cause the disruption of the current observed in the near-Earth magnetotail ($7-12 R_E$).

Present results seem to contradict those of *Koskinen* (compare Figure 3 of *Koskinen et al.* [1996] with our Figure 3). But as *Koskinen* pointed out: “the parallel field of Fig. 3 is not the real electric field in the plasma. Due to their high parallel mobility charged particles quickly compensate the parallel component of the slowly evolving inductive field”. In fact, during the growth phase, we have the following ordering $\omega_{be} > \omega_{bi} > \omega$. Thus, the field-aligned potential drop results from the differences between the bounce average responses of electrons and that of ions, due to their different temperature. In the limit $T_e/T_i < 1$, this difference is small and therefore the field-aligned potential is small too. This is why the lowest order of the QNC gives $\delta\Phi + \lambda = \text{const}$, which means that to the lowest order in (T_e/T_i) , the inductive component of the parallel electric field $\partial A_{\parallel}/\partial t = \partial\lambda/\partial t$ is balanced by the electrostatic component $\partial\delta\Phi/\partial t$. Thus the parallel electric field found by *Koskinen et al.* [1996], from a non self-consistent approach, does not develop because the particle response tends to cancel it. Notice that the high parallel mobility, corresponding to large ion and electron temperatures, does not cancel the parallel electric field in a mirror geometry for low-frequency perturbations. In the present paper, we have shown, for the simple case where $T_e < T_i$, that a parallel electric field proportional to T_e/T_i develops. The present study shows the importance of ensuring QNC while imposing magnetic field variations. Finally, we point out that LC00 solved the full Vlasov-Maxwell system of equations only in the quasi-static limit, notably the solution of Ampère’s law is valid only in this limit. However, the results obtained from the lowest order in T_e/T_i of the QNC in LC00 and to the first order in the present paper are basically valid for low-frequency perturbations $\omega < \omega_b$.

Although the above results allow a self-consistent description of the origin of parallel electric fields, there are some limitations that should be stressed. The present calculation has been carried out with the low- β assumption since the 2-D dipole has been used to solve the Ampère’s law with a forcing current in LC00 and to obtain the explicit expression for the parallel electric field in the present paper. This limit is not a priori valid for the plasma sheet, especially for large radial distances. However, even with this restrictive assumption we have taken into account the pressure gradient effect to the lowest order. For higher values of β we expect the general trend to be the same, but another equilibrium should be used which would preclude any analytical approach.

Another limitation is the fact that we do not take into account the ionosphere/magnetosphere coupling. The QNC for the magnetotail plasma is likely to be modified by the presence of the ionospheric plasma. Keeping in

mind the above limitations, the present model provides a self-consistent kinetic description of the generation of parallel electric fields in a mirror geometry for quasi-static perturbations ($\omega < k_{\parallel} v_A$ and $\omega < \omega_b$).

5. Conclusion

The linear response of the plasma to quasi-static perturbations ($\omega < k_{\parallel} v_A$ and $\omega < \omega_b$) has been studied and the full Vlasov-Maxwell system of equations has been solved. In particular, the QNC has been solved via an expansion in the small parameter T_e/T_i . To the lowest order in T_e/T_i , the QNC implies the existence of a new contribution to the perturbed electrostatic potential which modifies the perpendicular transport of the plasma. To the lowest order in T_e/T_i , the parallel electric field can be neglected. To the next order in T_e/T_i , the QNC enables an analytical calculation of the residual field-aligned potential drop proportional to T_e/T_i . Only in the particular case of the substorm growth phase, did we explicitly compute this parallel electric field. Using the solutions of Ampère's law obtained in LC00, we found that in the case where we can assume $\bar{\omega}_d < \omega$ and $|\bar{v}_d| < |u_y|$, a field-aligned potential drop of a few hundred volts develops during the growth phase. The associated parallel electric field is directed toward the ionosphere in the dusk sector and toward the equator in the dawn sector. This parallel electric field is able to produce a parallel drift velocity between electrons and ions. The drifting electrons may generate electromagnetic waves, observed at substorm breakup [Perraut *et al.*, 1993] with frequencies of the order of the proton gyrofrequency ($F_{H^+} \simeq 1$ Hz), via a current-driven instability when the drift velocity exceeds the thermal ion velocity.

Appendix A: Inversion of the Fourier Transform

In this appendix, we do not omit the Fourier notations; therefore we have

$$\widehat{\delta E}_{\parallel}(L, k_y, \theta, \omega) = \frac{1}{L} e'(\theta) \left[\frac{15 T_e}{4 T_i} \bar{v}_{dthi}^2 \cdot \left(1 - \frac{2 u_{yi}}{5 \bar{v}_{dthi}} \right) \right] \frac{k_y^2}{\omega^2} \widehat{\lambda}_{neq}(k_y, \omega), \quad (\text{A1})$$

and the real component δE_{\parallel} writes

$$\delta E_{\parallel}(L, y, \theta, t) = \frac{1}{2\pi} \int_{-\infty}^{+\infty} d\omega \int_{-\infty}^{+\infty} dk_y \delta \widehat{E}_{\parallel}(L, k_y, \theta, \omega) \cdot \exp[i(k_y y + \omega t)] \quad (\text{A2})$$

$$\delta E_{\parallel}(L, y, \theta, t) = \frac{1}{L} e'(\theta) \left[\frac{15 T_e}{4 T_i} \bar{v}_{dthi}^2 \left(1 - \frac{2 u_{yi}}{5 \bar{v}_{dthi}} \right) \right] \cdot \frac{1}{2\pi} \int_{-\infty}^{+\infty} d\omega \int_{-\infty}^{+\infty} dk_y \frac{k_y^2}{\omega^2} \widehat{\lambda}_{neq}(k_y, \omega) \cdot \exp[i(k_y y + \omega t)]. \quad (\text{A3})$$

Using the expression of $\lambda_{neq} = 1/[4(n+1)]\mu_0(|k_y|/k_y) \cdot \omega \delta j_{eq}(k_y, \omega) L_c^2 L$ for $n = 0$, we write

$$\delta E_{\parallel}(L, y, \theta, t) = e'(\theta) \left[\frac{15 T_e}{4 T_i} \bar{v}_{dthi}^2 \left(1 - \frac{2 u_{yi}}{5 \bar{v}_{dthi}} \right) \right] \cdot \frac{L_c^2 \mu_0}{4} \frac{1}{2\pi} \int_{-\infty}^{+\infty} d\omega \int_{-\infty}^{+\infty} dk_y \frac{k_y}{\omega} |k_y| \widehat{\delta j}_{eq}(k_y, \omega) \cdot \exp[i(k_y y + \omega t)]. \quad (\text{A4})$$

The ω integration is straightforward and gives

$$\delta E_{\parallel}(L, y, \theta, t) = e'(\theta) \left[\frac{15 T_e}{4 T_i} \bar{v}_{dthi}^2 \left(1 - \frac{2 u_{yi}}{5 \bar{v}_{dthi}} \right) \right] \cdot \frac{L_c^2 \mu_0}{4} \frac{1}{\sqrt{2\pi}} \int_{-\infty}^{+\infty} dk_y i k_y |k_y| \int dt \widehat{\delta j}_{eq}(k_y, t) \cdot \exp(i k_y y). \quad (\text{A5})$$

For the k_y integration we note that

$$i k_y |k_y| = k_y^2 \text{isign}(k_y) = -\frac{k_y^2}{\pi} FT \left(Pf \left(\frac{1}{y} \right) \right) \quad (\text{A6})$$

$$i k_y |k_y| = \frac{1}{\pi} FT \left\{ \frac{\partial^2}{\partial y^2} \left[Pf \left(\frac{1}{y} \right) \right] \right\}, \quad (\text{A7})$$

where FT denotes a one dimension Fourier transform and Pf the Cauchy principal value. The perturbed magnetic field component becomes

$$\delta E_{\parallel}(L, y, \theta, t) = e'(\theta) \left[\frac{15 T_e}{4 T_i} \bar{v}_{dthi}^2 \left(1 - \frac{2 u_{yi}}{5 \bar{v}_{dthi}} \right) \right] \cdot \frac{L_c^2 \mu_0}{4} \int_{-\infty}^{+\infty} dk_y \left(\frac{1}{\pi} FT \left\{ \frac{\partial^2}{\partial y^2} \left[Pf \left(\frac{1}{y} \right) \right] \right\} \right) \cdot FT \left[\int dt \delta j_{eq}(y, t) \right] \exp(i k_y y). \quad (\text{A8})$$

Moreover, the convolution theorem gives

$$\widehat{f * g} = \widehat{f} \cdot \widehat{g} \iff f * g = FT^{-1} \left(\widehat{f} \cdot \widehat{g} \right). \quad (\text{A9})$$

Therefore we obtain

$$\delta E_{\parallel}(L, y, \theta, t) = e'(\theta) \left[\frac{15 T_e}{4 T_i} \bar{v}_{dthi}^2 \left(1 - \frac{2 u_{yi}}{5 \bar{v}_{dthi}} \right) \right] \cdot \frac{L_c^2 \mu_0}{4\pi} \int_{-\infty}^{+\infty} dy' \left(\int dt \delta j_{eq}(y', t) \right) \cdot Pf \left(\frac{2}{(y - y')^3} \right). \quad (\text{A10})$$

Finally, we can write

$$\delta E_{\parallel}(L, y, \theta, t) = e'(\theta) \left[\frac{15 T_e}{4 T_i} \bar{v}_{dthi}^2 \left(1 - \frac{2 u_{yi}}{5 \bar{v}_{dthi}} \right) \right] \cdot \frac{L_c^2 \mu_0}{2\pi} Pf \left(\int_{-\infty}^{+\infty} dy' \frac{\int dt \delta j_{eq}(y', t)}{(y - y')^3} \right). \quad (\text{A11})$$

Using the expression of $\delta j_{eq}(y, t)$,

$$\delta j_{eq}(y, t) = \delta j_m \exp(-y^2/\Delta^2) \exp \gamma t, \quad (\text{A12})$$

we defined the variables $Y = y'/\Delta$ and $\zeta = y/\Delta$, the parallel electric field becomes

$$\begin{aligned} \delta E_{\parallel}(L, y, \theta, t) = e'(\theta) & \left[\frac{15 T_e}{4 T_i} \bar{v}_{dthi}^2 \left(1 - \frac{2}{5} \frac{u_{yi}}{\bar{v}_{dthi}} \right) \right] \\ & \cdot \frac{L_c^2 \mu_0 \delta j_m}{2\pi \gamma \Delta^2} \exp(\gamma t) \\ & \cdot Pf \left(\int_{-\infty}^{+\infty} dY \frac{\exp(-Y^2/\Delta^2)}{(\zeta - Y)^3} \right), \quad (\text{A13}) \end{aligned}$$

where we have performed the temporal integration. Then, after two integrations by parts, we obtain

$$\begin{aligned} \delta E_{\parallel}(L, y, \theta, t) = -e'(\theta) & \left[\frac{15 T_e}{4 T_i} \bar{v}_{dthi}^2 \left(1 - \frac{2}{5} \frac{u_{yi}}{\bar{v}_{dthi}} \right) \right] \\ & \cdot \frac{\mu_0 \delta j_m}{\sqrt{\pi}} \frac{L_c^2}{\Delta^2} \frac{\exp(\gamma t)}{\gamma} \\ & \cdot Pf \left(\zeta - \frac{\tilde{W}(\zeta)}{2} + \zeta^2 \tilde{W}(\zeta) \right), \quad (\text{A14}) \end{aligned}$$

where $\tilde{W}(\zeta) = 1/(\sqrt{\pi}) \int_{-\infty}^{\infty} dV \exp(-V^2)/(V - \zeta)$ is the Fried-Conte function.

Acknowledgments. We thank G. Belmont and D. Le Quéau for useful discussions. This work was partially supported by University of Versailles St Quentin and by a post-doctoral fellowship funded by CNES.

Michel Blanc thanks Liu Chen and another referee for their assistance in evaluating this paper.

References

- Antonsen, T. M., Jr., and B. Lane, Kinetic equations for low frequency instabilities in inhomogeneous plasmas, *Phys. Fluids*, **23**, 1205, 1980.
- Frank, L. A., W. R. Paterson, K. L. Ackerson, S. Kokubun, and T. Yamamoto, Plasma velocity distributions in the near-Earth plasma sheet: A first look with the Geotail spacecraft, *J. Geophys. Res.*, **101**, 10,627, 1996.
- Huang, T. S., and T. J. Birmingham, Kinetic and thermodynamic properties of a convecting plasma in a two dimensional dipole field, *J. Geophys. Res.*, **99**, 17,295, 1994.
- Hurricane, O. A., R. Pellat, and F. V. Coroniti, The kinetic reponse of a stochastic plasma to low frequency perturbations, *Geophys. Res. Lett.*, **21**, 253, 1994.
- Hurricane, O. A., R. Pellat, and F. V. Coroniti, A new approach to low-frequency "mhd-like" waves in magnetospheric plasmas, *J. Geophys. Res.*, **100**, 19,421, 1995.
- Korth, A., Z. Y. Pu, G. Kremser, and A. Roux, A statistical study of substorm onset conditions at geostationary orbit, in *Magnetospheric Substorms, Geophys. Monogr. Ser.*, edited by J. R. Kan, T. R. Potemra, S. Kokobun, and T. Iijima, vol. 64, p. 343, AGU Washington, D. C., 1991.
- Koskinen, H. E. J., P. K. Toivanen, and T. I. Pulkkinen, Parallel electric fields during the substorm growth phase, in *Third International Conference on Substorms*, edited by E. J. Rolfe and B. Kaldeich, p. 167, ESA, Noordwijk, The Netherlands, 1996.
- Le Contel, O., R. Pellat, and A. Roux, Self-consistent quasi-static radial transport during the substorm growth phase, *J. Geophys. Res.*, this issue.
- McIlwain, C. E., Auroral electron beams near the magnetic equator, in *Physics of the Hot Plasma in the Magnetosphere*, edited by B. Hultqvist and L. Stenflo, p. 91, Plenum, New York, 1975.
- Parks, G. K., C. S. Lin, B. Mauk, S. DeForest, and C. E. McIlwain, Characteristics of magnetospheric particle injection deduced from events observed on august 18, 1974, *J. Geophys. Res.*, **82**, 5208, 1977.
- Pellat, R., O. A. Hurricane, and F. V. Coroniti, Multipole stability revisited, *Phys. Plasmas*, **1**, 3502, 1994.
- Perraut, S., A. Morane, A. Roux, A. Pedersen, R. Schmidt, A. Korth, G. Kremser, B. Aparicio, and R. Pellinen, Characterization of small scale turbulence observed at substorm onsets: Relationship with parallel acceleration of particles, *Adv. Space Res.*, **13**(4), 217, 1993.
- Perraut, S., A. Roux, O. Le Contel, R. Pellat, A. Pedersen, and A. Korth, Evidence for a substorm trigger, in *Fourth International Conference on Substorms*, edited by S. Kokubun and Y. Kamide, p. 349, Kluwer Academic Publishers, Dordrecht, London, Boston, 1998.
- Rosenbluth, M. N., and R. K. Varma, Approximate equations for plasmas in mirror machines, *Nucl. Fusion*, **7**, 33, 1967.
- Rutherford, P. H., and E. A. Frieman, Drift instabilities in general magnetic field configurations, *Phys. Fluids*, **11**, 569, 1968.

O. Le Contel and A. Roux, Centre d'Etude des Environnements Terrestre et Planétaires, 10-12 avenue de l'Europe, F-78140 Vélizy, France. (olivier.lecontel@cetp.ipsl.fr)

R. Pellat, Centre de Physique Théorique, Ecole Polytechnique, F-91128, Palaiseau, France.

(Received June 10, 1998; revised September 3, 1999; accepted November 30, 1999.)