



**HAL**  
open science

# An hyper-exponential decomposition method for the analysis of productions lines with unreliable machines and finite buffers

Hervé Le Bihan, Yves Dallery

► **To cite this version:**

Hervé Le Bihan, Yves Dallery. An hyper-exponential decomposition method for the analysis of productions lines with unreliable machines and finite buffers. [Research Report] lip6.1997.022, LIP6. 1997. hal-02547640

**HAL Id: hal-02547640**

**<https://hal.science/hal-02547640>**

Submitted on 20 Apr 2020

**HAL** is a multi-disciplinary open access archive for the deposit and dissemination of scientific research documents, whether they are published or not. The documents may come from teaching and research institutions in France or abroad, or from public or private research centers.

L'archive ouverte pluridisciplinaire **HAL**, est destinée au dépôt et à la diffusion de documents scientifiques de niveau recherche, publiés ou non, émanant des établissements d'enseignement et de recherche français ou étrangers, des laboratoires publics ou privés.

# AN HYPER-EXPONENTIAL DECOMPOSITION METHOD FOR THE ANALYSIS OF PRODUCTION LINES WITH UNRELIABLE MACHINES AND FINITE BUFFERS

Hervé LE BIHAN and Yves DALLERY

LIP6 (Laboratoire d'Informatique de Paris 6)  
Université Pierre et Marie Curie  
4 Place Jussieu, 75252 Paris Cedex 05  
FRANCE

Herve.Lebihan@lip6.fr  
Yves.Dallery@lip6.fr

## Abstract

We consider production lines consisting of a series of machines separated by finite buffers. The processing time of each machine is deterministic and all the machines have the same processing time. All machines are subject to failures. As usually the case for production systems we assume that the failures are operation dependent [3,7]. Moreover, we assume that the times to failure and the times to repair are exponentially distributed. To analyze such systems, a decomposition method was proposed by Gershwin [11]. The computational efficiency of this method was later significantly improved by the introduction of the so-called DDX algorithm [5,6]. In general, this method provides fairly accurate results. There are however cases for which the accuracy of this decomposition method may not be so good. This is the case when the reliability parameters (average failure time and average repair time) of the different machines have different orders of magnitude. Such a situation may be encountered in real production lines. In [8] an improvement of Gershwin's original decomposition method has been proposed that in general provides more accurate results in the above mentioned situation. This other method is referred to as the GE-method. The basic difference between the GE-method with that of Gershwin is that it uses a two-moment approximation instead of a one-moment approximation of the repair time distributions of the equivalent machines. There are however still cases for which the accuracy of the GE-method is not as good as expected. This is the case for example when the buffer sizes are too small in comparison with the average repair time. We present in this paper a new decomposition method that is based on a better approximation of the repair time distributions. This method uses a three-moment approximation of the repair time distributions of the equivalent machines. Numerical results show that the new method is very robust in the sense that it seems to provide accurate results in all situations.

*Keywords: production lines, unreliable machines, finite buffers, decomposition method, hyper-exponential distributions*

## 1. Introduction

In this paper, we consider production lines consisting of a series of machines separated by finite buffers. The processing time of each machine is deterministic, i.e., a fixed amount of time is required to perform the operation. Moreover, we assume that all the machines have the same processing time, that is we restrict our attention to so-called *homogeneous lines* [6]. All machines are subject to failures. As is usually the case for production systems we assume that the failures are operation dependent [3,7]. This means that a machine can fail only while it is working. Moreover, we assume that the times to failure and the times to repair are exponentially distributed. Finally, we assume that there are always raw parts available at the input and that there is always room to accommodate the finished parts at the output. Models of production lines with deterministic processing times and exponentially distributed times to failure and times to repair are referred to as *asynchronous models* [7].

A number of methods have been developed for analyzing production lines with unreliable machines and finite buffers (also called transfer lines). See [7] for a survey and a list of references. Obtaining exact analytical solutions of asynchronous models of production lines is in general not feasible. As a result, different models have been used to approximate the behavior of asynchronous models [7]: the synchronous model [2] and the continuous flow model [17]. These models provide a good approximation of the original asynchronous model as long as the average times to failures are significantly larger than the processing times, which is usually the case in production systems [1]. For both models, exact solutions of a line consisting of two machines separated by a finite buffer can be obtained; see e.g. [3,13] in the case of the synchronous model and [9,11] in the case of the continuous flow model.

The analysis of longer lines is based on approximation methods [7]. Among these methods, the decomposition method proposed by Gershwin [11] in the context of the synchronous model appears to be quite accurate. Moreover, using the iterative algorithm proposed in [5], this method can be made very efficient and reliable. A similar decomposition method was proposed in the case of the continuous flow model [6]. However, there are situations for which the accuracy of this decomposition method may not be so good. This is the case when the reliability parameters (average failure time and average repair time) of the different machines have different order of magnitudes. Such a situation may be encountered in real production lines.

In [8] an improvement of Gershwin's original decomposition method was proposed that in general provides accurate results even in the above mentioned situation. This other method is referred to as the GE-method. The basic difference between the GE-method with that of Gershwin is that it uses a two-moment approximation instead of a one-moment approximation of the repair time distributions of the equivalent machines. The repair time distributions of the equivalent machines are approximated by generalized exponential (GE) distributions, which can easily be handled in the decomposition method without involving any additional complexity with respect to the exponential approximation used by Gershwin.[4,8]. Even though the GE-method is fairly robust, there are still situations for which the accuracy is not satisfactory. This is the case for example when the buffer sizes are too small in comparison with the average repair time. We present in this paper a new decomposition method that is based on a better approximation of the repair time distribution. This method is again an extension of Gershwin's decomposition method. The main feature of the new method is that the repair time distributions of the equivalent machines are approximated by two-stage

Hyper-Exponential (HE) distributions. The HE-method uses a three-moment approximation of the repair time distributions. In this paper, we compare the performance results obtained by using the HE-method with those obtained by using a simulation. We also compare the accuracy of the new method with that of Gershwin's original method, referred to as the exponential method (E-method), as well as that of the GE-method proposed in [8]. It appears that the HE-method is very robust in terms of accuracy.

The paper is organized as follows. The continuous flow model is presented in Section 2. The HE decomposition method is described in Section 3. The HE-DDX computational algorithm is given in Section 4. Finally, numerical examples are reported in Section 5.

## 2. The Continuous Flow Model

We consider the continuous flow model of a production line consisting of a series of  $K$  machines ( $M_1, M_2, \dots, M_K$ ) separated by  $K-1$  intermediate buffers ( $B_1, B_2, \dots, B_{K-1}$ ). Parts flow from outside the system to machine  $M_1$ , then to buffer  $B_1$ , then to machine  $M_2$ , and so forth until they reach machine  $M_K$ , after which they leave the system. We assume that there are always parts available at the input of the system and space available at the output of the system. The intermediate buffers are each of finite capacity ( $C_1, C_2, \dots, C_{K-1}$ ). A four machine production line is shown in Figure 1.

The quantity of material in each buffer  $B_i$  at any time is a real number  $h_i(t)$ , where  $0 \leq h_i(t) \leq C_i$ . Each machine can be in two states: operational (not in a failure condition) or down (under repair). When operational, it can be either working or idle. A machine is idle if it is starved or blocked. Machine  $M_i$  is starved at time  $t$  if one of the upstream machines is down and all buffers between this machine and machine  $M_i$  are empty. Machine  $M_i$  is blocked if one of the downstream machines is down and all the buffers in between this machine and machine  $M_i$  are full. A machine that is operational and neither starved nor blocked is working. When machine  $M_i$  is working, it transfers material from its upstream buffer,  $B_{i-1}$ , to its downstream buffer,  $B_i$ , at a constant rate  $U$ . That is a quantity of material  $Udt$  is transferred in time  $dt$ . Note that  $U=1/T$ , where  $T$  is the processing time of all the machines in the original asynchronous model. A machine may fail only while it is working. The time to failure and the time to repair of machine  $M_i$  are exponentially distributed with rates  $\lambda_i$  and  $\mu_i$ , respectively.

Throughout the rest of the paper we assume that  $T = 1$  and that, as a result  $U = 1$ . This is without loss of generality since the time unit can always be chosen so that this condition is satisfied. Let  $L$  denote the continuous flow model of the production line. Let us define the following performance parameters of the continuous model:

$e_i$ : Isolated efficiency of machine  $M_i$ .

$$e_i = \frac{\mu_i}{\lambda_i + \mu_i} = \frac{1}{1 + \frac{\lambda_i}{\mu_i}}$$

$E_i$ : Efficiency of machine  $M_i$ ; proportion of time machine  $M_i$  is working in line  $L$ .

$ps_i$ : Probability of machine  $M_i$  being starved in line  $L$ .

$pb_i$ : Probability of machine  $M_i$  being blocked in line  $L$ .

Since  $U = 1$ ,  $E_i$  can equivalently be interpreted as the production rate of machine  $M_i$  in line  $L$ . The following relationships have been established in [6] for the continuous flow model of tandem production lines.

$$E_1 = E_2 = \dots = E_K \quad (1)$$

$$E_i = e_i (1 - ps_i - pb_i) \quad i = 1, \dots, K \quad (2)$$

The first relation is related to conservation of flow. The second equation relates the efficiency of machine  $M_i$  in line  $L$ ,  $E_i$ , to its efficiency when considered in isolation  $e_i$ . It is an exact relationship in the case of the continuous flow model because a machine cannot be simultaneously starved and blocked [6].

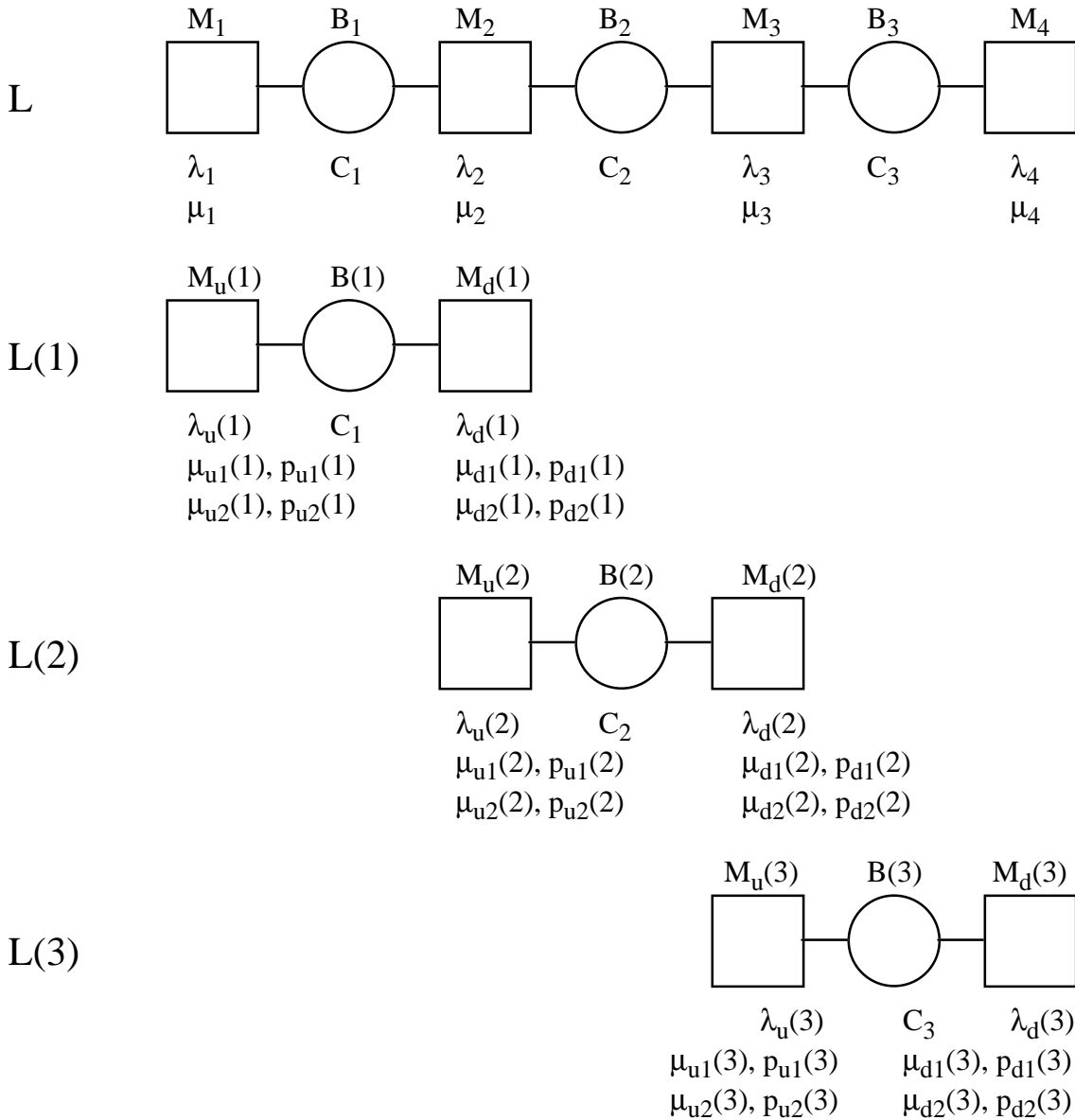

Figure 1: A four-machine production line and its decomposition into three two-machine production lines.

### 3. Decomposition Method

In this section we present the two-stage hyper-exponential decomposition method for the analysis of the continuous flow model. The principle of this method is to decompose the  $K$ -machine line into a set of  $K-1$  two-machine lines  $L(i)$ , for  $i = 1, \dots, K-1$  (see Figure 1). Each line  $L(i)$  is a continuous flow model consisting of an upstream machine  $M_u(i)$ , a downstream machine,  $M_d(i)$ , and an intermediate buffer,  $B(i)$ . There is an infinite supply of material in front of machine  $M_u(i)$ , i.e,  $M_u(i)$  is never starved, while there is an infinite amount of storage available at the output of machine  $M_d(i)$ , i.e,  $M_d(i)$  is never blocked. Each system  $L(i)$  must be defined in such a way that the behavior of the material flow in buffer  $B(i)$  closely matches that of the material flow in buffer  $B_i$  of line  $L$ . Machine  $M_u(i)$  represents (in an aggregate way) the part of the line upstream of buffer  $B_i$ , while machine  $M_d(i)$  represents (in an aggregate way) the part of the line downstream of buffer  $B_i$  (upstream and downstream refer to the direction of the flow of material). In other words, machine  $M_u(i)$  models how material is transferred into buffer  $B_i$ , while machine  $M_d(i)$  models how material is transferred out of buffer  $B_i$ .

To achieve the above goal, the equivalent machines  $M_u(i)$  and  $M_d(i)$  of each line  $L(i)$  are characterized as follows. Both machines have the same processing rate as the machines of line  $L$ , that is  $U = 1$ . The capacity of buffer  $B(i)$  is the same as that of buffer  $B_i$ , that is  $C_i$ . The failure times of machine  $M_u(i)$  and  $M_d(i)$  have exponential distributions with parameters  $\lambda_u(i)$  and  $\lambda_d(i)$ , respectively. So far, this is totally similar to Gershwin's approach. As stated in the introduction, the difference between the method proposed in this paper and that of Gershwin lies in the characterization of the repair time distributions. Let us recall that in Gershwin's method, the repair time distributions of the equivalent machines are assumed to be exponential.

In order to define the characterization of the repair time distributions, consider for instance the failure/repair mechanism of machine  $M_u(i)$ . A failure of machine  $M_u(i)$  represents either a failure or a starvation of machine  $M_i$ . A starvation of machine  $M_i$  is a consequence of either a failure or a starvation of machine  $M_{i-1}$ . A starvation of machine  $M_{i-1}$  is in turn a consequence of either a failure or a starvation of machine  $M_{i-2}$ , and so forth. Thus, a failure of Machine  $M_u(i)$  is caused either by a failure of machine  $M_i$  or by a failure of one of the upstream machines ( $M_{i-1}, \dots, M_1$ ). As a result, the repair of Machine  $M_u(i)$  will be the consequence of a repair of machine  $M_i$ , in case machine  $M_i$  is down, or of a residual repair time of one of the upstream machines ( $M_{i-1}, \dots, M_1$ ) at the instant of starvation, in case machine  $M_i$  is starved. Now, since the repair time of every machine  $j$ ,  $j = i-1, \dots, 1$ , is exponentially distributed, its residual repair time is also exponentially distributed with the same rate  $\mu_j$ . Thus, we conclude that the repair time of machine  $M_u(i)$  should be characterized by an so-called hyper-exponential distribution (i.e., a probabilistic mixture of exponential distributions) consisting of  $i$  stages, with rates  $\mu_i, \mu_{i-1}, \dots, \mu_1$ , as shown in figure 2. Similarly, the repair time of machine  $M_d(i)$  should be characterized by an hyper-exponential distribution consisting of  $K-i$  stages, with rates  $\mu_{i+1}, \mu_{i+2}, \dots, \mu_K$ .

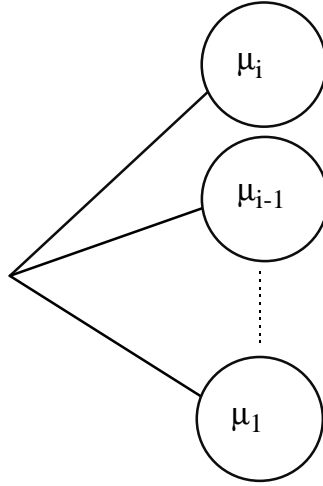

Figure 2: Illustration of the repair time distribution of Machine  $M_u(i)$ .

Before going any further, one important question arises pertaining to the analysis of each subsystem  $L(i)$ . Indeed, in any decomposition method, the overall method relies on the analysis of each subsystem  $L(i)$ . If this analysis is too complex, then the decomposition method may become too cumbersome and not suitable for solving large production lines. It turns out that this may be the case if we are directly using the above characterization. Indeed, the analysis of line  $L(i)$  would imply solving the continuous flow model of a two-machine subsystem with exponential failure time distributions and hyper-exponential repair time distributions with  $i$  and  $K-i$  stages for the upstream and downstream machines, respectively. This would involve solving a set of  $K-1$  differential equations, which is very tedious, if not impossible [15].

To reduce the complexity, while retaining the idea of this new characterization, we propose to replace the characterization of the repair time distributions using hyper-exponential distributions with arbitrary number of stages by a characterization using hyper-exponential distributions consisting of only two stages. The idea behind this simplification, is that an arbitrary hyper-exponential distribution can always be approximated by a two-stage hyper-exponential distribution having the same first three moments (see Appendix B). Now, it turns out with this characterization, the analysis of line  $L(i)$  implies solving the continuous flow model of a two-machine subsystem with exponential failure time distributions and two-stage hyper-exponential repair time distributions. This reduces to solving a set of 3 differential equations, which can easily be done (a brief discussion of the solution is given in Appendix A and details can be found in [16]).

Thus, we assume that repair time distribution of machine  $M_u(i)$  is characterized by a two-stage hyper-exponential distribution with parameters  $(\mu_{u1}(i), \mu_{u2}(i), p_{u1}(i), p_{u2}(i))$  (see Figure 3). This means that, with a probability  $p_{u1}(i)$  the repair time is exponentially distributed with rate  $\mu_{u1}(i)$ , while with a probability  $p_{u2}(i)$ , it is exponentially distributed with rate  $\mu_{u2}(i)$ , where  $p_{u1}(i)$  and  $p_{u2}(i)$  verify the following relationships:

$$p_{u1}(i) + p_{u2}(i) = 1 \quad (3)$$

Similarly, we assume that the repair time distribution of machine  $M_d(i)$  is characterized by a two-stage hyper-exponential distribution with parameters  $(\mu_{d1}(i), \mu_{d2}(i), p_{d1}(i), p_{d2}(i))$ . This means that, with a probability  $p_{d1}(i)$  the repair time is exponentially distributed with rate  $\mu_{d1}(i)$ , while with a probability  $p_{d2}(i)$ , it is exponentially distributed with rate  $\mu_{d2}(i)$ , where  $p_{d1}(i)$  and  $p_{d2}(i)$  verify the following relationships:

$$p_{d1}(i) + p_{d2}(i) = 1 \quad (4)$$

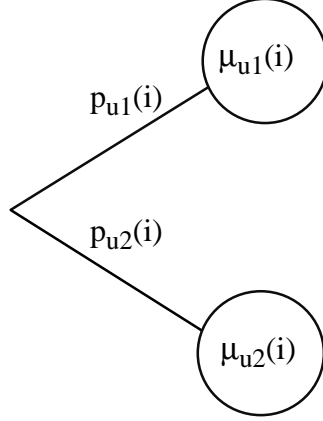

Figure 3: Illustration of the two-stage hyper-exponential approximation of the repair time distribution of machine  $M_u(i)$ .

It is then expected that using a three moment approximation of the repair time distributions of the equivalent machines will lead to a better accuracy of the decomposition method compared to previous methods: Gershwin's method [6,11] that uses a first moment approximation of the repair time distributions and the GE-method [8] that uses a two moment approximation.

In order to determine the unknown parameters  $\lambda_u(i), \mu_{u1}(i), \mu_{u2}(i), p_{u1}(i), p_{u2}(i), \lambda_d(i), \mu_{d1}(i), \mu_{d2}(i), p_{d1}(i)$  and  $p_{d2}(i)$ , for each two-machine line  $L(i), i=1, \dots, K-1$ , we need a set of  $10(K-1)$  independent equations. Since  $p_{u1}(i)$  and  $p_{u2}(i)$  (respectively  $p_{d1}(i)$  and  $p_{d2}(i)$ ) are related through equation (3) (respectively (4)), we actually only need an additional set of  $8(K-1)$  independent equations. In the sequel of this section we derive these equations.

Let us define the following quantities:

$$e_u(i) = \frac{1}{1 + \lambda_u(i) \left( \frac{p_{u1}(i)}{\mu_{u1}(i)} + \frac{p_{u2}(i)}{\mu_{u2}(i)} \right)} \quad i = 1, \dots, K-1 \quad (5)$$

$$e_d(i) = \frac{1}{1 + \lambda_d(i) \left( \frac{p_{d1}(i)}{\mu_{d1}(i)} + \frac{p_{d2}(i)}{\mu_{d2}(i)} \right)} \quad i = 1, \dots, K-1 \quad (6)$$

$e_u(i)$  and  $e_d(i)$  represent the efficiencies of machines  $M_u(i)$  and  $M_d(i)$  in isolation. For each line  $L(i)$ , we define the following performance parameters:



- $E(i)$ : Efficiency of line  $L(i)$ . This is the proportion of time machine  $M_d(i)$  is working.  
 $p_s(i)$ : Probability of machine  $M_d(i)$  being starved in line  $L(i)$ .  
 $p_b(i)$ : Probability of machine  $M_u(i)$  being blocked in line  $L(i)$ .

Again since  $U = 1$ ,  $E(i)$  can equivalently be interpreted as the production rate of line  $L(i)$ . These performance parameters are functions of the parameters of the upstream and downstream machines of  $L(i)$ . We have the following relationships [7]:

$$E(i) = e_u(i)(1 - p_b(i)) \quad i = 1, \dots, K-1 \quad (7)$$

$$E(i) = e_d(i)(1 - p_s(i)) \quad i = 1, \dots, K-1 \quad (8)$$

From equation (1) and (2) and the above conditions the following set of equations can be derived (see [6,7] for details):

$$E(1) = E(2) = \dots = E(K-1) \quad (9)$$

$$E(i-1) = e_i(1 - p_s(i-1) - p_b(i)) \quad i = 2, \dots, K-1 \quad (10)$$

Now using (7), (8) and (9), after some manipulation, (10) can be written as:

$$\frac{1}{e_d(i-1)} + \frac{1}{e_u(i)} = \frac{1}{E(i-1)} + \frac{1}{e_i} \quad i = 2, \dots, K-1 \quad (11)$$

Consider again the failure/repair mechanism of machine  $M_u(i)$ . As discussed above, a failure of machine  $M_u(i)$  represents either a failure or a starvation of machine  $M_i$ . A starvation of machine  $M_i$  is a consequence of either a failure or a starvation of machine  $M_{i-1}$ . In the decomposition, a failure or a starvation of machine  $M_{i-1}$  is represented by a failure of machine  $M_u(i-1)$ . Therefore, a failure of machine  $M_u(i)$  results from either a failure of machine  $M_i$  or a failure of machine  $M_u(i-1)$ . Let  $\alpha_u(i)$  be the proportion of time the cause of the failure of machine  $M_u(i)$  is a failure of machine  $M_u(i-1)$ . As a result, the repair time of machine  $M_u(i)$  is either the repair time of machine  $M_i$ , or the residual repair time of machine  $M_u(i-1)$  at the instant of starvation of machine  $M_i$ . Thus, the repair time distribution of machine  $M_u(i)$  is a probabilistic mixture of the residual repair time distribution of machine  $M_u(i-1)$  (with probability  $\alpha_u(i)$ ) and of the repair time distribution of machine  $M_i$  (with probability  $1 - \alpha_u(i)$ ). Since we assume that the repair time of Machine  $M_u(i-1)$  has a two-stage hyper-exponential distribution and because of using the memoryless property of exponential distributions, it follows that the repair time distribution of machine  $M_u(i-1)$  at the instant of starvation of Machine  $M_i$  is also a two-stage hyper-exponential distribution with rates  $\mu_{u1}(i-1)$  and  $\mu_{u2}(i-1)$ . Let  $p_{u1}^r(i-1)$  (respectively  $p_{u2}^r(i-1)$ ) be the probability that the repair time of Machine  $M_u(i-1)$  at the time of starvation of Machine  $M_i$  is exponentially distributed with rate  $\mu_{u1}(i-1)$  (respectively  $\mu_{u2}(i-1)$ ). As a result, the repair time distribution of machine  $M_u(i)$  is a three-stage hyper-exponential distribution with probabilities  $1 - \alpha_u(i)$ ,  $\alpha_u(i) p_{u1}^r(i-1)$  and  $\alpha_u(i) p_{u2}^r(i-1)$  corresponding respectively to the rates  $\mu_i$ ,  $\mu_{u1}(i-1)$ , and  $\mu_{u2}(i-1)$  respectively (see figure 4).

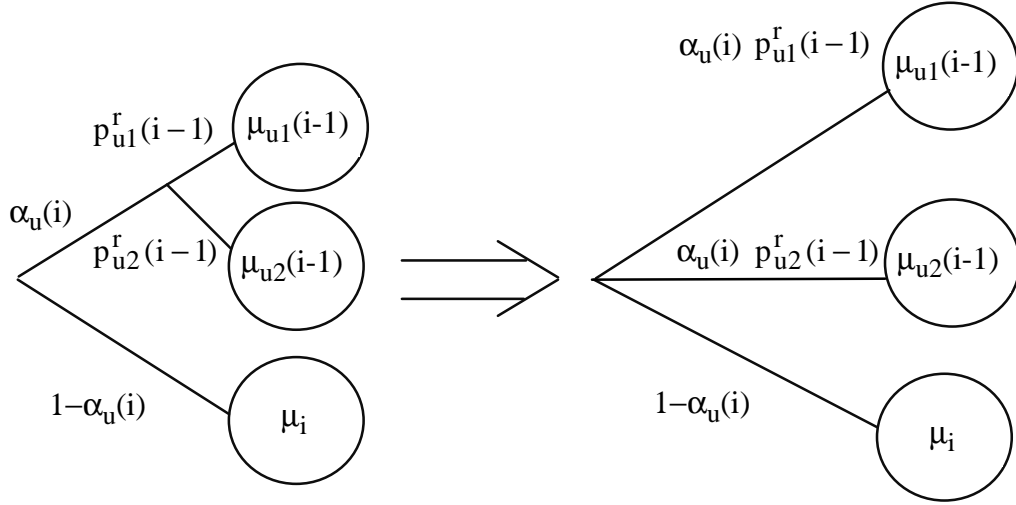

Figure 4: Illustration of the construction of the repair time distribution of machine  $M_u(i)$ .

Let us now calculate the quantity  $\alpha_u(i)$ .  $\alpha_u(i)$  is the ratio of the average number of failures (per unit of time) of machine  $M_u(i)$  which result from a failure of machine  $M_u(i-1)$  to the average number of failures (per unit of time) of machine  $M_u(i)$ . Let  $m_u^{(1)}(i)$  be the average repair time of machine  $M_u(i)$ . Let  $D_u(i)$  be the probability of machine  $M_u(i)$  being in a failure condition. Then, the average number of failures (per unit of time) occurring on machine  $M_u(i)$ , which is equal to that of repairs, is equal to  $D_u(i) / m_u^{(1)}(i)$ . On the other hand, the probability of machine  $M_u(i)$  being in a failure condition which is a consequence of a failure of machine  $M_u(i-1)$ , is equal to  $p_s(i-1)$ . Let  $m_u^r(i-1)$  be the average residual repair time of machine  $M_u(i-1)$  at the instant of starvation of machine  $M_u(i)$ . Then, the average number of failures (per unit of time) of  $M_u(i)$  that result from a failure of machine  $M_u(i-1)$ , which is equal to that of repairs, is equal to  $p_s(i-1) / m_u^r(i-1)$ . As a result the quantity  $\alpha_u(i)$  is given by:

$$\alpha_u(i) = \frac{p_s(i-1)m_u^{(1)}(i)}{D_u(i)m_u^r(i-1)} \quad i = 2, \dots, K-1 \quad (12)$$

The probability of machine  $M_u(i)$  being in failure condition,  $D_u(i)$ , can be expressed as (see Property 1 in the Appendix of [7]):

$$D_u(i) = \left( \frac{1}{e_u(i)} - 1 \right) E(i) \quad i = 1, \dots, K-1 \quad (13)$$

By definition, the quantity  $m_u^{(1)}(i)$  is given by:

$$m_u^{(1)}(i) = \alpha_u(i)m_u^r(i-1) + (1 - \alpha_u(i))m_i^{(1)} \quad i = 2, \dots, K-1 \quad (14)$$

where  $m_i^{(1)}$  the average repair time of machine  $M_i$  is given by  $m_i^{(1)} = \frac{1}{\mu_i}$  and  $m_u^r(i-1)$ , the average residual repair time of machine  $M_u(i-1)$  at the instant of starvation is given by:

$$m_u^r(i-1) = \frac{p_{u1}^r(i-1)}{\mu_{u1}(i-1)} + \frac{p_{u2}^r(i-1)}{\mu_{u2}(i-1)} \quad i = 2, \dots, K-1 \quad (15)$$

As a result, using (15), (14) can be written as:

$$m_u^{(1)}(i) = \alpha_u(i) \left[ \frac{p_{u1}^r(i-1)}{\mu_{u1}(i-1)} + \frac{p_{u2}^r(i-1)}{\mu_{u2}(i-1)} \right] + \frac{1 - \alpha_u(i)}{\mu_i} \quad i = 1, \dots, K-1 \quad (16)$$

Using (13), (15), and (16),  $\alpha_u(i)$  can finally be expressed as:

$$\alpha_u(i) = \frac{1}{\mu_i \left( \frac{\left( \frac{1}{e_u(i)} - 1 \right) E(i-1)}{p_s(i-1)} - 1 \right) \left( \frac{p_{u1}^r(i-1)}{\mu_{u1}(i-1)} + \frac{p_{u2}^r(i-1)}{\mu_{u2}(i-1)} \right) + 1}$$

We have thus obtained a first representation of the repair time distribution of  $M_u(i)$  as a three-stage hyper-exponential distribution. However we have assumed a two-stage hyper-exponential distribution as the characterization of this repair time distribution of machine  $M_u(i)$ . In order to obtain this distribution, we approximate the three-stage HE distribution by a two-stage HE distribution, using a three moment approximation, as illustrated in Figure 5. As shown in Appendix B, for any three-stage HE distribution, there exists a two-stage HE distribution having the same first three moments.

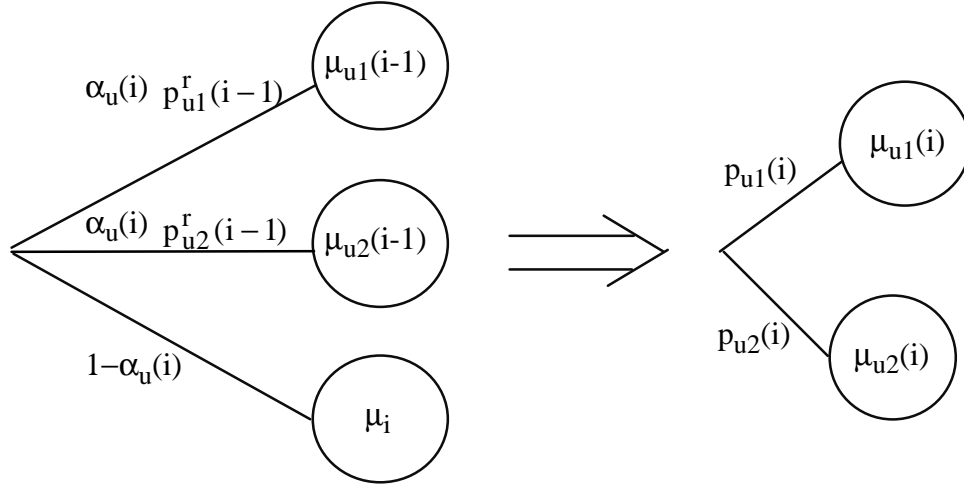

Figure 5: Illustration of the three moment approximation of the three-stage hyper-exponential repair time distribution of machine  $M_u(i)$  by a two-stage HE-distribution.

Let  $m_u^{(1)}(i)$ ,  $m_u^{(2)}(i)$  and  $m_u^{(3)}(i)$  be the first, second and third moments of the original three-stage hyper-exponential distribution. They can be calculated using the following expressions:

$$m_u^{(1)}(i) = \frac{\alpha_u(i)p_{u1}^r(i-1)}{\mu_{u1}(i-1)} + \frac{\alpha_u(i)p_{u2}^r(i-1)}{\mu_{u2}(i-1)} + \frac{1-\alpha_u(i)}{\mu_i}$$

$$m_u^{(2)}(i) = \frac{2\alpha_u(i)p_{u1}^r(i-1)}{\mu_{u1}(i-1)^2} + \frac{2\alpha_u(i)p_{u2}^r(i-1)}{\mu_{u2}(i-1)^2} + \frac{2(1-\alpha_u(i))}{\mu_i^2}$$

$$m_u^{(3)}(i) = \frac{6\alpha_u(i)p_{u1}^r(i-1)}{\mu_{u1}(i-1)^3} + \frac{6\alpha_u(i)p_{u2}^r(i-1)}{\mu_{u2}(i-1)^3} + \frac{6(1-\alpha_u(i))}{\mu_i^3}$$

From the three first moments of the three-stage hyper-exponential distribution we can derive the parameters,  $p_{u1}(i)$ ,  $p_{u2}(i)$ ,  $\mu_{u1}(i)$  and  $\mu_{u2}(i)$  of the two-stage hyper-exponential distribution by means of the equations given in Appendix B.

A totally similar analysis of the failure-repair mechanism of Machine  $M_d(i)$  can be developed. First the repair time distribution of machine  $M_d(i)$  can be represented as a three-stage hyper-exponential distribution (see figure 5). The quantity  $\alpha_d(i)$  denotes the proportion of time a failure of machine  $M_d(i)$  is caused by a failure of machine  $M_d(i+1)$ . It can be expressed as:

$$\alpha_d(i) = \frac{p_b(i+1)m_d^{(1)}(i)}{D_d(i)m_d^r(i+1)}$$

Following derivations similar to those used for  $\alpha_u(i)$ ,  $\alpha_d(i)$  can finally be expressed as:

$$\alpha_d(i) = \frac{1}{\mu_{i+1} \left( \frac{\left( \frac{1}{e_d(i)} - 1 \right) E(i+1)}{p_b(i+1)} - 1 \right) \left( \frac{p_{d1}^r(i+1)}{\mu_{d1}(i+1)} + \frac{p_{d2}^r(i+1)}{\mu_{d2}(i+1)} \right) + 1}$$

Finally, there are boundary conditions:

$$\lambda_u(1) = \lambda_1; \mu_{u1}(1) = \mu_1; \mu_{u2}(1) = \mu_1; p_{u1}(1) = 1; p_{u2}(1) = 0; \quad (17)$$

$$\lambda_d(K-1) = \lambda_K; \mu_{d1}(K-1) = \mu_K; \mu_{d2}(K-1) = \mu_K; p_{d1}(K-1) = 1; p_{d2}(K-1) = 0; \quad (18)$$

These boundary conditions simply express the fact that machine  $M_u(i)$  should be exactly identical to machine  $M_1$ , while machine  $M_d(K-1)$  should be exactly identical to machine  $M_K$ .

#### 4. Computational Algorithm

In this section, we propose a general algorithm to determine the unknown parameters of the decomposition method, which is the generalization of the DDX algorithm [5,6]. First of all, it is important to recognize that it is possible to obtain the exact analysis of a two-machine production line model with failure and repair time distributions characterized by exponential and two-stage HE distributions, respectively (a brief discussion of the solution is given in Appendix A and details can be found in [16]). This implies that for given values of the parameters  $\lambda_u(i)$ ,  $\mu_{u1}(i)$ ,  $\mu_{u2}(i)$ ,  $p_{u1}(i)$ ,  $p_{u2}(i)$ ,  $\lambda_d(i)$ ,  $\mu_{d1}(i)$ ,  $p_{d1}(i)$  and  $p_{d2}(i)$  of line  $L(i)$ , the parameters of interest,  $E(i)$ ,  $p_s(i)$ ,  $p_b(i)$ ,  $p_{u1}^r(i)$ ,  $p_{u2}^r(i)$ ,  $p_{d1}^r(i)$  and  $p_{d2}^r(i)$  can easily be derived. With equations derived in section 3, the parameters of the upstream machine  $M_u(i)$  of line  $L(i)$  can be obtained from the performance parameters of line  $L(i-1)$ . Similarly, the parameters of the downstream machine of line  $L(i)$  can be obtained from the performance parameters of line  $L(i+1)$ .

In order to obtain the final computational algorithm, let us transform the original set of equations. After some manipulation, the  $2(K-2)$  equations given by (9) and (11) can be equivalently transformed into the following equations (see [8]):

$$\frac{1}{e_u(i)} = \frac{1}{E(i-1)} + \frac{1}{e_i} - \frac{1}{e_d(i-1)} \quad i = 2, \dots, K-1 \quad (19)$$

$$\frac{1}{e_d(i)} = \frac{1}{E(i+1)} + \frac{1}{e_{i+1}} - \frac{1}{e_u(i+1)} \quad i = 1, \dots, K-2 \quad (20)$$

The following iterative algorithm can be used to determine the unknown parameters of the upstream and downstream machines of all the lines  $L(i)$ ,  $i=1, \dots, K-1$ . As all DDX-type algorithms, it consists of a forward path (step 2) that calculate updated estimates of the parameters of the upstream machines, and a backward path (step 3) that calculate updated estimates of the parameters of the downstream machines.

### Algorithm

#### Step 1. Set:

$$\begin{aligned} \lambda_u(1) &= \lambda_1; \mu_{u1}(1) = \mu_1; \mu_{u2}(1) = \mu_1; p_{u1}(1) = 1; p_{u2}(1) = 0; \\ \lambda_d(K-1) &= \lambda_K; \mu_{d1}(K-1) = \mu_K; \mu_{d2}(K-1) = \mu_K; p_{d1}(K-1) = 1; p_{d2}(K-1) = 0; \\ \text{Initialize} \\ \lambda_d(i) &= \lambda_{i+1}; \mu_{d1}(i) = \mu_{i+1}; \mu_{d2}(i) = \mu_{i+1}; p_{d1}(i) = 1; p_{d2}(i) = 0; \quad i = 1, \dots, K-2 \end{aligned}$$

#### Step 2. For $i=2, 3, \dots, K-1$ :

Analyse line  $L(i-1)$  and calculate  $E(i-1)$ ,  $p_s(i-1)$ ,  $p_{u1}^r(i-1)$ , and  $p_{u2}^r(i-1)$

$$\begin{aligned} \frac{1}{e_u(i)} &= \frac{1}{E(i-1)} + \frac{1}{e_i} - \frac{1}{e_d(i-1)} \\ \alpha_u(i) &= \frac{1}{\mu_i \left( \frac{\left( \frac{1}{e_u(i)} - 1 \right) E(i-1)}{p_s(i-1)} - 1 \right) \left( \frac{p_{u1}^r(i-1)}{\mu_{u1}(i-1)} + \frac{p_{u2}^r(i-1)}{\mu_{u2}(i-1)} \right) + 1} \end{aligned}$$

$$\begin{aligned} m_u^{(1)}(i) &= \frac{\alpha_u(i)p_{u1}^r(i-1)}{\mu_{u1}(i-1)} + \frac{\alpha_u(i)p_{u2}^r(i-1)}{\mu_{u2}(i-1)} + \frac{1 - \alpha_u(i)}{\mu_i} \\ m_u^{(2)}(i) &= \frac{2\alpha_u(i)p_{u1}^r(i-1)}{\mu_{u1}(i-1)^2} + \frac{2\alpha_u(i)p_{u2}^r(i-1)}{\mu_{u2}(i-1)^2} + \frac{2(1 - \alpha_u(i))}{\mu_i^2} \\ m_u^{(3)}(i) &= \frac{6\alpha_u(i)p_{u1}^r(i-1)}{\mu_{u1}(i-1)^3} + \frac{6\alpha_u(i)p_{u2}^r(i-1)}{\mu_{u2}(i-1)^3} + \frac{6(1 - \alpha_u(i))}{\mu_i^3} \end{aligned}$$

Calculate the HE parameters ( $\mu_{u1}(i)$ ,  $\mu_{u2}(i)$ ,  $p_{u1}(i)$ ,  $p_{u2}(i)$ ) of the repair time distribution of  $M_u(i)$  (using the formulas in given Appendix B)

$$\lambda_u(i) = \frac{\left( \frac{1}{e_u(i)} - 1 \right)}{\frac{p_{u1}(i)}{\mu_{u1}(i)} + \frac{p_{u2}(i)}{\mu_{u2}(i)}}$$

**Step 3.** For  $i = K-2, K-3, \dots, 1$ :

Analyse line  $L(i+1)$  and calculate  $E(i+1)$ ,  $p_b(i+1)$ ,  $p_{d1}^r(i+1)$ , and  $p_{d2}^r(i+1)$

$$\frac{1}{e_d(i)} = \frac{1}{E(i+1)} + \frac{1}{e_{i+1}} - \frac{1}{e_u(i+1)}$$

$$\alpha_d(i) = \frac{1}{\mu_{i+1} \left( \frac{\left( \frac{1}{e_d(i)} - 1 \right) E(i+1)}{p_b(i+1)} - 1 \right) \left( \frac{p_{d1}^r(i+1)}{\mu_{d1}(i+1)} + \frac{p_{d2}^r(i+1)}{\mu_{d2}(i+1)} \right) + 1}$$

$$m_d^{(1)}(i) = \frac{\alpha_d(i)p_{d1}^r(i+1)}{\mu_{d1}(i+1)} + \frac{\alpha_d(i)p_{d2}^r(i+1)}{\mu_{d2}(i+1)} + \frac{1 - \alpha_d(i)}{\mu_{i+1}}$$

$$m_d^{(2)}(i) = \frac{2\alpha_d(i)p_{d1}^r(i+1)}{\mu_{d1}(i+1)^2} + \frac{2\alpha_d(i)p_{d2}^r(i+1)}{\mu_{d2}(i+1)^2} + \frac{2(1 - \alpha_d(i))}{\mu_{i+1}^2}$$

$$m_d^{(3)}(i) = \frac{6\alpha_d(i)p_{d1}^r(i+1)}{\mu_{d1}(i+1)^3} + \frac{6\alpha_d(i)p_{d2}^r(i+1)}{\mu_{d2}(i+1)^3} + \frac{6(1 - \alpha_d(i))}{\mu_{i+1}^3}$$

Calculate the HE parameters ( $\mu_{d1}(i)$ ,  $\mu_{d2}(i)$ ,  $p_{d1}(i)$ ,  $p_{d2}(i)$ ) of the repair time distribution of  $M_d(i)$  (using the formulas in given Appendix B)

$$\lambda_d(i) = \frac{\left( \frac{1}{e_d(i)} - 1 \right)}{\frac{p_{d1}(i)}{\mu_{d1}(i)} + \frac{p_{d2}(i)}{\mu_{d2}(i)}}$$

**Step 4.** Go to Step 2 until convergence of the unknown parameters ( $\lambda_u(i)$ ,  $\mu_{u1}(i)$ ,  $\mu_{u2}(i)$ ,  $p_{u1}(i)$ ,  $p_{u2}(i)$ ,  $\lambda_d(i)$ ,  $\mu_{d1}(i)$ ,  $\mu_{d2}(i)$ ,  $p_{d1}(i)$  and  $p_{d2}(i)$ ),  $i=1, \dots, K-1$

## 5. Numerical Experiments

In this section, we present two examples that illustrate the behavior of the new decomposition method. For each example, we provide the results obtained using the original decomposition method with exponential approximations of the repair time distributions as described in [6], referred to as the E-method, the method presented in [8] with general exponential approximations of the repair time distributions, referred to as the GE-method, and the new method presented in this paper, referred to as the HE-method. For each example the convergence parameter is set to  $1.10^{-7}$ . This means that we stop the algorithm if the relative difference of each parameter ( $\lambda_u(i)$ ,  $\mu_{u1}(i)$ ,  $\mu_{u2}(i)$ ,  $p_{u1}(i)$ ,  $p_{u2}(i)$ ,  $\lambda_d(i)$ ,  $\mu_{d1}(i)$ ,  $p_{d1}(i)$  and  $p_{d2}(i)$ ,  $i = 1, \dots, K-1$ ) between two iterations of the algorithm is less than  $1.10^{-7}$ . The three different algorithms are computationally very efficient and give the results almost instantaneously on a Pentium100 machine (see table 5 for a comparison of the time required to achieve convergence for each algorithm). We compare these results with simulation results of the continuous flow model of the original production lines. We ran long enough simulations so that the outcome of these simulations can be used as a reference to compare the three decomposition methods as can be seen from the corresponding confidence intervals. For each example, we provide the production rate of the line as well as the average buffer levels. We also provide the relative error of each decomposition method with respect to the simulation results. In all examples, the common speed of the machines is  $U=1$ .

The first example (Example 1) pertains to a line consisting of 10 machines. The parameters are given in table 1. This example, although not coming directly from an industrial case, is however representative of production lines that are encountered in industry. The isolated efficiencies of the machines range from 0.870 to 0.952. The average times to repair are fairly different from one machine to the other (ratio of 1 to 10). We consider three different sets of buffer capacities, referred to as A, B, and C. The buffer capacities of example 1-B are twice those of example 1-A, and the buffer capacities of example 1-C are twice those of example 1-B. The results obtained using the E-method, the GE-method and the HE-method are given in table 2. The main performance parameter of interest is the production rate of the line, which can be interpreted as the production capacity of the system. For the three configurations, it appears that the production rates obtained using the GE-method or the HE-method are significantly more accurate than those obtained using the E-method. Indeed, the errors of the GE-method and the HE-method are of the order of 1%, whereas the error of the E-method can be close to 10% (see example 1-A). The significant errors encountered with the E-method is due to the fact that the exponential approximation of the repair time is a poor approximation of the actual repair time distributions in situations where the average repair time of the machines are very different, which is the case in example 1. For the three configurations, the average error of the GE-method is 0.73%, and the average error of the HE-method is 0.67%, whereas the average error of the E-method is 5.14%. On the other hand, the results pertaining to the buffer levels are not as significantly different. Nevertheless, it appears that the HE-method does slightly better than the GE-method, which in turns does slightly better than the E-method. Indeed, the average error of the HE-method is 5.9%, whereas that of the GE-method is 7.8% and that of the E-method is 12.4%.

The second example (Example 2) is derived from example 1 as follows. The average time to failure (respectively time to repair) of machines 2, 4, 6, 8 and 10 are



multiplied by 2 (respectively 4) with respect to the parameters of the first example. The other machines are unchanged. The isolated efficiencies of the machines now range from 0.769 to 0.952. The average times to repair are now significantly different from one machine to the other (ratio of 1 to 40). We consider the same three different sets of buffer capacities, referred to as A, B, and C. . The parameters are given in table 3. The results obtained using the E-method, the GE-method and the HE-method are given in table 4. Let us first discuss the results pertaining to the production rate. As expected, the results obtained using the E-method are fairly poor. Indeed, the error is larger than 10% for the three configurations. Now, it appears that for this example, the GE-method also leads to some significant errors, in particular when the buffer sizes are small (the error is close to 5% for configuration 2-A). On the other hand, the HE-method is still fairly robust since the largest error is less than 2%. For the three configurations, the average error of the GE-method is 2.8%, whereas the average error of the HE-method is 1.30% and the average error of the E-method is 13.43%. For the average buffer levels, the superiority of the HE-method over the other two methods becomes clearer. Indeed, the average (respectively maximum) error of the HE-method is 5.9%, (respectively 17.84%) whereas that of the GE-method is 9.9% (respectively 28.43) and that of the E-method is 18.1% (respectively 39.93).

The conclusions drawn by means of these two examples were actually confirmed by the results obtained with many other examples we tested.(see [15] for other examples) These conclusions can be summarized as follows. The E-method can lead to large errors in the estimation of the production rate in situations where the average repair times of the different machines have different orders of magnitudes. In such cases, the GE-method does provide good results, except when the buffer sizes are too small, in which case it can also lead to significant errors. On the other hand the HE-method appears to be very robust in the sense that regardless of the parameters of the production line (reliability parameters of the machines and sizes of the buffers), it always provide reasonably accurate results.

Let us briefly discuss the convergence and computational complexity of the new algorithm, referred to as the HE-DDX algorithm, and compare them with those of GE-DDX algorithm, derived for the GE-method, and the E-DDX algorithm derived for the E-method. We tested many examples with quite different parameters and on all these examples, the GE-DDX and HE-DDX algorithms always converged. The time to achieve convergence of the GE-DDX algorithm is very similar to the convergence time of the original E-DDX algorithm, whereas the convergence time of the HE-DDX algorithm can be ten times larger (see table 5). This is due to the fact that the analysis of each two-machine production line requires significantly more time in case the repair time distribution of the equivalent machines is characterized by HE-distributions. However, it should be noticed that even the HE-DDX algorithm is very fast (convergence is always reached in less than one second for production lines with a number of machines of the order of 10).

## 6. Conclusion

In this paper, we proposed an improvement of Gershwin's original decomposition method that provides accurate results in situations where the GE-method and the original E-method can lead to significant errors. This is the case when the reliability parameters (average failure time and average repair time) of the different machines have different orders of magnitude and the buffer capacities are small. Such a situation may be encountered in real production lines. The basic difference between the decomposition method presented in this paper with that of Gershwin and that presented in [8] is that the times to repair of the equivalent machines are modeled as two-stage hyper-exponential distribution instead of generalized exponential or exponential distributions. This allows us to use a three-moment approximation instead of a two-moment approximation or a one-moment approximation of the repair time distributions of these equivalent machines. Our results show that the HE-method is very robust in terms of accuracy, while still being fast enough to be used in an interactive way.

## References

- [1] R. Alvarez, Y. Dallery and R. David, "A study of the continuous flow model of production lines with unreliable machines and finite buffers", *Journal of Manufacturing Systems*, Volume 13/No. 3, pp. 221-234.
- [2] J. A. Buzacott, "Automatic transfer lines with buffer stocks", *Int. J. Prod. Res.*, Vol. 5, N°3, pp. 182-200, 1967.
- [3] J.A. Buzacott and L.E. Hanifin, "Models of automatic transfer lines with inventory banks: a review and comparison", *AIIE Transactions*, Vol. 10, N°2, pp. 197-207, 1978.
- [4] Y. Dallery, "On modeling failure and repair times in stochastic models of manufacturing systems using generalized exponential distributions", *Queuing Systems (Theory and Application)* Vol. 15, pp. 199-209, 1994.
- [5] Y. Dallery, R. David and X.L. Xie, "An efficient algorithm for analysis of transfer lines with unreliable machines and finite buffers", *IIE Transactions*, Vol. 20, pp. 280-283, 1988.
- [6] Y. Dallery, R. David and X.-L. Xie, "Approximate analysis of transfer lines with unreliable machines and finite buffers", *IEEE Transactions on Automatic Control*, Vol. 34, N°9, pp. 943-953, September 1989.
- [7] Y. Dallery and S.B. Gershwin, "Manufacturing flow line systems: a review of models and analytical results", *Queuing Systems Theory and Applications*, Vol. 12, pp. 3-94, 1992.

- [8] Y. Dallery and H. Le Bihan, "An improved decomposition method for the analysis of production lines with unreliable machines and finite buffers", *INRIA/IEEE, (ETFA'95)*, Paris, France, October 1995.
- [9] D. Dubois and J.-P. Forestier, "Productivité et en-cours moyens d'un ensemble de deux machines séparées par une zone de stockage", *RAIRO Automatique*, Vol. 16, N°2, pp. 105-132, 1982.
- [10] Y. Frein, C. Commault and Y. Dallery, "Modeling and analysis of closed-loop production lines with unreliable machines and finite buffers", *IIE Transactions* 28, 545-554, 1996
- [11] S.B. Gershwin, "An efficient decomposition method for the approximate evaluation of tandem queues with finite storage space and blocking", *Operations Research*, Vol. 35, N°2, pp. 291-305, March-April 1987.
- [12] S.B. Gershwin and I.C. Schick, "Continuous model of an unreliable two-stage material flow system with a finite interstage buffer", Tech. Rep. LIDS-R-1039, Massachusetts Institute of Technology, 1980.
- [13] S.B. Gershwin and I.C. Schick, "Modelling and analysis of three-stage transfer lines with unreliable machines and finite buffers", *Operations Research*, Vol. 31, n°2, pp. 354-380, 1983.
- [14] D.D Kouvatsos, Maximum entropy and the G/G/1/N queue, *Acta Informatica* 23, pp. 545-565, 1986.
- [15] H. Le Bihan, De nouvelles méthodes analytique pour l'évaluation de performances de lignes de production, PhD Thesis, Université Pierre et Marie Curie, in preparation.
- [16] H. Le Bihan and Y. Dallery, Analysis of the continuous flow model of a two-machine production line with exponential failure time and hyper-exponential repair time distribution, Technical report LIP6, in preparation.
- [17] B. Zimmern, "Etude de la propagation des arrêts aléatoires dans les chaînes de production", *Revue de Statistique Appliquées*, Vol. 4, pp. 85-104, 1956.

## **Appendix A : Analysis of the continuous flow model of a two-machine production line with exponential failure time and two-stage hyper-exponential repair time distributions**

In this appendix, we briefly show the analysis of the continuous flow model of a two-machine production line with exponential failure time and two-stage hyper-exponential repair time distributions. Details pertaining to the analysis and the formulas for the performance parameters can be found in [16]. Consider the continuous flow model of a two-machine production line with a finite storage buffer. Each machine can fail. Let  $i = 1, 2$  denote the number of the machine in the production line ( $i=1$  for the upstream machine and  $i=2$  for the downstream machine). The time to failure of machine  $i$  is exponentially distributed with rate  $\lambda_i$  ( $i = 1, 2$ ). The distribution of the repair time of machine  $i$  is a two-stage hyper-exponential distribution with parameters  $\mu_{i1}, \mu_{i2}, p_{i1}$  and  $p_{i2}$ .

Let  $C$  be the finite capacity of the buffer. Let  $U$  be the constant transfer rate of all the machines of the line. Let  $x$  be the quantity of material in the buffer and  $\alpha_i$  ( $i=0, 1, 2$ ) be a variable indicating whether machine  $i$  is operational ( $\alpha_i=0$ ), under repair by the stage 1 ( $\alpha_i=1$ ) of the hyper-exponential distribution of the repair times, or under repair by the stage 2 ( $\alpha_i=2$ ).

Let  $f_{\alpha_1, \alpha_2}(x)$  be the steady-state probability density of the internal states  $(\alpha_1, \alpha_2, x)$  where  $0 < x < C$ . Let  $P_{\alpha_1, \alpha_2}(0)$  be the steady-state probabilities of the boundary states where  $x = 0$ . Let  $P_{\alpha_1, \alpha_2}(C)$  be the steady-state probabilities of the boundary states where  $x = C$ .

### **Internal equations of the steady-state probability density**

We define internal states as states  $(\alpha_1, \alpha_2, x)$  where  $0 < x < C$ . All other states are boundary states. Internal equations are the balance equations that do not include any boundary states. The rest are called boundary equations.

$$p_{11}\lambda_1 f_{01}(x) + p_{21}\lambda_2 f_{10}(x) - (\mu_{11} + \mu_{21})f_{11}(x) = 0 \quad (\text{A1})$$

$$p_{12}\lambda_1 f_{01}(x) + p_{21}\lambda_2 f_{20}(x) - (\mu_{12} + \mu_{21})f_{21}(x) = 0 \quad (\text{A2})$$

$$p_{11}\lambda_1 f_{02}(x) + p_{22}\lambda_2 f_{10}(x) - (\mu_{11} + \mu_{22})f_{12}(x) = 0 \quad (\text{A3})$$

$$p_{12}\lambda_1 f_{02}(x) + p_{22}\lambda_2 f_{20}(x) - (\mu_{12} + \mu_{22})f_{22}(x) = 0 \quad (\text{A4})$$

$$-U \frac{\partial f_{10}}{\partial x}(x) = p_{11}\lambda_1 f_{00}(x) + \mu_{22}f_{12}(x) + \mu_{21}f_{11}(x) - (\mu_{11} + \lambda_2)f_{10}(x) \quad (\text{A5})$$

$$-U \frac{\partial f_{20}}{\partial x}(x) = p_{12}\lambda_1 f_{00}(x) + \mu_{22}f_{22}(x) + \mu_{21}f_{21}(x) - (\mu_{12} + \lambda_2)f_{20}(x) \quad (\text{A6})$$

$$U \frac{\partial f_{01}}{\partial x}(x) = \mu_{12} f_{21}(x) + \mu_{11} f_{11}(x) + p_{21} \lambda_2 f_{00}(x) - (\mu_{21} + \lambda_1) f_{20}(x) \quad (\text{A7})$$

$$U \frac{\partial f_{02}}{\partial x}(x) = \mu_{12} f_{22}(x) + \mu_{11} f_{12}(x) + p_{22} \lambda_2 f_{00}(x) - (\mu_{22} + \lambda_1) f_{02}(x) \quad (\text{A8})$$

$$\mu_{11} f_{10}(x) + \mu_{12} f_{20}(x) + \mu_{21} f_{01}(x) + \mu_{22} f_{02}(x) - (\lambda_2 + \lambda_1) f_{00}(x) = 0 \quad (\text{A9})$$

### **Boundary equations of the steady-state probability**

$$\mu_{21} P_{01}(C) = p_{21} \lambda_2 P_{00}(C) + f_{01}(C) \quad (\text{A10})$$

$$\mu_{22} P_{02}(C) = p_{22} \lambda_2 P_{00}(C) + f_{02}(C) \quad (\text{A11})$$

$$(\lambda_1 + \lambda_2) P_{00}(C) = \mu_{21} P_{01}(C) + \mu_{22} P_{02}(C) \quad (\text{A12})$$

$$\mu_{11} P_{10}(0) = p_{11} \lambda_1 P_{00}(0) + f_{10}(0) \quad (\text{A13})$$

$$\mu_{12} P_{20}(0) = p_{12} \lambda_1 P_{00}(0) + f_{20}(0) \quad (\text{A14})$$

$$(\lambda_1 + \lambda_2) P_{00}(0) = \mu_{11} P_{10}(0) + \mu_{12} P_{20}(0) \quad (\text{A15})$$

$$P_{01}(0) = P_{02}(0) = P_{10}(C) = P_{20}(C) = 0 \quad (\text{A16})$$

$$P_{11}(0) = P_{12}(0) = P_{21}(0) = P_{22}(0) = 0 \quad (\text{A17})$$

$$P_{11}(C) = P_{12}(C) = P_{21}(C) = P_{22}(C) = 0 \quad (\text{A18})$$

$$f_{10}(C) = p_{11} \lambda_1 P_{00}(C) \quad (\text{A19})$$

$$f_{20}(C) = p_{12} \lambda_1 P_{00}(C) \quad (\text{A20})$$

$$f_{01}(0) = p_{21} \lambda_2 P_{00}(0) \quad (\text{A21})$$

$$f_{02}(0) = p_{22} \lambda_2 P_{00}(0) \quad (\text{A22})$$

### **Analysis of internal equations**

By summing all the internal equations, we obtain the following relationship:

$$\frac{\partial f_{01}(x)}{\partial x} + \frac{\partial f_{02}(x)}{\partial x} = \frac{\partial f_{10}(x)}{\partial x} + \frac{\partial f_{20}(x)}{\partial x}$$

which implies that:

$$f_{01}(x) + f_{02}(x) = f_{10}(x) + f_{20}(x) + K$$

By using the boundary equations, we can find that  $K$  is equal to zero. As a result, the previous equation can be written as:

$$f_{01}(x) + f_{02}(x) = f_{10}(x) + f_{20}(x) \quad (\text{A23})$$

By using equations (A1), (A2), (A3), (A4), (A9) and (A23), equations (A5), (A7), and (A8) can be written as:

$$\begin{aligned} U \frac{\partial f_{10}(x)}{\partial x} &= \left( \lambda_2 + \mu_{11} + \frac{p_{11}\lambda_1}{\lambda_1 + \lambda_2} (\mu_{12} - \mu_{11}) - \frac{p_{22}\lambda_2\mu_{22}}{\mu_{11} + \mu_{22}} - \frac{p_{21}\lambda_2\mu_{21}}{\mu_{11} + \mu_{21}} \right) f_{10}(x) \\ &\quad - p_{11}\lambda_1 \left( \frac{\mu_{12} + \mu_{21}}{\lambda_1 + \lambda_2} + \frac{\mu_{21}}{\mu_{11} + \mu_{21}} \right) f_{01}(x) \\ &\quad - p_{11}\lambda_1 \left( \frac{\mu_{12} + \mu_{22}}{\lambda_1 + \lambda_2} + \frac{\mu_{22}}{\mu_{11} + \mu_{22}} \right) f_{02}(x) \\ U \frac{\partial f_{01}(x)}{\partial x} &= p_{21}\lambda_2 \left( \frac{\mu_{11} + \mu_{12}}{\lambda_1 + \lambda_2} + \frac{\mu_{11}}{\mu_{11} + \mu_{21}} - \frac{\mu_{12}}{\mu_{12} + \mu_{21}} \right) f_{10}(x) \\ &\quad + \left( -\lambda_1 - \mu_{21} + \frac{p_{12}\lambda_1\mu_{12}}{\mu_{12} + \mu_{21}} + \frac{p_{11}\lambda_1\mu_{11}}{\mu_{11} + \mu_{21}} + \frac{p_{21}\lambda_2(\mu_{12} + \mu_{21})}{\lambda_1 + \lambda_2} + \frac{p_{21}\lambda_2\mu_{12}}{\mu_{12} + \mu_{21}} \right) f_{01}(x) \\ &\quad + p_{21}\lambda_2 \left( \frac{\mu_{12} + \mu_{22}}{\lambda_1 + \lambda_2} + \frac{\mu_{12}}{\mu_{12} + \mu_{21}} \right) f_{02}(x) \\ U \frac{\partial f_{02}(x)}{\partial x} &= p_{22}\lambda_2 \left( \frac{\mu_{11} + \mu_{12}}{\lambda_1 + \lambda_2} + \frac{\mu_{11}}{\mu_{11} + \mu_{22}} - \frac{\mu_{12}}{\mu_{12} + \mu_{22}} \right) f_{10}(x) \\ &\quad + p_{22}\lambda_2 \left( \frac{\mu_{12} + \mu_{21}}{\lambda_1 + \lambda_2} + \frac{\mu_{12}}{\mu_{12} + \mu_{22}} \right) f_{01}(x) \\ &\quad + \left( -\lambda_1 - \mu_{22} + \frac{p_{12}\lambda_1\mu_{12}}{\mu_{12} + \mu_{22}} + \frac{p_{11}\lambda_1\mu_{11}}{\mu_{11} + \mu_{22}} + \frac{p_{22}\lambda_2(\mu_{12} + \mu_{22})}{\lambda_1 + \lambda_2} + \frac{p_{22}\lambda_2\mu_{12}}{\mu_{12} + \mu_{22}} \right) f_{02}(x) \end{aligned}$$

The solutions of the previous system is given by the following equations:

$$\begin{aligned} f_{10}(x) &= C_1 x_1 e^{R_1 x} + C_2 x_2 e^{R_2 x} + C_3 x_3 e^{R_3 x} \\ f_{01}(x) &= C_1 y_1 e^{R_1 x} + C_2 y_2 e^{R_2 x} + C_3 y_3 e^{R_3 x} \\ f_{02}(x) &= C_1 z_1 e^{R_1 x} + C_2 z_2 e^{R_2 x} + C_3 z_3 e^{R_3 x} \end{aligned}$$

By using the boundary and internal equations and the following normalization equation,

$$\sum_{\alpha_1=0}^2 \sum_{\alpha_2=0}^2 \left( \int_0^C f_{\alpha_1\alpha_2}(x) dx + P_{\alpha_1\alpha_2}(C) + P_{\alpha_1\alpha_2}(0) \right) = 1, \text{ we can derive the values of the}$$

following parameters:  $x_i, y_i, z_i, R_i, C_i$  ( $i=1,2,3$ ). From these parameters we can derive the steady-state probability densities of the internal states as well as the steady-state probabilities of the boundary states.

Let  $E$  be the efficiency of the original line.  $E$  is given by the following relationship:

$$E = \sum_{\alpha_1=0}^2 \left( \int_0^C f_{\alpha_1 0}(x) dx + P_{\alpha_1 0}(C) + P_{\alpha_1 0}(0) \right)$$

The average buffer level  $Q$  is given by:

$$Q = \sum_{\alpha_1=0}^2 \sum_{\alpha_2=0}^2 \left( \int_0^C x f_{\alpha_1\alpha_2}(x) dx + C P_{\alpha_1\alpha_2}(C) \right)$$

The probability of blocking and starvation can easily be obtained using :

$$p_s = 1 - \frac{E}{e_2} \text{ and } p_b = 1 - \frac{E}{e_1}$$

Let  $p_{11}^r$  be the probability that the residual repair times of the first machine are exponentially distributed with rate  $\mu_{11}$  and  $p_{12}^r$  be the probability that the residual repair times of the first machine are exponentially distributed with rate  $\mu_{12}$ . These two probabilities are given by :

$$p_{11}^r = \frac{p_{10}(0)\mu_{11}}{p_{10}(0)\mu_{11} + p_{20}(0)\mu_{12}}$$

$$p_{12}^r = \frac{p_{20}(0)\mu_{12}}{p_{10}(0)\mu_{11} + p_{20}(0)\mu_{12}}$$

Similarly  $p_{21}^r$ , the probability that the residual repair times of the second machine are exponentially distributed with rate  $\mu_{21}$  and  $p_{22}^r$ , the probability that the residual repair times of the second machine are exponentially distributed with rate  $\mu_{22}$  are given by the two following relationships:

$$p_{21}^r = \frac{p_{01}(0)\mu_{21}}{p_{01}(0)\mu_{21} + p_{02}(0)\mu_{22}}$$

$$p_{22}^r = \frac{p_{02}(0)\mu_{22}}{p_{01}(0)\mu_{21} + p_{02}(0)\mu_{22}}$$

## Appendix B: Three-moment approximation of an arbitrary hyper-exponential distribution by a two-stage hyper-exponential distribution.

We search the parameters of a two-stage hyper-exponential distribution such that the three first moments of this distribution are equal to those of a given hyper-exponential distribution with an arbitrary number of stages.

Let  $m^{(1)}$ ,  $m^{(2)}$  and  $m^{(3)}$  be the first, the second and the third first moment respectively of this distribution. Let  $p_1$ ,  $p_2$ ,  $\mu_1$  and  $\mu_2$  be the four parameters of the two-stage hyper-exponential distribution where  $p_1$  (respectively  $p_2$ ) is the probability that the distribution of the repair times is exponential with rate  $\mu_1$  (respectively  $\mu_2$ ). The relationships between the four parameters of the two-stage hyper-exponential distribution and the three first moments of the arbitrary hyper-exponential distribution are given by the following equations:

$$\frac{p_1}{\mu_1} + \frac{p_2}{\mu_2} = m^{(1)}$$

$$\frac{2p_1}{\mu_1^2} + \frac{2p_2}{\mu_2^2} = m^{(2)}$$

$$\frac{6p_1}{\mu_1^3} + \frac{6p_2}{\mu_2^3} = m^{(3)}$$

where  $p_1 + p_2 = 1$

Let  $D$  and  $\Delta_D$  be defined as following:

$$D = \frac{\frac{m^{(3)}}{6} - m^{(1)3}}{m^{(1)3} \left( \frac{m^{(2)}}{2m^{(1)2}} - 1 \right)} - 3$$

$$\Delta_D = 1 - \frac{1}{\frac{D^2}{4 \left( \frac{m^{(2)}}{2m^{(1)2}} - 1 \right)} + 1}$$

Considerable manipulation is required to show that the parameters  $p_1$ ,  $p_2$ ,  $\mu_1$  and  $\mu_2$  are given by the following relationships (details can be found in [13]):



$$p_1 = \frac{1 + \sqrt{\Delta_D}}{2}$$

$$p_2 = \frac{1 - \sqrt{\Delta_D}}{2}$$

if  $D \geq 0$

$$\frac{1}{\mu_1} = m^{(1)} \left( 1 - \sqrt{\frac{p_2}{p_1} \left( \frac{m^{(2)}}{2m^{(1)2}} - 1 \right)} \right)$$

$$\frac{1}{\mu_2} = m^{(1)} \left( 1 + \sqrt{\frac{p_1}{p_2} \left( \frac{m^{(2)}}{2m^{(1)2}} - 1 \right)} \right)$$

if  $D < 0$

$$\frac{1}{\mu_1} = m^{(1)} \left( 1 + \sqrt{\frac{p_2}{p_1} \left( \frac{m^{(2)}}{2m^{(1)2}} - 1 \right)} \right)$$

$$\frac{1}{\mu_2} = m^{(1)} \left( 1 - \sqrt{\frac{p_1}{p_2} \left( \frac{m^{(2)}}{2m^{(1)2}} - 1 \right)} \right)$$

It can be shown that there always exists a two-stage hyper-exponential distribution such that its first three moments match those of a given arbitrary hyper-exponential distribution. Indeed, the parameters of the two-stage hyper-exponential distribution must satisfy the two following relationships :

$$p_1 \in [0,1] \text{ and } p_2 \in [0,1] \Rightarrow \left( \frac{m^{(2)}}{2m^{(1)2}} - 2 \right) > 0 \Rightarrow Cv^2 > 1$$

$$\frac{1}{\mu_1} \geq 0 \text{ and } \frac{1}{\mu_2} \geq 0 \Rightarrow \frac{m^{(2)2}}{4m^{(1)}} \leq \frac{m^{(3)}}{6}$$

The first relationship is always true in the case of hyper-exponential distributions. To verify the second relationship we define the third first moment of a n-stage hyper-exponential distribution as:

$$m^{(1)} = \sum_{i=1}^n \frac{p_i}{\mu_i} \tag{B1}$$

$$\frac{m^{(2)}}{2} = \sum_1^n \frac{p_i}{\mu_i^2} \quad (\text{B2})$$

$$\frac{m^{(3)}}{6} = \sum_1^n \frac{p_i}{\mu_i^3} \quad (\text{B3})$$

Using (B1) and (B3) we can written:

$$\frac{m^{(1)}m^{(3)}}{6} = \sum_{i=1}^n \sum_{j>i}^n p_i p_j \left( \frac{1}{\mu_i^3 \mu_j} + \frac{1}{\mu_i \mu_j^3} \right) + \sum_{i=1}^n \frac{p_i^2}{\mu_i^4} \quad (\text{B4})$$

Similarly using (B2) we can written:

$$\frac{m^{(2)^2}}{4} = \sum_{i=1}^n \sum_{j>i}^n p_i p_j \left( \frac{2}{\mu_i^2 \mu_j^2} \right) + \sum_{i=1}^n \frac{p_i^2}{\mu_i^4} \quad (\text{B5})$$

By using equations (B4) and (B5), (B6) is given by:

$$\frac{m^{(1)}m^{(3)}}{6} - \frac{m^{(2)^2}}{4} = \sum_{i=1}^n \sum_{j>i}^n p_i p_j \left( \frac{1}{\mu_i^3 \mu_j} + \frac{1}{\mu_i \mu_j^3} \right) - \sum_{i=1}^n \sum_{j>i}^n p_i p_j \left( \frac{2}{\mu_i^2 \mu_j^2} \right) \quad (\text{B6})$$

Equation given by (B6) can be equivalently transformed into the following relationship:

$$\frac{m^{(1)}m^{(3)}}{6} - \frac{m^{(2)^2}}{4} = \sum_{i=1}^n \sum_{j>i}^n \frac{p_i p_j}{\mu_i \mu_j} \left( \frac{1}{\mu_i^2} - \frac{1}{\mu_j^2} \right)^2 \geq 0$$

which implies:  $\frac{m^{(2)^2}}{4m^{(1)}} < \frac{m^{(3)}}{6}$

		1	2	3	4	5	6	7	8	9	10
	$1/\lambda_i$	50	400	150	200	400	100	500	600	100	800
	$1/\mu_i$	5	60	10	15	40	5	40	60	5	60
	$e_i$	0.909	0.870	0.938	0.930	0.909	0.95	0.926	0.909	0.952	0.930
1-A	$C_i$	25	30	10	15	15	25	35	25	30	
1-B	$C_i$	50	60	20	30	30	50	70	50	60	
1-C	$C_i$	100	120	40	30	60	100	140	100	120	

Table 1: Data for Example 1

		X	Q <sub>1</sub>	Q <sub>2</sub>	Q <sub>3</sub>	Q <sub>4</sub>	Q <sub>5</sub>	Q <sub>6</sub>	Q <sub>7</sub>	Q <sub>8</sub>	Q <sub>9</sub>
1-A	simulation	0.7257	17.2846	20.4284	5.6098	6.6129	6.2670	8.2159	10.3845	6.6884	4.6173
	+/-	0.0008	0.027	0.0381	0.0124	0.0209	0.0217	0.0494	0.0629	0.027	0.0294
	E-method	0.7880	16.5771	18.3125	5.2796	6.5738	6.5539	8.0139	9.3169	7.2413	3.8152
	<b>error(%)</b>	<b>+8.58</b>	<b>-4.09</b>	<b>-10.36</b>	<b>-5.89</b>	<b>-0.59</b>	<b>+4.58</b>	<b>-2.46</b>	<b>-10.28</b>	<b>+8.27</b>	<b>-17.37</b>
	GE-method	0.7230	17.0377	21.1790	6.1467	6.9562	5.4191	7.6964	9.4754	5.6560	4.0028
	<b>error(%)</b>	<b>-0.37</b>	<b>-1.43</b>	<b>+3.67</b>	<b>+9.57</b>	<b>+5.19</b>	<b>-13.53</b>	<b>-6.32</b>	<b>-8.75</b>	<b>-15.44</b>	<b>-13.31</b>
	HE-method	0.7308	17,0754	20,7937	5,5658	6,4954	6,1183	7,4102	9,0655	6,4318	4,0185
<b>error(%)</b>	<b>+0,70</b>	<b>-1,21</b>	<b>+1,79</b>	<b>-0,78</b>	<b>-1,78</b>	<b>-2,37</b>	<b>-9,81</b>	<b>-12,70</b>	<b>-3,84</b>	<b>-12,97</b>	
1-B	simulation	0.7919	34.2268	36.9555	10.9399	13.0374	11.2069	17.5750	22.3478	12.5643	11.6938
	+/-	0.0001	0.0077	0.0013	0.0034	0.0061	0.0060	0.0113	0.0171	0.0093	0.0109
	E-method	0.8227	31.2972	31.2859	9.6343	11.8810	11.2543	13.8858	18.8962	12.7172	9.8993
	<b>error(%)</b>	<b>+3.89</b>	<b>-8.56</b>	<b>-15.34</b>	<b>-11.93</b>	<b>-8.87</b>	<b>+0.42</b>	<b>-20.99</b>	<b>-15.44</b>	<b>+1.22</b>	<b>-15.35</b>
	GE-method	0.7854	33.1647	38.3790	11.5549	12.7199	10.0923	15.2029	19.7857	12.3587	10.4235
	<b>error(%)</b>	<b>-0.82</b>	<b>-3.10</b>	<b>+3.85</b>	<b>+5.62</b>	<b>-2.44</b>	<b>-9.95</b>	<b>-13.50</b>	<b>-11.46</b>	<b>-1.64</b>	<b>-10.86</b>
	HE-method	0,792	33,2458	37,6359	10,605	12,0645	10,9034	15,8459	20,259	12,3961	10,6108
<b>error(%)</b>	<b>+0,01</b>	<b>-2,87</b>	<b>+1,84</b>	<b>-3,06</b>	<b>-7,46</b>	<b>-2,71</b>	<b>-9,84</b>	<b>-9,35</b>	<b>-1,34</b>	<b>-9,26</b>	
1-C	simulation	0.8268	66.8602	60.8391	21.1887	26.2214	18.4280	36.2305	47.4257	21.6445	28.0408
	+/-	0.0001	0.0421	0.0948	0.0212	0.0435	0.0427	0.0842	0.1383	0.0546	0.0854
	E-method	0.8512	58.2908	43.1900	17.1383	20.9367	15.5488	28.2921	39.9943	17.3256	22.8954
	<b>error(%)</b>	<b>+2.95</b>	<b>-12.82</b>	<b>-29.01</b>	<b>-19.12</b>	<b>-20.15</b>	<b>-15.62</b>	<b>-21.91</b>	<b>-15.67</b>	<b>-19.95</b>	<b>-18.35</b>
	GE-method	0.8350	62.9057	61.0857	20.7649	22.8121	17.1868	30.1355	41.6920	22.7045	25.4899
	<b>error(%)</b>	<b>+0.99</b>	<b>-5.91</b>	<b>+0.41</b>	<b>-2.00</b>	<b>-13.00</b>	<b>-6.74</b>	<b>-16.82</b>	<b>-12.09</b>	<b>+4.90</b>	<b>-9.10</b>
	HE-method	0.8374	62,5861	59,1195	19,8889	23,0857	17,1141	31,9574	43,9566	21,1452	25,7703
<b>error(%)</b>	<b>+1,28</b>	<b>-6,39</b>	<b>-2,83</b>	<b>-6,13</b>	<b>-11,96</b>	<b>-7,13</b>	<b>-11,79</b>	<b>-7,31</b>	<b>-2,31</b>	<b>-8,10</b>	

Table 2: Comparison of the results obtained using the three decomposition methods (example 1)

		1	2	3	4	5	6	7	8	9	10
	$1/\lambda_i$	50	800	150	400	400	200	500	1200	100	1600
	$1/\mu_i$	5	240	10	60	40	20	40	240	5	240
	$e_i$	0.909	0.769	0.938	0.87	0.909	0.909	0.926	0.833	0.952	0.87
2-A	$C_i$	25	30	10	15	15	25	35	25	30	
2-B	$C_i$	50	60	20	30	30	50	70	50	60	
2-C	$C_i$	100	120	40	30	60	100	140	100	120	

Table 3: Data for Example 2

		X	Q <sub>1</sub>	Q <sub>2</sub>	Q <sub>3</sub>	Q <sub>4</sub>	Q <sub>5</sub>	Q <sub>6</sub>	Q <sub>7</sub>	Q <sub>8</sub>	Q <sub>9</sub>
2-A	simulation	0.5476	19.7957	21.9794	5.9581	7.7096	6.9254	8.1589	9.8485	5.7446	4.0244
	+/-	0.0007	0.0122	0.0375	0.0114	0.0180	0.0207	0.0370	0.0549	0.0257	0.0307
	E-method	0.6285	19.4582	19.4528	5.1377	6.3805	5.8770	7.4793	11.7612	8.0386	3.6234
	<b>error(%)</b>	<b>+14.77</b>	<b>-1.70</b>	<b>-11.50</b>	<b>-13.77</b>	<b>-17.24</b>	<b>-15.14</b>	<b>-8.33</b>	<b>+19.42</b>	<b>+39.93</b>	<b>-9.96</b>
	GE-method	0.5224	18.4646	22.1775	6.9203	7.8791	6.3234	8.1173	9.8347	4.1113	3.6774
	<b>error(%)</b>	<b>-4.60</b>	<b>-6.72</b>	<b>+0.90</b>	<b>+16.15</b>	<b>+2.20</b>	<b>-8.69</b>	<b>-0.51</b>	<b>-0.14</b>	<b>-28.43</b>	<b>-8.62</b>
2-B	simulation	0.5539	20.0935	22.6185	6.0175	7.5509	6.6764	7.7633	8.8142	5.2903	3.3242
	+/-	<b>+1.15</b>	<b>+1.50</b>	<b>+2.91</b>	<b>+1.00</b>	<b>-2.06</b>	<b>-3.60</b>	<b>-4.85</b>	<b>-10.50</b>	<b>-7.91</b>	<b>-17.40</b>
	E-method	0.5970	40.3525	41.3476	11.5761	14.6174	13.3527	16.8955	22.6336	11.7380	10.3920
	+/-	0.0002	0.0103	0.0228	0.0083	0.0148	0.0143	0.0229	0.0385	0.0223	0.0287
	E-method	0.6827	39.5146	36.4460	8.8814	10.7031	10.5062	13.4509	22.9703	16.0016	8.8076
	<b>error(%)</b>	<b>+14.36</b>	<b>-2.08</b>	<b>-11.85</b>	<b>-23.28</b>	<b>-26.78</b>	<b>-21.32</b>	<b>-20.39</b>	<b>+1.49</b>	<b>+36.32</b>	<b>-15.25</b>
2-C	simulation	0.5779	38.4531	43.0505	13.7808	15.2080	12.1912	15.7651	20.6955	9.1171	8.8126
	+/-	<b>-3.20</b>	<b>-4.71</b>	<b>+4.12</b>	<b>+19.05</b>	<b>+4.04</b>	<b>-8.70</b>	<b>-6.69</b>	<b>-8.56</b>	<b>-22.33</b>	<b>-15.20</b>
	E-method	0.6077	40.8673	42.9696	11.5858	14.3059	13.0935	16.0473	19.8744	10.5427	8.5385
	+/-	<b>+1.79</b>	<b>+1.28</b>	<b>+3.92</b>	<b>+0.08</b>	<b>-2.13</b>	<b>-1.94</b>	<b>-5.02</b>	<b>-12.19</b>	<b>-10.18</b>	<b>-17.84</b>
	E-method	0.6563	80.3691	72.4321	22.5689	26.3027	24.6641	34.6635	53.6346	24.6085	27.5443
	+/-	0.0008	0.0935	0.2440	0.0670	0.1123	0.1274	0.2439	0.3590	0.1368	0.1740
2-C	E-method	0.7296	78.5173	60.2291	14.8528	16.3419	17.6390	25.3253	45.1407	26.9122	22.0427
	<b>error(%)</b>	<b>+11.17</b>	<b>-2.30</b>	<b>-16.85</b>	<b>-34.19</b>	<b>-37.87</b>	<b>-28.48</b>	<b>-26.94</b>	<b>-15.84</b>	<b>+9.36</b>	<b>-19.97</b>
	GE-method	0.6523	77.3405	78.4056	26.6536	27.9996	22.9221	30.2500	45.1272	21.1203	23.0181
	<b>error(%)</b>	<b>-0.61</b>	<b>-3.77</b>	<b>+8.25</b>	<b>+18.10</b>	<b>+6.45</b>	<b>-7.06</b>	<b>-12.73</b>	<b>-15.86</b>	<b>-14.17</b>	<b>-16.43</b>
	HE-method	0.6700	80.3439	74.8058	22.0147	25.3538	24.1737	32.3210	47.0364	22.2008	23.8824
	<b>error(%)</b>	<b>+0.98</b>	<b>-0.03</b>	<b>+3.28</b>	<b>-2.46</b>	<b>-3.61</b>	<b>-1.99</b>	<b>-6.76</b>	<b>-12.30</b>	<b>-9.78</b>	<b>-13.29</b>

Table 4: Comparison of the results obtained using the three decomposition methods (example 2)

	E-DDX Algorithm ( $1.10^{-4}$ second)	GE-DDX Algorithm ( $1.10^{-4}$ second)	HE-DDX Algorithm ( $1.10^{-4}$ second)
1-A	28.02	23.08	145.60
1-B	31.87	30.77	166.48
1-C	31.87	35.16	188.46
2-A	30.05	27.02	151.78
2-B	32.85	31.05	171.40
2-C	33.01	36.28	191.50

*Table 5: Time required to achieve convergence of each algorithm with the convergence parameter equal to  $1.10^{-7}$*