



HAL
open science

Software consolidation as an efficient energy and cost saving solution

Alain Tchana, Noel de Palma, Ibrahim Safieddine, Daniel Hagimont

► **To cite this version:**

Alain Tchana, Noel de Palma, Ibrahim Safieddine, Daniel Hagimont. Software consolidation as an efficient energy and cost saving solution. *Future Generation Computer Systems*, 2016, 58, pp.1-12. 10.1016/j.future.2015.11.027 . hal-02538369

HAL Id: hal-02538369

<https://hal.science/hal-02538369>

Submitted on 9 Apr 2020

HAL is a multi-disciplinary open access archive for the deposit and dissemination of scientific research documents, whether they are published or not. The documents may come from teaching and research institutions in France or abroad, or from public or private research centers.

L'archive ouverte pluridisciplinaire **HAL**, est destinée au dépôt et à la diffusion de documents scientifiques de niveau recherche, publiés ou non, émanant des établissements d'enseignement et de recherche français ou étrangers, des laboratoires publics ou privés.



Distributed under a Creative Commons Attribution 4.0 International License



Open Archive Toulouse Archive Ouverte



OATAO is an open access repository that collects the work of Toulouse researchers and makes it freely available over the web where possible

This is an author's version published in: <http://oatao.univ-toulouse.fr/22295>

Official URL:

<https://doi.org/10.1016/j.future.2015.11.027>

To cite this version:

Tchana, Alain-Bouzaïde  and De Palma, Noel and Safieddine, Ibrahim and Hagimont, Daniel  *Software consolidation as an efficient energy and cost saving solution*. (2016) *Future Generation Computer Systems*, 58. 1-12. ISSN 0167-739X.

Any correspondence concerning this service should be sent to the repository administrator: tech-oatao@listes-diff.inp-toulouse.fr

Software consolidation as an efficient energy and cost saving solution

Alain Tchana^{a,*}, Noel De Palma^b, Ibrahim Safieddine^b, Daniel Hagimont^a

^a University of Toulouse, Toulouse, France

^b University of Grenoble Alpes, Grenoble, France

Keywords:
Virtualization
Migration
Consolidation
Cloud

A B S T R A C T

Virtual machines (VM) are used in cloud computing environments to isolate different software. They also support live migration, and thus dynamic VM consolidation. This possibility can be used to reduce power consumption in the cloud. However, consolidation in cloud environments is limited due to reliance on VMs, mainly due to their memory overhead. For instance, over a 4-month period in a real cloud located in Grenoble (France), we observed that 805 VMs used less than 12% of the CPU (of the active physical machines). This paper presents a solution introducing dynamic software consolidation. Software consolidation makes it possible to dynamically collocate several software applications on the same VM to reduce the number of VMs used. This approach can be combined with VM consolidation which collocates multiple VMs on a reduced number of physical machines. Software consolidation can be used in a private cloud to reduce power consumption, or by a client of a public cloud to reduce the number of VMs used, thus reducing costs. The solution was tested with a cloud hosting JMS messaging and Internet servers. The evaluations were performed using both the SPECjms2007 benchmark and an enterprise LAMP benchmark on both a VMware private cloud and Amazon EC2 public cloud. The results show that our approach can reduce the energy consumed in our private cloud by about 40% and the charge for VMs on Amazon EC2 by about 40.5%.

1. Introduction

Context and scope

In recent years, cloud computing has emerged as one of the best solutions to host applications for companies or individual users. For these cloud customers (hereafter called clients), its pay-per-use model reduces the cost compared to using internal IT resources. For cloud providers (hereafter called providers) one of the main challenges is limiting energy consumption in their data centers.

In 2010, for example, data centers consumed approximately 1.1%–1.5% of the world's energy [1]. Energy consumption can be minimized by limiting the number of active physical machines (PM) through sharing the same PM between several software applications and providing dynamic software consolidation (filling unused resources by grouping software). This helps to balance the variable workload (Fig. 1 top presents an example of workload variation at Facebook) due to the departure of some software.

In this paper, we considered an SaaS-based cloud model, such as RightScale [4]. This type of cloud provides a fully customizable environment, allowing clients, e.g. companies, to focus on applications. The SaaS provider offers a software catalog. Clients can select an application and request its start in a virtualized data center. The data center may belong either to the SaaS provider (private cloud), or be part of a public cloud; alternatively it can be a mixture of the

* Corresponding author.

E-mail addresses: alain.tchana@enseeiht.fr (A. Tchana), noel.depalma@imag.fr (N. De Palma), ibrahim.safieddine@imag.fr (I. Safieddine), daniel.hagimont@enseeiht.fr (D. Hagimont).

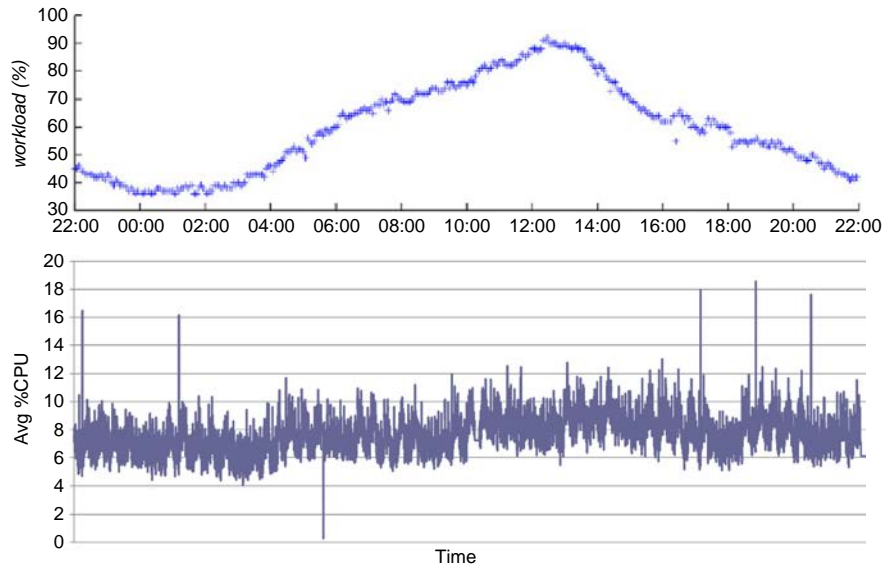

Fig. 1. Top: Typical server workload in Facebook data centers [2,3]. Bottom: Average CPU usage by VMs in Eolas¹ data center over 4 months.

two (hybrid cloud). The SaaS provider is responsible for managing the clients' software (scalability, highly-available, failover, etc.) while efficiently managing resources to reduce data center costs: power consumption when relying on its own private cloud, or resource charged for when using a public cloud.

Problem and approach

Advances in virtualization make transparent dynamic consolidation possible in the cloud. Based on this technology, the cloud runs each software application on a separate virtual machine (VM). Many studies [5–8] have described algorithms providing software consolidation through the consolidation of VMs. However, this approach is not sufficient since an infinite number of VMs cannot be packed into a single PM, even when the VMs are underused and the PM has sufficient computation power. Indeed, as argued by [9], VM packing is limited by memory. In this paper, we therefore propose a solution consolidating software onto VMs. This solution is complementary to VM consolidation. Rather than dedicating one VM to each software, we propose that the same VM be shared between several software applications. This will fill the gaps remaining inside the VM, as mentioned earlier. Fig. 2 illustrates the benefits of this solution for VMs which are already at the minimum size allowed by the cloud. Using our strategy frees 2 PMs, while VMs consolidation alone only frees 1 PM. This strategy also reduces the total number of VMs (from 4 to 2 in the illustration). This is very important in a commercial cloud to reduce the charge for VMs. Fig. 1 bottom shows the average CPU usage by 805 VMs running on 66 PMs in a real virtualized cloud located in Grenoble (France) over 4 months. Each peak on the curve represents a significant variation in workload. For each VM, less than 12% of the CPU is used, but by applying our approach a single VM can host the workload of 8 VMs. This reduces the number of VMs running from 805 to about 101, and the number of active PMs from 66 to 9.

Contributions

Software consolidation raises two main challenges that need to be addressed:

- Software isolation. Isolation ensures that if a software application fails it does not compromise the execution of another software application, it also stops software from “stealing” the resources allocated to another application.
- Software migration. Migration involves moving software from its current node to another node without interrupting the service offered by the software, and while avoiding Service Level Agreement (SLA) violations on the migrated software.

In this paper we focus only on the live migration and consolidation mechanisms. For software isolation, we rely on Docker [10]. Docker can package an application in a virtual container, that runs processes in isolation. We present a solution to consolidate software on VMs (Section 2) based on a Constraints Programming (CP) solver. The gain of our approach is modeled in terms of power and cost savings, while limiting the consolidation-related risk to performance. The genericity of the solution allows the integration of a range of live software migration mechanisms since this operation is specific to software. We present a sample migration for JMS messaging servers and LAMP servers (Section 3) which are commonly and widely deployed in the cloud. We evaluated our approach using the SPECjms2007 benchmark [11] and an enterprise Internet application benchmark (Section 4) in the context of an SaaS offering messaging and Internet software on a private VMware cloud in our laboratory and on the Amazon EC2 cloud. These evaluations showed that: (1) our approach results in reduced power consumption and costs; and (2) the efficient live migration algorithms implemented for JMS messaging and Internet web servers are viable. For the specific workload assessed, our solution reduces the electricity consumption in our private cloud by about 40% when software consolidation is combined with VM consolidation. Running the same workload on Amazon EC2 leads to a reduction in VMs charged of about 40.5%. The paper ends by presenting related work in Section 5; a discussion about the usability of the solution is provided in Section 6; and a conclusion is provided in Section 7.

2. Software consolidation

Like VMs, software consolidation is an NP-hard [12] problem. This section presents a solution that allows software consolidation in the context of an SaaS platform.

¹ <http://www.businessdecision-eolas.com/>.

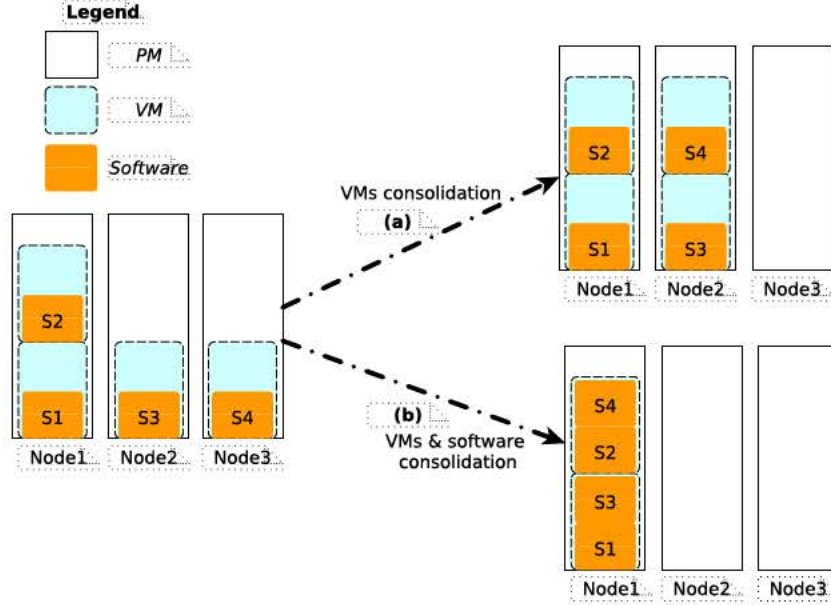

Fig. 2. Software consolidation can be combined with VM consolidation.

```

Begin
1. for each software  $s_i$  of the SaaS/PaaS do
2.   for each resource type  $r$  ( $u$ ,  $m$ , or  $o$ ) do
3.     if  $s_i^{r_{cur}}$  is insufficient and  $s_i^{r_{cur}} < s_i^{r_{max}}$  then
4.       Increase the quota of  $s_i$ 
5.     else
6.       if  $s_i^{r_{cur}}$  is excessive and  $s_i^{r_{cur}} \neq s_i^{r_{min}}$  then
7.         if The last quota decrease time is enough to avoid yo - yo effect then
8.           Decrease the quota of  $s_i$ 
9.         end if
10.       end if
11.     end if
12.   end for
13.   if The actual VM of  $s_i$  does not have enough resources for — the new quota then
14.     DestinationVM ← The Best-Fit VM which can host  $s_i$  with its new quota
15.     if DestinationVM == NULL then
16.       DestinationVM ← Allocate a new VM
17.     else
18.       Disable any timer on DestinationVM
19.     end if
20.     Compute the docker container for  $s_i$  on DestinationVM
21.     Migrate  $s_i$  to DestinationVM
22.   else
23.     Update the docker container for  $s_i$  on its current VM
24.   end if
25. end for
End

```

Algorithm 1: Software relocation

2.1. Solution overview

We focus this overview on software consolidation and migration. VM placement at start time is part of the consolidation problem. Fig. 3 presents the key components of the model system studied. *QuotaComputer* determines the amount of resources required by each software application, it uses Docker containers [10] for isolation. Each container has a different IP address, thus two applications using the same port can run in the same VM. *MonitoringEngine* is responsible for gathering statistics for both VM and software from all *MonitoringAgents*. The *ConsolidationManager* implements an online, reactive software consolidation algorithm which acts as an infinite loop. It periodically:

1. gets VMs and software status (quota consumption, which is an average of the most recent values) from the *MonitoringEngine*.

2. checks if there are software applications which need more resources and provides for them (relocation algorithm described in Algorithm 1).
3. computes software assignment on VMs to minimize the number of VMs required to support all the software running. It also computes the reconfiguration plan (a set of software migrations) that must be performed for the ideal assignment to be achieved.
4. computes software assignment on VMs to minimize the number of VMs required to support all the software running. It also computes the reconfiguration plan (a set of software migrations) that must be performed for the ideal assignment to be achieved.
5. and finally, runs (through the *LocalManager*) the reconfiguration plan.

At the end of each loop, VMs not running any software are terminated, either immediately in the case of a private cloud, or when its uptime is close to a multiple of Θ (the payment time unit) in a public cloud. In the latter case, a timer is started for each VM to be terminated so that it stops it before a new payment time unit starts. The timer is disabled when the VM is eligible to host a running application (which can be newly-installed or relocated).

Before presenting our solution in detail, there follows a list of the notations used:

- $S = \{S_1, S_2, \dots, S_m\}$ is the set of software types offered by the cloud.
- $\bar{S}_i = \{S_k, \dots\}$ is the set of software, instances of which are co-locate-able with an instance of S_i . This can be used to protect sensitive software from other potentially dangerous applications.
- For each VM vm_i , we consider three types of resources: cpu (vm_i^u), memory (vm_i^m) and IO bandwidth (vm_i^o).
- vm_i^y is the cost of running the VM for a payment time unit Θ . This is considered when the SaaS is placed on a public cloud.
- vm_i^{st} is the start time of vm_i .
- An instantiated VM is assigned an identifier (an integer). s_i^{vm} is the identifier of the VM running software s_i .
- $len(vm_i)$ is the number of software applications on vm_i .
- Like VMware does for VMs, we consider two levels of resource reservation for a software: the minimum quota and the maximum quota. $s_i^{u_{min}}$ and $s_i^{u_{max}}$ are, respectively, the minimum

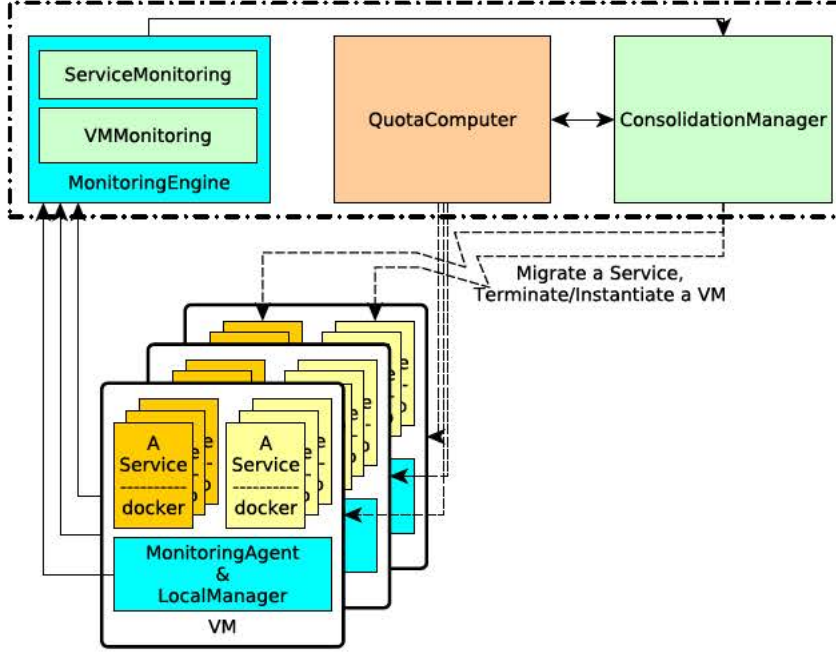

Fig. 3. Architecture of our software consolidation system.

and the maximum cpu (or memory or IO) quota. The software starts with s_i^{*min} and increases stepwise until it reaches s_i^{*max} . s_i^{*cur} denotes the current quota. Note that * is u, m or o.

- s_i^T is the acceptable service degradation threshold defined at start time for software s_i . It corresponds to its SLA.

The relocation algorithm, Algorithm 1, checks if the current resources available for each software application are insufficient, excessive or sufficient. If it is insufficient, the software acquires more resources within its maximum quota. This operation can cause the software to be relocated to another VM (an existing one or a new one). On the other hand, if the software is wasting resources, its quota is reduced; the algorithm includes a clause to avoid the frequent transitions (yo-yo effect). The choice of the destination VM (on which software is to be relocated) does not need to be optimal. Indeed, the consolidation engine will correct the placement. This will be discussed in the next section, where the formalization of the software placement problem as a Constraint Satisfaction Problem (CSP) is presented along with how we used and optimized the Choco CSP solver [13] to resolve software placement problems.

2.2. Software placement as a CSP

Definition. A CSP [14], C , is a set of constraints, L , acting on a set of variables, $\Delta = \{A_1, A_2, \dots, A_n\}$, each of which has a finite domain of possible values, D_i . A solution to L is an instantiation of all of the variables in Δ such that all of the constraints in C are satisfied.

We used the Choco CP library [13] to solve CSP. Choco aims to minimize or maximize the value of a single variable, while respecting a CSP definition. To do this, it uses an exhaustive search based on a depth-first search. We used two CSPs to resolve the software consolidation problem. The first CSP was used to determine the minimum number of VMs n_{new} needed to run all software; we call this the *MinVMToUse* problem. But n_{new} can be provided by several configurations (software mapping onto VMs). Therefore, the second CSP chooses the appropriate configuration and generates the reconfiguration plan to reach that configuration; this is called the *RightConfiguration* problem. We modeled these problems as a mixed-integer non-linear optimization problem. The

inputs are a list of VMs with their total resources, a list of software (for each VM) with their current resource quota and status (service level they provide).

The co-location of applications is defined by the SaaS provider. The co-location constraints are obtained using calibration and benchmark tests. The calibration can be automated using self-benchmarking tools (e.g., CLIF [15]).

2.2.1. The MinVMToUse problem

If no software deployment request has been submitted, the number of VMs in use after application of the *ConsolidationManager* should decrease or remain the same. This should be done while avoiding resource over commitment. This is expressed in the following inequality:

$$\sum s_j^{u,cur} \leq vm_i^u \wedge \sum s_j^{m,cur} \leq vm_i^m \wedge \sum s_j^{o,cur} \leq vm_i^o, \quad (1)$$

where $s_j^{vm} = i, \quad \forall VM \quad vm_i$.

We also allow the user to specify co-location requirements for each software. The following equation expresses that:

$$|s_i^{vm} - s_j^{vm}| + Col(s_i, s_j) \neq 0, \quad \forall \text{ pair of software } (s_i, s_j), \quad (2)$$

$i \neq j$

$$\text{where } Col(s_i, s_j) = \begin{cases} 1 & \text{if } s_i \text{ and } s_j \text{ are collocate-able} \\ 0 & \text{otherwise} \end{cases}$$

The variable X minimizing the number of VMs is defined as follows:

$$X = \sum ((len(vm_i) == 0) ? 0 : 1). \quad (3)$$

2.2.2. Speeding up the consolidation process

We made some improvements to the consolidation process to reduce the solver execution time. First, we reduced the search domain for X by bounding it. In the best case, the minimum number of VMs is the sum of the resource quotas needed by all the software divided by the resource capacity of the biggest VM (we choose the most restrictive resource type). In the worst case, there will be no consolidation. This improvement is formalized as follows:

$$\max \left(\left\lceil \frac{\sum s_i^{u_{cur}}}{\max(vm_j^u)} \right\rceil, \left\lceil \frac{\sum s_i^{m_{cur}}}{\max(vm_j^m)} \right\rceil, \left\lceil \frac{\sum s_i^{o_{cur}}}{\max(vm_j^o)} \right\rceil \right) \leq X \leq n, \quad (4)$$

where n is the current number of VMs.

Second, some VMs or software may be equivalent in terms of resources or co-location constraints. If the resources offered by a VM, vm_i , are insufficient to host software s_j , then they are also insufficient to host any software s_k which has the same requirements. In addition, software s_j cannot be hosted by any other VM vm_k having the same characteristics as vm_i . With regard to the co-location constraint, if a VM, vm_i , runs software s_j which cannot be collocated with software s_k , then vm_i cannot host any software of the same type as s_k .

2.2.3. The RightConfiguration problem

For correct configuration, the solver only considers configurations using the number of VMs determined by the first problem. The reconfiguration operation likely to affect the software SLA is live migration. The impact of this process could be a degradation of the service offered by the migrated software. Three factors affect live migration: network utilization, remaining computation power on both source and destination VM, and efficiency of the implementation of the live migration itself. Considering this, we call s_i^f the function calculating the impact of migrating software s_i for a given triplet of factors. Thus, if s_i^e represents the current service level provided by s_i before migration, then $s_i^e s_i^f$ is the service level during migration. We define the cost of migrating a software s_i as $s_i^A = s_i^e - s_i^e * s_i^f$. The correct configuration is the one minimizing K ,

$$K = \sum s_i^A, \quad \forall \text{ software } s_i \text{ to be migrated} \quad (5)$$

while avoiding SLA violations:

$$s_i^e * s_i^f < s_i^T, \quad \forall \text{ software } s_i \text{ to be migrated.} \quad (6)$$

3. Use cases

This work was conducted conjointly with two industrial groups: Scale Agent and Eolas. The former provides an implementation of the JMS specification, while the latter is an SaaS provider offering Internet services. We used our solution to manage an SaaS offering both a messaging service (such as IronMQ [16] and AmazonSQS [17]) provided by Joram [18] software, and an Internet service based on a LAMP architecture. This section presents the two use cases and the migration algorithms implemented. Migrating a running software serving requests (which is the case for both JMS and Internet servers) raises two main challenges that we had to address:

- (C1) Avoid loss of requests and state during migration.
- (C2) Make the migrated software available and accessible on the destination node after migration. This should be transparent for the clients.

3.1. JMS messaging servers

3.1.1. Overview of the messaging software Joram

Joram incorporates a 100% Java implementation of JMS 1.1 (Java Message Service) specification. It provides access to a truly distributed MOM (Message Oriented Middleware). Messages are handled through specific data structures called destinations: queue and topic. Fig. 4 presents how an application based on Joram functions. To build a Joram application, the first step is to create destinations, references of which must then be registered to a

directory (commonly the JNDI). Destinations are hosted by Joram servers, and accessible using their IP addresses or DNS names. For our use case, we assume that clients only use the DNS name of the Joram servers in interactions. All Joram servers are accessible via another Joram server. This ensures that all messages will be delivered within a given time even when the destination server is out for a short time. This creates an automatic recovery feature for Joram applications.

3.1.2. Live migration of a Joram server

Joram ensures that any message will reach its addressee within a configurable time window. We relied on this feature to complete the initial part of the first challenge (C1). For the second part of (C1), at runtime a Joram server keeps a persistence basis containing its entire state: processing messages, messages in transit, and processed messages. Therefore, a Joram server can be made available with the same state on the destination node by copying this basis from the source node to the destination node. With regard to (C2), in contrast to live migration of VMs, where the migrated VM keeps its IP address on the destination node, migrating software results in a new IP address (the IP address of the destination node). How can remote clients be transparently informed of this new address? In our system this is resolved by forcing clients to use the DNS name when dealing with the Joram servers. Thus, the accessibility of the migrated server is provided by (1) dynamically updating the DNS server and (2) rebinding the JMS client to the DNS server. This is transparent to the client because the JMS client is implemented to automatically resolve new addresses after several attempts. Algorithm 2 summarizes the live migration process described above, the “naive” migration algorithm. As we show in the evaluation (Section 4.2), immediate copy of the persistence basis can have an important impact on the service offered by the migrated Joram server when this file is very large. To avoid this problem, we have optimized the algorithm to transmit the log file block by block to the destination node (Algorithm 3). This optimization was inspired by the copy-on-write mechanism used for live VM migration. We customized the Joram implementation to dynamically integrate and evolve its state at runtime when receiving new persistence information. A timer, which is triggered at the beginning of the migration process, ends the copy to limit the duration of the whole process. This optimization is currently being integrated into the official implementation of Joram on the OW2 [18] open source platform.

3.2. LAMP servers

3.2.1. Overview

Many Internet services provided in the cloud are based on a LAMP architecture. This is a set of Linux machines running Apache/PHP servers linked to MySQL databases. Eolas SaaS is based on this architecture. In addition to this architecture, it uses a HAProxy loadbalancer in front of Apache servers when several Apache servers are needed. The MySQL-Proxy loadbalancer is also used in front of a set of MySQL database servers. To cope with sessions lost when an Apache server fails, Eolas stores all user sessions on an NFS server. Our second use case follows this architecture, as summarized in Fig. 5.

3.2.2. Live migration of LAMP servers

We present only the migration algorithm for the Apache server. [19] proposes a live migration algorithm for MySQL servers which could be easily integrated into our solution. It must be remembered that all Apache sessions are stored on the NFS server; this facilitates conservation of its state after migration. The migration process is summarized by Algorithm 4.

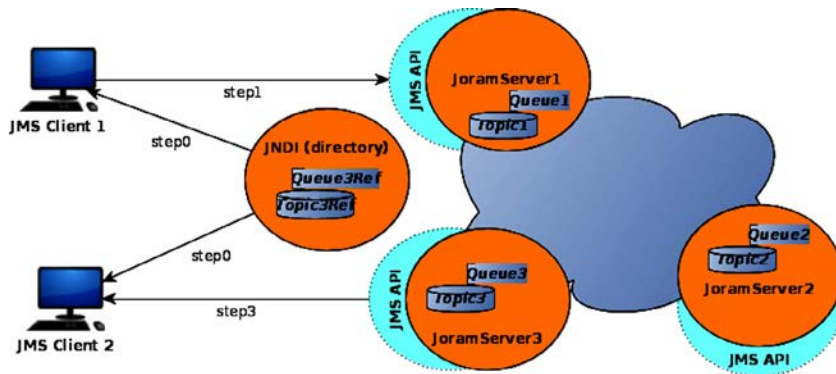

Fig. 4. Basic functioning of an application running on Joram servers.

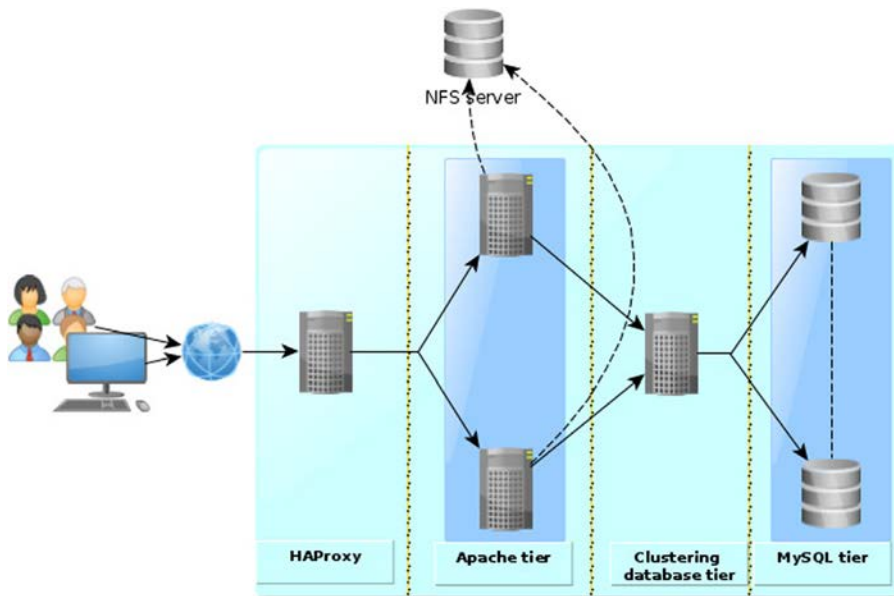

Fig. 5. The architecture of our Internet application.

Symbols:

- vm_{src} : The source VM
- vm_{dest} : The destination VM

Begin

1. Stop the software on vm_{src}
2. Copy the Joram persistence basis
3. Start the software on vm_{src} . Apply the state included in the persistence basis
4. Update the DNS server

End

Algorithm 2: Live migration of a Joram server (Naive)

Symbols:

- vm_{src} : The source VM
- vm_{dest} : The destination VM

Begin

1. Reconfiguration and reloading of the NFS server to make the session folder accessible by vm_{dest}
2. Mount the NFS session folder on vm_{dest}
3. Configure and start Apache on vm_{dest}
4. Reconfigure and reload HAProxy (hot reload) so that it considers the Apache on vm_{dest}
5. Stop Apache on vm_{src} when it has no requests in execution

End

Algorithm 4: Live migration of an Apache server

Symbols:

- As in Algorithm 2

Begin

1. Stop the software on vm_{src}
2. Copy the first block of the Joram persistence basis
3. In background, launch copy of the remaining persistence basis block per block.
4. Start the software on vm_{src} . This instance will dynamically update its state according to the receiving block.
5. Update the DNS server.

End

Algorithm 3: Optimization of Algorithm 2

4. Evaluations

We evaluated our solution to show the benefits of software consolidation on top of VM consolidation. These benefits are shown in terms of energy and cost savings. The efficiency and scalability of CSP-based consolidation methods were evaluated in [6,19]. As mentioned in the previous section, the SaaS we considered offers two applications: a JMS messaging application (with Joram) and a web application (with LAMP). Before assessing the energy and cost savings, we first evaluated the migration algorithms implemented for the different software.

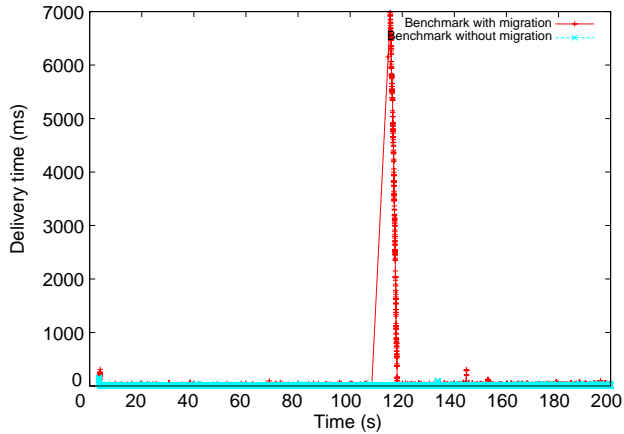

Fig. 6. Impact of migrating a Joram server.

4.1. Testbed overview

4.1.1. The cloud infrastructure

The cloud testbed integrates both a private and a public platform. Our private cloud is a part of the Eolas data center. It is composed of 8 DELL PowerEdge R510 equipped with Xeon E5645 2.40 Ghz processors (one with a 12-core CPU, and the others with 8-core CPU), 32 Gb memory and 2 NICs at 1 Gbps. They are connected through a gigabyte network switch. The virtualized layer is provided by VMware vCenter 5.1.0 (ESXi 5) with the VM consolidation module DRS/DPM [20] enabled: a PM for the vCenter, a PM with an NFS server to host VM images and user sessions, and 5 PMs as ESXi to host VMs. The last PM hosts our system (including the DNS server) and the agents simulating the Joram and web server users. The cloud provides a single type of VM: 1 vcpu running at 2.4 GHz and 1 Gb memory. The public used was Amazon EC2 in the M1, medium VM, configuration.

4.1.2. Benchmarks

SPECjms2007 [11] was used to bench the Joram servers. SPECjms2007 is the industry-standard benchmark for evaluating the performance of enterprise MOM servers based on JMS. SPECjms2007 models the supply chain for a chain of supermarkets. The scenario offers a natural scaling of the workload, e.g. by adjusting the number of supermarkets (horizontal) or by adapting the number of products sold per supermarket (vertical). Its configuration parameter *base* sets the scalability factor. The scenario includes seven interactions. Each interaction can use several types of destinations (queues or topics) and run over several steps. A scenario is organized in 3 phases: warm-up period (scaling up), measurement period (constant message injection), and drain period (last messages treated before the end of the benchmark). SPECjms2007 defines the SLA for this scenario as follows: 90% of messages should be delivered within 5 s. For our experiments we used vertical scalability with *base* configured to 26 (generating up to 135 destinations). For each type of interaction, a single Joram server hosts all of its destinations. Thus, 7 servers are needed to run a scenario. Among these servers, we consider the one hosting destinations for the statistics interaction (the HQ_SMStatsQ queue) as the most representative (hereafter called the indicator) for a scenario. This server is, in fact, the most solicited. Accordingly, only the results relating to the HQ_SMStatsQ destination will be presented. To simplify reading, we express a scenario as follows: warm-up#measurement#drain#nbOfVMUsed. For all experiments, each Joram server was configured to use one-tenth of a VM as the minimum quota and a quarter as the maximum.

The second use case was based on real traces of the Internet service offered by the Eolas SaaS. We played the traces with

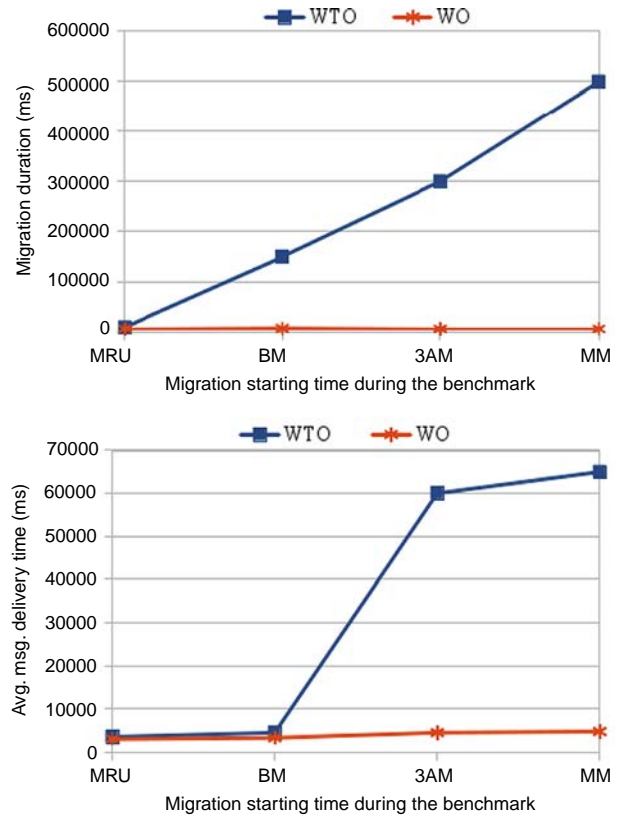

Fig. 7. Comparison of the naive and the optimized migration algorithms.

the Neoload [21] load injector toolkit to submit the workload to our LAMP servers. However, a synthetic load profile was used to evaluate the impact of migration. Traces were only used for the overall evaluation.

4.2. Impact of migrating a Joram server

To evaluate the impact of migrating a Joram server, we ran a set of experiments (on both a private and a public cloud) with two scenarios 300#1200#0#2: one requiring migration and the other without migration. Migration consists of moving an indicator from vm_1 to vm_2 . Although the non-migrated Joram servers on the source and destination VMs were not affected by the migration, the migrated server was degraded during the migration, as shown in Fig. 6. Thus, message delivery time on the HQ_SMStatsQ destination was adversely affected by migration on the private cloud using the “naive” algorithm, with messages being delivered within about 7 s during migration while the migration itself takes about 8 s.

The benefit of the optimization of the migration algorithm was evaluated by running the same experiment with optimization (WO) and without optimization (WOO) while varying the migration time (which implies copying different Joram server log file sizes). The process was assessed in the middle of the ramp-up period (MRU), at the beginning of the measurement period (BM), 3 min after the measurement period (3AM), and in the middle of the measurement period (MM) (Fig. 7). Varying the migration time during the experiment reveals how the two algorithms cope with the increasing size of the migrated Joram server log file. The top panel shows the duration of the migration process while the lower panel shows the average delivery time for messages during the migration. We can see that the optimized algorithm results in an almost constant migration duration whereas the naive algorithm results in an exponential increase in duration of migration. This is caused by the fact that the migrated Joram server has to load its

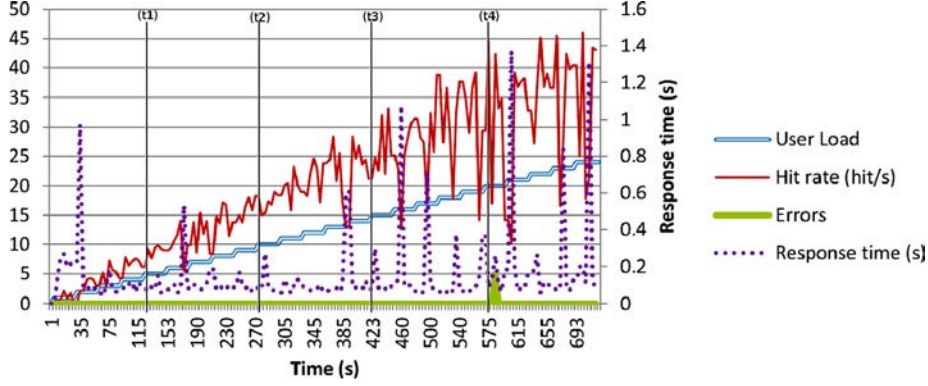

Fig. 8. Impact of migrating an Apache server while simultaneously increasing the number of internet users.

entire state (the log file) at start time (on the destination VM) with the naive algorithm. The time needed to load this state increases with the size of the log file. This phenomenon is avoided by the optimized algorithm since logs are transmitted and loaded block by block. These experiments also show that neither of the migration algorithms leads to message losses, or state loss. The optimized algorithm always respects the SLA, since the number of messages delivered after longer than the prescribed time is negligible throughout the scenario. This is not always the case with the naive algorithm where the number of delayed messages increases with the size of the log file. Running these scenarios on Amazon EC2 produced similar results, although the peak for the average delivery time was higher.

4.3. Impact of migrating an Apache server

To evaluate the impact of migrating an Apache server, we ran a set of experiments with different workloads. The migration consists of moving the Apache server from its initial VM to another VM (in our case the VM running the MySQL server). It must be remembered that taking the new location of the migrated Apache server into account requires reconfiguration and the reloading of the HAProxy loadbalancer. This is the most crucial step because no requests can be treated by the application during reloading. This could lead to lost requests. We performed a set of experiments while varying the number of Internet users to see if the number of requests lost depended on the workload (Fig. 8). These results show that with up to 25 simultaneous users (time t1, t2, and t3) no requests are lost during migration. The consolidation algorithm can be configured so that the system will discard migrations where requests have been lost. This strategy has been applied for the remainder of the experiments described here. Fig. 8 also shows that migration does not affect the application's throughput or response time. Throughout the experiment, the migration time is almost constant, at about 40 s.

4.4. Power saving in the private cloud

4.4.1. Formalization

Software consolidation packs software onto a minimum number of VMs and terminates free VMs. This gives a greater VM consolidation capacity in the virtualization layer. Thus, if combined with a VM consolidation mechanism such as [6] or VMware DRS/DPM [20], the cloud infrastructure could turn off some PMs to reduce power consumption. The following linear power consumption model of a PM at time t is widely used in the literature [22]:

$$P_i(U_i(t)) = P_i^{\min} + (P_i^{\max} - P_i^{\min}) * U_i(t) \quad (7)$$

$$E = \sum E_i, \quad \text{where } E_i = \int_0^t P_i(U_i(x)) dx \quad (8)$$

P_i^{\max} is the maximum power consumed by a PM when it is fully used, P_i^{\min} is the power consumption when it is idle, and U_i is the CPU utilization level. E is the total energy consumed by the cloud infrastructure. $P_i(U_i(t))$ increases with $U_i(t)$, which depends on the number of VMs and software applications running on the PM:

$$U(t) = \sum_{i=1}^{\text{len}(PM_k)} P(vm_i) \quad (9)$$

with

$$P(vm_i) = \sum_{j=1}^{\text{len}(vm_i)} s_j^{ut} + \Omega, \quad \text{such that } s_j^{vm} = i \quad (10)$$

$\text{len}(PM_k)$ is the number of VMs on PM_k , and Ω is the VM overhead. According to Eq. (9), relocating a service from one VM to another VM is beneficial in terms of reducing power consumption when it leads to a VM termination. In the worst case, this gain is

$$\int_0^t (P_i^{\max} - P_i^{\min}) * \Omega dx \quad (11)$$

in the best case (the VM running alone on its PM), it is the power consumed by a PM which can be stopped.

The benefit of reducing the number of VMs from n to n' is given by the following formula:

$$\sum_{i=1}^{nbPM - nbPM'} E_i + (n - n') \int_0^t (P_i^{\max} - P_i^{\min}) * \Omega dx \quad (12)$$

where E_i is the power which would have been consumed by the PM P_i if not switched off; $nbPM$ and $nbPM'$ are, respectively, the number of PMs used to host n and n' VMs.

4.4.2. Evaluation results

We simultaneously ran 15 SPECjms2007 and 6 LAMP scenarios (up to 37 VMs) in two situations. In the first situation (noted WSC (With Software Consolidation)) we ran the experiment with both software and VM consolidation enabled, while in the second situation (noted WOSC (WithOut Software Consolidation)) we disabled software consolidation (but maintained VM consolidation). The scenarios were configured to provide a varied workload over 30 h: a mix of constant, ascending and descending phases. Fig. 9 presents (1) the occupancy (in terms of the number of VMs) of each PM in the private cloud, and (2) the number of PMs in use during the 25 h of observation. We see that the first situation results in 3 PMs (PM2, PM3 and PM5) being freed, while 1 PM (PM2) was freed in the second situation. As formalized in the previous section, software consolidation definitively accelerates VM consolidation. The bottom right curve in Fig. 9 shows that this improvement represents an approximately 40% power saving with this particular workload.

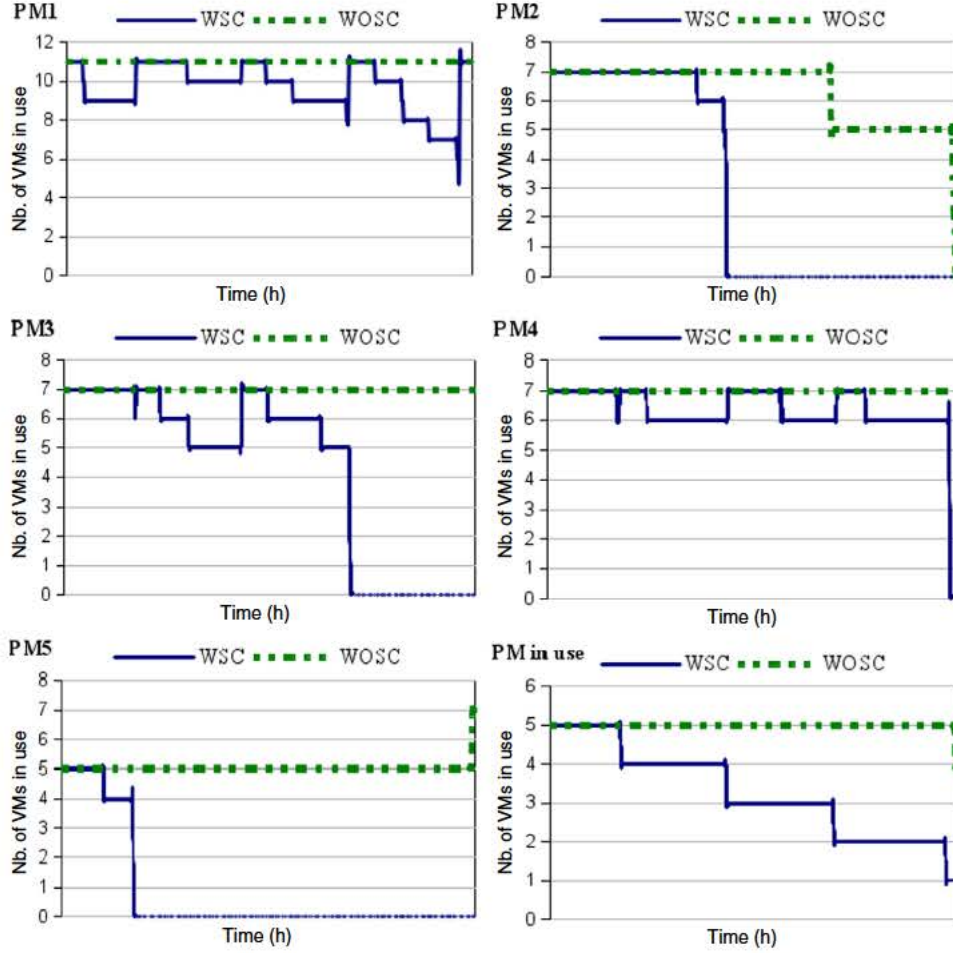

Fig. 9. Power saving in the private cloud: Utilization of PMs.

4.5. Cost saving in a public cloud

4.5.1. Formalization

When relying on a commercial cloud, the SaaS provider is charged as a function of the total number of VMs used. Therefore, minimizing the invoice is equivalent to the MinVMToUse problem. The cost of using the public cloud at time $t\theta$ is given by $TotalCost(t\theta)$. Let $Old_{(t-1)\theta}$ be the list of VMs existing since time $(t-1)\theta$, $New_{(t-1)\theta}$ be the list of new VMs started after time $(t-1)\theta$ but before $t\theta$, and

$$Cost(listOfVMs) = \sum_{i=1}^{len(listOfVMs)} vm_i^y \quad (13)$$

be the cost of running the list of VMs, $listOfVMs$, for the payment time unit θ . Then

$$Cost_{t\theta} = Cost(Old_{(t-1)\theta} \cup New_{(t-1)\theta}) \quad (14)$$

with $Old_0 = \emptyset$,

$New_0 = \{\text{the set of VMs started for the first time by the cloud}\}$
Therefore

$$TotalCost_{t\theta} = \sum_{i=1}^t Cost_{i\theta} \quad (15)$$

$Cost_{t\theta}$ is the additional cost of using the cloud from time $(t-1)\theta$ to time $t\theta$. This cost is kept to a minimum since $Old_{(t-1)\theta} \cup New_{(t-1)\theta}$ is minimized by the MinVMToUse problem. Therefore, $TotalCost_{t\theta}$ is the minimum cost of using the cloud at time $t\theta$.

4.5.2. Evaluation results

We repeated the previous experiments on the private cloud with VMs configured to run for an hour (before termination because they were empty) on Amazon EC2. We used M1, medium VMs instances, which are charged at \$0.120 per VM per hour. Fig. 10 presents the total number of VMs used over the 25 h of observation, and the total cost of the experiments. The number of VMs is seen to drastically decrease thanks to software consolidation, resulting in an approximate 40.5% saving: from about \$1300 (without software consolidation) to \$800 (with software consolidation).

5. Related work

Memory footprint improvements. Significant research has been devoted to improving workload consolidation in data centers. Some studies have investigated reducing the VM memory footprint to increase the VMs' consolidation, when a VM is dedicated to a single software. Among these, memory compression and memory over commitment [23–26] are very promising. In the same vein, [27] extends the VM ballooning technique to software to increase the density of software collocation on the same VM; [28] presented a similar approach. [29] presented VSwapper, a guest-agnostic solution to reduce the effect of memory ballooning. Another study, [30], presents an energy-aware workload consolidation framework at the kernel level. The power and performance prediction models presented in this work were used to consolidate a set of processes as a single Graphic Processing Unit (GPU) workload. Xen offers

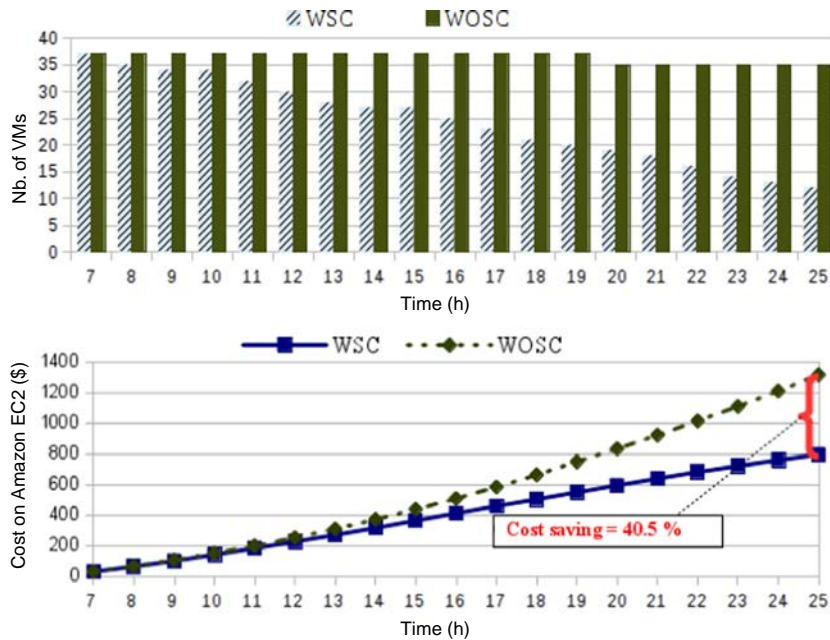

Fig. 10. Cost saving on Amazon EC2: (top) nb. of VMs per hour, (bottom) VMs charged.

what is called “stub domain”.² This is a lightweight VM which requires very few memory (about 32 MB) for its execution. As our solution, all these works try to minimize the footprint of a VM in order to increase the number of VMs that can be collocated on top of the same physical machine. Therefore, they result to the same result in terms of energy saving. However, they do not minimize the total number of VMs as we do in order to reduce VMs charged for the clients when considering of a commercial cloud.

Impact of VM consolidation. Several research [31,32] have investigated the impact of consolidating several VMs on top of the same host. This situation leads to resource contention/interference which is the main origin of performance degradation. [33] studies the problem by characterizing workloads which can be collocated without enough interference. [34] studied interference when collocating MapReduce applications. It proposes a tasks scheduling strategy based on a performance prediction model in order to minimize the impact of co-locating competitive tasks. [35] studied the effects of collocating different types of VMs under various VM to core placement schemes in order to discover the optimal placement for performance. We perform in this paper a number of experiments in the same direction. [36] proposed a software probe for detecting contention because hardware platform specific counters (usually used) are not always sufficient. [37] characterized IO performance to study the impact of collocating several software applications running on separate VMs on the same PM. The conclusion of this paper is useful for users of our framework since it could be used to define collocate-able software. [35] also studied the impact of collocating VMs on the same PM and proposed an interference metric and regression model. Along the same lines, [38] motivated the need to study workload consolidation and provided a VM consolidation framework. The objective of their system was to organize all the VMs (or sets of users) in the cloud in terms of groups of VMs that can share the same PM with negligible interference. [39] analyzed the trace of a real data center and proposed a workload consolidation algorithm which avoids collocation of non-collocate-able software on the same PM. Its consolidation algorithm also avoids SLA violations when a peak load

occurs during migration. This was feasible in [39] because it studied a trace. [40] presents a technique to predict performance interference due to sharing a processor cache. This technique works on current processor architectures and predicts degradation for any possible placement. It can therefore be used to select the most efficient consolidation pattern. The solution presented here takes the impact of consolidation into account by organizing software which would severely compete for the same resources. The solution we present in this paper takes into consideration the impact of consolidating competitive workload onto the same VM. The responsibility is given to the provider. Recall that we consider in this paper SaaS hosting centers. In this context, the provider well knows the applications he provides. Thus, he knows (e.g. through experiments) which application or part of an application can be collocated with which one, knowing that our solution provides a way to consider these constraints.

VM consolidation algorithms. The research community made an important contribution to workload consolidation through VM consolidation using various heuristic algorithms. In our previous work [5], we proposed a couple of this sort of VM relocation and collocation algorithms. Likewise, [41] proposed a simple VM consolidation algorithm which is similar to the First-Fit Decreasing (FFD) heuristic [42], while [43] customized the FFD algorithm to integrate the cost of live VM migration. [44] studied a set of heuristics algorithms and proposed new versions of heuristics when the VM migration cost was taken into account. In these new versions, several experiments on real workloads were performed. [45] presented a VM consolidation framework considering cpu, memory, and IO resources. Its collocation algorithm also considered network communication intensity between VMs, and PM temperature. The VM placement algorithm, a heuristic bin-packing algorithm, is not described. The network communication intensity described by Beloglazov et al. [45] could be integrated into our framework, but the temperature monitor is not feasible since we do not measure the PM temperature. [46] presents an adaptive heuristic for VM consolidation based on analysis of past VM resource usage. A set of formalizations for the VM placement problem is also provided. [47] also treats the VMs consolidation problem using a heuristic algorithm which minimizes the number of live migrations in the reconfiguration

² <http://wiki.xen.org/wiki/StubDom>.

plan. An SLA-aware VMs consolidation system is presented in [41]. Like with our proposal, it formalizes the problem of minimizing the operating cost for a private cloud while also minimizing SLA violations for services offered by software. Our formalization can be extended by considering this work. [48] presents an energy-aware VM placement and a consolidation algorithm. These are specific to the snooze cloud platform [48]. The consolidation algorithm is restricted to use in a homogeneous environment and reuses elements from [47]. [49] consolidates tasks onto VMs using a First-Fit algorithm. Only the basic formalization of the problem is described, and no details are given about the system. [50] presents a VM consolidation strategy based on a predictive approach. Since the placement problem is NP-hard, it is not possible to develop a solution running within an acceptable time. [51] presents DejaVu, a consolidation system which takes into consideration the interference between consolidated VMs. Based on hardware counters, it proposes a metric for characterizing workloads which are collocatable. In this paper, we do not focus on VM consolidation. We bring the same idea at software level (software within VMs). Therefore, any VM consolidation algorithm presented in this section can be applied to software consolidation. In this paper, we base on a solver to resolve the problem.

Software consolidation. The main problem with previous solutions is that they are limited by the footprint of the VMs consolidated (they are all operating systems). Execution of a VM requires a set of minimum resources, even if the application it runs is idle. Thus, we propose a solution which dynamically packs software into VMs to effectively use the overall VM resources while respecting the individual requirements of the different software applications. With current knowledge, [19] is the only previous work that studies dynamic software consolidation on the same OS; however, it does not rely on VMs. [19] focuses on the MySQL database software and provides a live migration algorithm for that. This algorithm can be plugged into our framework. [19] (as well as Entropy [6]) describes a consolidation algorithm based on a Constraint Satisfaction Problem (CSP) [14]. Thus, no previous study has investigated software consolidation onto VMs. In this paper, we developed a working prototype and showed that it can achieve high VM utilization to provide cost- and power-saving benefits.

6. Discussion

The work presented in this paper does not re-invent the wheel. We propose an effective transposition of VM consolidation (a widely and commonly approved solution for energy saving in a IaaS) into software consolidation. In addition to energy saving, we show how this solution can be benefited (in terms of cost saving) for public cloud customers (clients). As we argued in the Introduction, a software collocation solution must provide isolation mechanisms, which are the main advantages of VMs. We claim in this paper that in some situations, the need of a full/strong isolation as provided by VMs is not necessary. Some lightweight solutions such as cgroup or chroot are sometimes sufficient. For instance, when we consider a SaaS hosting center where the provider well knows applications and is the only manager of the infrastructure, the probability to have troubleshooting coming from outside or from VMs is minimized. In this context, consolidating software on top of the same VM makes sense. Combining this with a traditional VM consolidation system will increase the number of powered-off machines (which leads to energy saving). Another use case concerns enterprises or individual users who want to deploy their application within a public commercial cloud. In this context, they need to minimize their VMs charged. This is achieved by reducing the number of active VMs. As for a SaaS provider, the enterprise or the individual user can rely on our solution to do that.

Live migration is another important mechanism that should be offered in order to support dynamic software consolidation. This could be considered (in point of view of the user of our framework) as the main drawback of our solution since it requires the user to provide for each application component the implementation of its live migration. This paper presents various live migration implementations for JMS (integrated within Joram [18] development branch and being tested for the coming release) and Internet services, which are among the most deployed applications on the internet. Also, the framework we introduce in this paper is built such a way that the integration of new live migration implementations (according to the considered applications) is facilitated. Evaluations results we have obtained both in our private cloud and Amazon EC2 show the viability of our solution.

7. Conclusion

In this paper we proposed a solution to consolidate software onto VMs to reduce power consumption in a private cloud and the number of VMs charged for in a public cloud. We focused on the algorithms for live migration and consolidation. Although the proposed solution can integrate other live software migration algorithms, we demonstrated that the algorithms were efficient for JMS messaging and web servers. The consolidation algorithm was inspired by Entropy, which treats VM consolidation based on a Constraint Satisfaction Problem (CSP) approach. Evaluations with realistic benchmarks on a messaging and web applications SaaS cloud showed that our solution (1) reduces the power consumed by our industrial cloud partner by about 40% when combined with VM consolidation, and (2) reduces the charge for VMs used on Amazon EC2 by about 40.5%. Future work will include extended analysis of how best to coordinate software consolidation on VMs with VM consolidation on physical machines in order to further improve power gains.

Acknowledgments

This work is supported by the French Fonds National pour la Societe Numerique (FSN) and Poles Minalogic, Systematic and SCS, through the FSN Open Cloudware project.

References

- [1] Jonathan Koomey, Growth in data center electricity use 2005 to 2010, A report by Analytics Press, completed at the request of The New York Times, August 2011 in <http://www.analyticspress.com/datacenters.html> (visited on April 2013).
- [2] Ozlem Bilgir, Margaret Martonosi, Qiang Wu, Exploring the potential of CMP core count management on data center energy savings, in: 3rd Workshop on Energy Efficient Design 2011.
- [3] Inkwon Hwang, Massoud Pedram, othy Kam, A study of the effectiveness of CPU consolidation in a virtualized multi-core server system, in: ISLPED 2012.
- [4] RightScale Cloud Management, in www.rightscale.com/ (visited on April 2013).
- [5] Alain Tchana, Giang Son Tran, Laurent Broto, N. De Palma, Daniel Hagimont, Two levels autonomic resource management in virtualized IaaS, in: FGCS 2013.
- [6] Fabien Hermenier, Xavier Lorca, Jean-Marc Menaud, Gilles Muller, Julia Lawall, Entropy: a consolidation manager for clusters, in: VEE 2009.
- [7] Zhenhuan Gong, Xiaohui Gu, PAC: Pattern-driven application consolidation for efficient cloud computing, in: MASCOT 2010.
- [8] Hui Lv, Yaozu Dong, Jiangang Duan, Kevin Tian, Virtualization challenges: a view from server consolidation perspective, in: VEE 2012.
- [9] C. Norris, H. M. Cohen, B. Cohen, Leveraging ibm ex5 systems for breakthrough cost and density improvements in virtualized x86 environments, January 2011 (white paper) in <ftp://public.dhe.ibm.com/common/ssi/ecm/en/xsw03099usen/XSW03099USEN.PDF>.
- [10] Docker: www.docker.com (visited on September 2014).

[11] SPECjms2007: industry-standard benchmark for evaluating the performance of enterprise message-oriented middleware servers based on JMS, in <http://www.spec.org/jms2007/> (visited on April 2013).

[12] A. Karve, T. Kimbrel, G. Pacifici, M. Spreitzer, M. Steinder, M. Sviridenko, A. Tantawi, Dynamic placement for clustered web applications, in: WWW 2006.

[13] N. Jussien, G. Rochart, X. Lorca, The CHOCO constraint programming solver, in: OSSICP 2008.

[14] Frédéric Benhamou, Narendra Jussien, Barry O'Sullivan, Trends in constraint programming, in: ISTE 2007.

[15] CLIF: <http://clif.ow2.org/> (visited on September 2014).

[16] IronMQ: The Message Queue for the Cloud, in <http://www.iron.io/mq> (visited on April 2013).

[17] Amazon Simple Queue Service (Amazon SQS), in <http://aws.amazon.com/sqs/> (visited on April 2013).

[18] JORAM: Java (TM) Open Reliable Asynchronous Messaging, in <http://joram.ow2.org/> (visited on April 2013).

[19] Carlo Curino, Evan P.C. Jones, Samuel Madden, Hari Balakrishnan, Workload-aware database monitoring and consolidation, in: SIGMOD 2011.

[20] VMWare Distributed Power Management (DPM), Technical White Paper, 2010 in <http://www.vmware.com/files/pdf/DPM.pdf>.

[21] Neotys, NeoLoad: load test all web and mobile applications, 2012, October in <http://www.neotys.fr/>.

[22] Anton Beloglazov, Jemal H. Abawajy, Rajkumar Buyya, Energy-aware resource allocation heuristics for efficient management of data centers for Cloud computing, *Future Gener. Comput. Syst.* 28 (5) (2012).

[23] Prateek Sharma, Purushottam Kulkarni, Singleton: System-wide page deduplication in virtual environments, in: HPDC 2012.

[24] Diwaker Gupta, Sangmin Lee, Michael Vrable, Stefan Savage, Alex C. Snoeren, George Varghese, Geoffrey M. Voelker, Amin Vahdat, Difference engine: harnessing memory redundancy in virtual machines, *Commun. ACM Mag.* 53 (10) (2010).

[25] Sean Barker, Timothy Wood, Prashant Shenoy, Ramesh Sitaraman, An empirical study of memory sharing in virtual machines, in: USENIX ATC 2012.

[26] Lanzheng Liu, Rui Chu, Yongchun Zhu, Pengfei Zhang, Liufeng Wang, DMSS: A dynamic memory scheduling system in server consolidation environments, in: ISORC 2011.

[27] Tudor-Ioan Salomie, Gustavo Alonso, Timothy Roscoe, Kevin Elphinstone, Application level ballooning for efficient server consolidation, in: EuroSys 2013.

[28] Soramichi Akiyama, Takahiro Hirofuchi, Ryousei Takano, Shinichi Honiden, MiyakoDori: A memory reusing mechanism for dynamic VM consolidation, in: CLOUD 2012.

[29] Nadav Amit, Dan Tsafir, Assaf Schuster, VSwapper: A memory swapper for virtualized environments, in: ASPLOS 2014.

[30] Dong Li, Surendra Byna, Srimat Chakradhar, Energy-aware workload consolidation on GPU, in: ICPPW 2011.

[31] Lingjia Tang, Jason Mars, Neil Vachharajani, Robert Hundt, Mary Lou Soffa, The impact of memory subsystem resource sharing on datacenter applications, in: ISCA 2011.

[32] George Kousiouris, Tommaso Cucinotta, Theodora Varvarigou, The effects of scheduling, workload type and consolidation scenarios on virtual machine performance and their prediction through optimized artificial neural networks, *J. Syst. Softw.* 84 (8) (2011).

[33] Younggyun Koh, Rob Knauerhase, Paul Brett, Mic Bowman, Zhihua Wen, Calton Pu, An analysis of performance interference effects in virtual environments, in: ISPASS 2007.

[34] Xiangping Bu, Jia Rao, Cheng-Zhong Xu, Interference and locality-aware task scheduling for MapReduce applications in virtual clusters, in: HPDC 2013.

[35] Indrani Paul, Sudhakar Yalamanchili, Lizy K. John, Performance impact of virtual machine placement in a datacenter, in: IPCCC 2012.

[36] Joydeep Mukherjee, Diwaker Krishnamurthy, Jerry Rolia, Chris Hyser, Resource contention detection and management for consolidated workloads, in: IM 2013.

[37] Ajay Gulati, Chethan Kumar, Irfan Ahmad, Storage workload characterization and consolidation in virtualized environments, in: VPACT 2009.

[38] Vatche Ishakian, Raymond Sweha, Jorge Londono, Azer Bestavros, Colocation as a service: Strategic and operational services for cloud colocation, in: NCA 2010.

[39] Akshat Verma, Gargi Dasgupta, Tapan Kumar Nayak, Pradipta De, Ravi Kothari, Server workload analysis for power minimization using consolidation, in: USENIX ATC 2009.

[40] Sriram Govindan, Jie Liu, Aman Kansal, Anand Sivasubramaniam, Cuanta: Quantifying effects of shared on-chip resource interference for consolidated virtual machines, in: SOCC 2011.

[41] Hadi Goudarzi, Mohammad Ghasemazar, Massoud Pedram, SLA-based optimization of power and migration cost in cloud computing, in: CCGRID 2012.

[42] Silvano Martello, Paolo Toth, *Knapsack Problems: Algorithms and Computer Implementations*, John Wiley & Sons, 1990.

[43] R. Suchithra, N. Rajkumar, Efficient migration—a leading solution for server consolidation, *Int. J. Comput. Appl.* 60 (18) (2012).

[44] Tiago C. Ferreto, Marco A.S. Netto, Rodrigo N. Calheiros, César A.F. De Rose, Server consolidation with migration control for virtualized data centers, *Future Gener. Comput. Syst.* 27 (8) (2011).

[45] Anton Beloglazov, Rajkumar Buyya, Energy efficient resource management in virtualized cloud data centers, in: CCGRID 2010.

[46] Anton Beloglazov, Rajkumar Buyya, Optimal online deterministic algorithms and adaptive heuristics for energy and performance efficient dynamic consolidation of virtual machines in cloud data centers, *Concurr. Comput. Pract. Exper.* 24 (13) (2012).

[47] Aziz Murtazaev, Sangyoon Oh, Sercon: Server consolidation algorithm using live migration of virtual machines for green computing, *IETE Tech. Rev.* 28 (3) (2011).

[48] Eugen Feller, Cyril Rohr, David Margery, Christine Morin, Energy management in IaaS clouds: A holistic approach, in: CLOUD 2012.

[49] Ching-Hsien Hsu, Kenn D. Slagter, Shih-Chang Chen, Yeh-Ching Chung, Optimizing energy consumption with task consolidation in clouds, in: IS, 2012, ISSN: 0020-0255.

[50] Jason Mars, Lingjia Tang, Robert Hundt, Kevin Skadron, Mary Lou Soffa, BubbleUp: increasing utilization in modern warehouse scale computers via sensible co-locations, in: MICRO 2011.

[51] Nedeljko Vasic, Dejan Novakovic, Svetozar Miucin, Dejan Kostic, Ricardo Bianchini, DeJaVu: Accelerating resource allocation in virtualized environments, in: ASPLOS 2012.



Alain Tchana received his Ph.D. in Computer Science in 2011, at the IRIT laboratory, Institute National Polytechnique de Toulouse, France. Since November 2011 he is a Postdoctoral at University of Grenoble (UJF/LIG). He is a member of the SARDES research group at LIG laboratory (UJF/CNRS/Grenoble INP/INRIA). His main research interests are in autonomic computing, Cloud Computing, and Green Computing.



Noel De Palma received his Ph.D. in Computer Science in 2001. Since 2002 he was Associate Professor in computer science at University of Grenoble (ENSIMAG/INP). Since 2010 he is professor at Joseph Fourier University. He is a member of the ERODS research group at LIG laboratory (UJF/CNRS/Grenoble INP/INRIA), where he leads researches on Autonomic Computing, Cloud Computing and Green Computing.



Ibrahim Safieddine is a Ph.D. student in ERODS team within the LIG (Laboratoire d'Informatique de Grenoble). His research interests are cloud computing, autonomic management systems and green computing.



Daniel Hagimont is a Professor at Polytechnic National Institute of Toulouse, France and a member of the IRIT laboratory, where he leads a group working on operating systems, distributed systems and middleware. He received a Ph.D. from Polytechnic National Institute of Grenoble, France in 1993. After a postdoctorate at the University of British Columbia, Vancouver, Canada in 1994, he joined INRIA Grenoble in 1995. He took his position of Professor in Toulouse in 2005.