



**HAL**  
open science

# Hardware-in-the-loop and Software-in-the-loop platform for test and validation of adaptable radio communications systems for railways at IP layer

Juan Moreno, Maha Bouaziz, Marion Berbineau, Ying Yan, José Soler, Raul Torrego, Val Inaki, Alessandro Vizzarri, Laurent Clavier, Rédha Kassi, et al.

## ► To cite this version:

Juan Moreno, Maha Bouaziz, Marion Berbineau, Ying Yan, José Soler, et al.. Hardware-in-the-loop and Software-in-the-loop platform for test and validation of adaptable radio communications systems for railways at IP layer. Net4Rails, May 2019, Colmar, France. 9p. hal-02531051

**HAL Id: hal-02531051**

**<https://hal.science/hal-02531051>**

Submitted on 3 Apr 2020

**HAL** is a multi-disciplinary open access archive for the deposit and dissemination of scientific research documents, whether they are published or not. The documents may come from teaching and research institutions in France or abroad, or from public or private research centers.

L'archive ouverte pluridisciplinaire **HAL**, est destinée au dépôt et à la diffusion de documents scientifiques de niveau recherche, publiés ou non, émanant des établissements d'enseignement et de recherche français ou étrangers, des laboratoires publics ou privés.



## Hardware-in-the-loop and Software-in-the-loop platform for test and validation of adaptable radio communications systems for railways at IP layer

**Moreno, Juan; Bouaziz, Maha ; Berbineau, Marion; Yan, Ying; Soler, José; Torrego, Raul; Iñaki, Val ; Vizzarri, Alessandro; Clavier, Laurent; Kassi, Rédha; Cocheril, Yann; Deniau, Virginie; Gransart, Christophe**

*Published in:*  
Proceedings of Net4Rails

*Publication date:*  
2019

*Document Version*  
Peer reviewed version

[Link back to DTU Orbit](#)

### *Citation (APA):*

Moreno, J., Bouaziz, M., Berbineau, M., Yan, Y., Soler, J., Torrego, R., ... Gransart, C. (2019). Hardware-in-the-loop and Software-in-the-loop platform for test and validation of adaptable radio communications systems for railways at IP layer. In Proceedings of Net4Rails

---

### General rights

Copyright and moral rights for the publications made accessible in the public portal are retained by the authors and/or other copyright owners and it is a condition of accessing publications that users recognise and abide by the legal requirements associated with these rights.

- Users may download and print one copy of any publication from the public portal for the purpose of private study or research.
- You may not further distribute the material or use it for any profit-making activity or commercial gain
- You may freely distribute the URL identifying the publication in the public portal

If you believe that this document breaches copyright please contact us providing details, and we will remove access to the work immediately and investigate your claim.

# Hardware-in-the-loop and Software-in-the-loop platform for test and validation of adaptable radio communications systems for railways at IP layer

Juan Moreno<sup>1</sup>, Maha Bouaziz<sup>2</sup>, Marion Berbineau<sup>2</sup>, Ying Yan<sup>3</sup>, José soler<sup>3</sup>, Raul Torregó<sup>4</sup>, Val Iñaki<sup>4</sup>, Alessandro Vizzarri<sup>5</sup>, Laurent Clavier<sup>6</sup>, Rédha Kassi<sup>6</sup>, Yann Cocheril<sup>2</sup>, Virginie Deniau<sup>2</sup>, Christophe Gransart<sup>2</sup>

<sup>1</sup> Área de Ingeniería, Metro de Madrid S.A., Madrid. juan.moreno@metromadrid.es

<sup>2</sup> University Lille Nord de France, IFSTTAR, COSYS, LEOST, Villeneuve d'Ascq, F-59650

<sup>3</sup> Technical University of Denmark, 2800 Kgs.Lyngby, Denmark

<sup>4</sup> IK4-Ikerlan Technology Research Centre, 20500, Arrasate-Mondragon, Spain

<sup>5</sup> Radiolabs, Consorzio Università Industria Laboratori di Radiocomunicazioni, Corso d'Italia  
19, 00198 Rome, Italy

<sup>6</sup> Univ. Lille, CNRS, UMR 8520 - IEMN, F-59000 Lille, France

**Abstract** this paper presents a description of a new emulation platform to help decrease expenses for the development of a new train-to-ground communication system for railways, which is one of the objectives of the Shift2Rail Joint Undertaking. This emulator will interface with the T2G communication prototypes at IP layer and will consider many railway-specific services, perturbations and physical layer scenarios. It will combine modern approaches for testing like hardware-in-the-loop and software-in-the-loop in order to mimic railways environment and radio access technologies on an efficient way. In this paper we explain all these aspects, beginning with the railway particular circumstances to be taken into account and ending with an explanation of the approach for the development of the emulator.

**Index Terms**—HITL, SITL, OAI, railways, train-to-ground communications, , wireless.

## 1 Introduction

Communication systems in railways last very long until they become obsolete but, on the other hand, also take a lot of time until they are developed, fully tested, validated and put into service. The reasons are many but the most important one is the presence of some railway-specific constraints like fragmentation in regulation, technical complexity, safety implications, *etc.* Shift2Rail JU [1], among its multiple objectives, has the development of a new adaptable train-to-ground (T2G) communications system able to overcome the limitations of the T2G communication systems available in the market, which are restricting the performance and evolution of some railway

services for train control and command like ETCS (European Train Control System) and CBTC (Communications-based Train Control). This new T2G system must be developed according to user requirements defined in the X2RAIL-1 project [2] and based on both NGTC [3] and FRMCS [4][5] specifications. Five key user requirements can be highlighted [2]:

- The system will be adaptable in terms of bearer selection and configuration as required by prevailing QoS demand and availability, and scale in terms of performance, reach and number of users.
- The network will provide a convenient means for migration, upgrade and maintainability, co-existence and backward compatibility when required.
- The network will be able to support safety-critical communication for railway applications, and be able to provide connectivity to selected third party users, such as primary emergency services.
- The system will be resilient to service disruption, for example, through equipment failure, malicious events, or interference.
- The system requirements should allow for the design of a system that lowers energy and environmental impacts when compared to existing solutions.

To avoid a costly and fragmented validation process including on site testing for this new adaptable T2G communication, the European EMULRADIO4RAIL Project [6] will provide an innovative emulation platform for tests and validation of various radio access technologies (RAT) like Wi-Fi, LTE, LTE-A, 5G and Satellites. The platform will combine simulations of the communication core network and emulation of various RAT thanks to the coupling of discrete event simulator such as RIVERBED Modeler (former OPNET Modeler) [7], Open Air Interface (OAI) [8], several radio channel emulators, models of IP parameters and real physical systems.

The project is an open call project in the Innovation Programme 2 of Shift2Rail. It is led by IFSTTAR with the participation of IKERLAN, DTU, Eurnex, RadioLabs, University of Lille and Metro de Madrid. The emulation platform will interface with different industrial prototypes of the new adaptable communication system at IP layer under development in the X2RAIL-3 project [9]. The testing scenarios will take into account many different railway-related services like ERTMS or CBTC, the influence of real environments based on radio channel emulation at Physical layer and also common perturbations present in railway scenarios (impulsive noises, potential jammers, *etc.*). Parts of the emulation platforms will take into account previous works done to evaluate railway communications in different context [10], [11].

The structure of this article is as follows: section II provides an overview of the different requirements for the emulation platform; in Section III the technical alternatives and the development process are explained and, finally, in Section IV the conclusions are drawn.

## 2 Requirements for the emulation tool

In this section we will explain the requirements for the emulation tool in three different categories: the Key Performance Indicators (KPI) that will perceive the railway services, the railway scenarios to be considered (this is, the channel models available in the literature that will be emulated using hardware channel emulators) and the potential perturbations to be injected. In Fig. 1 a general schematic of the architecture of the emulation platform is shown. PLMN stands for Public Land Mobile Network and SITL means System-In-The-Loop (SITL). The SITL module is a Riverbed module that interfaces simulations with real systems. It provides an interface for connecting live network hardware or software applications to a Riverbed discrete event simulation.

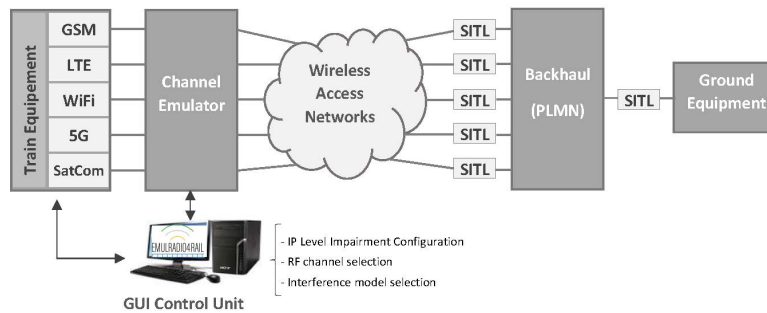

Fig. 1: Block diagram of the proposed emulation platform.

### 2.1 Services and radio access technologies

In railways, there are many different services and they are usually divided into three different categories: safety-critical, operator-oriented and passenger-oriented [2]. In the first type, we find transmission-based signaling systems like ETCS and CBTC, radiotelephony and few more. The requirements are significant in terms of reliability and robustness but not demanding in terms of throughput. In the second type, we find non-critical services that provide added-value to operators, like remote maintenance, condition-based maintenance systems, real-time video surveillance (Close Circuit TeleVision), and a large etcetera. The throughput needs to be high and both the delay and jitter delay need to be low. Finally, services for customers include WiFi access to the Internet, passenger information, *etc.*, which are non-critical at all and usually demand a very large capacity to the communications link. Coming from both new standards like 5G and the increased competitiveness from other transportation systems, many more services are coming in the future [12].

The Adaptable Communications System (ACS) prototypes for all railways under development in X2RAIL-3 project will be “technology independent”. This means that several bearers will coexist in parallel, for example LTE and Wi-Fi and satellite

communications. The ACS will be capable to select the suitable radio access network based on application requirements, user equipment coverage, traffic profile in the areas, *etc.* Therefore, the Emulradio4rail platform will have to consider many RATs: IEEE 802.11, 3GPP LTE, future 5G New Radio (5G NR) and satellite communications (SatComs) as it is illustrated in Fig. 1.

## 2.2 Railway scenarios

The word “railways” could be misleading because it covers a large array of scenarios like high-speed, mainline, regional, intercity, metro, tramway and, on a more general point of view, other related technologies which do not have rail-wheel contact like MagLev. Four main railway operating scenarios are considered in Shift2Rail: mainline, metro/urban, regional, freight.

In the aforementioned scenarios, rolling stock, speed, track geometry, surrounding environment differs, which implies that the radio propagation channel will differ as well. The way to address properly this diversity is to identify the radio channel models already published that fit better with each physical scenario to be considered.

In particular, high-speed trains and tunnels are the most challenging in terms of complexity and potential impact on the radio channel characteristics. Even when we consider tunnels, the propagation characteristics differ significantly depending on the shape, presence of curves, wall materials, *etc.* For example in [13] the authors present several challenges for wireless communications for the high-speed rail context. [14] presents a survey on channel measurements and models for high-speed train communication systems in the case of T2G. [15] proposes a Winner model in tunnels at 5.8 GHz for WiFi like systems. [16] highlights phenomenon like keyholes which make Multiple Input Multiple Output (MIMO) diversity useless in tunnel under certain conditions in tunnels. In Fig. 2 some examples railway environments are shown. High-speed lines are commonly assumed to be a rural scenario but, in fact, it is very frequent to go through cuttings, viaducts and tunnels whose propagation conditions differ on a significant way. In addition to the various geographical scenarios, it is important to mention that the radio channel model could be different for each RAT depending on frequency bands and bandwidth.

The wireless channel can be modeled inside an FPGA with a simple model known as the tapped delay line (TDL) [17]:

$$h(t, \tau) = \sum_{n=1}^N r_n(t, \tau_n(t)) e^{-j\Phi_n(t, \tau_n(t))} \delta(t, \tau_n(t)) \quad (1)$$

where  $h(t, \tau)$  represents the time-variant complex impulse response of  $r_n(t, \tau_n(t))$ . As can be observed in Fig. 3, each tap is the product of the complex baseband signal and a complex coefficient, which modifies the amplitude and phase signal together with the addition of a delay.

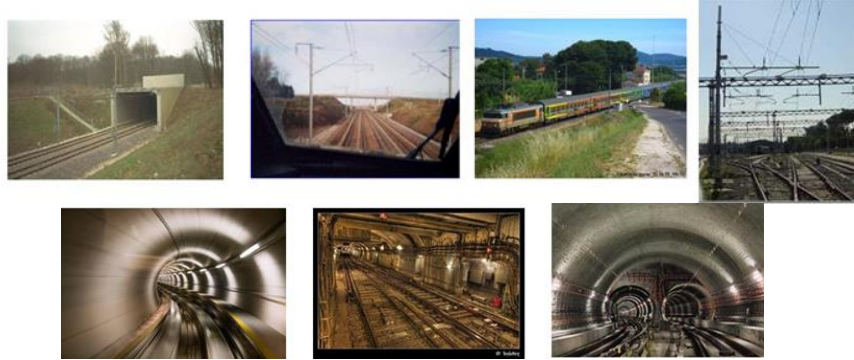

**Fig. 2:** Examples of different railway environments

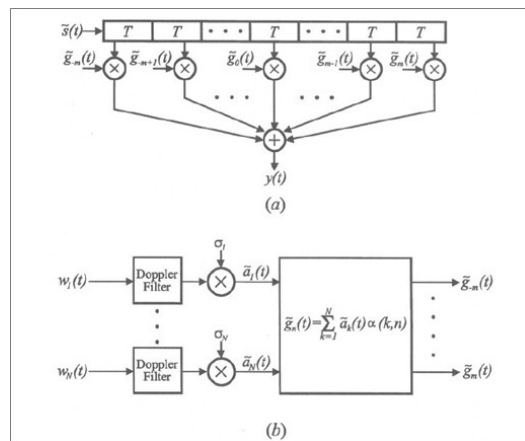

**Fig. 3:** Uniformly spaced TDL model for discrete multipath channel. (a) TDL structure; (b) generation of tap-gain processes: input processes are independent, zero-mean Gaussian processes. [18]

### 2.3 Perturbations

The radio channel emulation will have to take into account the main representative potential sources of degradation in the radio channel that could affect the overall performance. In general terms, there are two potential sources of degradation: non-intentional and intentional interferences. Examples of non-intentional interferences are interferences from public mobile operators using adjacent frequency bands, electric arcs formed in the imperfect pantograph-catenary contact [19], network overloads, *etc.* Among the intentional perturbations, we can consider also electromagnetic attacks with various types of jammers [20]. All these perturbations that could be found in the literary review need to be modelled and taken into account in the emulation platform in addition to the channel model.

Interference models have been widely used but essentially for receiver design or global network performance evaluation. They have been less applied in emulation environment; in particular the real time implementation, as well as the dependence structure (their dynamicity), are not so well studied. Besides, intentional interferences are also less known. Finally, they could necessitate some specific indicators, the traditional signal to noise ratio not being a sufficient statistics, because it ignores its impulsive characteristic. The impact on the RAT may vary (for example, GSM-R does not implement MIMO techniques; and the resilience against interference varies significantly if the waveform is narrowband or wideband).

### **3 Emulation platform**

The need for emulation of realistic radio environment conditions to test wireless communication systems is increasing for industry and transport applications where automation required deployment of various wireless communications [11], [21]. Emulradio4rail project will go a step further. The novelty proposed here is to consider coupling between RIVERBED Modeler and Open Air Interface (OAI) instead of considering classical network emulator. This solution will improve the Hardware/Software co-simulation platform with integration of a radio channel emulator as illustrated on Fig. 1. Using OAI network emulator reduces the cost of real equipment for establishing LTE network for example.

Riverbed Modeler is a discrete-event simulation tool used for the network modeling and performance evaluation. It supports various network types and technologies allowing to design and study communication networks, devices, protocols and applications. This simulator is a graphical-based editor that makes it easy to use for network components structure. Using RIVERBED Modeler provides abilities to simulate various network entities and analyse performances by models. The RIVERBED Modeler network simulator is deployed to provide capabilities to traffic monitoring and simulation of the trackside RATs. The co-simulation software modules capture the real LTE traffic from the LTE EPC, process the traffic in the simulation environment and forward the traffic to the application servers in the real environment. In such a way, it is possible to emulate the impact of different concurrent traffic types within the core network and assess the impact on the target traffic/ application under test.

OAI is an open-source hardware and software wireless technology platform created for research tasks and used for simulation, emulation and real-time execution of 3GPP cellular networks. The main advantages of OAI is its high level of realism. OAI is a Software Defined Radio (SDR) based solution and provides a complete software implementation of all elements of the 4G LTE system architecture. The methodology deployed in the OAI platform is to use the real protocol stack to perform more realistic and reliable emulations. Regarding the configurations for an in-lab radio network experiment, the OAI installs the software platform on the host computer and runs the full protocol stack in the emulation mode. The proposed eNodeB experimental testbed consists of two elements: RF hardware as the radio part and a computer as the baseband unit. The transceiver functionality is realized using a Software Defined Radio



(SDR) card connected to a host computer for processing. Besides, the EPC (Evolved Packet Core) features included in OAI can also be used in order to connect real equipment at IP level. The OAI is currently in evolution towards the future 5G.

The connection between the network emulator (OAI) and the network simulator (Riverbed modeler), a tool called System-In-The-Loop (SITL) provides an interface between a simulated network running in Riverbed Modeler and a real test platform. With SITL, a simulation environment can connect and interact with the external physical hardware in real-time.

The Emulradio4rail project will implement a software/hardware co-simulation model consisting of both physical emulator and software simulation environment. Combining real test environment and simulated network scenario, especially adding the channel emulator into an integrated platform, provides close-to-the-field test results in a lab-scale testbed. In this way, the testbed can offer quite a full-stack (from physical layer to IP level) test environment representative of the various railway environments thanks both to the various radio channel models and interference models implemented in the channel emulator.

## 4 Conclusions

The Emulradio4rail testing platform presented in this paper aims at proposing innovative solutions to drastically reduce the costs and burden of testing and validation procedures of the T2G adaptable communication systems with various RAT. This tool will increase accessibility to testing solutions in Europe and will reduce time-to-market for radio access technologies. The platform will permit reproducibility of tests with zero on site testing. We have seen the complexity of the task to be achieved due to the necessity to emulate a significant diversity of railway scenarios, services and potential perturbations. We have explained the detailed requirements in terms of these three aspects and the general approach for the development of the emulation platform, which will interface at IP layer with the T2G adaptable communications prototypes that will be provided by industry within the framework of X2RAIL-3 project.

## References

1. Available on : <https://shift2rail.org/>
2. X2RAIL-1 D3.1 - User & System Requirements (Telecommunications) – available for download on [http://projects.shift2rail.org/s2r\\_ip2\\_n.aspx?p=X2RAIL-1](http://projects.shift2rail.org/s2r_ip2_n.aspx?p=X2RAIL-1)
3. NGTC: D6.1\_Requirements\_Specifications\_for\_IPcomm\_system\_FINAL.pdf available for download at <http://www.ngtc.eu/results-publications/LNCS> Homepage, <http://www.springer.com/lncs>, last accessed 2016/11/21.
4. FRMCS requirements - Draft-3GPP-related-FRMCS-S1-171207-TR22.889V0.4.0.-rev
5. FRMCS: Future Rail Mobile Communications System, Available: <https://uic.org/frmcs>
6. Emulradio4rail: <http://www.emulradio4rail.eu> project – [https://projects.shift2rail.org/s2r\\_ip2\\_n.aspx?p=EMULRADIO4RAIL](https://projects.shift2rail.org/s2r_ip2_n.aspx?p=EMULRADIO4RAIL)
7. Riverbed. (April 2019). RIVERBED MODELER. The fastest discrete event-simulation engine for analyzing and designing communication networks. Available:

<https://www.riverbed.com/dk/products/steelcentral/steelcentral-riverbed-modeler.html>OpenAirInterface - <https://www.openairinterface.org/>

8. OpenAirInterface. 5G software alliance for democratising wireless innovation. Available: <https://www.openairinterface.org/>
9. B. Allen, B. Eschbach, M. Mikulandra, Defining an Adaptable Communications System for all railways, in proceedings 7th Transport Research Arena TRA 2018 (TRA 2018) (TRA2018), Vienna, 16-19 April 2018, DOI: 10.5281/zenodo.1456472
10. M. Bouaziz, Y. Yan, M. Kassab, J. Soler, M. Berbineau, "Evaluating TCMS Train-to-Ground communication performances based on the LTE technology and discrete event simulations", 13th International workshop on communication technologies for vehicles (Nets4cars-Nets4trains-Nets4Aircraft-Nets4spacecrafts), May 2018
11. V. Diez *et al.*, "Validation of an LTE backbone for inter-car communications in metro environments," *12th European Conference on Antennas and Propagation (EuCAP 2018)*, London, 2018, pp. 1-5. doi: 10.1049/cp.2018.0960
12. J. Moreno, J. M. Riera, L. d. Haro and C. Rodriguez, "A survey on future railway radio communications services: challenges and opportunities," in *IEEE Communications Magazine*, vol. 53, no. 10, pp. 62-68, October 2015. doi: 10.1109/MCOM.2015.7295465
13. J. Wu and P. Fan, "A Survey on High Mobility Wireless Communications: Challenges, Opportunities and Solutions," in *IEEE Access*, vol. 4, pp. 450-476, 2016. doi: 10.1109/ACCESS.2016.2518085
14. C. Wang, A. Ghazal, B. Ai, Y. Liu and P. Fan, "Channel Measurements and Models for High-Speed Train Communication Systems: A Survey," in *IEEE Communications Surveys & Tutorials*, vol. 18, no. 2, pp. 974-987, Second quarter 2016. doi: 10.1109/COMST.2015.2508442
15. S. Hairoud, P. Combeau, Y. Pousset, Y. Cocheril and M. Berbineau, "WINNER model for subway tunnel at 5.8 GHz," 2012 12th International Conference on ITS Telecommunications, Taipei, 2012, pp. 743-747. doi: 10.1109/ITST.2012.6425280
16. J. Moreno, L. de Haro, C. Rodríguez, L. Cuéllar and J. M. Riera, "Keyhole Estimation of an MIMO-OFDM Train-to-Wayside Communication System on Subway Tunnels," in *IEEE Antennas and Wireless Propagation Letters*, vol. 14, pp. 88-91, 2015. doi: 10.1109/LAWP.2014.2356076
17. J. G. Proakis and M. Salehi, *Digital Communications*: McGraw-Hill, 2008.
18. M. C. Jeruchim, P. Balaban, and K. S. Shanmugan, *Simulation of communication systems: modeling, methodology and techniques*: Springer Science & Business Media, 2006.
19. K. Hassan, R. Gautier, I. Dayoub, M. Berbineau and E. Radoi, "Multiple-Antenna-Based Blind Spectrum Sensing in the Presence of Impulsive Noise," in *IEEE Transactions on Vehicular Technology*, vol. 63, no. 5, pp. 2248-2257, Jun 2014. doi: 10.1109/TVT.2013.2290839
20. V. Deniau, C. Gransart, G. L. Romero, E. P. Simon and J. Farah, "IEEE 802.11n Communications in the Presence of Frequency-Sweeping Interference Signals," in *IEEE Transactions on Electromagnetic Compatibility*, vol. 59, no. 5, pp. 1625-1633, Oct. 2017. doi: 10.1109/TEM.2017.2684428
21. A. Schwind, P. Berlt, M. Lorenz, C. Schneider and M. A. Hein, "Over-the-air MIMO channel emulation for automotive LTE radio systems using software defined radio," 12th European Conference on Antennas and Propagation (EuCAP 2018), London, 2018, pp. 1-5. doi: 10.1049/cp.2018.0399