



HAL
open science

Eigencalculation of Coupling Modes in Large-Scale Interconnected Power Systems with High Power Electronics Penetration

Mohamed Kouki, Bogdan Marinescu, Florent Xavier

► **To cite this version:**

Mohamed Kouki, Bogdan Marinescu, Florent Xavier. Eigencalculation of Coupling Modes in Large-Scale Interconnected Power Systems with High Power Electronics Penetration. 2018 Power Systems Computation Conference (PSCC), Jun 2018, Dublin, Ireland. pp.1-7, 10.23919/PSCC.2018.8443031 . hal-02510511

HAL Id: hal-02510511

<https://hal.science/hal-02510511>

Submitted on 18 Mar 2020

HAL is a multi-disciplinary open access archive for the deposit and dissemination of scientific research documents, whether they are published or not. The documents may come from teaching and research institutions in France or abroad, or from public or private research centers.

L'archive ouverte pluridisciplinaire **HAL**, est destinée au dépôt et à la diffusion de documents scientifiques de niveau recherche, publiés ou non, émanant des établissements d'enseignement et de recherche français ou étrangers, des laboratoires publics ou privés.

Eigen calculation of Coupling Modes in Large-scale Interconnected Power Systems with High Power Electronics Penetration

M. Kouki*, B. Marinescu* and F. Xavier†,

* Ecole Centrale Nantes-LS2N-CNRS, France

{Mohamed.Kouki,Bogdan.Marinescu}@ec-nantes.fr

† RTE-R&D

9, rue de la Porte de Buc, 78000 Versailles, France

florent.xavier@rte-france.com

Abstract—The penetration of power electronics in large-scale interconnected power systems has significantly increased in the recent years. As a consequence, the electromechanical inter-area modes are no longer the majority of modes which involve distant dynamic (modeled by differential equations) devices, i.e., of coupling modes. In this paper we develop a new methodology which allows one to determine all the coupling modes (modes related to classic synchronous generators with large inertia, modes related to power electronics (Power Park Modules) of a given power system. To this end, we excite the system with well-chosen temporal signals and analyse the correlation between the obtained outputs. This leads to the identification of classes of coupled dynamic devices of the grid. Next, a selective modal analysis method is applied to each class to determine good approximations of coupling modes which involve the devices of the class. Finally, iterative search of eigenvalues initialized at the approached values of the coupling modes found at the previous stage lead to exact values of the eigenvalues of the overall power system. The proposed methodology is applied on the 23 machines model of the Spain-France interconnection.

Index Terms—Coupling/Inter-Area Modes, Modal Analysis, Eigen calculation, Large-Scale Power Systems, Power Electronics.

I. INTRODUCTION

The European electricity network is evolving due, in particular, to new interconnections, Power Park Modules (PPMs), i.e, sources connected to the grid (Renewable Energy (RE), Distributed Generation (DG), storage, etc) by power electronics and FACTS (STATCOM, HVDC,...). They enlarge thus the class of devices with models which consist of differential equations called *dynamic devices* in the sequel. In the past, it was custom to consider this class exclusively composed by classic synchronous generators. A first consequence is the increase of the size of the resulting mathematical model which is a challenge, especially for modal analysis, i.e., computation of eigenvalues and eigenvectors in order to determine the main oscillatory dynamics of the systems and the parts (variables) involved in.

Moreover, most of the aforementioned grid components consist of power electronic devices (VSC converters) or are connected to the grid via such elements. This leads to new signatures of the oscillatory modes which involve distant devices of the grid called *coupling modes* in the sequel. Indeed, in the past, these modes, called *inter-area modes*, were quasi-exclusively due to large thermic synchronous generators of which turbine shafts oscillate one against other (see, e.g., [14]).

Classes of generators which swing together for a given *disturbance* were constructed based on *coherency* (see [4], [6], [12], [15] or related references). To define classes with respect to given *modes*, *synchrony* was introduced ([7], [13] and related references). However, power grids which contain power electronics may have coupling modes of different nature. For example, in [1] and [2] coupling modes between classic synchronous generators but not of inter-area nature were put into evidence. They are related to the electric parts (axes D or Q) of distant generators. In [10] oscillatory modes between converters of distant HVDCs were put into evidence and analyzed. Also, power converters (from HVDC or Power Parks Modules) may have important participation in inter-area modes and thus interact with synchronous generators [1], [5], [18].

Modal analysis methods should change in accordance to the nature of the coupling modes mentioned above. More precisely, the dominant devices in a coupling mode are not only among the large synchronous generators with large inertia. New efficient computation methods must be proposed to cover this general case which becomes actual in case of large power electronics penetration. Another problem is to find in an exhaustive manner all the coupling modes of a given grid, i.e., to scan unknown or new grid model.

In this paper we develop a new methodology to overcome the difficulties mentioned above. It provides a way to

systematically excite and put into evidence all the coupling modes of a given power system. The proposed methodology works independently of the system's order. Also, the method does not require any a priori knowledge neither about the nature of modes nor about the participating devices. To this end, we excite each dynamic device of the power system with well-chosen temporal signals. We next analyze the correlation between the obtained outputs of all dynamic devices to aggregated them into *classes* of coupled dynamic devices of the grid.

This is the main difference (and advantage) compared to existing approaches which compute modes given a good and precise starting guess or perform a global scan only for the inter-area modes.

Next, the modes of each class are computed based on the Selective Modal Analysis (SMA) approach [11] to finally provide all the coupling modes of the overall system.

The rest of this paper is organized as follows. Section II presents the mathematical model used for the power system and brief description of SMA algorithm. Section III gives the details of proposed approach. Section IV gives computation results on a 23 machines model of the Spain-French interconnection. Conclusions and perspectives of future work are given in Section V.

II. BASIC TOOLS

In this section we present some mathematical tools and brief description of SMA algorithm, which will be used subsequently.

A. General power system model

A power system is generally composed of some dynamic components (generators, dynamic loads, regulators, converters,...). The mathematical model which results from an analytical modeling is a *Differential Algebraic Equations* (DAE) form

$$\begin{cases} \dot{x} = f(x, y) \\ 0 = g(x, y), \end{cases} \quad (1)$$

where x represents the differential variables (machines angles and speeds, regulators state-variables, ...) and y the algebraic ones (grid voltages).

The linearization of (1) around an equilibrium point (x_0, y_0) gives

$$\begin{cases} \dot{x} = Mx + Ny \\ 0 = Px + Qy. \end{cases} \quad (2)$$

Equation (2) can be rewritten as:

$$\begin{bmatrix} \dot{x} \\ 0 \end{bmatrix} = E \begin{bmatrix} x \\ y \end{bmatrix} \text{ with } E = \begin{bmatrix} M & N \\ P & Q \end{bmatrix} \quad (3)$$

where $E \in \mathbb{R}^{e^*e}$ and e is the total number of variables. If Q is invertible, from (3), we can deduce a *state-space form*

$$\dot{x} = Ax, \quad (4)$$

where $A = M - NQ^{-1}P \in \mathbb{R}^{n^*n}$. Notice that n is the length of x , i.e, equal to the number of differential variables. Generally the A matrix is used by some power system softwares in the stability study of overall power system.

B. Eigenanalysis

1) *Eigenvalues*: For exponentially stable (i.e, $\sigma_i < 0$) complex conjugate eigenvalues of matrix A in (4)

$$\lambda_i = \sigma_i \pm jw_i, \quad (5)$$

the real part and the imaginary part are used to compute the *damping ratio* ξ_i (in %) and the *oscillation frequency* f_i (in Hz):

$$\xi_i = \frac{-\sigma_i}{\sqrt{\sigma_i^2 + w_i^2}}, \quad f_i = \frac{w_i}{2\pi}. \quad (6)$$

The damping ratio gives the rate at which the oscillation amplitude decreases and thus represents the risk of instability.

2) *Eigenvectors*: The computation of the eigenvectors can give other information about the nature of the oscillations. They determine the way in which each mode contributes to a particular state and the *shape of inter-area oscillations* (see, e.g., [14]). The right eigenvectors are piled as columns of matrix V_r and the left eigenvectors as lines of W_l which satisfy

$$\begin{cases} AV_{r_i} = \lambda_i V_{r_i} \\ W_{l_i} A = \lambda_i W_{l_i} \\ W_l AV_r = \Lambda \end{cases} \text{ for } i = 1, \dots, n. \quad (7)$$

where $\Lambda = \text{diag}\{\lambda_1, \dots, \lambda_n\}$, with λ_i eigenvalues of A .

C. Participation factors

The participation factors better quantify the link between the states and the modes. The participation factor of the j^{th} variable in the i^{th} mode is defined by

$$p_{ji} = w_{ji}v_{ji}, \quad (8)$$

with, w_{ji} and, respectively, v_{ji} , the j^{th} component of left, respectively, right eigenvector of the i^{th} mode.

If the eigenvectors are orthonormal (i.e., if $W_l = V_r^{-1}$), then

$$\sum_{i=1}^n p_{ji} = \sum_{j=1}^n p_{ji} = 1 \quad (9)$$

which allows one to compare the contribution of different states in a given mode (or, equivalently, of different modes in a given state).

D. Selective Modal Analysis [11]

SMA is an efficient way to characterize and analyze individually selected parts of large-scale linear systems ($\dot{x} = Ax$) provided they have small interactions. It requires thus the vector of state variables x to be divided into two parts, one of relevant variables r , and the other one of less relevant variables z in the sense that the dynamics of z have little influence on

the dynamics of r (the length of r is also much smaller than the length of z) as follows:

$$\begin{bmatrix} \dot{r} \\ \dot{z} \end{bmatrix} = \begin{bmatrix} A_{rr} & A_{rz} \\ A_{zr} & A_{zz} \end{bmatrix} \begin{bmatrix} r \\ z \end{bmatrix} \quad (10)$$

with $r \in \mathbb{R}^q$ and $z \in \mathbb{R}^{n-q}$. Diagram in Fig. 1 corresponds to this state partition and leads to the transfer matrix of the less relevant dynamics

$$H(s) = A_{rz}(sI - A_{zz})^{-1}A_{zr}. \quad (11)$$

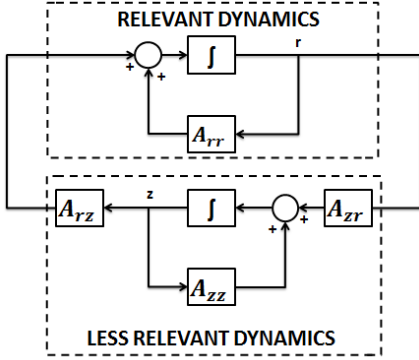

Figure 1. Block diagram representation of a linear dynamic system with separation of relevant and less relevant dynamics

The eigencomputation is run only on the relevant variables and the less relevant ones are only used to take into account the (small) influence of the missing part of the system on the eigenvalues of interest. The idea consists of obtaining a transfer matrix $\mathbf{M}(s)$ of the less relevant dynamics valid for several modes of interest. The block diagram of Figure 1 could be represented as shown in Figure 2. The computation of $\mathbf{M}(s)$ is done in Algorithm 1 which summarizes the SMA procedure.

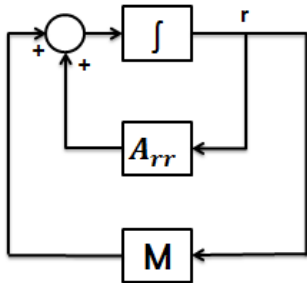

Figure 2. Block diagram representation of a linear dynamic system with matrix transfer function representation of the less relevant dynamics

Convergence of Alorithm 1 is ensured if the split of the state variables (10) is effective, i.e., dynamics of z have little influence on dynamics of r [11].

Remark 1. The *STOP CONDITION* is, in general, the validation of ${}^{k+1}\lambda_i$ as eigenvalue of A . This leads to a condition of the form

$$\text{cond}({}^{k+1}\lambda_i * I - A) \geq \varepsilon \text{ OR } k \geq k_{max}, \quad (12)$$

Algorithm 1: SMA (Inputs: $A, A_{rr}, A_{rz}, A_{zr}, A_{zz}$; Outputs: Λ_r =eigenvalues related to r , V_r =eigenvectors related to r)

```

(1) Determine the initial set of modes of interest  $\{{}^0\Lambda_r$ 
and  ${}^0V_r\}$  by using the eigenanalysis of  $A_{rr}$ , that is:
 $A_{rr}{}^0V_r = {}^0V_r{}^0\Lambda_r$ , with  ${}^0\Lambda_r = \{{}^0\lambda_1, \dots, {}^0\lambda_r\}$ 
 $k = 0$ 
(2) while (STOP CONDITION==FALSE) do
  (2.1) for  $i = 1, \dots, r$  do
    Compute the transfer function  $H({}^k\lambda_i)$ 
     $H({}^k\lambda_i) = A_{rz}({}^k\lambda_i * I - A_{zz})^{-1}A_{zr}$ , with  $I$  the
    identity matrix.
  end
  (2.2) Compute the transfer matrix  ${}^{k+1}\mathbf{M}$  of the less
  relevant dynamics corresponding to the eigenvalue of
  interest according to:
   ${}^{k+1}\mathbf{M}{}^kV_r = [H({}^k\lambda_1)v_1 \dots H({}^k\lambda_r)v_r]$ 
  (2.3) Perform the eigenanalysis of modified matrix
   ${}^{k+1}A_{rr}$  and select the modes of interest  $\{{}^{k+1}\Lambda_r$  and
  associated right eigenvectors  ${}^{k+1}V_r\}$ 
   ${}^{k+1}A_{rr} = {}^kA_{rr} + {}^{k+1}\mathbf{M}$ 
  (2.4) Compute STOP CONDITION
  if (STOP CONDITION==TRUE) then
    | Stop and  ${}^{k+1}\Lambda_r = \{{}^{k+1}\lambda_1, \dots, {}^{k+1}\lambda_r\}$ 
  else
    |  $k=k+1$ 
  end
end

```

where k_{max} is the maximum number of allowed iterations. Indeed, ${}^{k+1}\lambda_i$ is an eigenvalue of A if, and only if matrix ${}^{k+1}\lambda_i * I - A$ is singular, i.e., its condition number is ∞ in theory. In practice, we check if its condition number is greater than a threshold ε , which leads to (12).

A good precision (like, e.g. $\varepsilon = 10^6$) will lead to accurate estimation of eigenvalues. However, practical experimentation conducted us to the conclusion that, for the case of our problem, it is preferable to run with a rough precision ($\varepsilon \sim 10^3$) in order to capture at this stage a large number of at least candidates for exact eigenvalues. They would be refined in our additional step of exact selective modal analysis to exact eigenvalues of A . This allows one not to miss modes at this step. This will be shown on the example treated in Section IV.

Notice that if there are important interactions between r and z , Algorithm 1 could found no eigenvalue.

III. PROPOSED METHODOLOGY

The proposed methodology to systematically find all the coupling modes of a given power system is structured into three parts.

First, classes of the coupled dynamic devices are constructed by exciting one by one each dynamic device with short-circuits. Indeed, such a large disturbance involve a maximum number of dynamics. Correlation between the obtained voltage

responses is next analysed to identify all the classes of coupled dynamic devices of the grid.

This choice of inputs/outputs will be refined in future extensions of this work (see Section V). The coupled dynamic devices selection is determined on the basis of the gap between the steady-state level of the signals and the responses to the excitations mentioned above.

Next, SMA is done for each class. At each stage, coupling modes of the overall system are found among the modes of the class. The coupling modes of the system are identified in an exhaustive manner if all the classes are treated. Moreover, because of the redundancy of the sets of modes found for each class, the full set of coupling modes can be found even without treating all the classes as shown in the study case presented in the next section.

Finally, the coupling modes found above are used as starting points for iterations which converge to the exact values of the modes of the overall system (see Remark 1). For this, any classic selective modal analysis method like, e.g. Arnoldi or Generalized Selective Modal Analysis can be used [3].

A. Classes Identification

Let us assume that the studied grid model contains m dynamic devices and consider the excitations mentioned in the section above.

Let

$$y = \max_t \left\{ \frac{|V_j(t) - V_j(t_0)|}{V_j(t_0)} \right\}, \quad (13)$$

be the maximum overshoot of the measured output of j^{th} dynamic device with respect to its steady-state value.

Let

$$u = \max_t \left\{ \frac{|V_i(t) - V_i(t_0)|}{V_i(t_0)} \right\}, \quad (14)$$

be the amplitude of the disturbance applied at the i^{th} device. As metallic short-circuits are chosen as disturbances (and the voltage drop is 100%), $u = 1$.

The j^{th} dynamic device is considered coupled with the i^{th} one if $\frac{y}{u} > \delta$, where δ is a threshold to be defined. The threshold value presents a relevant criterion for the construction of classes. According to this criterion, the devices coupled for the i^{th} mode will be selected, i.e., the number of dynamic devices selected in each class varies according to δ .

The threshold δ was chosen at this stage equal to 1%. This is a very small value which allows one to ensure high redundancy in the construction of each class. As a consequence, a maximum number of modes will be found for the analysis of each class and, in the end, the analysis is surely exhaustive in the sense that all the coupling modes of the overall system will be found. The price to pay is, of course the large number of generators in each class. The trade-off between the amplitude of the threshold δ and the resulting number of dynamic devices of each class will be investigated in future work.

This protocol is carried out with all dynamic devices. From these tests, a quasi-symmetric matrix made up with all coupled devices (see Table I for the case treated in this paper). Each

line corresponds to the device where the disturbance is applied (reference device) and the columns give all other devices which are coupled with this reference device.

The main steps of the proposed approach are summarized in Algorithm 2:

Algorithm 2: Iterative Coupled Mode approach (**Inputs:** *Grid – model*; **Outputs:** Coupling modes)

- (1) Linearize the grid model and generate the state matrix A
 - (2) Generate the classes of coupled devices
 - (3) **for** $i=1:m$ **do**
 - (3.1) Apply the test-scenario in t instant at the i^{th} reference dynamic device,
 - (3.2) **for** $j=1:m$ **do**
 - According to the threshold δ , select the different coupled dynamic devices
 - end**
 - (4) **for** $k=1:\text{number of classes}$ **do**
 - (4.1) Generate the sub-matrices ($A_{rr}, A_{rz}, A_{zr}, A_{zz}$) for each class
 - (4.2) Apply the SMA algorithm and compute the modes related to the relevant dynamics (state variables r in (10))
 - (4.3) Select only the complex eigenvalues
 - end**
 - (5) Starting from each mode found at each class, do a full eigencalculation in order to obtain the exact values of the modes of the overall system.
 - (6) Perform full modal analysis (mode shape, participation factors, ...) to state which of the founded modes are really coupling modes.
-

IV. NUMERICAL RESULTS

This section reports the numerical results of the application of the proposed methodology to a simplified representation of Spain-France interconnection (Fig. 3). It consists of 23 generators, 83 buses, 247 branches, 65 loads. See [2] for more details about this model.

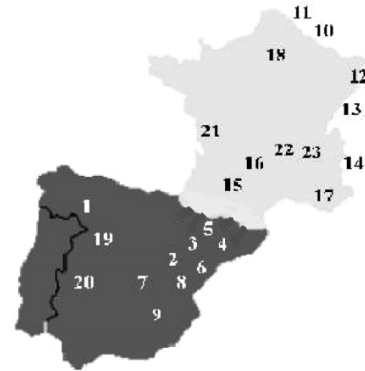

Figure 3. France-Spain interconnected systems

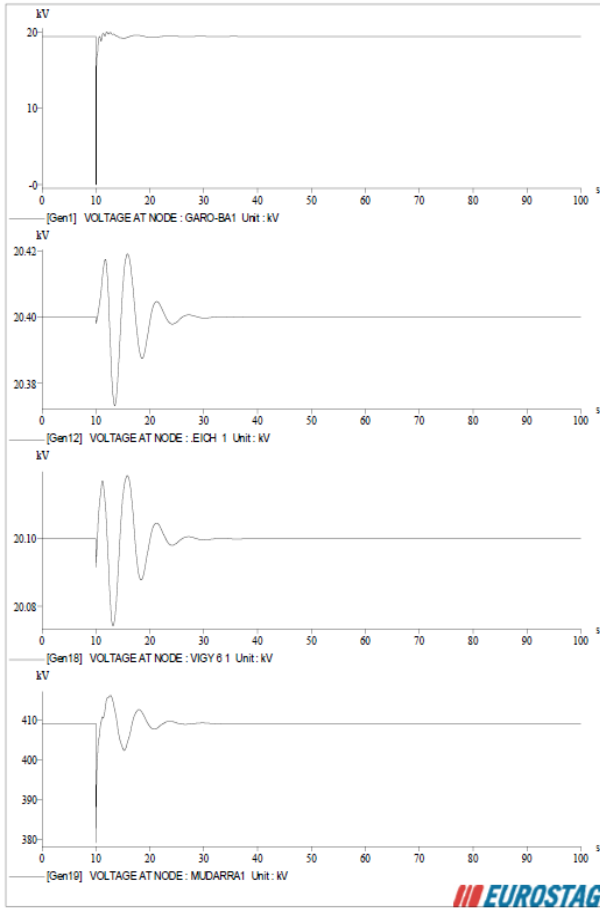

Figure 4. Terminal voltage responses to the G1 short-circuit

The disturbance used at Step 2 of Algorithm 2 is a *short-circuit* applied at $t_1 = 10s$ and eliminated at $t_2 = 10.1s$. Simulations are carried out with Eurostag software [9]. An illustrative example of coupled generators selection is given in Fig. 4, where the reference generator is the generator number 1 and the responses for some generators (G1, G12, G18 and G19) are given in the same figure.

The steady-state before the short-circuit of terminal voltages of G1, G12, G18 and G9 are equal to $19.43kV$, $20.4kV$, $20.1kV$ and $409kV$, respectively. After the application of the disturbance at $t = 10s$ at G1, we notice from Fig. 4 that the maximum overshoot of the measured voltage of the G1 is $20kV$ which corresponds to 100% according to (14). For the other generators, as follows:

- for G12 : $0.02kV$ which corresponds to 0.09%
- for G18 : $0.02kV$ which corresponds to 0.09%
- for G19 : $39kV$ which corresponds to 10%

Using the criterion and the threshold proposed in Section III, generator G19 is coupled with generator G1 but it is not coupled with generators G12 and G18. Thus, generator G19 is considered one of the generators of first class. This kind of test is carried out with the remaining generators.

Table I provides the resulting classes. The number of classes

provided in Table I is 23 (equal to the number of generators, i.e., of the dynamic devices of the system).

Column 2 of Table II provides the list of modes obtained with SMA (step 4 of Algorithm 2) for each class. For a given class k , are given only the new modes found for this class, i.e., which have not been found for classes $1, \dots, k - 1$.

Notice that all the modes are found using only 6 classes among the total amount of 23.

In the third column of the same table is given the exact value of the mode computed directly on the overall system (with SMAS3 tool [8], [16]). Notice that this is possible for this benchmark because its size is not too large.

The proposed methodology has very precisely generated all the coupling modes, except three modes (mode 1, mode 2 and mode 62) for which the differences are very small. This means that the constructed classes are efficient in the sense that there are no significant interactions between the dynamic devices of each of these classes and the rest of the system. The small differences pointed out before are due to the (low) precision chosen for the STOP CONDITION of SMA research (See Remark 1). They are easily eliminated at step 6 of Algorithm 2. Table III gives the results of this computation (with Modified Arnoldi method initialized at the figures given in column 2 of the same table) for the three aforementioned modes. It can be seen that the values of the full model modes of column 3 of Table II are retrieved with very good precision.

Notice that if ε of the STOP CONDITION is increased from 10^3 to 10^6 , modes 1, 2 and 62 would no longer be found by Algorithm 1. It was thus concluded that it is preferable to work with a lower precision ε and to add step 5 to Algorithm 2.

For step 6 of Algorithm 2, full modal analysis must be performed for each mode found at step 5. Table IV provides the results for mode 5 which is thus proven to be an inter-area mode. As a matter of fact, we notice in column 3 phase opposition of right eigenvectors associated to the speed deviations between the most participating machines as well as several distant generators involved in the mode.

Tables V gives the results for mode 27. It is a coupling mode since it involves 2 distant generators with significant participation. However, no phase opposition is noticed for the right eigenvectors. Also, the most participating parts are not the rotors but the D axes. This is not an inter-area mode but an *electric coupling mode* as defined in [1] and [2].

V. CONCLUSIONS

In this paper, we proposed a new methodology that is able to find all coupling modes of a given power system. This methodology does not require any a priori knowledge neither about the nature of modes nor about the participating dynamic devices. This methodology enables to directly consider any kind of dynamic devices of the power system like, e.g. Power Park Modules and not only classic synchronous generators.

TABLE I
DIFFERENT GENERATED CLASSES

	G1	G2	G3	G4	G5	G6	G7	G8	G9	G10	G11	G12	G13	G14	G15	G16	G17	G18	G19	G20	G21	G22	G23
G1		✓	✓	✓		✓	✓	✓	✓						✓				✓	✓	✓		✓
G2	✓		✓	✓	✓	✓	✓	✓	✓						✓	✓	✓		✓	✓	✓	✓	✓
G3	✓	✓		✓	✓	✓	✓	✓	✓						✓	✓	✓		✓	✓	✓	✓	✓
G4	✓	✓	✓		✓	✓	✓	✓	✓						✓	✓			✓			✓	
G5		✓	✓	✓		✓	✓	✓	✓														
G6	✓	✓	✓	✓	✓		✓	✓	✓						✓	✓			✓		✓		
G7	✓	✓	✓	✓	✓	✓		✓	✓						✓	✓	✓		✓	✓	✓		✓
G8	✓	✓	✓	✓	✓	✓	✓	✓	✓						✓				✓				
G9	✓	✓	✓	✓	✓	✓	✓	✓	✓						✓				✓	✓			
G10	✓										✓				✓	✓		✓	✓		✓	✓	✓
G11	✓									✓					✓	✓	✓	✓	✓		✓	✓	✓
G12	✓						✓		✓	✓	✓		✓	✓	✓	✓	✓	✓	✓		✓	✓	✓
G13	✓											✓		✓	✓	✓	✓	✓	✓		✓	✓	✓
G14	✓														✓	✓	✓	✓	✓		✓	✓	✓
G15	✓									✓	✓					✓	✓	✓	✓		✓	✓	✓
G16		✓	✓	✓	✓	✓	✓	✓							✓	✓	✓				✓	✓	✓
G17		✓	✓	✓		✓								✓	✓	✓					✓	✓	✓
G18	✓									✓	✓	✓	✓		✓	✓	✓		✓		✓	✓	✓
G19	✓	✓	✓	✓		✓	✓	✓	✓						✓					✓	✓		
G20	✓	✓	✓	✓		✓	✓								✓	✓			✓		✓	✓	✓
G21	✓	✓	✓	✓		✓	✓								✓	✓	✓	✓	✓		✓	✓	✓
G22				✓		✓								✓	✓	✓	✓				✓	✓	✓
G23				✓		✓								✓	✓	✓	✓				✓	✓	

As it provides a scan of the system for all coupling modes, it also facilitates the computation of all remaining modes of the system (which do not involve distant devices). Indeed, such a mode involve dynamics of only one device which can belong to a class of coupled devices identified in this work or not. In the first case, the mode is computed with the other modes of the class. In the second case, the device is not coupled with another one and an SMA computation for which the relevant dynamics are the ones of this device will provide all (local) modes of the considered device.

In this work the different classes are determined manually by applying a disturbance on each reference generator. It will be extended in future work to a more systematic and automatic procedure. This will open the way to application to large-scale grids.

REFERENCES

[1] L. Arioua and B. Marinescu, *Multivariable control with grid objectives of an HVDC link embedded in a large-scale AC grid*, International Journal of Electrical Power & Energy Systems, Vol. 72, pp. 99-108, 2015.

[2] L. Arioua and B. Marinescu, *Robust grid-oriented control of high voltage DC links embedded in an AC transmission system*, International Journal of Robust and Nonlinear Control, Vol. 26(9), pp. 1944-1961, 2016.

[3] J. Barquin, L. Rouco and H. R. Vargas, *Generalized selective modal analysis*, IEEE Power Engineering Society Winter Meeting, Vol. 2, pp. 1194-1199, 2002.

[4] J. H. Chow, et al., *Inertial and slow coherency aggregation algorithms for power system dynamic model reduction*, IEEE Transactions on Power Systems, Vol. 10(2), pp. 680-685, 1995.

[5] S. Eftekharijrad, V. Vittal, G. T. Heydt, B. Keel and J. Loehr, *Small signal stability assessment of power systems with increased penetration of photovoltaic generation: A case study*, IEEE Transactions on Sustainable Energy, Vol. 4, no. 4, pp. 960-967, 2013.

[6] A. M. Khalil and T. Reza, *A dynamic coherency identification method based on frequency deviation signals*, IEEE Transactions on Power Systems, Vol. 31(3), pp. 1779-1787, 2016.

[7] B. Marinescu, M. Badis and L. Rouco, *Large-scale power system dynamic equivalents based on standard and border synchrony*, IEEE Transactions on Power Systems, Vol. 25(4), pp. 1873-1882, 2010.

[8] B. Marinescu and L. Rouco, *A unified framework for nonlinear dynamic simulation and modal analysis for control of large-scale power systems*, In Proc. Power Systems Computations Conference, Vol. 152, pp.1-7, Liege-Belgium, August 2005.

[9] B. Meyer and M. Stubbe, *Eurostag, a single tool for power system simulation*, in Proc. T&D Int., Mar. 1992.

[10] I. Munteanu, B. Marinescu and F. Xavier (2017). *Analysis of the interactions between close HVDC links inserted in an AC grid*, In Proc. IEEE Power & Energy Society General Meeting, July 16-20, Chicago, Illinois, USA.

[11] I. J. Perez-Arriaga, G. C. Verghese and F. C. Schweppe, *Selective Modal Analysis with Applications to Electric Power Systems, PART I: Heuristic Introduction*, IEEE Transactions on Power Apparatus and Systems, Vol. PAS-101(9), pp. 3117-3125, 1982.

[12] R. Podmore, *Identification of Coherent Generators for Dynamic Equivalents*, IEEE Transactions on Power Apparatus and Systems, Vol. PAS-97, pp. 1344-1354, 1978.

[13] G. N. Ramaswamy, G. C. Verghese, L. Rouco, C. Vialas and C. L. Demarco, *Synchrony, aggregation and multi-area eigenanalysis*, IEEE Transactions on Power Systems, Vol. 10, no. 4, pp. 1986-1993, Nov. 1995.

[14] G. Rogers, *Power system oscillations*, Springer Science & Business Media, Ed. 1, pp. XI-328, 2000.

[15] G. Rogers, *Power system coherency and model reduction*, New York: Springer, Ed. 1, Vol. 94, pp. I-300, 2013.

[16] L. Rouco, I.J. Pérez-Arriaga, R. Criado Calero and J. Soto, *A computer package for analysis of small signal stability in large electric power systems*, Proceedings of the 11th Power Systems Computation Conference, pp. 1141-1148, Avignon (France), August 1993.

[17] R. Singh, M. Elizondo, S. Lu, *A review of dynamic generator reduction methods for transient stability studies*, In Proc. Power and Energy Society General Meeting, Vol. 152, pp.1-8, Detroit, MI, USA, 24-29 July 2011, IEEE.

[18] F. Xavier, and B. Marinescu (2013), *Analysis of a dynamic equivalent for representation of wind generation for modal analysis of large-scale power systems*, PowerTech (POWERTECH), 16-20 June, Grenoble, 2013.

TABLE II
COMPARISON BETWEEN PROPOSED METHODOLOGY AND FULL MODEL

Number	Mode with New Methodology	Mode of full model	Class
1	-50.0394±j7.1054e-15	-50.042±j0.0001	1
2	-37.5814±j0.7695	-37.5016±j0.6842	1
3	-22.0665±j1.1181e-15	-22.0904±j0.0047	1
4	-1.0299±j10.0635	-1.0194±j10.0292	1
5	-0.9325±j8.9418	-0.9325±j8.7160	1
6	-13.5989±j0.0486	-13.6074±j0.0363	1
7	-12.7025±j0.9119	-12.7041 ±j0.9209	1
8	-2.0608±j8.0657	-2.0616±j8.0643	1
9	-0.5873±j7.2499	-0.6016±j7.2280	1
10	-0.5130±j7.1065	-0.5057±j7.1105	1
11	-0.4139±j6.4603	-0.4146±j6.4595	1
12	-1.9356±j6.4785	-1.9283±j6.5036	1
13	-10.5174±j0.7298	-10.5154±j0.7287	1
14	-0.3084±j5.5499	-0.2876±j5.4177	1
15	-6.0659±j0.4383	-6.0455±j0.4717	1
16	-2.1401±j2.0056	-2.1413±j2.0343	1
17	-0.5306±j1.3505	-0.4658±j1.3355	1
18	-4.0397±j0.6234	-4.0394±j0.6262	1
19	-4.2948±j0.1979	-4.2918±j0.1799	1
20	-3.4297±j0.7277	-3.4300±j0.7148	1
21	-0.2059±j1.0676	-0.3008±j1.0570	1
22	-1.3500±j0.8326	-1.4135±j0.7998	1
23	-0.6658±j0.7683	-0.6692±j0.7725	1
24	-0.6116±j0.6817	-0.6192±j0.6878	1
25	-3.2307±j0.0089	-3.2230±j0.0151	1
26	-2.0689±j0.0823	-2.1160±j0.0899	1
27	-0.2894±j0.5739	-0.2962±j0.5685	1
28	-0.3226±j0.5564	-0.3218±j0.5569	1
29	-0.5286±j0.4708	-0.5280±j0.4719	1
30	-0.4187±j0.4105	-0.4185±j0.4108	1
31	-0.2515±j0.1086	-0.2501±j0.1069	1
32	-0.1558±j0.0782	-0.1577±j0.0758	1
33	-0.1838±j0.0559	-0.1912±j0.0657	1
34	-10.0640±j10.2195	-10.0640±j10.2195	2
35	-0.8240±j9.2532	-0.8240±j9.2531	2
36	-0.8347±j9.0916	-0.8348±j9.0916	2
37	-2.5909±j8.7078	-2.5909±j8.7076	2
38	-1.1302±j7.5639	-1.1302±j7.5638	2
39	-0.3808±j6.0167	-0.3807±j6.0167	2
40	-0.5685±j5.0006	-0.5737±j5.0038	2
41	-0.7051±j4.3033	-0.6661±j4.4412	2
42	-5.4283±j1.8453	-5.4285±j1.8453	2
43	-3.4051±j0.0377	-3.4164±j0.0563	2
44	-2.5164±j0.0259	-2.4581±j0.0360	2
45	-0.4757±j0.3513	-0.4743±j0.3438	2
46	-0.1111±j0.0715	-0.1177±j0.0655	10
47	-0.5404±j3.5016	-0.5398±j3.5023	10
48	-0.5057±j3.0886	-0.5035±j3.2158	10
49	-0.2293±j0.2118	-0.2290±j0.2105	10
50	-0.2234±j0.1862	-0.2248±j0.1895	10
51	-14.7535±j0.0168	-14.7534±j0.0168	12
52	-0.5463±j2.5677	-0.5412±j2.5714	12
53	-3.5785±j0.3516	-3.5776±j0.3479	12
54	-0.2597±j0.6131	-0.2598±j0.6212	12
55	-3.2566±j0.0992	-3.2685±j0.0838	12
56	-0.2280±j0.2002	-0.2277±j0.1999	12
57	-0.2101±j0.1753	-0.2101±j0.1754	12
58	-0.0847±j0.0111	-0.0873±j0.0107	12
59	-0.2176±j0.1679	-0.2176±j0.1679	12
60	-0.6100±j4.0835	-0.6101±j4.0833	13
61	-0.5490±j2.4876	-0.5425±j2.4837	18
62	-2.3482±j0.8690	-2.2503±j1.1076	18
63	-3.5353±j0.4571	-3.5384±j0.4601	18

TABLE III
EXACT COMPUTATION OF THE RELEVANT DYNAMICS

Mode nb.	Modes with new methodology	Modes with Arnoldi method
1	-50.0394±j7.1054e-15	-50.042±j0.0001
3	-22.0665±j1.1181e-15	-22.0904±j0.0047
62	-2.3482±j0.8690	-2.2503±j1.1076

TABLE IV
MACHINES WITH HIGHEST PARTICIPATION IN MODE 5

Mac.	Rel. Part. (%)	Phase r. evenc. δ (deg)
G7	12.0	177.8
G8	100	173.5
G6	97.6	-79.7
G4	8.7	-34.6
G2	86.5	11.5
G3	87.3	11.3
G5	80.6	0.0

TABLE V
MACHINES WITH HIGHEST PARTICIPATION IN MODE 27

Mac.	Rel. Part. (%)	Phase r. evenc. δ (deg)	Rot. part	D-axes part.
G1	100	0.0	0.0022	0.4650
G9	30	-40.9	0.0012	0.1259