

# Optical communications : a key technology for telecommunication networks. History, present and possible future

Michel Joindot

Laboratoire Foton / CNRS UMR 6082 Lannion





# The basic research period.

November 26<sup>th</sup> 2015

- Thirty years of research about the « bricks » which are needed in any transmission system.

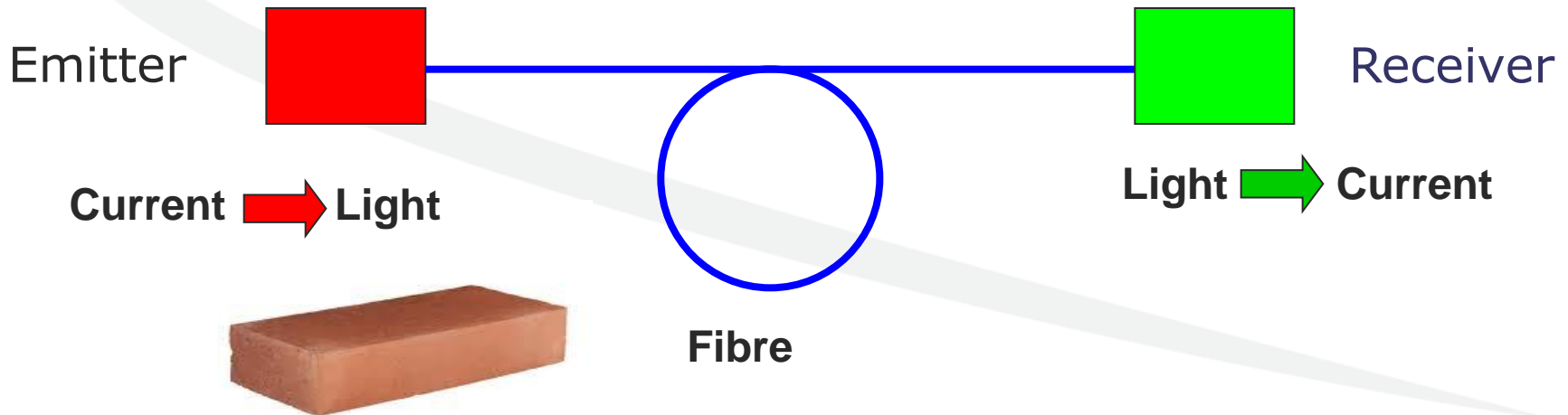

- The main challenges
  - Optical fibre: achievement of losses compatible with the requirements of a transmission system. NTT Japan-**1978**.
  - Optical fibres: make the connection of single mode fibres possible. First connectors in **1978**.
  - Semi conductor lasers: achievement of reliable lasers operating at ambient temperature.  $10^6$  hours-**1976**-Bell Labs
  - Amplification? The practically usable solution will come only in **1995**.

- Some important events:
  - 1953: the first maser (NH<sub>3</sub>) by C. Townes and J. Gordon
  - 1958: C. Townes (Nobel 1964) et A. Schawlow (Nobel 1981) establish laser theory. N. Basov et A. Prokhorov (Nobel 1964), en URSS, achieve the same results.
  - May 1960: T. Maiman builds the first « optical maser » (à rubis at 694 nm), called « laser ».
  - December 12 1960: the first gas laser by Ali Javan (He-Ne at 1153 nm)
  - 1962: Bernard and Durauffourg's law about lasing condition in a semi-conductor.
  - 1962: the first semi conductor laser at General Electric (R. Hall).



# Optical fiber (1): the multimode fibre

Step index fibre. Large dimensions compared to wavelength (core diameter 100 to 200  $\mu\text{m}$ ). Geometrical optics is valid.

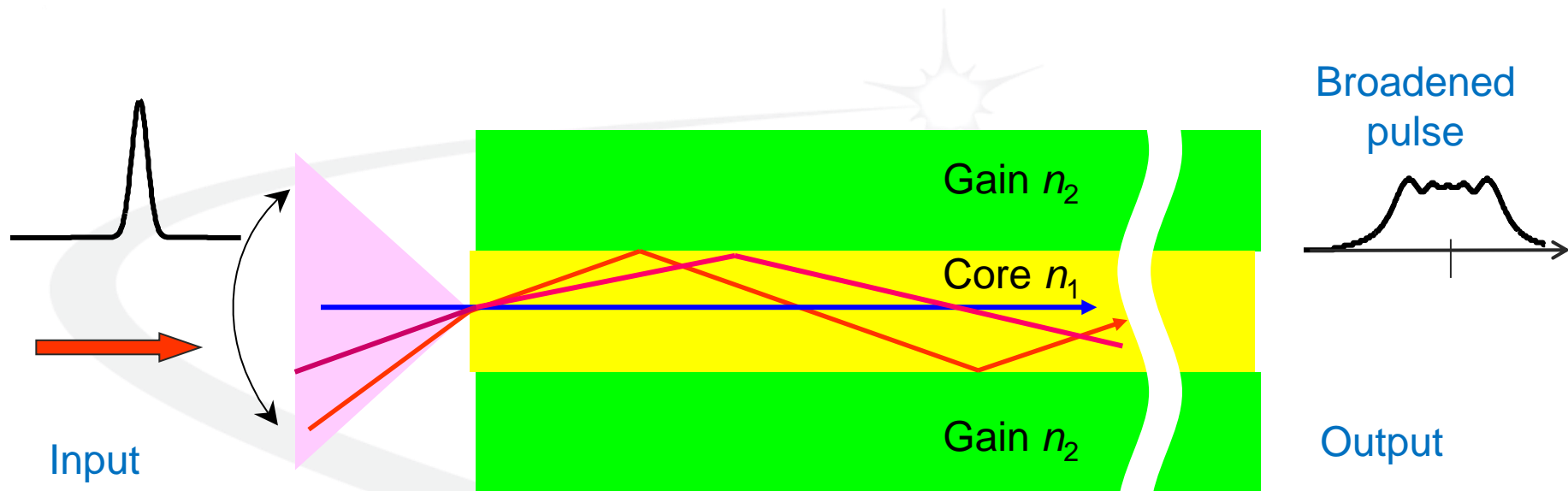

Interference between paths with different delay result into impulse broadening  
And then performance degradation. Multimode fibre bandwidth is then strongly  
Limited and so is transmitted bit rate.

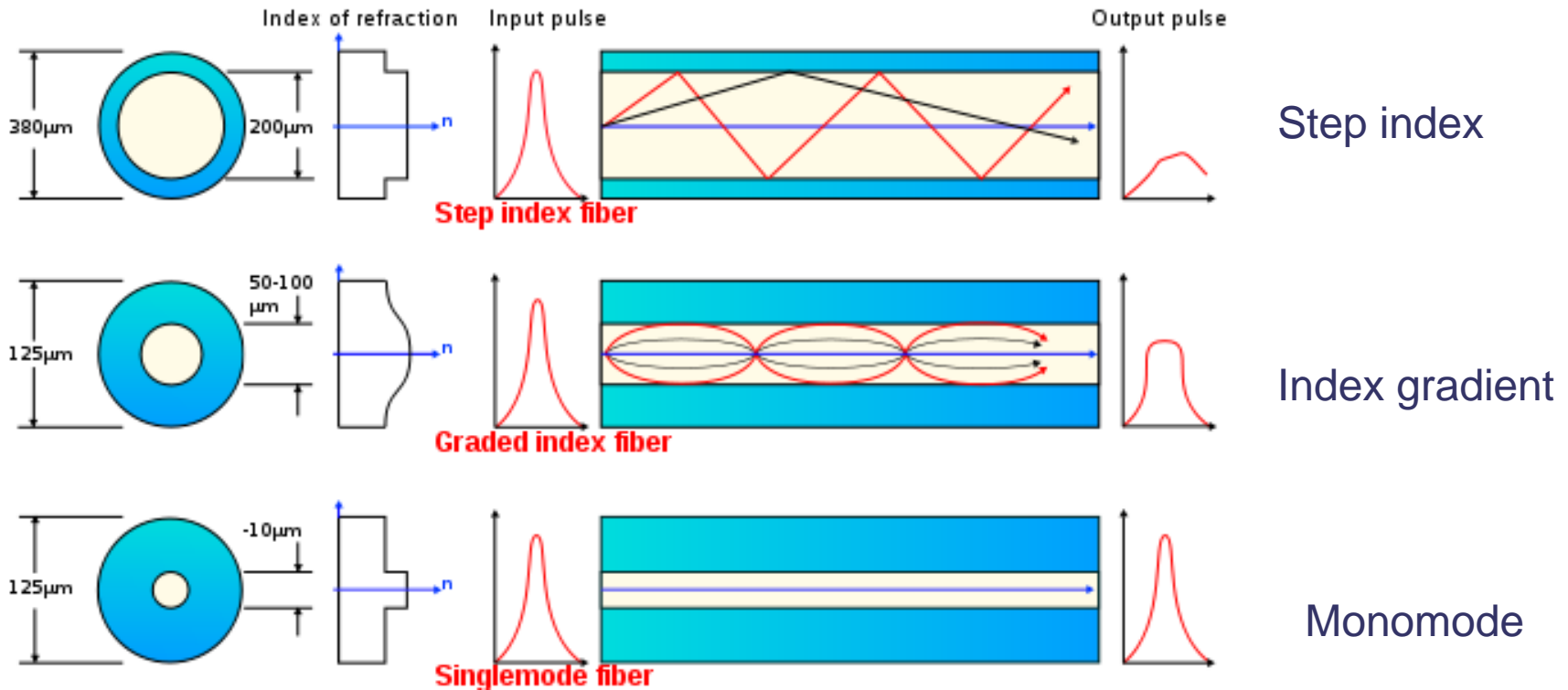

Propagation in mono-mode (or single-mode) fibres requires waveguide theory. Optical transmission networks use only single-mode fibres.

- 1841: D. Colladon demonstrates light guiding in a water at Geneva.
- 1953: C.S. Van Heel (Delft University) publishes the first paper about a fibre with gain and core (in dutch).
- 1959: American Optical draws the first monomode fibre.
- 1964: C. Kao (STL) announces that less than **20 dB/km** is possible. Publication of a paper in Proceedings of IRE.
- 1967: Corning begins to draw fibres. Losses remain high, but the project goes on with R. Maurer as leader.
- 1968: C. Kao et M. W. Jones measure **4 dB/km in massive silica**.
- 1970: Corning reaches **17 dB/km** (titanium doped glass) at 633 nm. Results are confirmed by British Post Office.
- 1972: Corning obtains **4 dB/km** with a Ge doped multimode fibre.
- 1978: NTT produces the first **monomode fibre** with an attenuation of **0.2 dB/km** at 1550 nm.

Charles Kao



<http://www.ece.umd.edu/~davis/optfib.html>



# Attenuation in optical fibres

Evolution of loss over the 1970-80 period (source: Sudo)

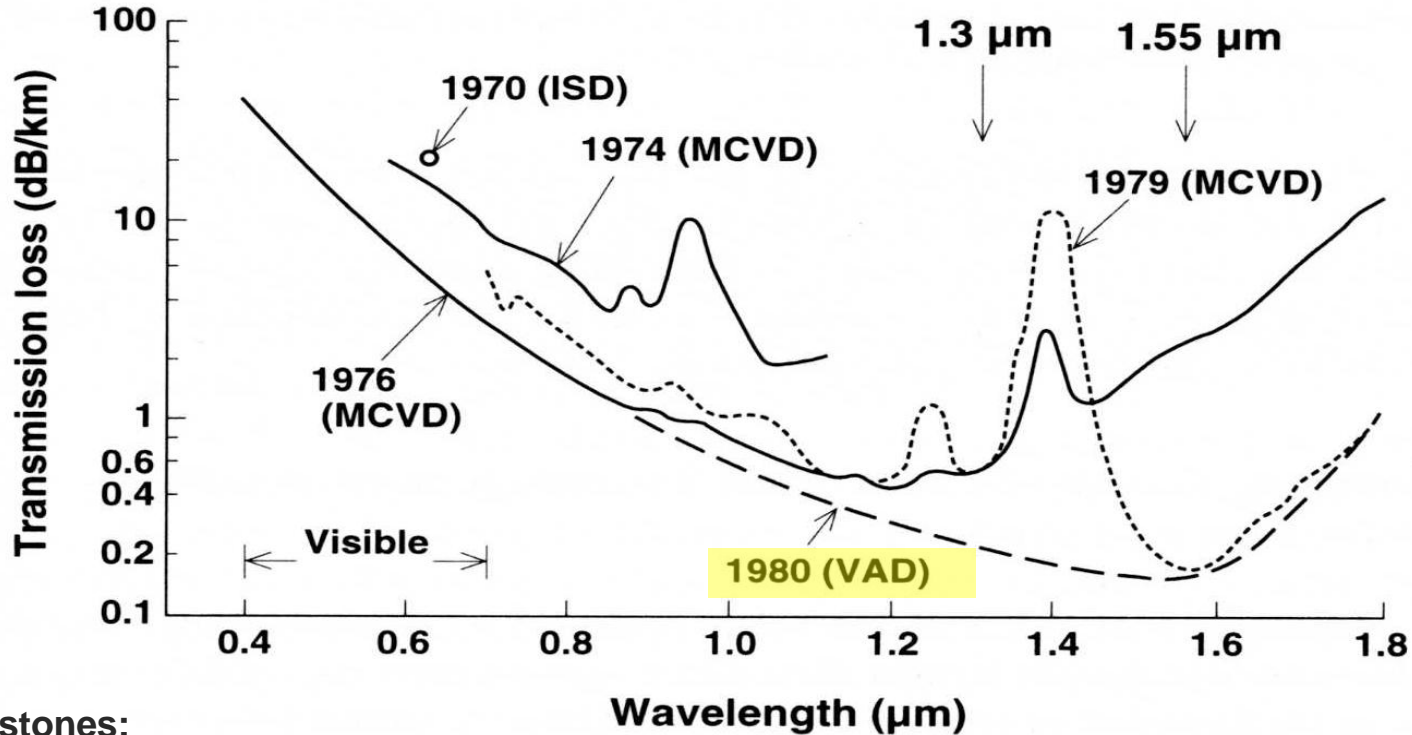

## Milestones:

- 1970 : Corning : 17 dB/km, single mode fibre at 633 nm
- 1978 : NTT : 0.2 dB/km, single mode fibre at 1550 nm.

Source : *Présentation JNOG 2009 Lille, J. C. Simon*

Propagation velocity depends on the wavelength: the spectral components of an impulse do not travel at the same speed, which causes impulse broadening and then inter-symbol interference.

Chromatic dispersion is characterized by the “dispersion parameter”  $D$ .  $D=17$  ps/nm.km for the so called “single mode standard fibre” (SSMF).

## MAXIMUM DISTANCE OVER STANDARD FIBRE (NRZ CODE)

2.5 Gbit/s	1000 km
10 Gbit/s	60 km
40 Gbit/s	4 km
100 Gbit/s	0.6 km

- Free space communication
  - A lot of experiments conducted in the sixties with gas lasers as sources: CNET in Lannion (Brittany) was one of the actors.
  - 108 Mbit/s over 23 km near Lannion (world record at that time).
  - Because of the fading due to rain or fog, optical free space communication is not compatible with the availability requirements of a transmission system.
  - Optical fibre will be a much more convenient transmission medium.

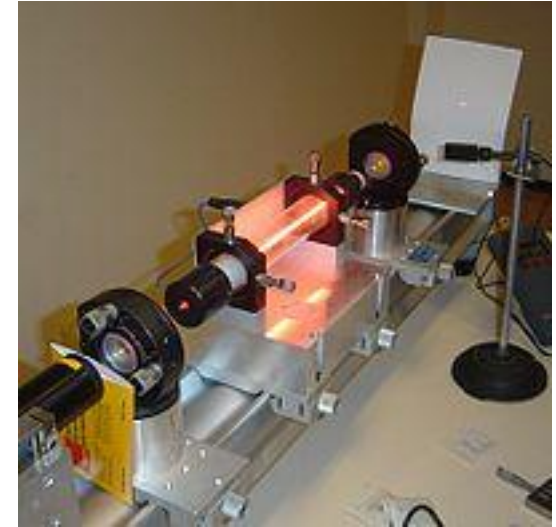

# From the first optical systems to the advent of Wavelength Division Multiplexing (1980-1995)

- The first optical systems appear at the beginning of the 80s.
- They are basically digital transmission systems with a bit rate of 34 or 140 Mbit/s per fibre, and about 40 km between repeaters.
- At that time, long distance networks rely on two technologies:
  - Coaxial cable (140 and 560 Mbit/s per coaxial pair) with a distance between repeaters of about 4 km at 140 Mbit/s and less than 2 km at 560 Mbit/s.
  - Radio links (typically 140 Mbit/s channels per system), with a distance between repeaters of about 50 km.
  - The objective of telecom operators was an equal share of traffic between cable and radio network, in order to improve availability.

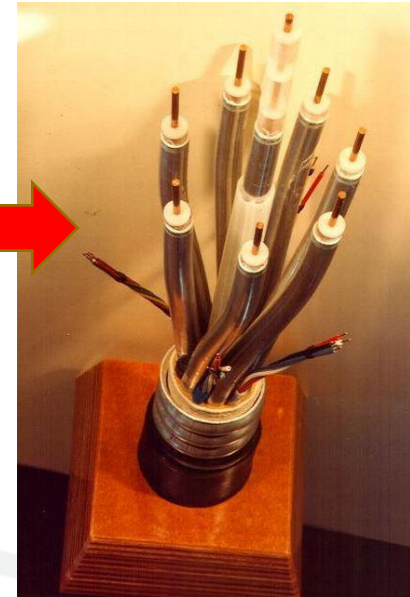

- Optical transmission outperforms coaxial cable in terms of operational costs and transmission quality ;
- But it does not exhibit any determinant advantage compared to radio : bitrate and regeneration span are equivalent.
- Coaxial cable links will then be eliminated while optical and radio transmission will coexist in the network.



November 26<sup>th</sup> 2015

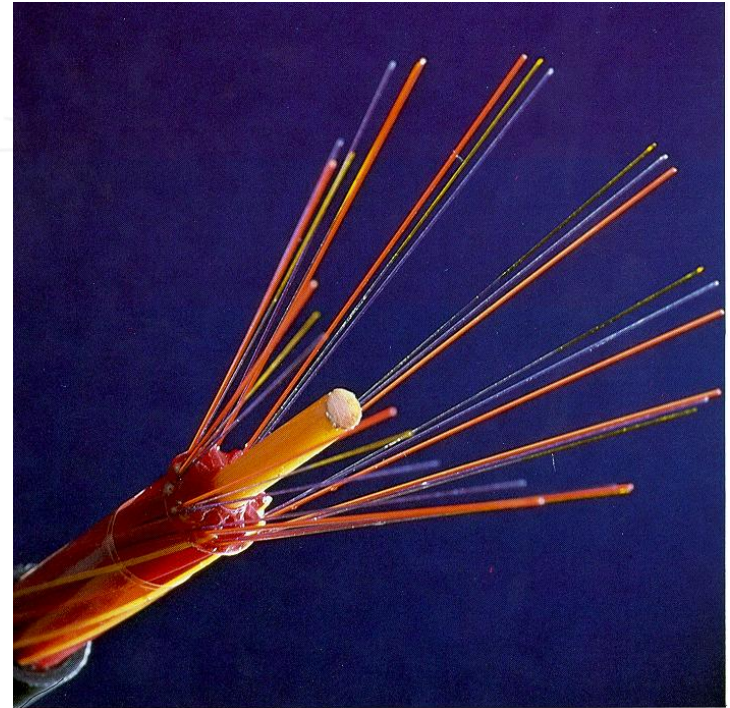

Source: Orange Labs

Radio tower in Lannion  
Source: <http://www.hertzien.fr>

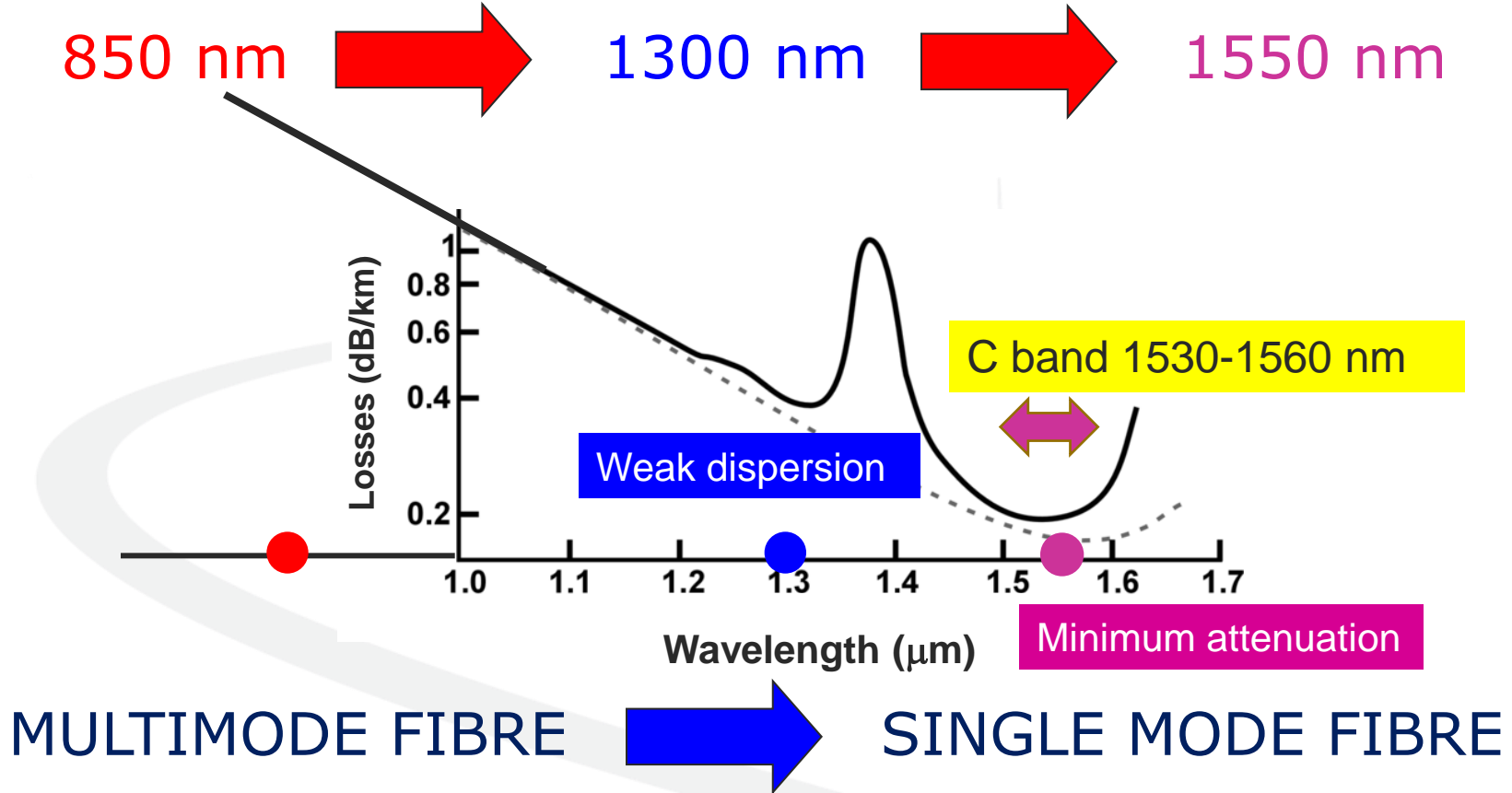

Intensity modulation combined by direct detection in a photodiode is the unique technology.

- Sensitivity of direct detection receivers is basically limited by thermal noise of electronics.
- Coherent reception can provide.
  - A higher sensitivity;
  - A much larger choice of possible modulations.
- Research in this domain has been very active between 1980 and 1990, with a lot of theoretical as well as practical results, but no commercial system occurred.

*CNET Lannion 1986 : Monomode project*

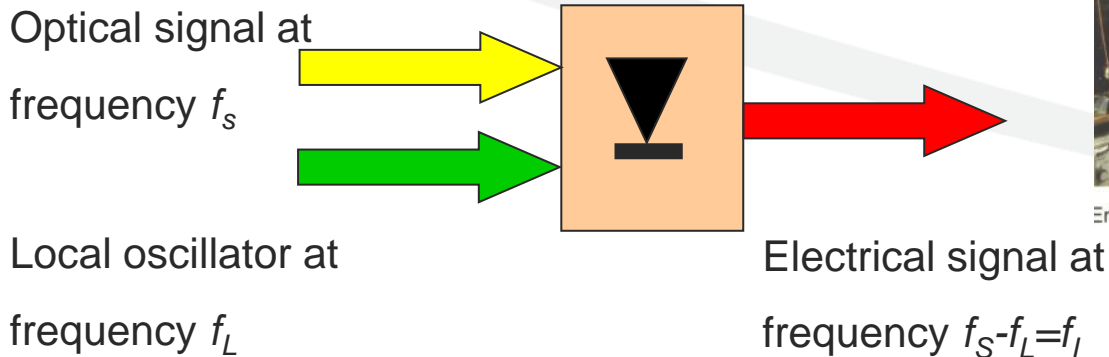

optique en ligne.

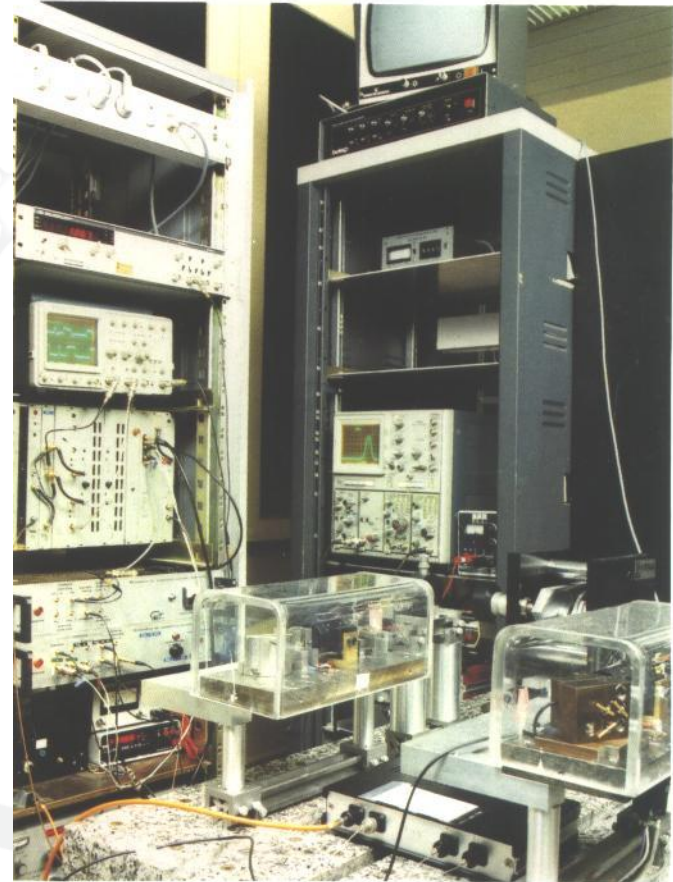

Ensemble expérimental de la phase III.



- First high capacity systems appear at the beginning of the 90s.
  - They are digital systems, with a bit rate of 2.5 Gbit/s and a regeneration span of 100 km;
  - They use directly modulated DFB lasers at 1550 nm;
  - The transmitted bit rate remains very small compared to the potential capacity of a single mode fiber;
  - Optical reach is only limited by losses, dispersion does not play any significant role, as well as non linear effects;
  - Optical fiber is viewed at this time as an "ideal" transmission medium, just attenuating the signal without distorting it like radio links affected by selective fading due to multipath propagation.



An « interurban network » is implemented between 1990 and 1993, based on 2.5 Gbit/s systems with an average regeneration span of about 80 km (around 20 dB loss).

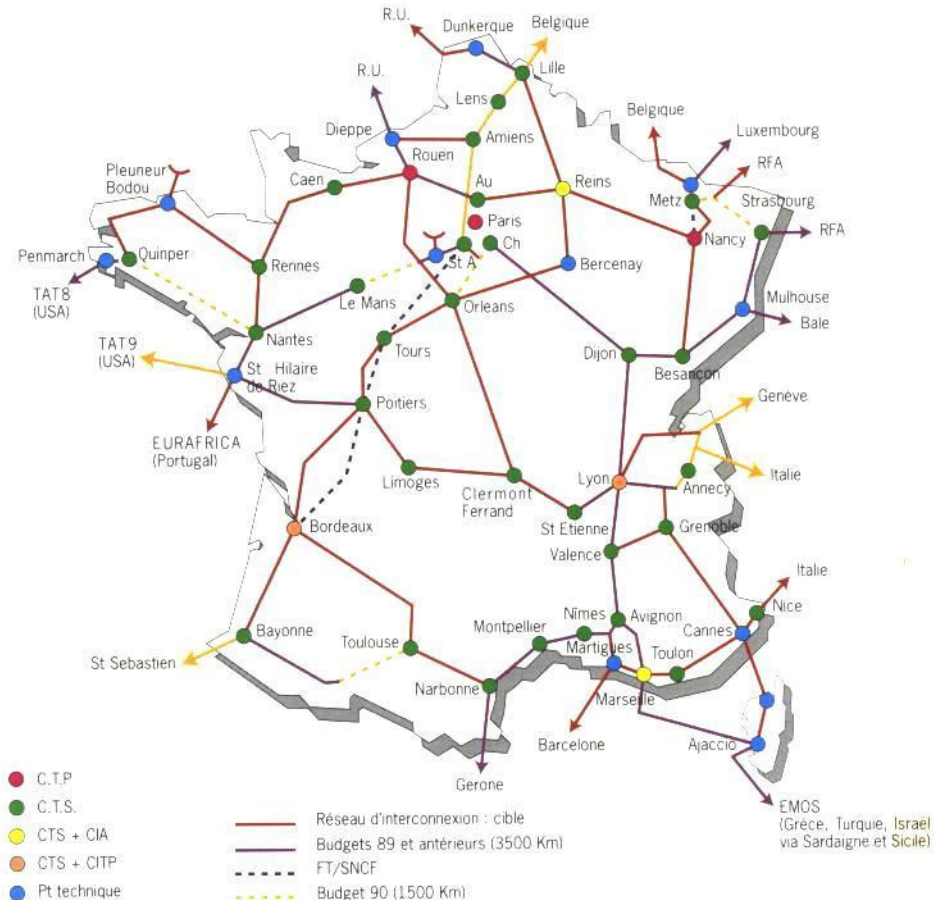

Source : *Commutation et Transmission 1989*

# Wavelength Division Multiplexing (WDM)

- Around 1995, the not yet solved amplification issue finds a solution with the advent of the **Doped Fibre Amplifier**;
- Doped Fiber Amplifier amplifies the channels without interference between them;
- It makes the implementation of *Wavelength Division Multiplexing (WDM)* possible;
- This approach is extremely interesting economically because the amplifier cost is shared among the channels;
- Its makes gradual investment possible: "Pay as you grow".

*Several channels use efficiently the available bandwidth. They are amplified in a common amplifier*

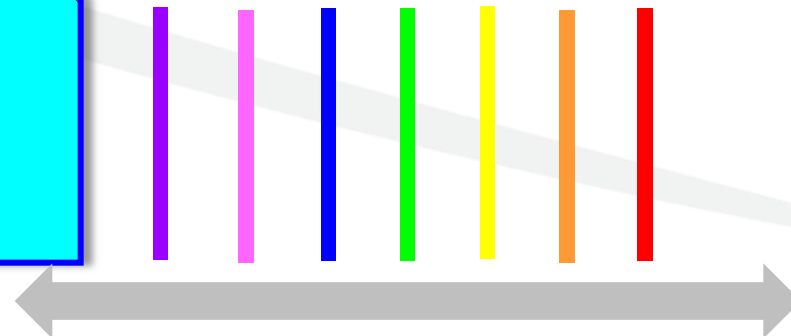

Fibre bandwidth

- Diode pumping (1480 nm, and later 980 nm)

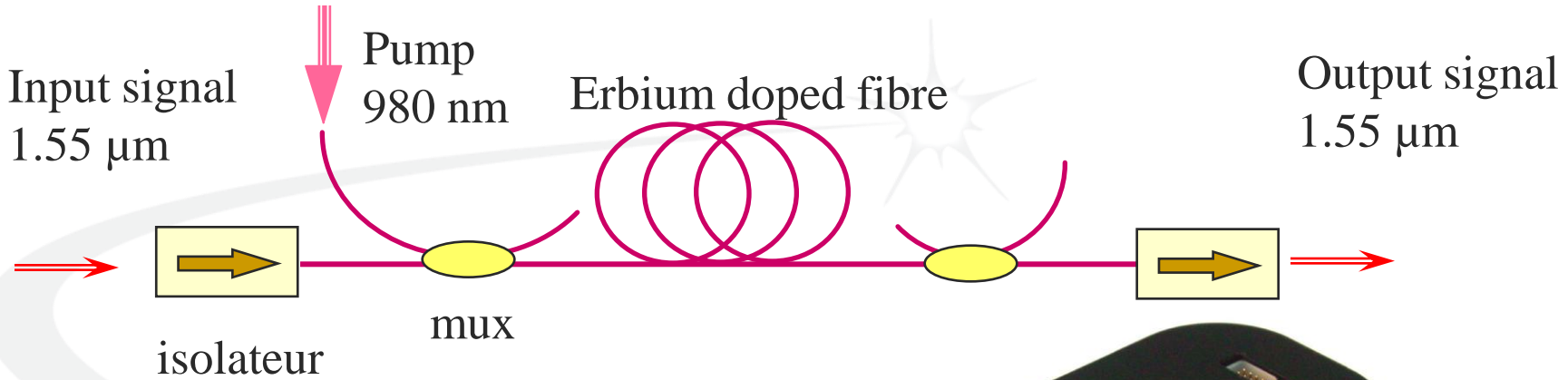

Commercial products after some years

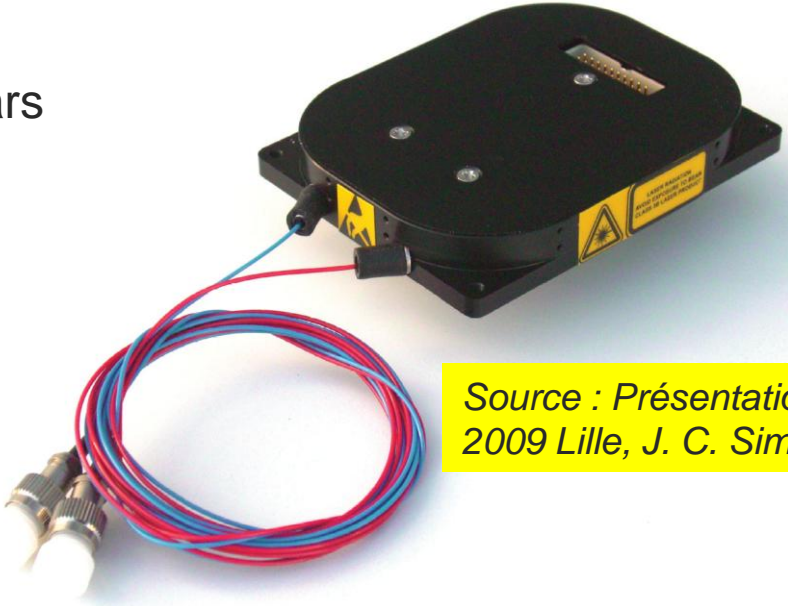

Source : Pr sentation JNOG 2009 Lille, J. C. Simon

# Architecture of a WDM system

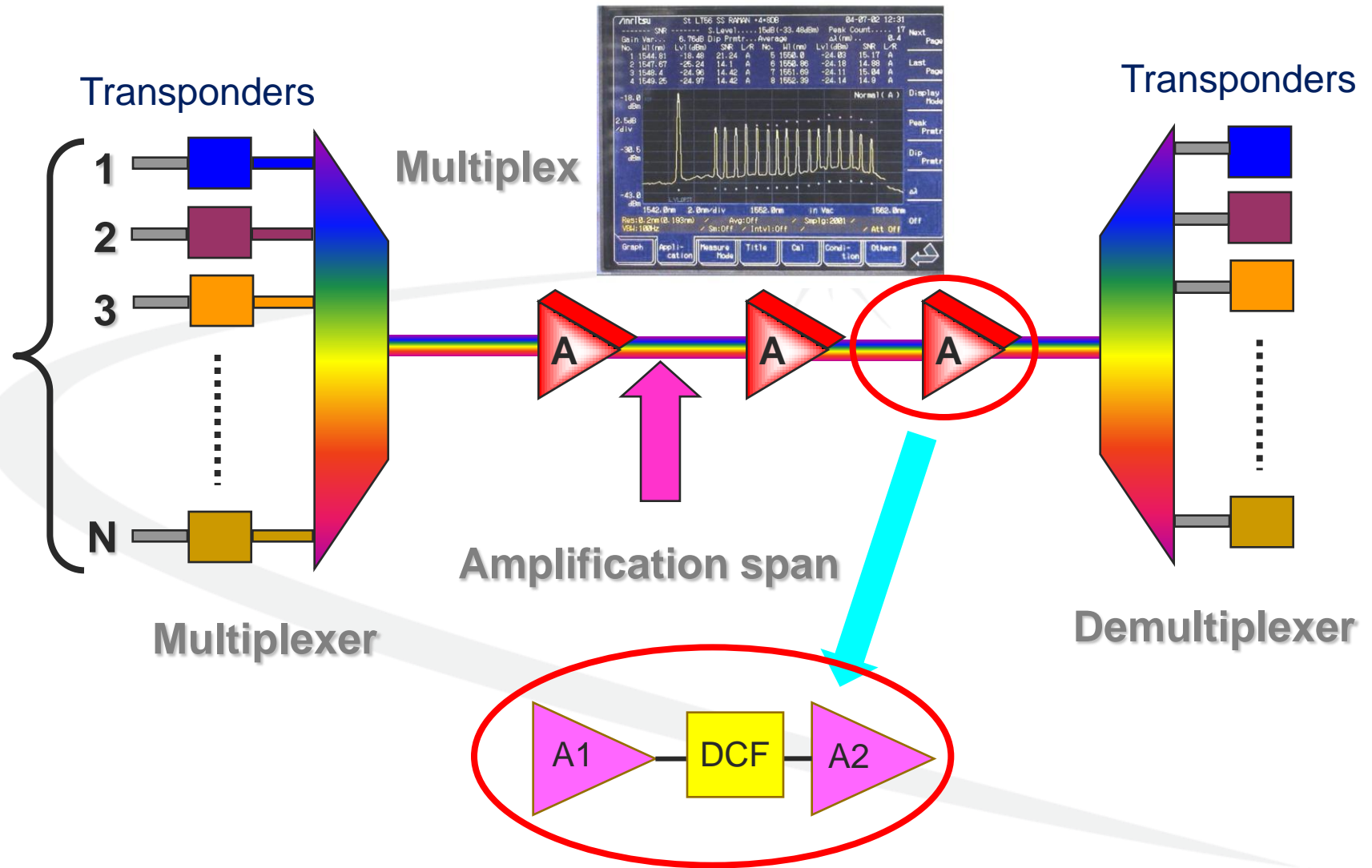

*WDM opens the way to "transparent" networks.*

November 26<sup>th</sup> 2015

The channel (also called “wavelength”) opens the way to a new network architecture.

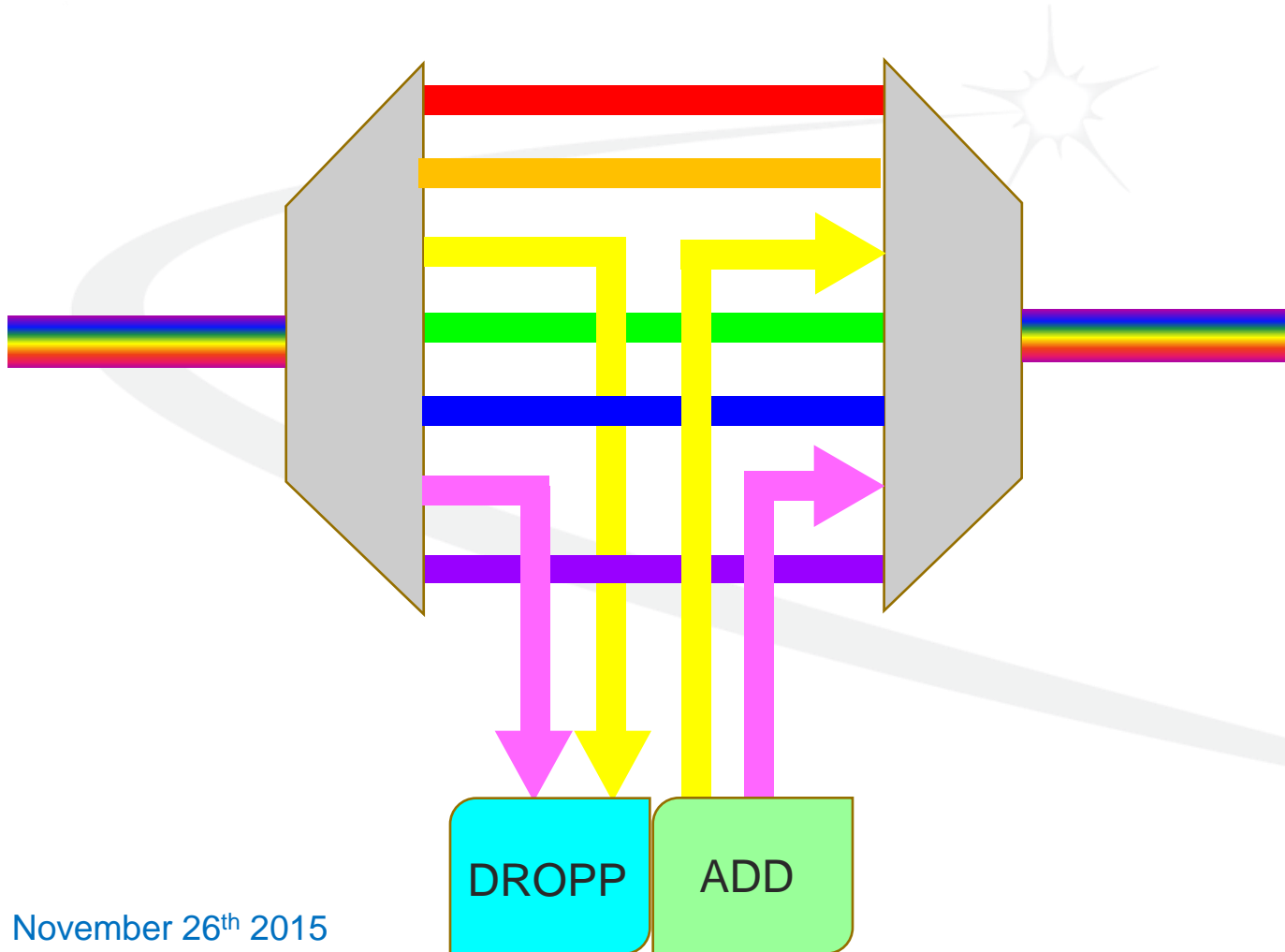

- Association of amplification and WDM results into a complete revolution in transmission systems as well as in networks architecture.
- In counterpart replacing regenerators by amplifiers leads to impairments accumulation (back to the analogue era!)
  - **Amplifiers noise** accumulation limits the transmission distance without regeneration;
  - **Chromatic Dispersion** accumulation induces a signal distortion which grows with distance;
  - **Non linear effects**: 100 mW in a  $80 \mu\text{m}^2$  core area correspond to a power surface density of  $1,25 \text{ kW/mm}^2$  !
  - **Polarization Dispersion Mode (PMD)** induces multipath effects which can be strongly limiting on some "old" fibres.
- **Fibre cannot be viewed as an "ideal pipe" which would transmit signals without any distortion.**

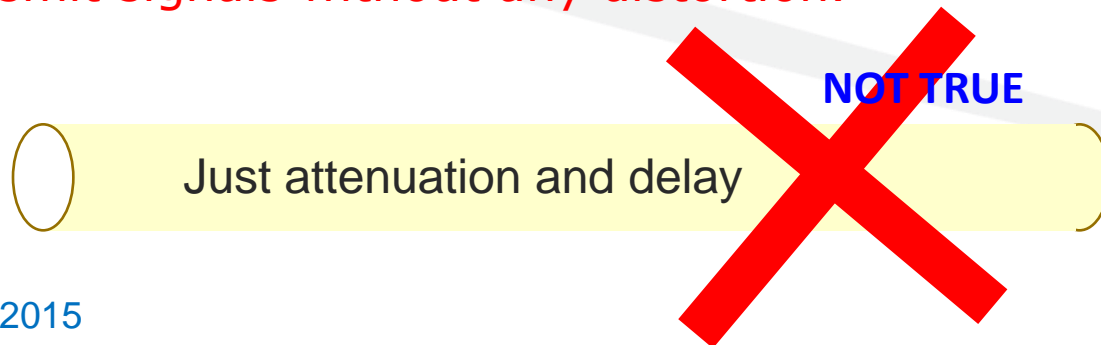



A very special fibre...

From J. C. Simon's paper  
at JNOG 2009 in Lille

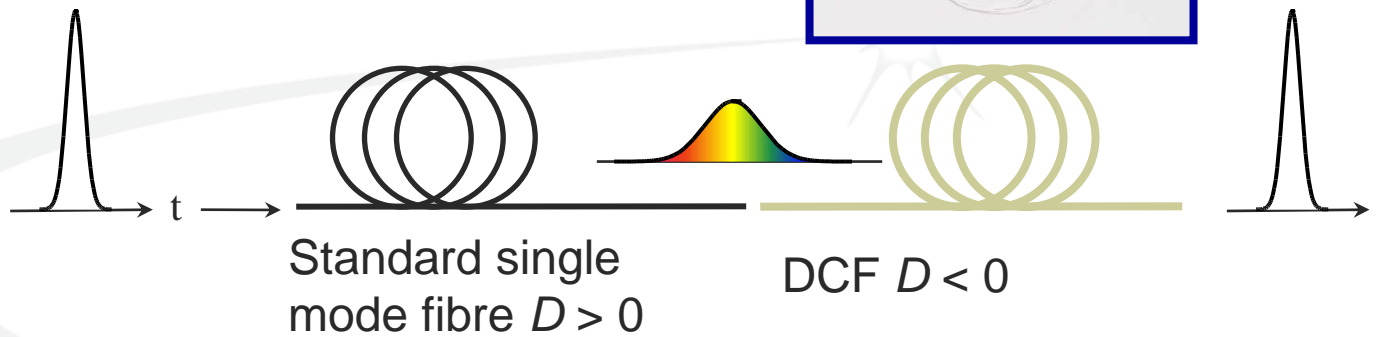

Eye diagram

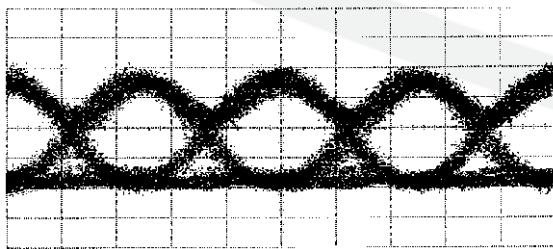

Emitting side

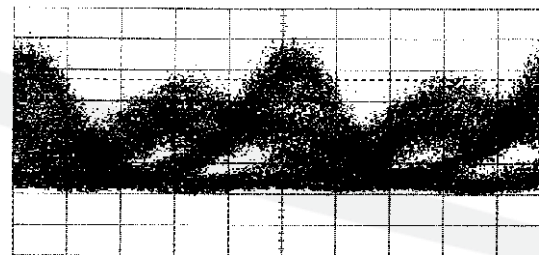

Before compensation

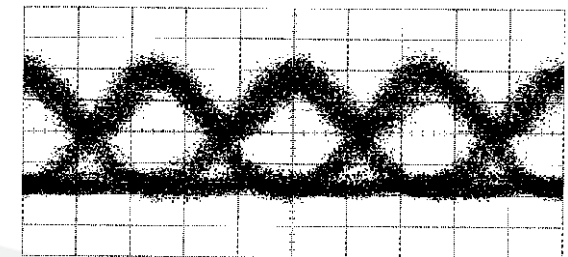

After compensation

- Besides the C band corresponding to the minimum attenuation, other bands have been proposed. The most easily usable is the L band (1565 nm-1625 nm), and a lot of experiments have been carried out with both bands. Nevertheless, the absence of amplifiers covering C and L bands together limits the interest of this approach.
- **Commercially available WDM systems use mainly C band, the objective is to fill it as much as possible.**

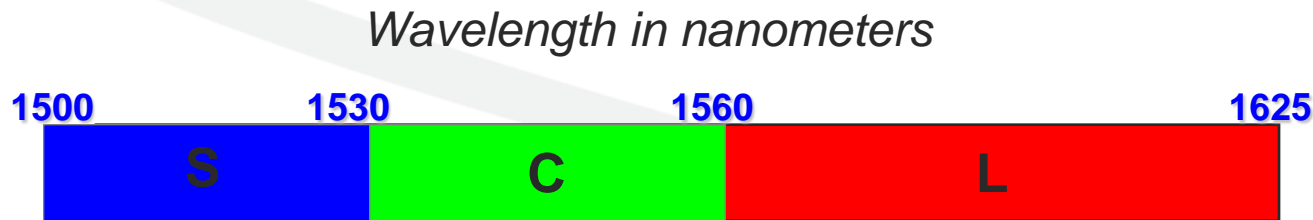



# Optical technology in intercontinental networks

November 26<sup>th</sup> 2015

- Up to the Second World War, telecommunications between continents rely only on HF radio with a very limited capacity (some tenths of telephone circuits between France and USA in the 30s);
- Transatlantic cables have been in use since the second half of the 19<sup>th</sup> century, but they are exclusively telegraphic cables (first cable laid on August 5<sup>th</sup> 1868 between UK and USA);
- The first telephone cable (TAT1) is put in service in September 1956: it transports 36 telephone circuits, repeaters are placed every 9 km along the 3600 km route. Underwater electronic devices require a reliability which could not be reached before. 6 other coaxial cables will be laid.



<http://blog.sciencemuseum.org.uk/insight/tag/tat1>

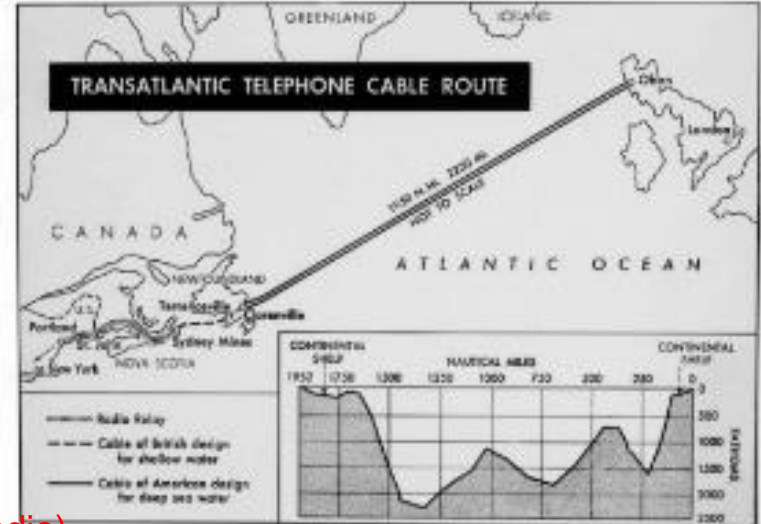

UK North America : in 1930 2000 telephone calls/year (HF radio)  
TAT1 : 220000 calls in the first operation year

November 26<sup>th</sup> 2015

- 1988 : the first optical cable (TAT 8) is laid. It contains two fibre pairs and carries 280 Mbit/s per pair (i.e 40000 telephone circuits), regeneration span is 40 km. Wavelength is 1300 nm. Three other cables will be laid, using the 1550 nm band.

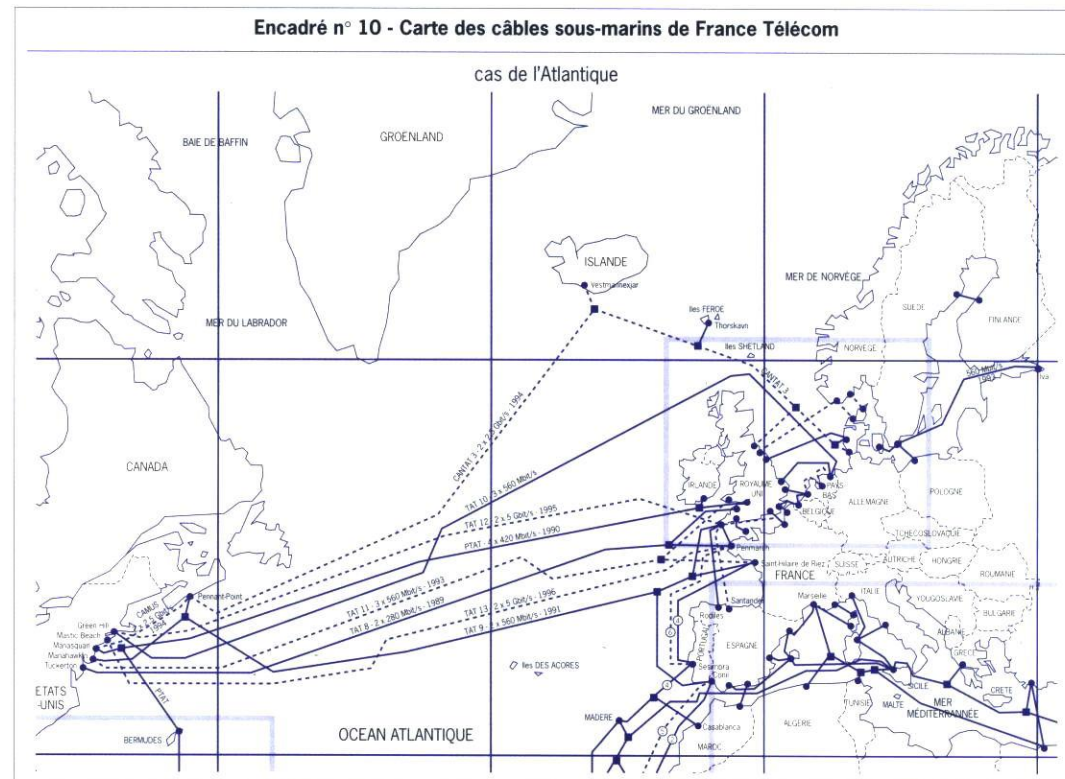

From the memento n°3 of the Scientific Board of France Telecom 1994.

Les communications optiques à France Telecom.

J. Y. Serreault et A. Hocquet

- At the beginning of the 60s, satellite provides a new and very efficient intercontinental transmission technique, allowing speech, but also TV transmission (First transmission between Andover and Pleumeur-Bodou on July 11<sup>th</sup> 1962) ;
- First geostationary satellite put in service in 1965;
- Capacity of satellites will increase. In 1970, 9000 telephone circuits and 12 video channels, in 1980 18000 telephone circuits and 24 video channels, in 1990 33000 telephone circuits and 4 video channels.



- 1996 : TAT 12 et 13 are the first amplified submarine systems. Capacity 5 Gbit/s per fibre pair;
- 2001 : TAT 14 is the first WDM submarine cable (64x10 Gbit/s, i.e 9700000 telephone circuits).

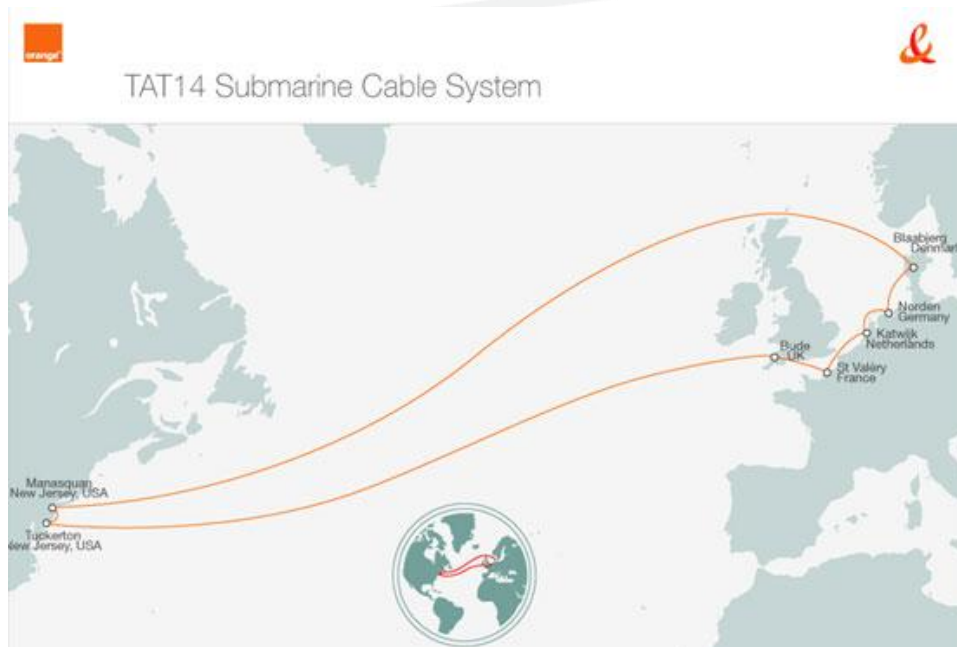

*From the public Orange site*



*From <http://www.lotravocean.fr>*

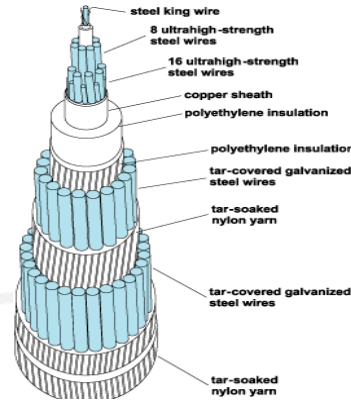

Optical cables outperform satellite in terms of capacity and become the unique technology for intercontinental networks.

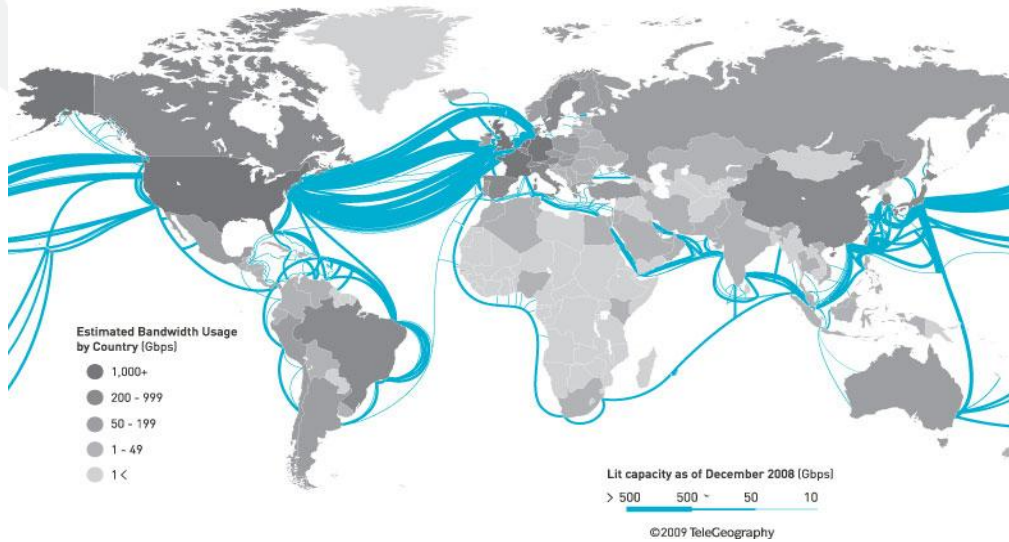



- ✓ At the end of the nineties, **optical transmission** has become **the unique technology** in backbone as well as metropolitan networks.
- ✓ **A fibre infrastructure** is laid over which successive generations of systems will be installed.
- ✓ **WDM technology** will provide a continuously increasing capacity over a roughly unchanged infrastructure and accommodate a dramatically increasing traffic.

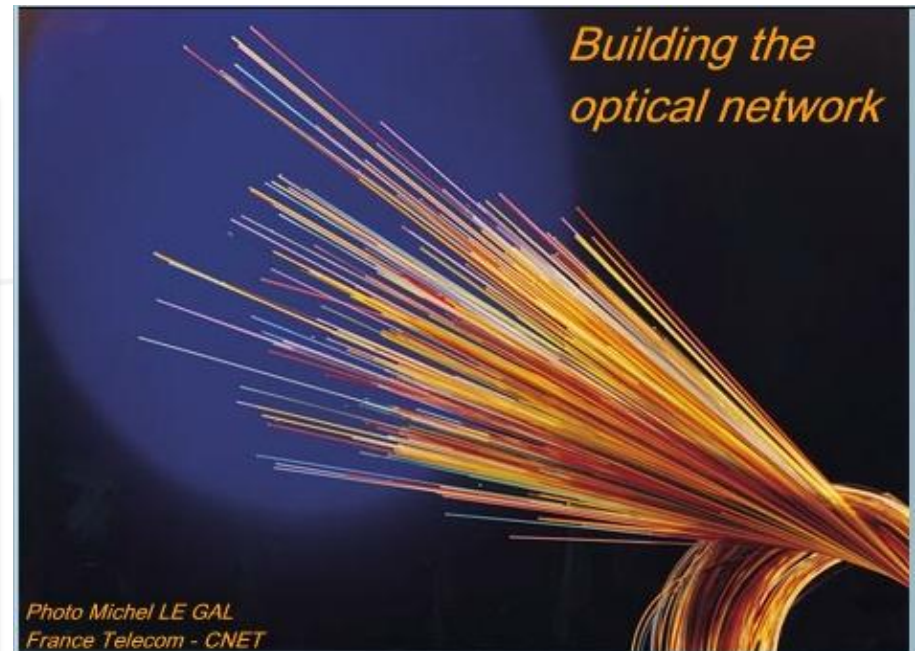



Since 1995,  
capacity explosion

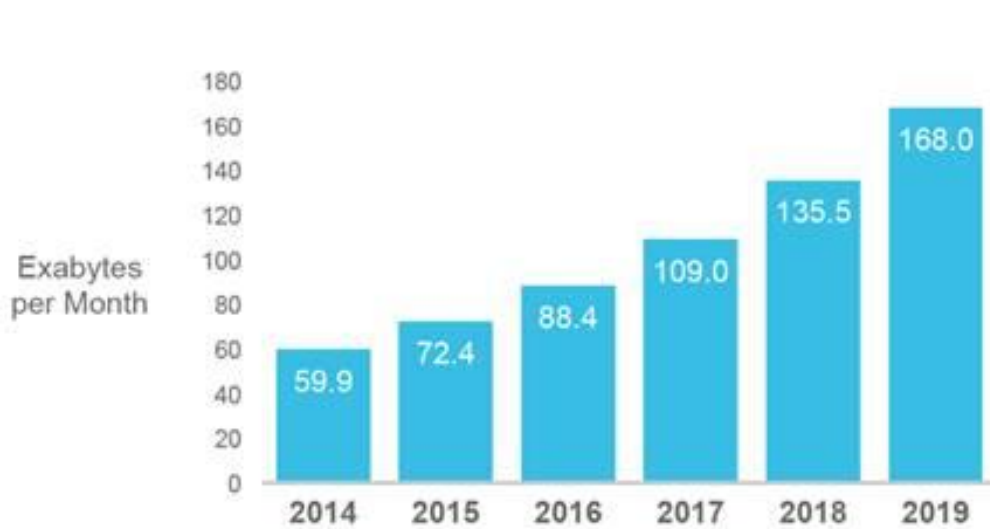

23% CAGR 2014–2019

Source

[http://www.cisco.com/c/en/us/solutions/collateral/ser vice-provider/visual-networking-index-vni/VNI\\_Hyperconnectivity\\_WP.html](http://www.cisco.com/c/en/us/solutions/collateral/ser vice-provider/visual-networking-index-vni/VNI_Hyperconnectivity_WP.html)



- WDM increases the potential capacity of already laid fibres and allows facing traffic increase without any additional infrastructure, which is a considerable gain for the operators:
  - First 2.5 Gbit/s per channel systems are installed in 1995 (4 channels with 8 nm spacing) ;
  - Very rapidly, a smaller channel spacing allows increasing capacity;
  - At the beginning of the 2000s the first 10 Gbit/s per channel systems occur, with a channel spacing of 100 and later 50 GHz;
  - Core networks will be built with such systems;
  - The optical reach increases as well as capacity;
  - Available systems provide an overall capacity of 800 Gbit/s (80x10 Gbit/s with 50 GHz spacing) over an optical reach of 2000 km.

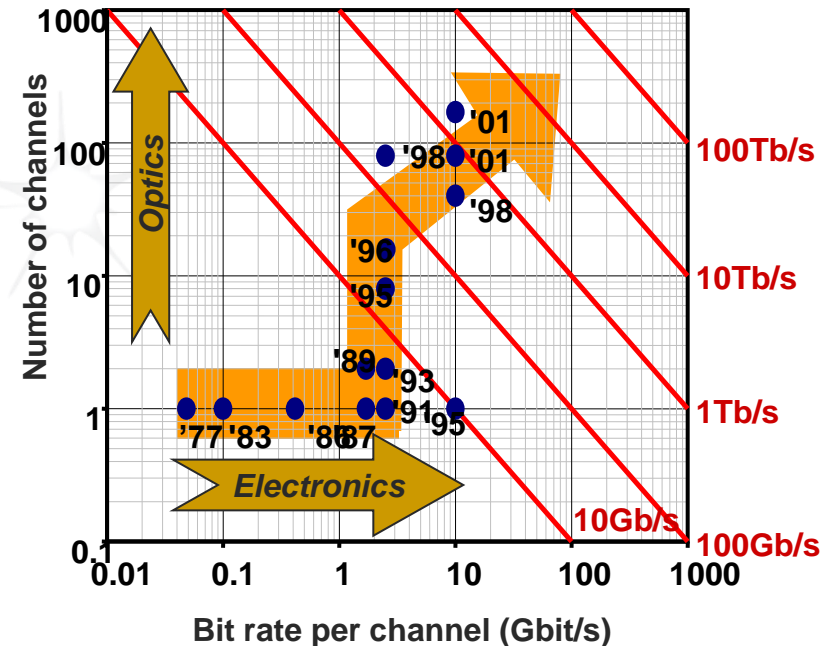

From H. Kogelnik ECOC 2004

Potential capacity of one fiber multiplied by more than 300 in less than 20 years

- Sea Me We 3 (1999) : Europe Middle East Asia (39000 km, two fibre pairs, 8x2.5 Gbit/s per pair) ;
- **FLAG Atlantic 1 (2001): transatlantic, 2.4 Tbit/s per fibre pair**
- Apollo (2002) : transatlantic, 4 fibre pairs, 80x10 Gbit/s per pair.
- **Sea Me We 4 (2005) : Europe Middle East Asia (20000 km, two fibre pairs, 64x10 Gbit/s per pair).**

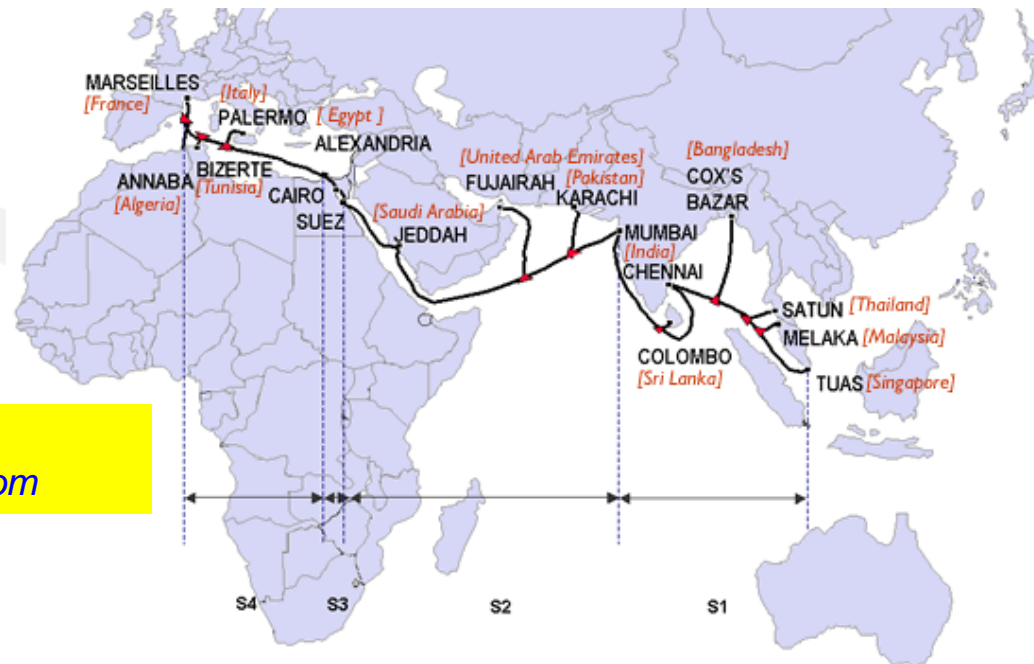

From the public site  
<http://www.seamewe4.com>

- First 100 Gbit/s per channel experiments in 2006, commercial systems in 2010. A capacity of several Terabit/s in C band becomes attainable (80 100 Gbit/s channels with 50 GHz spacing).
- Complex multilevel modulation formats (QPSK, coherent reception with use of cross polarizations);
- Compensation of transmission impairments is provided by digital signal processing performed by powerful electronic devices;
- Optical community use now the notion of spectral efficiency! Spectral resource is no longer unlimited!

bit/s/Hz

Receiver optical part is reduced to demodulation and photo detection

Use of powerful digital signal processing as in radio systems

Analog to digital conversion is a key issue.

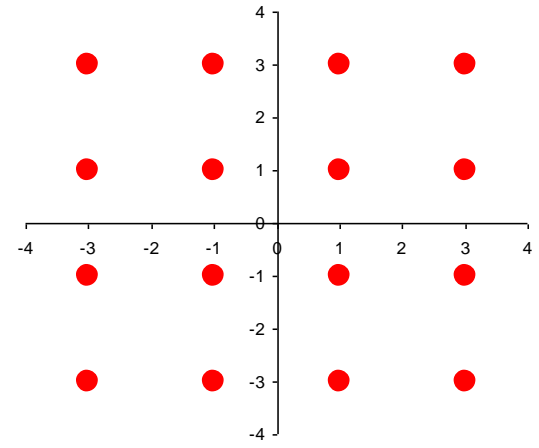
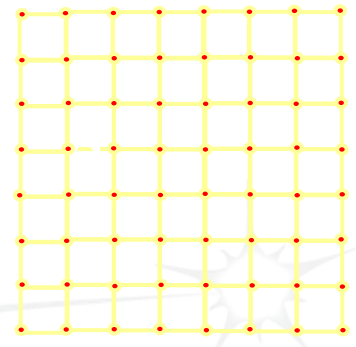
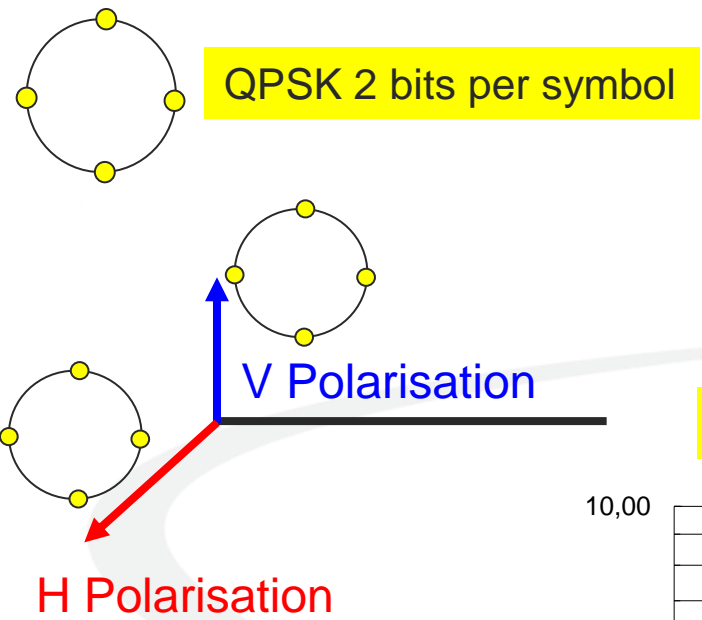

**PDM-QPSK**  
4 bits per symbol  
100 Gbit/s in 25 GHz

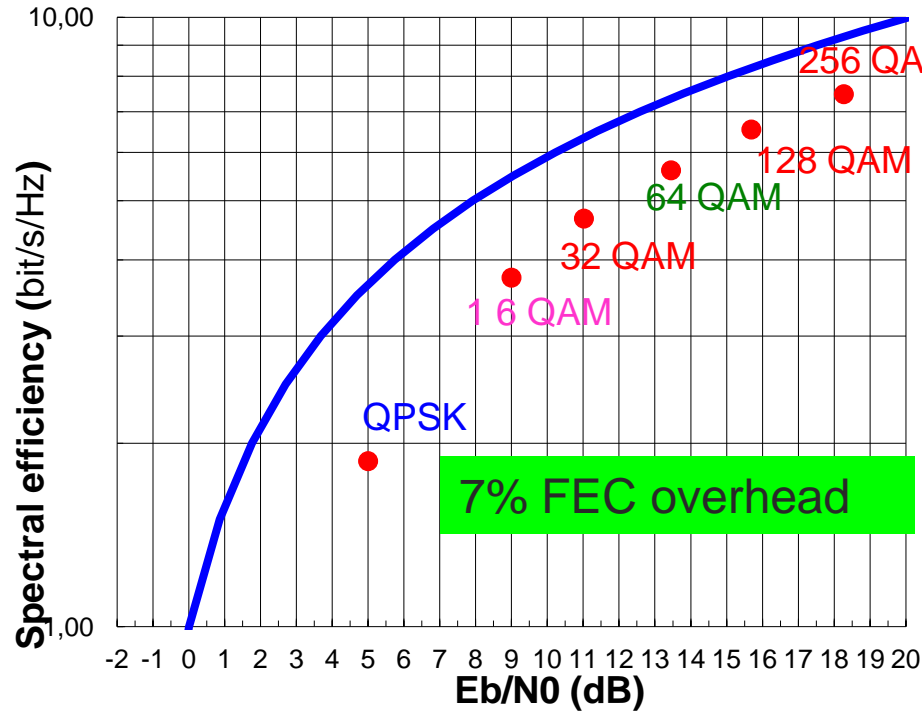

**16 QAM**  
4 bits per symbol

**PDM 16 QAM**  
8 bits per symbol

Source N. Brochier  
Orange Labs

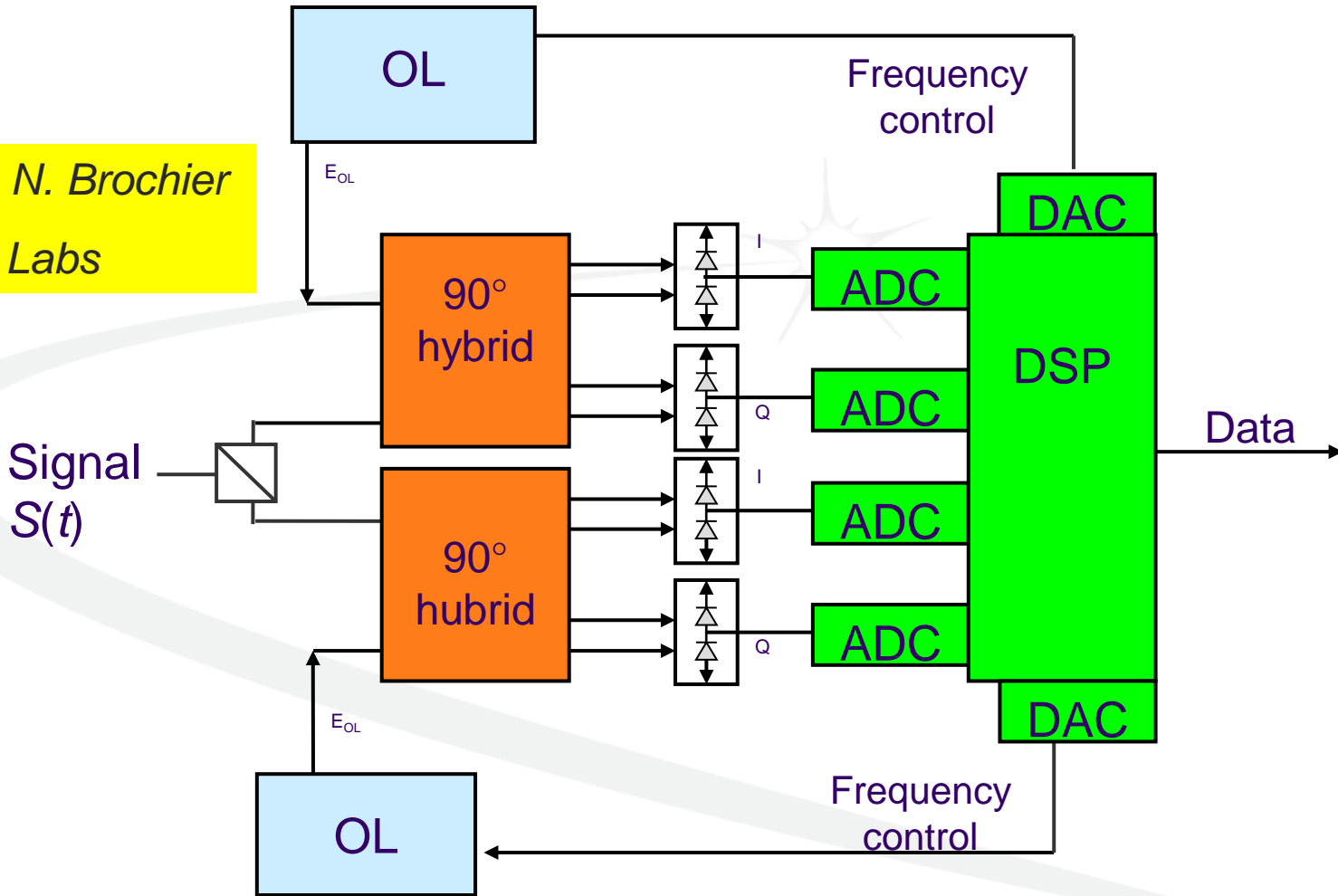

**Digital Signal Processing plays a major role.  
ADC are key components.**



- **100 Gbit/s** PDM 16QAM on a 50 GHz grid (spectral efficiency 4 bit/s/Hz) is now commercially available;
- **Higher channel capacities to face traffic increase** : 400 Gbit/s (factor 4) or 1 Tbit/s (factor 10) as new Ethernet standards?
- What technical solutions for that?
  - More channels (reducing channel spacing or increasing the bandwidth)?
  - Modulation formats with more levels (64QAM, 256QAM...)?
  - Other solutions?

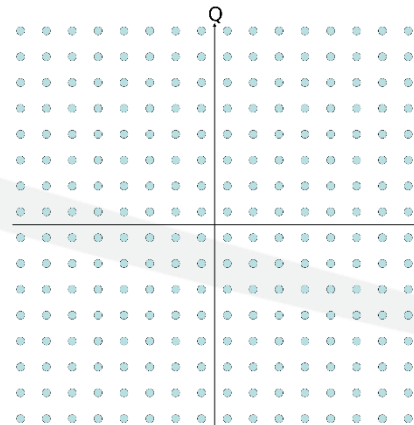

256QAM 8 bit/symbol  
9 dB OSNR more  
than 16QAM

- Noise accumulation. Noise sensitivity increases when the number of modulation levels does. And so does FEC overhead ;
- Non-linear effects which limits the usable power. Large effective area fibres and Raman amplification can relax the constraint;
- Crosstalk. Crosstalk penalty increases when the number of modulation levels does;
- Degradations due to filtering (OADM);
- Laser phase noise;
- Electronics, especially ADC. More and more difficult when symbol rate increases.

**For a given bitrate:**

- Increasing the symbol rate: limits of electronics;
- Increasing the number of levels: modulation is more sensitive.

- Terrestrial core networks rely on fibres (mainly SSMF) which have been laid when WDM did not exist;
- 50 GHz grid is a standard;
- This infrastructure (fibres, amplification spans, regeneration sites, OADM filters) must remain compatible with successive generations of systems which require in particular always higher optical signal to noise ratios;
  - Adding new sites requires investment and additional operational expenses;
  - Advantages of amplified links are reduced;
  - **Complying with ever increasing OSNRs is then more and more challenging;**
  - Nevertheless, this constraint is relaxed in metropolitan networks.
- Compatibility could be achieved up to now (from 2.5 Gbit/s to 100 Gbit/s per channel) through different improvements:
  - More efficient devices (amplifiers, compensation devices);
  - Error correcting coding;
  - Coherent reception and electronic compensation.

Existing network constraints

- Noise accumulation in an amplifiers chain. The noise “wall”.

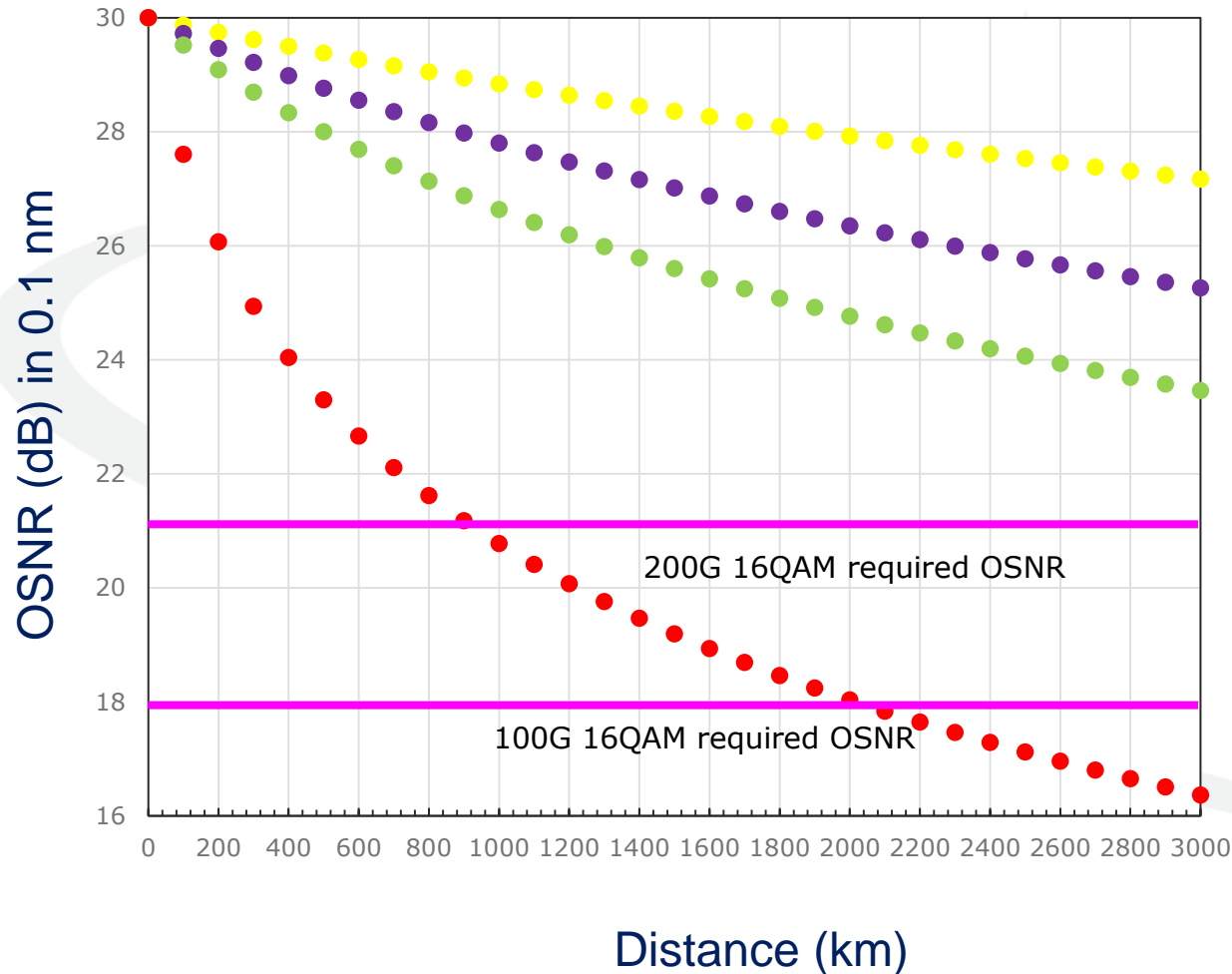

Fibre loss 0.2 dB/km  
 $NF_{amp}=4.5$  dB  
 $SNR_{em}=30$  dB  
 $P_{em}=0$  dBm

Amplifier compensates for span loss.

Amplification span  
100 km  
50 km  
25 km  
10 km

Single carrier modulations:

Bitrate/ch	Modulation	Distance (km)	SE (bit/s/Hz)	Year
100G	PDM QPSK	2000	4	2010
320G	PDM QPSK	5600	2.9	2012
100G	Coded 16QAM	9100	4.93	2013
200G	PDM QPSK/PDM16QAM	1750	4	2013
200G	PDM 16QAM	6600	5	2013
400G	PDM 32/64 QAM	3200	8.25	2013
400G	PDM 16QAM	80	8	2015

- **C+L band**
- **One 400G channel**
- **Non standard fibre**

Beyond 200 Gbit/s in a 50 GHz grid (over standard fibre), single carrier modulation reaches its limits, unless severely reducing the optical reach.

- “Superchannel” approach:
  - Instead of modulating one optical carrier in the channel bandwidth, information is **shared over different subcarriers** located in this bandwidth;
  - They allow close packing and then a better SE;
  - Symbol rate is reduced which makes electronics easier.

Bitrate/ch	Subcarriers modulation and number		Distance (km)	SE (bit/s/Hz)	Year
1.3 Tbit/s	PDM QPSK	13	2400	2.9	2011
1.28 Tbit/s	PDM 64QAM	10	320	7.7	2012
1.28 Tbit/s	PDM 16QAM	4	2400	5	2012
1.12 Tbit/s	PDM 16QAM	7	400	5	2012
1 Tbit/s	PDM 16 QAM	4	400	5,7	2013
1 Tbit/s	PDM 32QAM	4	160	8	2015
1 Tbit/s	PDM 32 QAM	3	2000	6.7	2015

# Ultimate capacity of an optical fibre link.

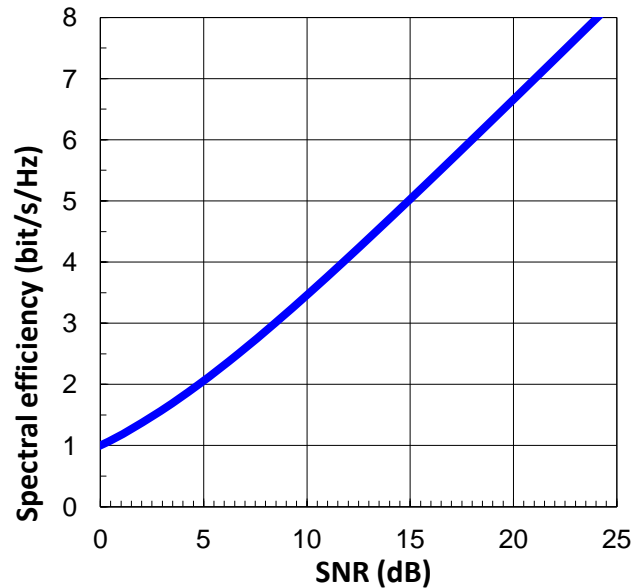

Shannon limit for the  
AWGN channel

## Capacity Estimates Results including Fiber Nonlinearity

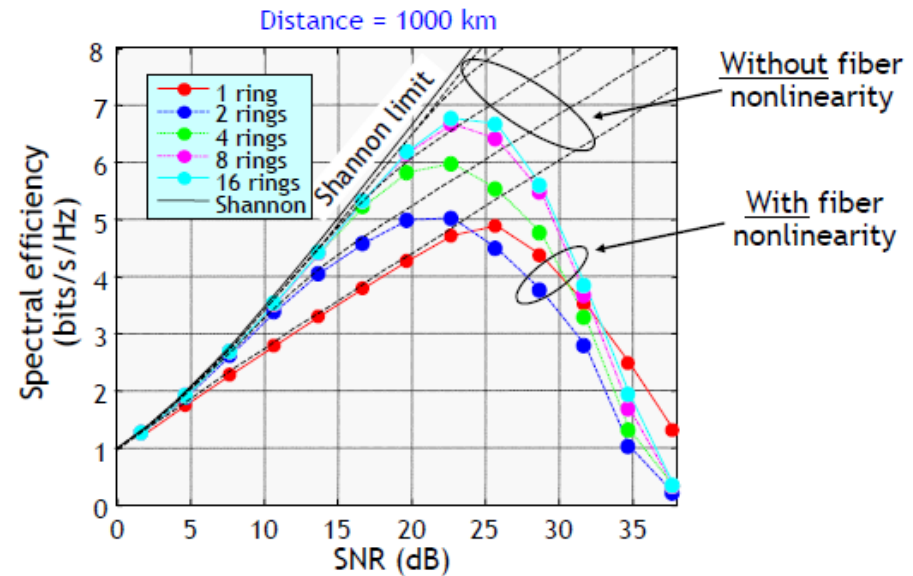

- With a sufficient number of rings, one can approach Shannon limit very closely
- Because of fiber nonlinearity, the capacity reaches a maximum at some SNR
- Maximum capacity can be increased by increasing the number of rings
- Increasing the number of rings beyond 16 brings marginal capacity increase

51 OFC Tutorial | March 2009

All Rights Reserved © Alcatel-Lucent 2009

Alcatel-Lucent 

From « *Capacity Limits of Fiber-Optic communication Systems* »  
R-J. Essiambre et al. OFC 2009 San Diego OThL1

# Non linear Shannon limit.

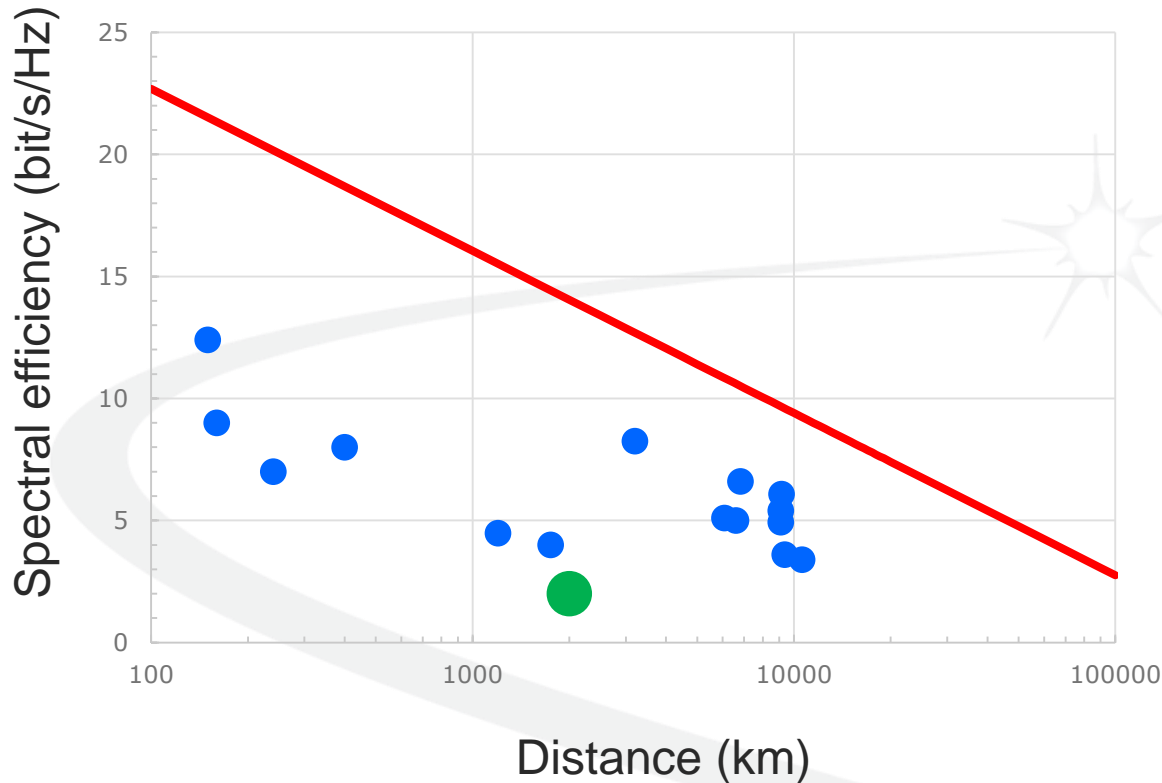

A better SE requires more power.  
But increasing power in order to increase OSNR is not possible without limit because of non-linear effects.

Then SE decreases when distance increases : this is the so called **NL Shannon limit**.

 100 Gbit/s PDM QPSK on a 50 GHz grid (2000 km 2 bit/s/Hz)

 Some recent experiments



- ✓ During twenty years, progress of WDM technology provided a continuously increasing capacity over an unchanged fibre infrastructure.
- ✓ We are approaching the end of this period.
- ✓ This is a major issue.

- Exploring new dimensions of multiplexing offers a possibility to avoid this “OSNR wall”;
- ✓ Multicore fibres: a fibre with  $M$  cores is equivalent to  $M$  fibres. Multicore fibres (MCF) and spatial division multiplexing (SDM);
- ✓ Within a multimode guide, the theoretically orthogonal modes are equivalent to parallel transmission lines. Few Multimode Fibres (FMF) and mode division multiplexing (MDM);
- ✓ Multicore and multimode approaches can be combined in the same fibre.

<http://www.fujikura.co.html>

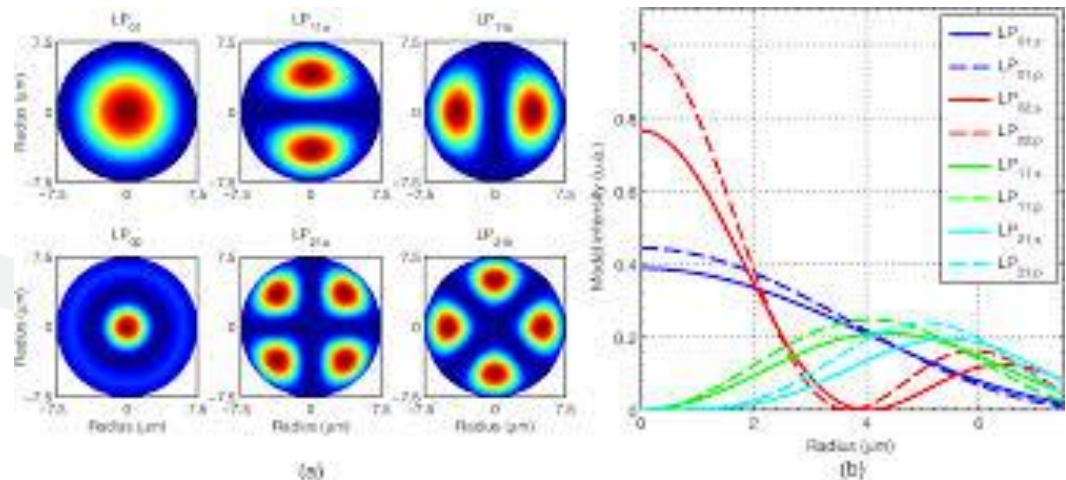
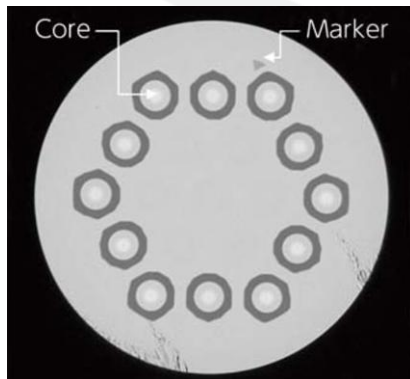

<http://opticalengineering.spiedigitallibrary.org/article.aspx?articleid=1901888>

- The main laboratories in the world have explored these topics since 2010;
- Very impressive results have been achieved;

Cores	Modes/c	WDM channels	Modulation	Distance (km)	SE (b/s/Hz)	Bitrate (Gbit/s)	Year
19	6	8	PDM QPSK	9.8	345	2900	2015
36	3	40	PDM QPSK	5.5	108	432	2015
22		399	PDM 64QAM	31	215.6	2150	2015
19	6	360	PDM QPSK	9.8	456	2050	2015
1	10	120	PDM QPSK	87	29	115.2	2015

# Evolution of capacity over 20 years

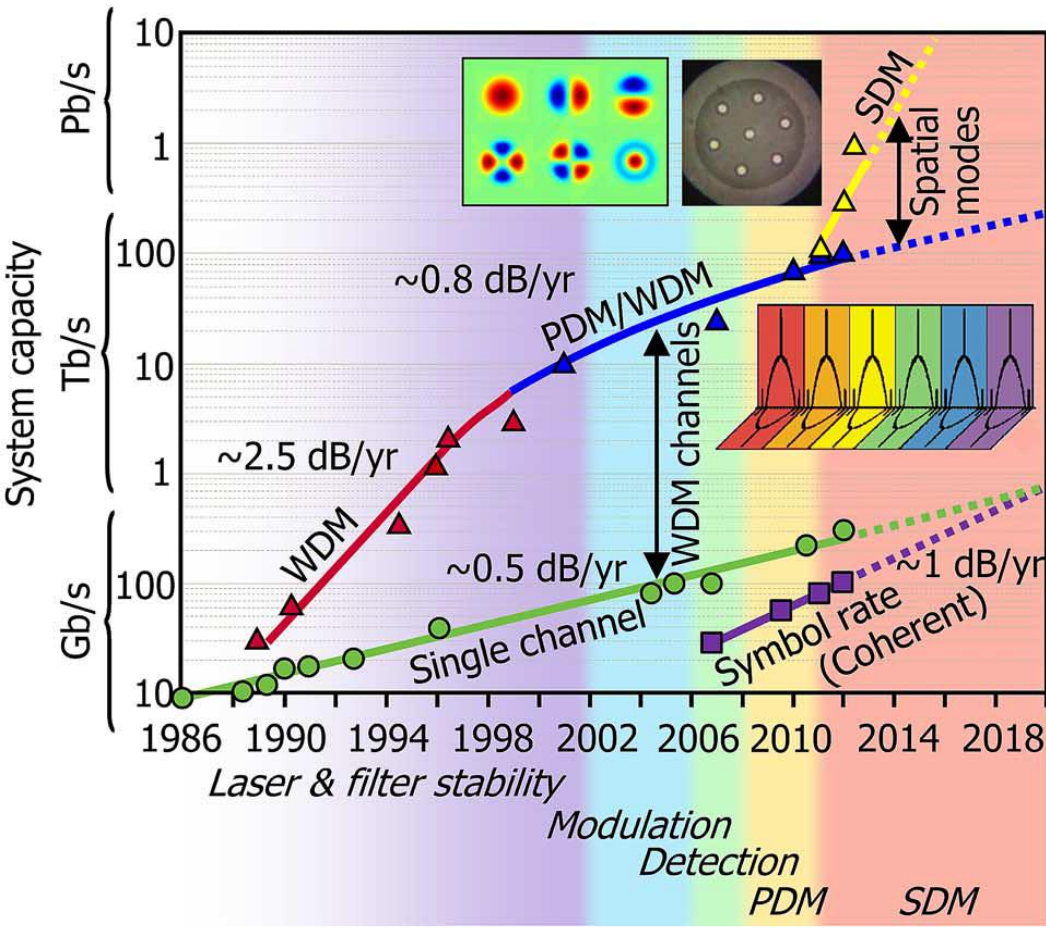

(a)

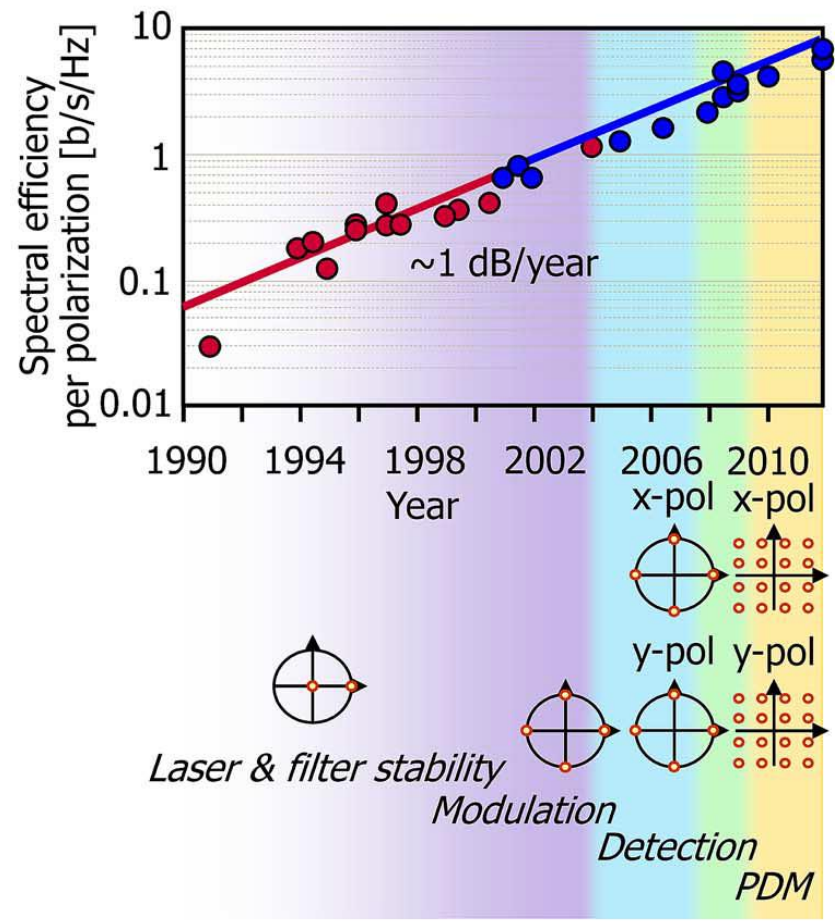

(b)

From *High Spectral Efficiency Optical Modulation Formats* P. Winzer  
 Journal of Lightwave Technology vol.30, n°24, pp 3824-3835