



HAL
open science

Ultra-high-throughput EMS NB-LDPC decoder with full-parallel node processing

Hassan Harb, Ali Al Ghouwayel, Laura Conde-Canencia, Cédric Marchand,
Emmanuel Boutillon

► **To cite this version:**

Hassan Harb, Ali Al Ghouwayel, Laura Conde-Canencia, Cédric Marchand, Emmanuel Boutillon. Ultra-high-throughput EMS NB-LDPC decoder with full-parallel node processing. 2020. hal-02494736v1

HAL Id: hal-02494736

<https://hal.science/hal-02494736v1>

Preprint submitted on 29 Feb 2020 (v1), last revised 10 Aug 2020 (v2)

HAL is a multi-disciplinary open access archive for the deposit and dissemination of scientific research documents, whether they are published or not. The documents may come from teaching and research institutions in France or abroad, or from public or private research centers.

L'archive ouverte pluridisciplinaire **HAL**, est destinée au dépôt et à la diffusion de documents scientifiques de niveau recherche, publiés ou non, émanant des établissements d'enseignement et de recherche français ou étrangers, des laboratoires publics ou privés.

Ultra-high-throughput EMS NB-LDPC decoder with full-parallel node processing

Hassan Harb, Ali Chamas Al Ghouwayel, Laura Conde-Canencia, Cédric Marchand and Emmanuel Boutillon

Abstract—This paper presents an ultra-high-throughput decoder architecture for NB-LDPC codes based on the Hybrid Extended Min-Sum algorithm. We introduce a new processing block that updates a check node and its associated variable nodes in a fully pipelined way, thus allowing the decoder to process one line of the parity check matrix per clock cycle. The work specifically focuses on a rate 5/6 code of size $(N,K) = (144, 120)$ symbols over GF(64). The synthesis results on 28-nm technology show that the proposed architecture improves the throughput efficiency of the state of the art by a factor greater than 10. The architecture reaches a throughput above 10 Gb/s for SNR values greater than 5 dB. Compared to a 5G binary LDPC code of same size and code rate, the proposed architecture offers a gain of 0.3 dB at a Frame Error Rate of 10^{-3} . The proposed architecture reduces the required memory bandwidth by almost 50 % compared to a classical LDPC code. We also provide a detailed comparison with competitive state-of-the-art NB-LDPC decoder implementations in terms of performance, surface and decoding throughput are given.

Index Terms—Channel coding, decoder implementation, ASIC, non-binary LDPC, Min-Sum, parity check.

I. INTRODUCTION

NON-Binary (NB) Low-Density Parity-Check (LDPC) codes allow to close the performance gap with the Shannon limit [1] when using small or moderate frame lengths. They are defined on high order Galois Fields (GF) of order q with $q > 2$ and have been proven to be more robust than convolutional turbo-codes and binary LDPC codes [2]. However, even if they present numerous advantages (see [3] [4]) their main drawback is complexity, which is challenging at the receiver side. In NB-LDPC decoders, the direct application of the Belief Propagation (BP) [5] algorithm leads to $O(q^2)$ complexity and is thus prohibitive for $q > 16$. A considerable amount of work has then been dedicated to reduce the complexity of decoding algorithms and their associated architectures ([6] [7] [8], among others), with a special focus on the Check Node (CN) processing which is the major bottleneck in NB-LDPC decoders.

This work particularly focuses on the Extended Min-Sum (EMS) algorithm [9] [10] as it currently continues to present one of the most competitive complexity/performance trade-offs [11] [12]. For the EMS CN implementation, the Forward-Backward (FB) approach was introduced in [12] as a serial concatenation of Elementary CNs (ECNs). This structure suffers from high latency and low decoding throughput. Other approaches were proposed (e.g., the Trellis-EMS (T-EMS) [13]) to reduce latency. However, the T-EMS presents a complexity that increases with q when parallel implementation is considered. This complexity was reduced with the one-

minimum T-EMS [14] and the Trellis Min-Max (T-MM) [15] [16] algorithms.

In this paper we show how some innovative ideas have significantly enhanced prior designs [4] [17]. This prior work includes the Syndrome-based algorithm [18] that efficiently performed parallel CN computations for $q \geq 16$ and was initially considered for implementing a GF(256) CN processor with a CN degree $d_c = 4$ [19]. However, its complexity is dominated by the number of computed syndromes which increases quadratically with d_c . This limits its interest for high coding rates (i.e., high d_c values). A solution was then proposed based on sorting the input vectors according to a reliability criteria [20] [21] to significantly reduce the CN hardware complexity without affecting performance. This so-called *presorting* technique was applied to the syndrome-based architecture in [20] and to the FB architecture in [21]. A hybridization of those two architectures was presented in [17] for high q and d_c values.

In this paper we consider the work in [17] to design a pipelined decoder that significantly outperforms the state of the art in terms of throughput and efficiency. The design includes the presorting technique and an innovative unit that processes both the CNs and Variable Nodes (VN). For the practical description of the decoder we consider a specific code but the new proposed principles can be easily generalized to any NB-LDPC code, knowing that its benefits are specially interesting for high rates. We synthesized the decoder on 28-nm technology and performed a detailed study of its throughput and efficiency for comparison with the state of the art. Our design reaches a decoding throughput above 10 Gbit/s for a CN degree of order 12, which represents a significant gain compared to [17]. In terms of throughput efficiency (i.e., throughput per gate ratio), the gain factor is in the order of 6 (for low SNR values) and up to 100 (for high SNR values). This improvement in terms of throughput efficiency is also helped by the processing of two frames concurrently at the cost of the duplication of the memory banks.

The paper is organized as follows: Section II introduces notation, NB-LDPC codes, the principles of the EMS algorithm and the structure of the code considered in this work. Section III recalls the presorting technique and describes the decoding steps and the CN-VN merging technique. Section IV is dedicated to the global decoder architecture. Simulation results for the proposed code and its binary LDPC counterpart are compared in Section V. Implementation results, throughput analysis and a detailed comparison with the state of the art are presented in section VI. Finally, conclusions and perspectives are discussed in Section VII.

II. NOTATION, NB-LDPC CODES AND EMS ALGORITHM

This Section introduces NB-LDPC codes, describes the calculation of the intrinsic messages and the principles of the EMS algorithm. Table I lists the symbols and acronyms considered throughout the paper, which include the characteristics of the code, the exchanged messages in the decoder and other terms for the description of the global decoder.

A. NB-LDPC codes defined over Galois Fields

A NB-LDPC code is a linear block code defined on a very sparse parity-check matrix H whose non-zero elements belong to a finite field $\text{GF}(q)$, where $q > 2$. The elements of $\text{GF}(q)$ are $\{0, \alpha^0, \alpha^1, \dots, \alpha^{q-2}\}$. The dimension of matrix H is $M \times N$, where M is the number of parity-CNs and N is the number of VNs (i.e., the number of $\text{GF}(q)$ symbols in a codeword). A codeword is denoted by $\mathbf{C} = (x_0, x_1, \dots, x_{N-1})$, where x_k , $k = 0, \dots, N-1$, is a $\text{GF}(q)$ symbol represented by $m = \log_2(q)$ bits as $x_k = (x_{k,0} \ x_{k,1} \ \dots \ x_{k,m-1})$. The construction of regular (d_v, d_c) NB-LDPC codes is expressed as a set of M parity-check equations C_j , $j = 0, 1, \dots, M-1$, over $\text{GF}(q)$, where the j^{th} parity check equation C_j is given as

$$C_j : \sum_{i=0}^{d_c-1} h_{j,k(j,i)} x_{k(j,i)} = 0, \quad (1)$$

where $\{k(j,i)\}_{i=0,1,\dots,d_c-1}$ is the set of the d_c non-null positions in the j^{th} row of the matrix H and $h_{j,k(j,i)}$ its associated GF values. Each variable is connected to exactly d_v non-null elements in a column.

B. Intrinsic messages

The exchanged messages in the EMS decoding algorithm are Log Likelihood Ratio (LLR) values. The intrinsic LLR values are computed from an observed information coming from the channel. If we consider the Additive White Gaussian Noise (AWGN) channel and a Binary Phase-Shift Keying (BPSK) modulation, the GF symbol x will be modulated by m BPSK channels with amplitude $\mathbf{B}(x_p) = (-1)^{x_p}$, $p = 0, \dots, m-1$. At the receiver side, the received samples r_p are expressed as:

$$r_p = \mathbf{B}(x_p) + w_p,$$

where w_p is a realization of a Gaussian noise of variance σ^2 .

Let $Y = (y_0, y_1, \dots, y_{m-1})$ be the LLR intrinsic vector associated to x . Each value y_p is defined as:

$$y_p = \log \left(\frac{\mathbf{P}(x_p = 0/r_p)}{\mathbf{P}(x_p = 1/r_p)} \right) = \frac{2r_p}{\sigma^2}. \quad (2)$$

Let $\bar{x} = (\bar{x}_0, \bar{x}_1, \dots, \bar{x}_{m-1})$, where the values \bar{x}_p are defined as hard decisions such that if $\text{sign}(y_p) > 0$, then $\bar{x}_p = 0$, $\bar{x}_p = 1$ otherwise. Considering the hypothesis that all the symbols in the $\text{GF}(q)$ alphabet have equal probability, the expression of the LLR $I^+(x)$ of a symbol x knowing y is expressed as:

$$I^+(x) = \sum_{p=0}^{m-1} |y_p| \Delta(x_p, \bar{x}_p), \quad (3)$$

TABLE I
NOTATION

| Symbols | |
|---|---|
| q | Order of GF |
| $m = \log_2(q)$ | Number of bits per GF(q) symbol |
| \mathcal{H}, H | Prototype matrix and Parity-Check Matrix (PCM) |
| (M, N) | Number of rows (CNs) and columns (or VNs) in H |
| $K = N - M$ | Number of information symbols |
| d_c | Degree of connectivity of the CN (number of VNs connected to a CN) |
| d_v | Degree of connectivity of the VN (number of CNs connected to a VN) |
| h | non-zero GF elements in H |
| $h_{j,k}$ | non-zero element in H that connects j^{th} CN with k^{th} VN |
| $\{0, \alpha^0, \dots, \alpha^{q-2}\}$ | GF(q) elements |
| x | a GF symbol |
| $Y = (y_0, y_1, \dots, y_{m-1})$ | m bit LLR values associated to a symbol |
| $\Pi = \{\pi(0), \pi(1), \pi(2)\}$ | Indexes of the 3 smallest magnitudes of y |
| X^+ | LLR value of X |
| X^\oplus | GF value of X |
| $n_{m_{in}}$ | Number of CN input messages |
| $n_{m_{out}}$ | Number of CN output messages |
| $I = \{I[0], \dots, I[n_{m_{in}} - 1]\}$ | Intrinsic vector of size $n_{m_{in}}$ |
| $I[j] = (I^+[j], I^\oplus[j])$ | j^{th} element of I composed of a couple ($I^+[j]$ = LLR value, $I^\oplus[j]$ = GF value) |
| $U = \{U[0], \dots, U[n_{m_{in}} - 1]\}$ | CN input vector |
| $U' = \{U'[0], \dots, U'[n_{m_{in}} - 1]\}$ | Switched CN input vector after presorting |
| $V = \{V[0], \dots, V[n_{m_{out}} - 1]\}$ | CN output vector |
| \hat{x} | Decision on VN V |
| $n_{max,it}$ | Maximum number of iterations |
| $n_{av,it}$ | Average number of iterations |
| $\Psi = \{\psi_0, \dots, \psi_{d_c-1}\}$ | Indexes generated by the presorting |
| b | Number of bits of quantization |
| Acronyms | |
| GF | Galois Field |
| PCM | Parity-Check Matrix |
| AWGN | Additive White Gaussian Noise |
| BPSK | Binary Phase-Shift Keying |
| LLR | Log Likelihood Ratio |
| CN | Check Node |
| VN | Variable Node |
| SN | Syndrome Node |
| VSV | Valid Syndrome Vector |
| DB | Decorrelation Block |
| CU | Control Unit |
| DMU | Decision Making Unit |
| DMR | Decision Making Reorder |
| GFRB | GF Router Block |
| SCRB | Stopping Criteria Router Block |
| PTB | Parity Test Block |
| FPHD | Full Parallel Hybrid CN Decoder |
| RAM | Random Access Memory |

where $\Delta(x_p, \bar{x}_p) = 0$ if $x_p = \bar{x}_p$ and $\Delta(x_p, \bar{x}_p) = 1$ otherwise. Note that, by definition, $I^+(\bar{x}) = 0$ is the smallest LLR value. It will be denoted as $I[0] = (I^+[0], I^\oplus[0])$, with the LLR $I^+[0] = I^+(\bar{x}) = 0$ and the associated GF value $I^\oplus[0] = \bar{x}$. Let $\Pi = \{\pi(0), \pi(1), \pi(2)\}$ be respectively the index of the smallest, the second smallest and the

third smallest magnitude $|y_p|$ values, $p = 0, 1, \dots, m-1$. Then, the second smallest LLR value $I^+[1]$ is obtained by flipping the bit of \bar{x} of index $\pi(0)$ to obtain $I^\oplus[1]$, i.e., $I[1] = (I^+[1] = |y_{\pi(0)}|, I^\oplus[1])$. The third smallest value $I^+[2]$ is obtained by flipping the bit of \bar{x} of index $\pi(1)$ to obtain $I^\oplus[2]$. Thus, $I[2] = (I^+[2] = |y_{\pi(1)}|, I^\oplus[2])$. Finally, the fourth smallest LLR value $I^+[3]$ is given by $\min(A, B)$ with $A = |y_{\pi(0)}| + |y_{\pi(1)}|$ and $B = |y_{\pi(2)}|$. If $\min(A, B) = A$, the associated GF values $I^\oplus[3]$ is obtained by flipping the bits of index $\pi(0)$ and $\pi(1)$ of \bar{x} , otherwise, if $\min(A, B) = B$, $I^\oplus[3]$ is obtained by flipping the bit of index $\pi(2)$ of \bar{x} . This method and its generalization to compute in parallel the first $n_{m_{in}}$ terms of the intrinsic vector I are described in details in [22]. Finally, for hardware design, the LLR values need to be quantized on a fixed precision. To do so, we use the following expression

$$y_p = \text{sat}(\lfloor \gamma r_p Q + 0.5 \rfloor, Q),$$

where $\text{sat}(x, Q)$ is the clipping function of x in $[-Q, Q]$ ($\text{sat}(x, Q) = x$ if $|x| < Q$, $\text{sign}(x) \times Q$ otherwise), $\lfloor x \rfloor$ indicates the floor function, $Q = 2^{b-1} - 1$ is the saturation value expressed as a function of b , the number of bits of quantization (for $b = 6$, $Q = 31$). The fix scaling factor γ encompasses the scaling factor $2/\sigma^2$ found in the LLR expression of (2). The γ value is set empirically to $\gamma = 1.2$ in order to optimize the decoding performance.

C. Extended Min-Sum algorithm for NB-LDPC codes

A detailed description of the different steps and equations in the Min-Sum (MS) algorithm was presented in [4]. We consider in this paper the Extended Min-Sum (EMS) [11] with the following characteristics: VN degree $d_v = 2$, CN input messages truncated to a size $n_{m_{in}} \ll q$ and CN output messages to $n_{m_{out}} \ll q$. This leads to computation and storage reduction without necessarily performance loss [9] [10].

For the EMS algorithm description, we define the following:

- $I = \{I[0], \dots, I[n_{m_{in}} - 1]\}$ as an intrinsic LLR vector (see previous section),
- $\{h_0, \dots, h_{d_c-1}\}$ are the d_c non-zero elements in H associated to a CN,
- $\{U_0, \dots, U_{d_c-1}\}$: group of messages sent to a CN from the d_c connected VNs,
- $\{V_0, \dots, V_{d_c-1}\}$: group of messages sent to d_c VNs from a CN.

Each U_i message can be written as $U_i = \{U_i[0], \dots, U_i[n_{m_{in}} - 1]\}$. Each element $U_i[j]$ corresponds to a couple $U_i[j] = (U_i^+[j], U_i^\oplus[j])$ where $U_i^\oplus[j]$ is the GF(q) symbol and $U_i^+[j]$ its corresponding LLR value, $i = 0, \dots, d_c - 1$ and $j = 0, \dots, n_{m_{in}} - 1$. The elements in these messages are sorted related to their LLR values. The four steps of the EMS algorithm considering $d_v = 2$ are:

1) *LLR calculation*: The LLR calculation is defined in section II.B. It generates the intrinsic vector I of size $n_{m_{in}} = 4$.

2) *CN update*: The CN update is processed as

$$V_i^+(x) = \min \left\{ \sum_{i'=0, i' \neq i}^{d_c-1} U_{i'}^+[j_{i'}] \oplus_{i'=0, i' \neq i}^{d_c-1} U_{i'}^\oplus[j_{i'}] = x \right\}, \quad (4)$$

where $j_{i'} \in \{0, 1, \dots, n_{m_{in}} - 1\}$ for $i' = 0, 1, \dots, d_c - 1$, $i' \neq i$ and \oplus refers to GF addition (i.e., XOR gate).

The final stage is to partially sort in increasing order the set of values of $V_i^+(x)$ indexed by $x \in \text{GF}(q)$ to obtain an ordered set $V_i^\oplus = \{x_0, x_1, \dots, x_{n_{m_{out}}-1}\}$ that verifies

$$\forall(j, k), j < k < n_{m_{out}} \Rightarrow V_i^+(x_j) \leq V_i^+(x_k),$$

and

$$\forall x \in \text{GF}(q), x \notin V_i^\oplus \Rightarrow V_i^+(x_{n_{m_{out}}-1}) \leq V_i^+(x).$$

The i^{th} output message is thus given as $V_i = \{V_i[0], V_i[1], \dots, V_i[n_{m_{out}}-1]\}$, where $V_i[j] = (V_i^+[j] = V_i^+(x_j), V_i^\oplus[j] = x_j)$, $j = 0, 1, \dots, n_{m_{out}}-1$.

In the state of the art, the GF values outside V_i are associated with a default LLR value D_i , with $D_i = V_i^+[n_{m_{out}} - 1] + O$, i.e., the default value is equal to the highest LLR value of the V message added with O , a positive offset value (see [10] for more details on the definition of the offset value). In section III.A, we propose a new method to determine the default value D_i to facilitate the hardware implementation of the full parallel CN architecture.

3) *VN update*: After processing CN a , the required inputs of a VN are: the intrinsic vector I of size $n_{m_{in}}$, the m values of Y to be able to compute $I^+(x)$ for any $x \in \text{GF}(q)$ using (3), the received message V^a of size $n_{m_{out}}$ coming from CN a , the default value D^a associated to message V^a and the message U^a sent to the CN a (U^a encompasses both I information and the updated message V^b coming from CN b). Note that U^a is used only for the decision process). The two outputs of the VN are the current message U^b of size $n_{m_{in}}$ to be sent to CN b and the VN decision \hat{x} obtained by combining V^a and U^a .

The first step of the VN processing is the addition of the intrinsic LLR values on the incoming V^a message to generate the message \bar{V}^a defined as:

$$\bar{V}^{a,+}[j] = V^{a,+}[j] + I^+(V^{a,\oplus}[j]), \quad j = 0, 1, \dots, n_{m_{out}} - 1. \quad (5)$$

Since \bar{V}^a associates LLR values for only a subset of GF values, in parallel, a second message \bar{I} is generated as

$$\bar{I}^+[j] = I^+[j] + D^{a,+}, \quad j = 0, 1, \dots, n_{m_{in}} - 1. \quad (6)$$

Then, the $n_{m_{in}}$ smallest values of set $\bar{V}^a \cup \bar{I}$ in terms of LLR value are extracted along with their associated GF symbols to generate the vector messages \bar{U}^b . Note that by construction, $\bar{V}^{a,\oplus} \cap \bar{I}^\oplus$ may not be empty. In that case, the corresponding LLR element in \bar{I} is saturated so that \bar{U}^b contains the first $n_{m_{in}}$ smallest LLR values with distinct GF values. The last step to generate the final message is the normalization process that keeps the first LLR of the message equal to zero, i.e.,

$$U^{b,+}[j] = \bar{U}^{b,+}[j] - \bar{U}^{b,+}[0],$$

$$U^{b,\oplus}[j] = \bar{U}^{b,\oplus}[j], \quad j = 0, \dots, n_{m_{out}} - 1. \quad (7)$$

4) *Decision making*: in the MS algorithm, the decision is done by adding all the incoming information, i.e.,

$$\hat{x} = \arg \min_{x \in \text{GF}(q)} (V^{a,+}(x) + V^{b,+}(x) + I^+(x)). \quad (8)$$

In the EMS algorithm [4], this process is simplified first by considering that U^a already contains the summation $V^b + I$, then by pruning the n_{min} elements of vector U^a to its first 3 elements. The merging of the n_{out} elements of V^a and the first three elements of U^a gives V^T as $V^T[j] = (V^{T,+}[j], V^{T,\oplus}[j] = U^{a,\oplus}[j])$, $j = 0, 1, \dots, n_{out} - 1$, where

$$V^{T,+}[j] = V^{a,+}[j] + \begin{cases} U^{a,+}[0] & \text{if } V^{a,\oplus}[j] = U^{a,\oplus}[0] \\ U^{a,+}[1] & \text{if } V^{a,\oplus}[j] = U^{a,\oplus}[1] \\ U^{a,+}[2] + O & \text{otherwise.} \end{cases} \quad (9)$$

Note that $U^{a,+}[0] = 0$ and that, compared to [4], the new version omits the case where $V^{a,\oplus}[j] = U^{a,\oplus}[2]$.

Finally, the decision is made $\hat{x} = V^{T,\oplus}[k]$ with $k = \arg \min_j \{V^{T,+}[j]\}$. In practice, the offset value O is equal to 1.

Before describing the flooding algorithm, we present the NB-LDPC code implemented in the paper.

D. Code Structure

The code considered in this work is a $(N, K) = (144, 120)$ NB-LDPC defined over $\text{GF}(64)$ with $d_v = 2$, $d_c = 12$ and code rate $r = 5/6$. This code is a Quasi-Cyclic LDPC code constructed from the complete 2×12 base matrix \mathcal{H} defined as

$$\mathcal{H} = \begin{bmatrix} 0 & 0 & 0 & 0 & 0 & 0 & 0 & 0 & 0 & 0 & 0 & 0 \\ 0 & 1 & 2 & 3 & 4 & 5 & 6 & 7 & 8 & 9 & 10 & 11 \end{bmatrix} \quad (10)$$

with an expansion factor of 12. During the lifting process of \mathcal{H} , every element $\mathcal{H}(i, j)$, $i = 0, 1$ and $j = 0, 1, \dots, 11$, is replaced by the 12×12 identity matrix with a right shift rotation equal to $\mathcal{H}(i, j)$. Based on this definition, the resulting matrix H is of size $(M, N) = (24, 144)$ in $\text{GF}(64)$. The equivalent size in binary is thus $(M, N) = (864, 720)$.

Let us define layer one (L_1) as the set of CNs of index 0 to 11 and layer two (L_2) as the set of CNs of index 12 to 23. Then, any variable is connected to a unique CN in L_1 and a unique CN in L_2 . According to the parity check equation given in (1), the 12 indexes $k(j, i)$ of the j^{th} parity check are given by $k(j, i) = j + 12i$ when $j = 0, 1, \dots, 11$ and $k(j, i) = \text{mod}(j + i, 12) + 12i$ when $j = 12, 13, \dots, 23$.

The GF coefficients $\{h_{j,k(j,i)}\}_{i=0,1,\dots,11}$ of the first layer L_1 and second layer L_2 are $\alpha^{\{43,0,31,4,37,9,59,14,49,20,55,25\}}$ and $\alpha^{\{0,31,4,37,9,59,14,49,20,55,25,43\}}$, respectively.

E. Flooding scheduling

The decoding process iterates until a maximum number of iterations ($n_{max,it}$) is reached or the M parity equations are satisfied. In each iteration, M CN and $M \times d_c$ VN updates are performed. At the end of every iteration, a decision is taken on the N VNs.

Let $l = 0, \dots, n_{max,it} - 1$ be the iteration number. In the following, every vector message that is being processed at iteration l is appended by (l) at its exponent. The decoding process is described in Algorithm 1.

Input: Received message composed of $N = 144$ received GF symbols $Y_k = \{y_{k,0}, y_{k,1}, \dots, y_{k,5}\}$, $k = 0, 1, \dots, 143$.

Output: Decoded message $\hat{C} = \{\hat{x}_0, \dots, \hat{x}_{N-1}\}$.

Notations $U_k^{(l),u}$ refers to the message sent at iteration l from the VN k to the CN of layer u , $u = 0, 1$.

Initialization:

$l = 0$; decoded = false.

for $k \leftarrow 0$ **to** 143

 Compute $I_k = (I_k[i])_{i=0,1,2,3}$, and Π_i (section II-B).

$U_k^{(0),0} = U_k^{(0),1} = I_k$

end for

Iterative decoding:

while $l < n_{max,it}$ **and** not(decoded)

$l = l + 1$;

for $j \leftarrow 0$ **to** 11 (processing of layer L_1)

 Parallel computation with $i = 0, 1, \dots, 11$

$\{U_{k(j,i)}^{(l-1),0}\} \xrightarrow{\text{see II.C.2}} \{V_{k(j,i)}^{(l),0}\}$

$(\{V_{k(j,i)}^{(l),0}\}, I_{k(j,i)}, |Y_{k(j,i)}|, \Pi_{k(j,i)}) \xrightarrow{\text{see II.C.3}} \{U_{k(j,i)}^{(l),1}\}$

$(\{U_{k(j,i)}^{(l),0}\}, \{V_{k(j,i)}^{(l),0}\}, I_{k(j,i)}, |Y_{k(j,i)}|, \Pi_{k(j,i)}) \xrightarrow{\text{see II.C.4}} \hat{x}_{k(j,i)}$

end for

for $j \leftarrow 12$ **to** 23 (processing of layer L_2)

 Parallel computation with $i = 0, 1, \dots, 11$

$\{U_{k(j,i)}^{(l-1),1}\} \xrightarrow{\text{see III.A}} \{V_{k(j,i)}^{(l),1}\}$

$(\{V_{k(j,i)}^{(l),1}\}, I_{k(j,i)}, |Y_{k(j,i)}|, \Pi_{k(j,i)}) \xrightarrow{\text{see III.B}} \{U_{k(j,i)}^{(l),0}\}$

end for

 decoded = true; (is \hat{x} a codeword?)

for $j \leftarrow 0$ **to** 23

if Parity check C_j (see equation (1)) not satisfied with \hat{x} .

 decoded = false

end if

end for

end while

Algorithm 1: Flooding scheduling of matrix H .

III. PIPELINED CN-VN UNIT

This section presents a pipelined architecture able to perform a CN of degree $d_c = 12$ and its 12 associated VNs every clock cycle. To do this parallel architecture, we first remind the principle of the hybrid CN architecture [17]. Then, based on this formalism, we describe the result of the optimization process of the CN architecture for the 5/6-rate $N = 144$ code in the paper. Then, an innovative method to merge VN and CN processing is presented.

A. Principle of the hybrid CN architecture

In [17], the authors present the principle of the hybrid CN architecture. The three main functions performed by this CN are recalled: the presorting, the ECN processing and the decorrelation using the Valid Syndrome Vector (VSV).

1) *Presorting*: The preliminary step of CN processing is the presorting block that leads to a significant reduction of the CN computations. In [21] the authors proposed the sorting of the CN input vectors based on the LLR value of the second GF element. This sorting polarizes the reliability of the input vectors and classifies them into two sets: high reliability and low reliability. As described in Section II-B, the first element (i.e., the most reliable symbol) has a zero LLR value, while the second has the first non-zero LLR value. The sorting criteria is the following: the higher the LLR value of the second element, the higher the reliability of the vector. In other terms, a *big* difference between the first and second LLR values indicates that the competition between the GF symbols in the vector will clearly favor the first one and the rest will *rarely* contribute to the final decision on the codeword. Discarding (or eliminating) them leads to computational reduction without any performance loss. As a consequence, presorting *helps* the CN to concentrate its processing effort on low-reliability vector messages.

Fig. 1 shows the presorting principle for $d_c = 4$, $n_{min} = 4$ and GF(64). The second most reliable LLR values $\{2, 5, 1, 3\}$ of each message (U_0 to U_3) are considered as inputs to a sorter block. Then, the d_c input messages are switched based on the indexes ψ . The high reliability messages are concentrated in one region and dashed elements are discarded prior to the CN processing. More details on the presorting technique are presented in [20], [21] and [23].

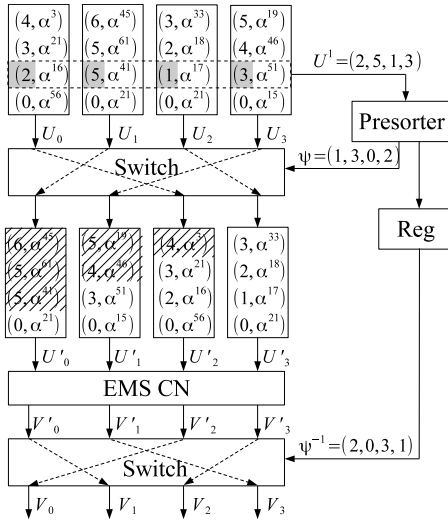

Fig. 1. Presorting principle of the EMS-based CN.

2) *ECN*: For the implementation of the CN processing, equation (4) is implemented in a simplified way using the hybrid CN architecture defined in [17]. The whole CN architecture is characterized graphically in Fig. 2.a). Let us describe, from top to bottom, the graphical elements used in this design and the corresponding processing.

First, the number of elements of U'_i , $i = 0, \dots, 11$, that enter the CN is indicated by the number of circles below it. For example, only $U'_0[0] = (U_0^+[0], U_0^\oplus[0])$ enters the CN while only the first 3 elements $\{U'_8[1], U'_8[2], U'_8[3]\}$ out of $n_{min} = 4$ elements of message U'_8 enter the CN. The line of multipliers

on the top indicates that each GF values of U'_k are multiplied by the GF coefficient h'_k . The outputs of the multipliers enter a rather dense datapath composed of a network of ECN. Each ECN performs the bubble check algorithm. Let us give the key to understand the processing performed by the generic ECN given in Fig. 2.b). An ECN receives two input vectors A and B of size n_a and n_b given by the number of circles (or bubbles) respectively in the first column and in the first row ($n_a = 4$ and $n_b = 3$ in Fig. 2.b)). It generates an output message C of size n_c . Note that in Fig.2.a), the output size is implicitly defined as the number of inputs (i.e., number of vertical bubbles) of the next ECN. A circle in position (t_0, t_1) , $t_0 = 0, \dots, n_a - 1$ and $t_1 = 0, \dots, n_b - 1$, means that $U_a[t_0]$ and $U_b[t_1]$ are added to generate a couple $(U_a^+[t_0] + U_b^+[t_1], U_a^\oplus[t_0] \oplus U_b^\oplus[t_1])$. The n_c bubbles of minimum LLR sorted in increasing order constitute the output vector of the ECN. The VSV is appended with a boolean value that indicates whether $U_c[t_2]$, $t_2 = 0, \dots, n_c - 1$, has been generated with $U_b[0]$ or with $U_b[t_1]$, $t_1 > 0$. Bubbles in dark color append a false Boolean value to the corresponding position in the VSV vector. The three last ECNs (ECN11, ECN12 and ECN13) are slightly simplified compared to the other ECNs because all the bubbles are output without any sorting. In fact, one of the main ideas in the architecture is to save hardware complexity by postponing the sorting operation in the VN processing. Since no sorting is performed, the default value D of the check to variable message cannot be determined. Thus, we propose to empirically set it to the LLR of a fixed bubble position indicated by D_g , D_{10} and D_{11} in ECN11, ECN12 and ECN13, respectively. Note that the size of the output message S of ECN11 is $n_S = 20$ while the size of the message of ECN12 and ECN13 is $n_{FB} = 16$. Any element of S is given by the summation of all the incoming messages, a decorrelation process is thus required [17]. It suppresses the GF symbol $U_i^\oplus[0]$ from $S^\oplus[t]$ if $U_i^\oplus[0]$ contributes in computing $S^\oplus[t]$ to generate the i^{th} output thanks to the GF adder (addition and subtraction are equivalent in the GF domain), where $i = 0, \dots, 11$, $t = 0, \dots, n - 1$ and $n \in \{n_S, n_{FB}\}$. Otherwise, if $U_i^\oplus[0]$ does not contribute in computing $S^\oplus[t]$, the Decorrelation Block (DB) associated to U'_i saturates the LLR value $S^+[t]$. This is done thanks to the VSV vector that is being checked by the DB. The final multiplication is applied on the GF value to compute the output message V'_i . In more details, $V'_i^\oplus[t] = (S^\oplus[t] - U_i^\oplus[0]) \cdot h_i'^{-1}$ and $V_i'^+[j] = S^+[t]$.

B. CN-VN Processing

Fig. 3 shows the architecture of the proposed parallel pipelined CN-VN. Every input E_i , $i = 0, \dots, d_c - 1$, carries U_i^a and the information associated to it, i.e., $E_i = \{U_i^a, h_i, h_i^{-1}, |Y_i|, \Pi_i, I_i^\oplus\}$. Let $\mathbf{E} = \{E_0, \dots, E_{11}\}$, the first stage of the proposed joint CN-VN unit starts in a similar way than the hybrid architecture, except that all messages are received in parallel: first, the message \mathbf{E} is permuted using the indexes Ψ obtained by the presorting block, then the hybrid CN is performed. The presorting receives $\{U_0^+[1], \dots, U_{11}^+[1]\}$ to generate the indexes $\Psi = \{\psi[0], \dots, \psi[11]\}$ for $d_c = 12$

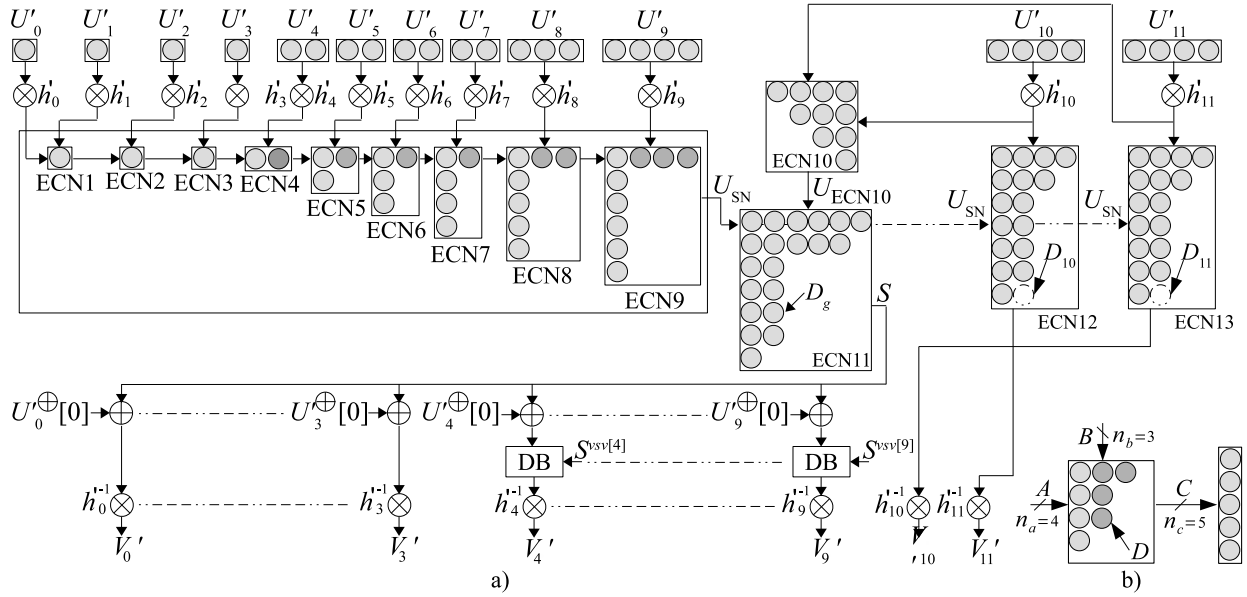

Fig. 2. a) High level CN architecture and b) ECN in case of $n_a = 4$, $n_b = 3$ and $n_c = 5$.

based on the presorting principle shown in Fig. 1, thus $U_{\psi[0]}^+ [1] \leq U_{\psi[1]}^+ [1] \leq \dots \leq U_{\psi[11]}^+ [1]$. The architecture of the parallel pipelined presorting architecture is shown in Fig. 4. This architecture is inspired from [24]. Every comparator-swap receives two inputs where the one that is having minimum LLR value will be positioned at the lower output and the one with maximum LLR value will be positioned at the higher output. The indexes of the inputs are also shifted. It consists of 42 comparator swap components configured such that at the output every $\psi[i]$, $i = 0, \dots, d_c - 1$, is having only the index of the $(i + 1)^{th}$ minimum value. Based on the Ψ values, the inputs $\{E_0, \dots, E_{11}\}$ of the CN-VN are switched using the permutation block. Every $\psi[i]$ is coded on 4 bits since there are $d_c = 12$ positions. Thus, the size of Ψ is $4 \times 12 = 48$ bits. Once the input message permuted, the CN is performed. The specification of the CN was defined in section III.A.

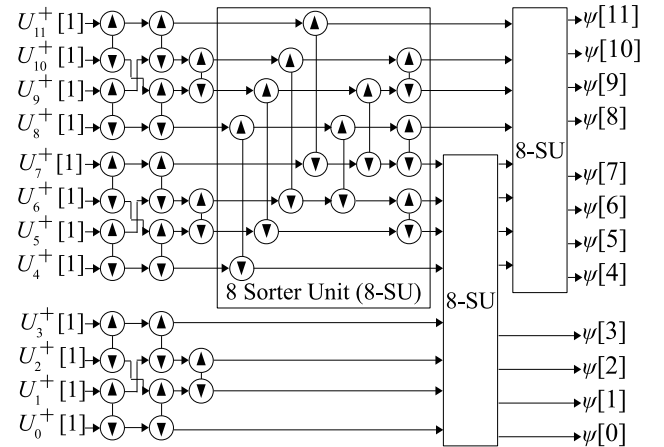

Fig. 4. Presorting architecture.

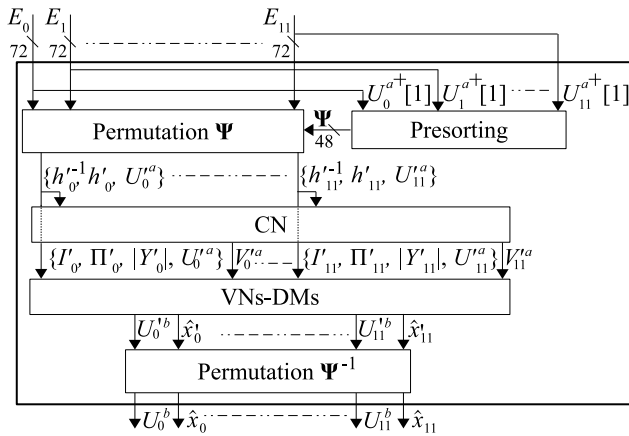

Fig. 3. CN-VN architecture.

After the CN processing, the VNs-DMs block operates to make the VN update and the decision on every input. There

are 12 VN and 12 DM blocks associated to a CN. The VN and DM processing were described in section II.C. Note that the size of input vector V^a can take two values, i.e., $n_{FB} = 16$ for $\{V_{10}^a, V_{11}^a\}$ and $n_s = 20$ for $\{V_0^a, \dots, V_9^a\}$. The size of the output vector U^b is always $n_{min} = 4$. Since the vector $\{V_0^a, \dots, V_{11}^a\}$ is not reordered before the VN processor, all the information required for the VN processor should also follow the permutation Ψ in order to be consistently processed. Thus, for each input vector, the information associated to the i^{th} message U_i^a , i.e., $(I_i^\oplus[0], |Y_i|, \Pi_i)$, $i = 0, \dots, d_c - 1$, are also permuted thanks to the permutation Ψ . It represents a total of $(6 + 5 \times 6 + 3 \times 4) = 54$ bits. The generation of U_i^a and decision \hat{x}_i^t follows the work described in [17], except that all the operations are done in parallel.

Figure 5 illustrates the parallel architecture of the VN. The eLLR block generates the intrinsic LLR value $I^+(V_i^{a\oplus})$

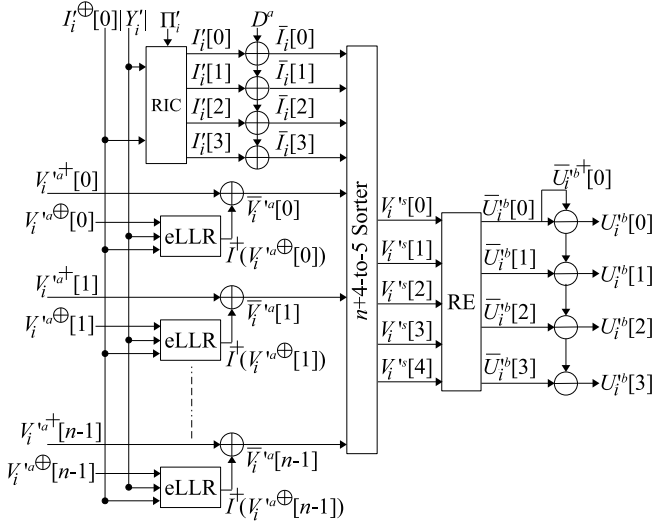

Fig. 5. VN architecture

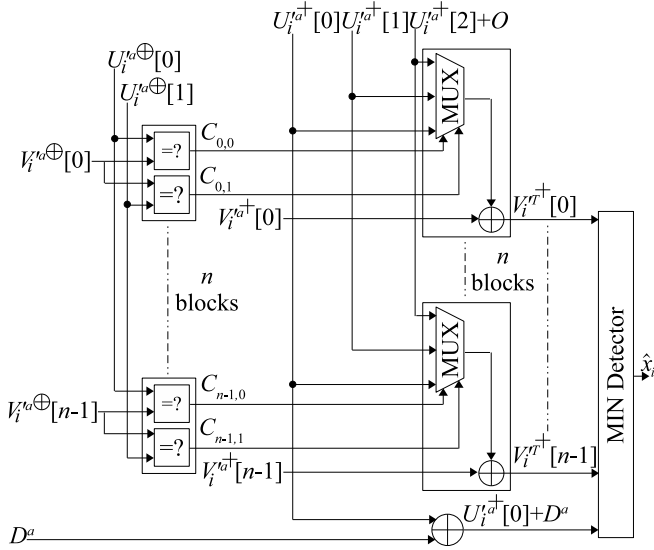

Fig. 6. DM architecture

thanks to Y_i' and $I_i^{\oplus}[0]$ that will be added on $V_i^{a\oplus}$ to generate $\bar{V}_i^{a\oplus}$. The Regeneration of Intrinsic Candidates (RIC) block is to regenerate the intrinsic candidates $\{I_i^{\oplus}[0], \dots, I_i^{\oplus}[3]\}$. Then, the offset value $D^a \in \{D_g, D_{10}, D_{11}\}$ associated to V_i' is added on $\{I_i^{\oplus}[0], \dots, I_i^{\oplus}[3]\}$ to generate \bar{I}_i^{\oplus} . In section II.C, we showed that the output is generated by detecting the most reliable not redundant GF symbols from $\{V_i^{a\oplus}[0], \dots, V_i^{a\oplus}[n-1], I_i^{\oplus}[0], \dots, I_i^{\oplus}[3]\}$. To reduce the complexity, the sorting and the redundant elimination are separated. First, the vector $V_i^{s\oplus}$ of $n_{min} + n_{\delta}$ couples having the lowest LLR values are detected from $\{V_i^{a\oplus}[0], \dots, V_i^{a\oplus}[n-1], I_i^{\oplus}[0], \dots, I_i^{\oplus}[3]\}$, then the outputs are generated by detecting, from $V_i^{s\oplus}$, the n_{min} couples without redundant GF symbols. In this work $n_{\delta} = 1$. Thus, the $n+4$ -to-5 Sorter block, $n \in \{n_{FB}, n_s\} = \{16, 20\}$, generates $V_i^{s\oplus}$ that is having the $4+1=5$ couples of lowest LLR values among $\{V_i^{a\oplus}[0], \dots, V_i^{a\oplus}[n-1], I_i^{\oplus}[0], \dots, I_i^{\oplus}[3]\}$.

The Redundant Elimination (RE) block generates $U_i^{b\oplus}$ by detecting the 4 couples from $V_i^{s\oplus}$ that are different in terms of GF values and having lowest LLR values. Finally, the normalization of $\bar{U}_i^{b,+}$ (7) is performed.

Figure 6 shows the parallel architecture of the DM block. There are $2n$ comparators operating in parallel to check whether $V_i^{a\oplus}[t_0] = U_i^{a\oplus}[t_1]$ or not, $t_0 = 0, \dots, n-1$ and $t_1 = 0, 1$. We compare $V_i^{a\oplus}[t_0]$ to $U_i^{a\oplus}[0]$ and $U_i^{a\oplus}[1]$ as described in equation (9). The 3-to-1 MUXs operate as follows: if $V_i^{a\oplus}[t_0] = U_i^{a\oplus}[t_1]$ then the output is $U_i^{a\oplus}[t_1]$, otherwise, the output is $U_i^{a\oplus}[2]+O$. The output of every 3-to-1 MUX is added to its associated $V_i^{a\oplus}[t_0]$. Only the couple $U_i^{\oplus}[0]$ is considered from the set $\{U_i^{\oplus}[0], U_i^{\oplus}[1], U_i^{\oplus}[2]\}$ where its LLR value is added to the default value D^a . Finally, the MIN Detector block selects from $\{V_i^{\oplus}[0], \dots, V_i^{\oplus}[n-1], U_i^{\oplus}[0]\}$ the decided symbol \hat{x}_i' having the lowest LLR value.

The last operation in CN-VN is the inverse permutation performed using Ψ^{-1} to reorder $\{U_0^{b\oplus}, \dots, U_{11}^{b\oplus}\}$ and $\{\hat{x}'_0, \dots, \hat{x}'_{11}\}$ to their original order.

IV. PROPOSED PARALLEL AND PIPELINED DECODER

This section describes the global architecture of the decoder, where the inputs/outputs of each block are described along with the functionality being performed. The memory system and the timing diagram of the decoding process are discussed. The global decoder is based on the CN-VN unit described in Section III which has been customized to offer the best performance-complexity trade-off for the considered code. This CN-VN unit can be modified to meet the specifications of any other NB-LDPC code and thus design the associated decoder. In the following, we use the index $k(j, i)$, $i = 0, \dots, 11$, $j = 0, \dots, M-1$ and $k(j, i) \in \{0, \dots, 143\}$, to refer to a quantified symbol $Y_{k(j,i)}$ for a specific $VN_{k(j,i)}$. For instance, when CN_0 is being processed after the extension of the prototype matrix \mathcal{H} , the set $\{VN_0, VN_{12}, VN_{24}, VN_{36}, VN_{48}, VN_{60}, VN_{72}, VN_{84}, VN_{96}, VN_{108}, VN_{120}, VN_{132}\}$ is considered and hence $k(0, 0) = 0$, $k(0, 1) = 12, \dots$, $k(0, 11) = 132$ are the indexes associated to $VN_0, VN_{12}, \dots, VN_{132}$ respectively. These indices along with the associated GF symbols h_i are indicated by the PCM of the code.

A. Architecture overview

The architecture of the global decoder is shown in Fig. 7. The input messages are being received by blocs of 8 symbols. The 8 symbols are being received according to the order of the VNs that are connected to CN_0, \dots, CN_{11} respectively. In more details, the first set of 8 received symbols is $\{Y_0, Y_{12}, Y_{24}, Y_{36}, Y_{48}, Y_{60}, Y_{72}, Y_{84}\}$ (all of them belong to CN_0), the second set is $\{Y_{96}, Y_{108}, Y_{120}, Y_{132}, Y_1, Y_{13}, Y_{25}, Y_{37}\}$ (the first 4 symbols belong to CN_0 and the last 4 symbols belong to CN_1), \dots , etc. The different blocks are described in the following.

Intrinsic Router Block (IRB): the observed symbols and their intrinsic messages generated by LLRGB are being

in the first cell of the first RAM block ($\text{RAM}_0[0]$), while the intrinsic messages of VN_{50} are stored in the third cell of the fifth RAM block ($\text{RAM}_4[2]$), and so on. The data of every VN_k , $k = 0, 1, \dots, 143$, is composed of the absolute values of the channel observations $|Y_{k,p}|$, $p = 0, 1, \dots, 5$, represented each on 5 bits, and the hard decision $I^\oplus[0]$ along with the indexes of the first 3 minimum values $\Pi_k = \{\pi_k[0], \pi_k[1], \pi_k[2]\}$ of the sorted Y_k . Note that the indexes $\pi[i]$ are on 3 bits each, since they contain the sorting indexes of 6 symbols. The required information is concatenated to be stored in each cell as: $(I_k^\oplus[0] \& \Pi_k \& |Y_k|)$, where $\&$ represents the concatenation operation. The cumulative length of each cell is equal to $6 + 3 + 3 + 3 + 6 \times 5 = 45$ bits. Every intrinsic RAM has its own read address and write address.

The non-zero elements of the PCM and their inverse are stored in a ROM block. The ROM has 2 words, one for each layer, where each word is of size equal to $(6 \times 2) \times 12 = 144$ bits since every non-zero GF value h_i and its inverse h_i^{-1} consists of 6-bit words, and $i = 0, \dots, 11$.

It is interesting to evaluate the memory bandwidth of the proposed architecture per iteration and per symbol, then, per bit. In an iteration, a VN is implied in two CNs. For each CN, it reads $(|Y|, \Pi, I^\oplus[0])$ in the intrinsic RAM (thus $30+9+6 = 45$ bits) and reads the U^a message in the extrinsic RAM (42 bits from 4 GF symbols and 3 non-zero LLRs) and write back the U^b message (thus 42 bits) in the extrinsic RAM. Thus, the total number of read/write operations to process a symbol during an iteration is $2(45 + 2 \times 42) = 258$ bits. Since a symbol contains 6 bits of information, it gives in average 43 bits of read/write memory access per message bit per decoding iteration. This number should be compared to a binary LDPC decoder. Assuming a $d_v = 3$ and a soft-output based CN architecture [25], with the soft-output coded on 8 bits and the extrinsic on 6 bits, then each iteration will require $d_v \times 2(8 + 6) = 84$ bits of read/write memory access per message bit per decoding iteration. The natural conclusion that may goes against the common belief is that **NB-LDPC code can decrease the memory bandwidth by almost 50% compared to binary LDPC code**. The size of the memory is also reduced from $(8 + 3 \times 6) = 26$ per message bits for LDPC down to $(45 + 2 \times 42)/6 = 21.5$ bits in average per message bits for the NB-LDPC.

C. Timing diagram

The control of the decoder works with a periodicity of $2 \times 24 = 48$ CC as shown in Fig. 9. In this figure, lines 3 to 8 show the processing of frame k between cycles 0 and 23 while lines 9 to 13 show the processing of frame k between cycles 24 and 47. The $N = 144$ received symbols of the k^{th} frame are received in 18 CC from cycle numbers 0 up to 17 by a group of 8 symbols and sent directly to the LLRGB. After two CCs of latency, the LLRGB generate all the side information related to the received symbol (i.e. permutation Π and intrinsic message I). The data is reordered by the IRB component and stored in their appropriate location in the intrinsic memory RAMs and in the extrinsic memory RAMs. At cycle index 18, the intrinsic information of the VNs connected to CN_0

are stored in memory and the processing of the layers L_1 and L_2 starts from cycle number 19 up to cycle number $18 + 24$ (see line 10 of Fig. 9). Then, 10 cycles after the beginning of the processing of the first CN of frame k , i.e., at CC number $19+9 = 28$ (see line 11 of Fig. 9) the decision on the VNs associated to the first CN are output. Note that the extrinsic message requires 5 more CC to be generated (not shown in the Fig. 9). After 18 CC (see PTB description), a codeword is said decoded if all the decisions generated by layer 1 verify all the parity CNs (at CC number 47), just in time to start again the loading of a new codeword at cycle number 48. As seen in Fig. 9, the processing of a given frame requires the utilization of a given component at most 24 CC. During the remaining 24 CC, a different frame is processed. In Fig. 9, we also show, for illustration, the processing of iteration (ite.) l and $l + 1$ of the frame $k - 1$. Note that the frame order at the output of the decoder can be changed.

The number of CCs to decode a frame is thus $48 \times n_{it,f}$, where $0 < n_{it,f} \leq n_{max,it}$ is the number of iterations to decode a frame. Since two frames are decoded in parallel, the average number of CC to decode a codeword is $24 \times n_{av,it}$ CCs.

This parallelism in the simultaneous processing of two consecutive frames requires the duplication of the intrinsic and extrinsic RAMs to store the data of two frames. To summarize, looking at the global execution of the decoder, the 19-CC latency for preparing the data (shown in Fig. 9) and the 16-CC latency of the CN are not considered when evaluating the execution time of the decoder (which has a direct impact on the throughput rate). We also note that without the duplication of the RAMs, that allowed the parallel processing of two consecutive frames, the 16-CC latency of the CN has to be considered as a part of the execution time at each iteration. This is due to the fact that CN_{23} and CN_0 share the same variable VN_{12} , which prevents the start of the second iteration before the processing of CN_{23} is ended. Therefore, $M = 24$ CCs is the latency of one iteration.

V. SIMULATION RESULTS

As described in Section III.B, some bubbles from the H-CN are eliminated to reduce the computational complexity but at the cost of a slight performance loss. In order to compensate this performance degradation, the global number of iterations within the decoder is increased to 30 iterations. Fig. 10 shows simulation results for the BP decoder [5], the well-known FB-CN-based decoder [26], proposed decoder, and the Sum-Product (SP)-based decoder. The BP and the FB-CN-based NB-LDPC code have the same parameters: $K = 120$ GF(64) symbols, $N = 144$ GF(64) symbols and $\text{CR} = 5/6$ (equivalently, $K = 720$ bits and $N = 864$ bits). The SP-based B-LDPC code is of length $N = 864$ bits, $K = 720$ bits and $\text{CR} = 5/6$ but designed over GF(2). The BP and the FB CN-based decoders are simulated using layered scheduling while the proposed decoder, in its hardware version, is implemented using the sub-flooding scheduling. This is due to the fact that by its nature, the new parallel decoder allows to start a new CN processing at each clock cycle which leads to

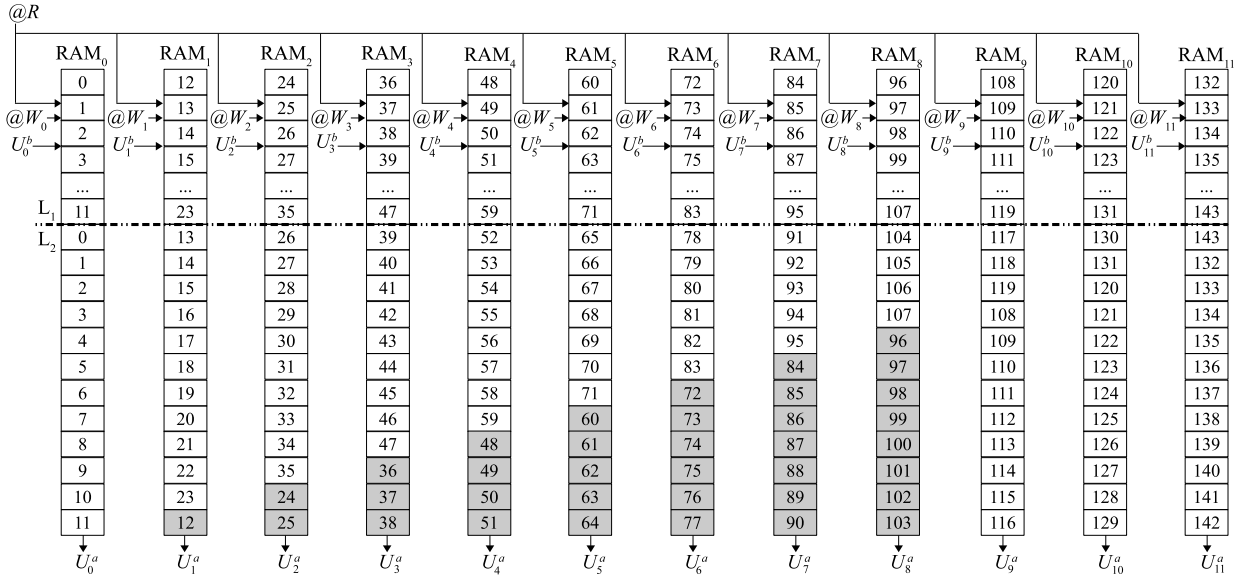

Fig. 8. Extrinsic RAM Banks in RAM ROM Banks block.

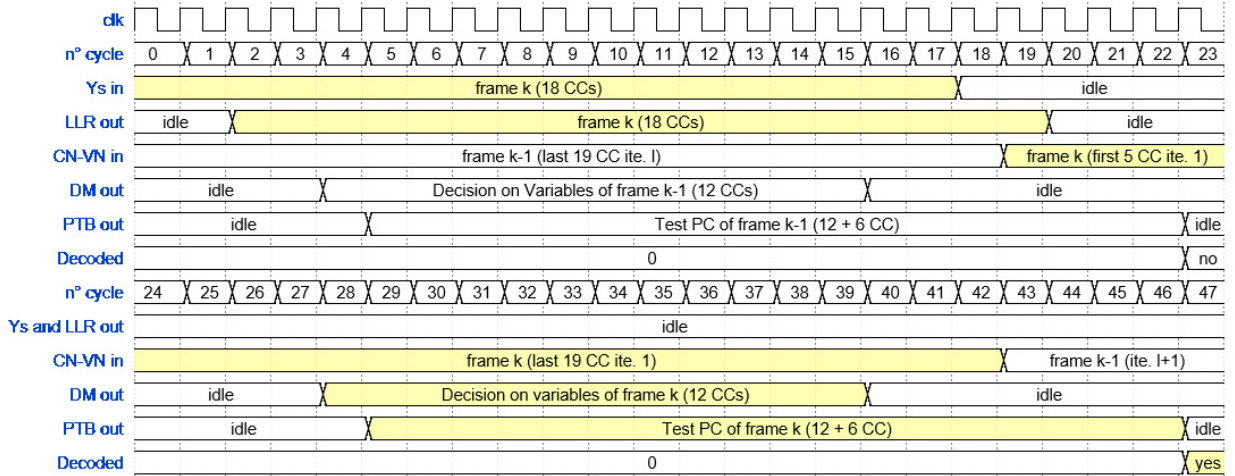

Fig. 9. Timing diagram of the overlapping phase.

reach the second layer of CNs without having completed the processing of the VNs being started in the first layer. Therefore, when the layered scheduling is implemented, the proposed decoder needs to enter an idle time waiting the availability of the required data. To avoid this idle time, the sub-flooding schedule has been adopted.

We consider Monte Carlo simulations under the AWGN channel, QPSK modulation and the LLR values quantized on $b = 6$ bits. A performance loss of 0.08 dB is observed between the proposed decoder with 30 iterations and the references floating point BP and fixed point FB-CN decoding algorithms with 8 iterations. Although the proposed decoder is implemented with a maximum number of iterations equal to 30, it is the average number of iterations that will be taken into consideration when the throughput rate will be evaluated. This will be discussed in more details in next section. When compared to its B-LDPC counterpart, the proposed decoder presents a gain of 0.3 dB at a FER of 10^{-3} . It is worth mentioning that the NB-LDPC code

offers an important advantage in terms of spectrum efficiency since high order modulations are suitable to be used with NB-LDPC codes designed over $GF(q > 2)$, where there is no need for iterative demodulation. To evaluate performance in a short time, the complete digital communication chain is implemented on an FPGA device. The source, encoder, channel and decoder are implemented using VHDL. The source generates random bits that are encoded, BPSK modulated, affected by an AWGN, then demodulated and decoded. A hardware discrete channel emulator is implemented to emulate the AWGN channel. We used the Xilinx KC705 FPGA DevKit containing a Kintex 7 where the simulation results match the emulation results.

VI. IMPLEMENTATION RESULTS

This section discusses the throughput calculation and the post-synthesis results on 28-nm TSMC technologies. Since the decoding throughput is highly dominated by the average

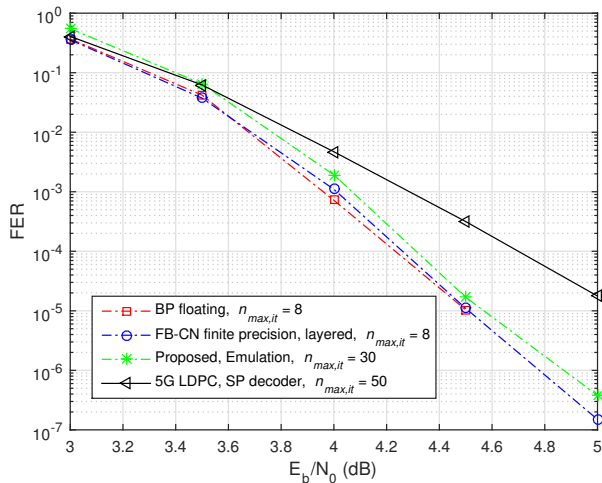

Fig. 10. FER performance for a (144, 120) NB-LDPC code over GF(64): Proposed decoder vs FB CN-based decoder and (864, 720) B-LDPC code over GF(2) SP decoder.

TABLE II
AVERAGE NUMBER OF ITERATIONS AND THROUGHPUT.

| E_b/N_0 (dB) | Low | 3 | 3.5 | 4 | 4.5 | 5 |
|-------------------|-----|------|------|------|------|-------|
| $n_{av,it}$ | 30 | 18.3 | 7.25 | 3.4 | 2.45 | 1.93 |
| Throughput (Mb/s) | 650 | 1060 | 2680 | 5730 | 7950 | 10100 |

number of iterations $n_{av,it}$, we study its variation versus the signal-to-noise ratio (i.e., E_b/N_0). Table II shows that $n_{av,it}$ significantly varies with low E_b/N_0 , and decreases rapidly when E_b/N_0 changes from 3 dB to 3.5 dB, then $n_{av,it} = 1$ from $E_b/N_0 > 8$ dB. The throughput calculation is expressed as:

$$\text{Throughput (Mb/s)} = \frac{\log_2(q) \times K \times F_{clk}}{n_{av,it} \times M}. \quad (11)$$

TABLE III
COMPARISON OF STATE-OF-THE-ART NB-LDPC DECODERS (ASICs).

| | [15] | [27] | [7] | FPHD |
|--------------------|---------------|-----------------------|--------------|--------------|
| Techno (nm) | 40 → 28 | 90 → 28 | 65 → 28 | 28 |
| Design | Synthesis | Synthesis | Silicon | Synthesis |
| N (symbols) | 3888 | 837 | 160 | 144 |
| CR | 8/9 | 13/15 | 1/2 | 5/6 |
| GF | 4 | 32 | 64 | 64 |
| Decoding Algorithm | T-EMS Layered | IL-MwBRB sub-flooding | EMS Flooding | EMS Flooding |
| Iterations | 10 | 10 | 10-30 | 1-30 |
| F_{clk} (MHz) | 1,000 | 665 | 1,000 | 650 |
| C (NAND) | 4 M | 4.54 M | 2.78 M | 0.79 M |
| T (Gbps) | 0.36 | 69.6 | 1.7 | 1.1→10.0 |
| E (T/C) | 0.9 | 15.3 | 0.63 | 1.3→24.7 |

Synthesis results for our design lead to a maximum clock frequency $F_{clk} = 650$ MHz, and thus a throughput that varies from 1.06Gb/s up to 19.5 Gb/s (Table II). A comparison of the Full Parallel Hybrid CN Decoder (FPHD) implementation

and three state-of-the-art decoders [15], [27], [7] is presented in Table III. All these decoders achieve ultra-high throughput thanks to parallelism. To take into account the different technologies, the clock frequency of a design in technology θ -nm, $\theta \in \{40, 65, 90\}$, is multiplied by the scaling factor $\theta/28$ before being compared to the proposed decoder (28-nm technology). The maximum allowed frequency after scaling is upper bounded by 1,000 MHz. The last three lines of the table correspond to the hardware complexity C expressed in millions of NAND gates, the input decoding throughput T (in Gbits/s or Gbps) and the hardware efficiency E defined as the ratio $E = T/C$ (in Gbps per million NAND gates), respectively. Let us first compare the FPHD to the architecture proposed in [15]: FPHD consumes 0.79 M NAND gates, runs at 650 MHz and varies the number of iterations from 1 to 30, while the design in [15] consumes 4 M NAND gates, runs at 1000 MHz and iterates 10 times. In terms of throughput, FPHD outperforms [15] for $E_b/N_0 > 3.7$ dB with $FER \approx 10^{-2}$. However, the throughput efficiency of FPHD is better for any $E_b/N_0 > 3$ dB.

Compared to [27], both designs present the same frequency, and our design reduces the number of NAND gates by a factor of 5.74. The decoder proposed in [27] offers a higher throughput for the entire range of E_b/N_0 . Nevertheless, in terms of hardware efficiency, FPHD outperforms [27] at high SNR. It is worth mentioning that in [27] the performance loss is significant because of the symbol-flipping algorithm they use (i.e., only one symbol is considered among q candidates). Finally, our FPHD consumes 1.99M NAND gates less than [7], but runs at a lower frequency. However, our FPHD provides higher throughput for $E_b/N_0 > 3.5$ dB and hence shows a better hardware efficiency in a factor ranging from 2.1 up to 39.3.

VII. CONCLUSION AND PERSPECTIVES

This paper was dedicated to an ultra-high-throughput EMS NB-LDPC decoder implementation based on full parallel architectures. We particularly focused on a GF(64) (144, 120) code with high rate (CR = 5/6). A number of architectural strategies made possible the 10 Gb/s throughput for high SNR, which represents a throughput efficiency gain in the order of 6 to 50 (depending on the SNR) compared to [17]. Beside the careful optimization of the number of bubbles in each ECN, several original ideas have been presented in the paper to optimize the prior hybrid architecture. The main idea is to merge the CN and the VN processing with the suppression of the sorting operation after the CN processing thanks to the use of a predefined bubble position to get the default check to variable LLR value for the VN processing. This leads to both a reduced hardware complexity and a reduced memory bandwidth (almost 50% of reduction compared to a binary LDPC code). The two-step generation of the variable-to-check messages, i.e., the selection of the $n_{min} + n_\delta$ messages with smallest LLR, then the extraction of n_{min} smallest LLR with distinct GF values, is also a new contribution.

As a proof of concept, the full design of a small code has been performed. Due to the small size of the code, two

codewords are decoded in parallel to avoid idle cycles in the hardware. Simulation results showed that the proposed decoder (sub-flooding scheduling and $n_{max,it} = 30$) outperforms the (860, 720) binary-LDPC SP used in the 5G standard by 0.3 dB at FER of 10^{-3} . Emulation results on FPGA show that the proposed decoder introduces only a 0.08 dB penalty loss compared to the reference floating point BP layered decoder with $n_{max,it} = 8$.

There are many possible extensions of this work. The first one is to find the optimal sets of parameters of the hybrid CN-VN architecture in the general case (different code length, code rate and Galois Field order). From this study, it would be possible to design a flexible hardware parallel architecture able to decode a set of codes with different coding rates and lengths. In terms of hardware, the advantages of the proposed CN-VN unit should be even greater when the code length is high enough so that a layered decoder is feasible without any memory conflict.

REFERENCES

- [1] M. C. Davey and D. J. C. MacKay, "Low density parity check codes over GF(q)," *IEEE Communications Letters*, vol. 2, no. 6, pp. 159–166, June 1998.
- [2] S. Pfletschinger, A. Mourad, E. Lopez, D. Declercq, and G. Bacci, "Performance evaluation of non-binary LDPC codes on wireless channels," in *Proceedings of ICT Mobile Summit*. Santander, Spain, June 2009.
- [3] D. Declercq, M. Colas, and G. Gelle, "Regular GF(2^q)-LDPC coded modulations for higher order QAM-AWGN channel," in *Proc. ISITA*. Parma, Italy, Oct. 2004.
- [4] E. Boutillon, L. Conde-Canencia, and A. A. Ghouwayel, "Design of a GF(64)-LDPC decoder based on the EMS algorithm," *IEEE Transactions on Circuits and Systems I: Regular Papers*, vol. 60, no. 10, pp. 2644–2656, Oct 2013.
- [5] M. Davey and D. MacKay, "Low-density parity check codes over GF(q)," *Communications Letters, IEEE*, vol. 2, no. 6, pp. 165–167, June 1998.
- [6] D. J. C. MacKay and M. Davey, "Evaluation of Gallager codes for short block length and high rate applications," in *Proc. IMA Workshop Codes, Syst., Graphical Models*, 1999.
- [7] Y. S. Park, Y. Tao, and Z. Zhang, "A fully parallel nonbinary LDPC decoder with fine-grained dynamic clock gating," *IEEE Journal of Solid-State Circuits*, vol. 50, no. 2, pp. 464–475, Feb 2015.
- [8] F. Cai and X. Zhang, "Relaxed min-max decoder architectures for nonbinary low-density parity-check codes," *IEEE Transactions on Very Large Scale Integration (VLSI) Systems*, vol. 21, no. 11, pp. 2010–2023, Nov 2013.
- [9] D. Declercq and M. Fossorier, "Decoding algorithms for nonbinary LDPC codes over GF(q)," *IEEE Trans. Comm.*, vol. 55, no. 4, pp. 633–643, April 2007.
- [10] A. Voicila, D. Declercq, F. Verdier, M. Fossorier, and P. Urard, "Low complexity, low memory EMS algorithm for non-binary LDPC codes," in *IEEE Intern. Conf. on Commun., ICC'2007*. Glasgow, England, June 2007.
- [11] D. Declercq and M. Fossorier, "Decoding algorithms for nonbinary LDPC codes over GF(q)," *IEEE Transactions on Communications*, vol. 55, no. 4, pp. 633–643, April 2007.
- [12] A. Voicila, D. Declercq, F. Verdier, M. Fossorier, and P. Urard, "Low-complexity decoding for non-binary LDPC codes in high order fields," *IEEE Transactions on Communications*, vol. 58, no. 5, pp. 1365–1375, May 2010.
- [13] E. Li, D. Declercq, and K. Gunnam, "Trellis-based extended Min-Sum algorithm for non-binary LDPC codes and its hardware structure," *IEEE Transactions on Communications*, vol. 61, no. 7, pp. 2600–2611, July 2013.
- [14] J. O. Lacruz, F. García-Herrero, J. Valls, and D. Declercq, "One minimum only trellis decoder for non-binary low-density parity-check codes," *IEEE Transactions on Circuits and Systems I: Regular Papers*, vol. 62, no. 1, pp. 177–184, Jan 2015.
- [15] D. D. Erbao Li and K. Gunnam, "Trellis-based extended min-sum algorithm for non-binary LDPC codes and its hardware structure," *Communications, IEEE Transactions on*, no. 61(7), pp. 2600–2611, July 2013.
- [16] H. P. Thi and H. Lee, "Basic-set trellis Min-Max decoder architecture for nonbinary LDPC codes with high-order Galois fields," *IEEE Transactions on Very Large Scale Integration (VLSI) Systems*, vol. 26, no. 3, pp. 496–507, March 2018.
- [17] C. Marchand, E. Boutillon, H. Harb, L. Conde-Canencia, and A. Al Ghouwayel, "Hybrid check node architectures for NB-LDPC decoders," *IEEE Transactions on Circuits and Systems I: Regular Papers*, vol. 66, no. 2, pp. 869–880, Feb 2019.
- [18] P. Schlafer, N. Wehn, M. Alles, T. Lehnigk-Emden, and E. Boutillon, "Syndrome based check node processing of high order NB-LDPC decoders," in *Telecommunications (ICT), 2015 22nd International Conference on*, April 2015, pp. 156–162.
- [19] V. Rybalkin, P. Schläfer, and N. Wehn, "A new architecture for high speed, low latency NB-LDPC check node processing for GF(256)," in *2016 IEEE 83rd Vehicular Technology Conference (VTC Spring)*, May 2016, pp. 1–5.
- [20] C. Marchand and E. Boutillon, "NB-LDPC check node with pre-sorted input," in *2016 9th International Symposium on Turbo Codes and Iterative Information Processing (ISTC)*, Sept 2016, pp. 196–200.
- [21] H. Harb, C. Marchand, A. Ghouwayel, A. Conde-Canencia, L., and E. Boutillon, "Pre-sorted forward-backward NB-LDPC check node architecture," in *SIPS*, 2016.
- [22] H. Harb, A. C. Al Ghouwayel, and E. Boutillon, "Parallel generation of most reliable LLRs of a non-binary symbol," *IEEE Communications Letters*, vol. 23, no. 10, pp. 1761–1764, Oct 2019.
- [23] C. Lin, S. Tu, C. Chen, H. Chang, and C. Lee, "An efficient decoder architecture for nonbinary LDPC codes with extended min-sum algorithm," *IEEE Transactions on Circuits and Systems II: Express Briefs*, vol. 63, no. 9, Sept 2016.
- [24] M. J. S. Amin Farmahini-Farahani, Henry J. Duwe III and K. Compton, "Modular design of high-throughput, low-latency sorting units," *IEEE TRANSACTIONS ON COMPUTERS*, vol. 62, no. 7, pp. 1389–1402, July 2013.
- [25] M. Rovini, F. Rossi, P. Ciao, N. L'Insalata, and L. Fanucci, "Layered decoding of non-layered LDPC codes," in *9th EUROMICRO Conference on Digital System Design (DSD'06)*, Aug 2006, pp. 537–544.
- [26] H. Wymeersch, H. Steendam, and M. Moeneclaey, "Log-domain decoding of LDPC codes over GF(q)," in *Communications, 2004 IEEE International Conference on*, vol. 2, June 2004, pp. 772–776.
- [27] J. Tian, J. Lin, and Z. Wang, "A 21.66 Gbps Nonbinary LDPC decoder for high-speed communications," *IEEE Transactions on Circuits and Systems II: Express Briefs*, vol. PP, no. 99, pp. 1–1, 2017.