



HAL
open science

Modeling Implicit Learning: Extracting Implicit Rules from Sequences using LSTM

Ikram Chraibi Kaadoud, Nicolas P. Rougier, Frédéric Alexandre

► **To cite this version:**

Ikram Chraibi Kaadoud, Nicolas P. Rougier, Frédéric Alexandre. Modeling Implicit Learning: Extracting Implicit Rules from Sequences using LSTM. WiML 2019 - 14th Women in Machine Learning Workshop at NeurIPS 2019, Dec 2019, Vancouver, Canada. hal-02491042

HAL Id: hal-02491042

<https://hal.science/hal-02491042>

Submitted on 29 Mar 2021

HAL is a multi-disciplinary open access archive for the deposit and dissemination of scientific research documents, whether they are published or not. The documents may come from teaching and research institutions in France or abroad, or from public or private research centers.

L'archive ouverte pluridisciplinaire **HAL**, est destinée au dépôt et à la diffusion de documents scientifiques de niveau recherche, publiés ou non, émanant des établissements d'enseignement et de recherche français ou étrangers, des laboratoires publics ou privés.

Trust in neural networks is often correlated with an **understanding of the predictions** of these networks. However, the latter are rightly described as **"black boxes"**, an opaque set where only inputs and outputs are accessible. This work deals precisely with the **interpretability** of neural networks. In that context, we propose a generic solution for **extracting the implicit representation developed by recurrent networks equipped with Long units Short Term Memory (LSTM)**, particularly in the context of learning sequences from grammars not binary. Getting our inspiration from the studies on the **implicit sequential learning in humans**, we propose a method for extracting implicitly encoded rules in the form of graphs, with different rating systems, which **clarify knowledge about the temporal arrangement and continuous state space of the hidden layer of the network**.

Keywords: Recurrent networks, LSTM, Learning of sequences, Extraction of rules, Automata, Interpretability of neural networks.

A – Introduction & Context

A.1 - Implicit sequential learning in humans

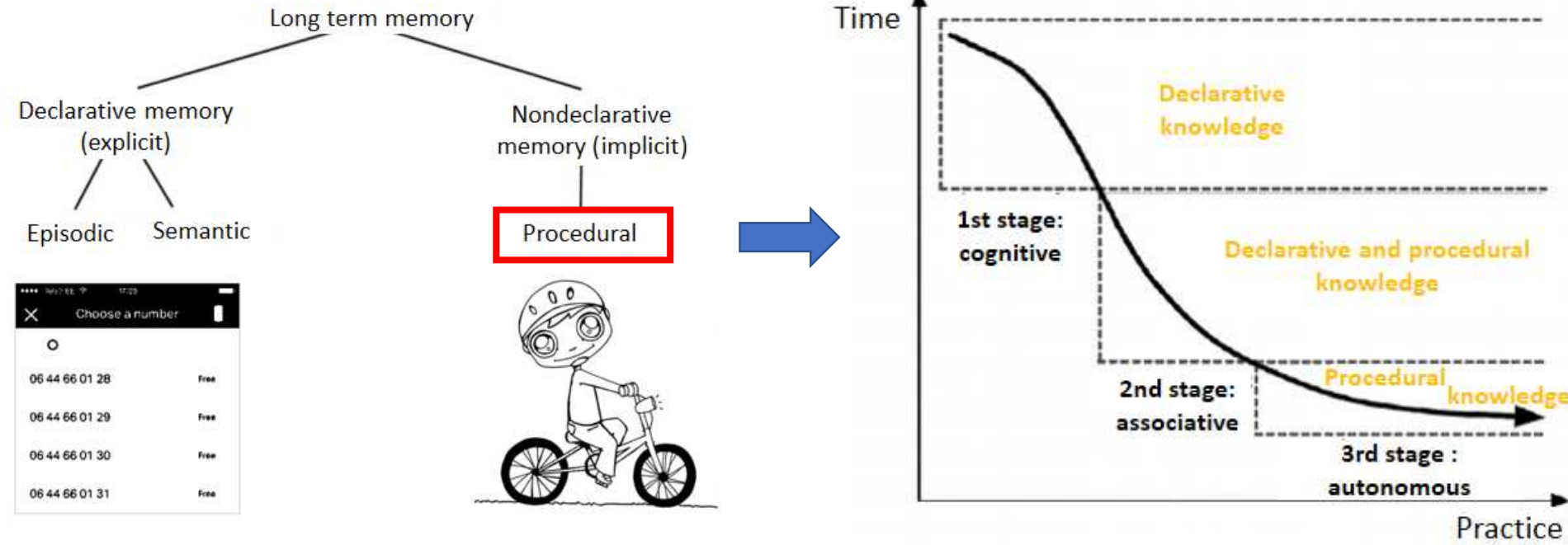

Fig.1: A partial taxonomy of the different memories (Squire and Zola, 1996) and procedural knowledge acquisition according practice and time (Kim et al,2013)

A.2 – Modeling implicit learning: the Simple Recurrent Network (SRN) approach

- Network with a feedback loop that allow to maintain a representation of the temporal context associated with the inputs (Elman, 1988)
- Framework for Modeling Sequential Learning in Humans (Cleermans et al, 1991)
- Main limitation: Attenuation of the temporal context

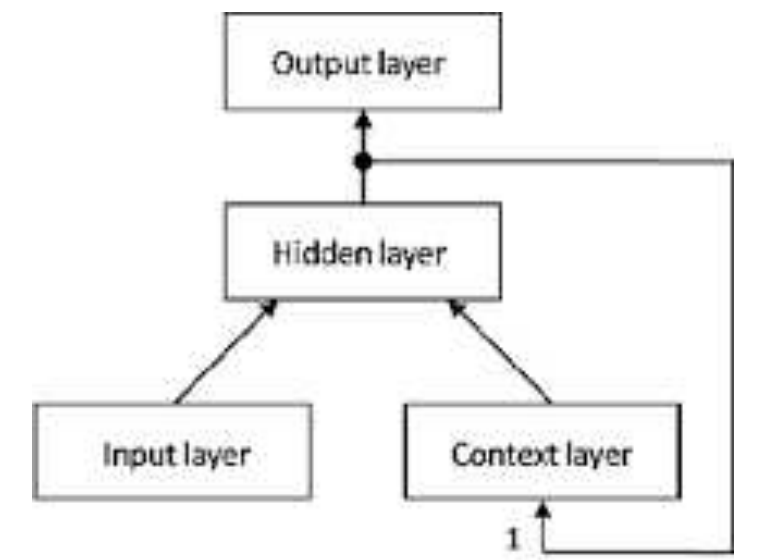

Fig.2: Architecture of the SRN

B - Grammars

Non-binary artificial grammar proposed for human experiments in measuring time respond experience in cognitive psychology (Reber, 1967)

Reber grammar (RG)

Embedded Reber grammar (ERG)

Continuous Embedded Reber grammar (CERG)

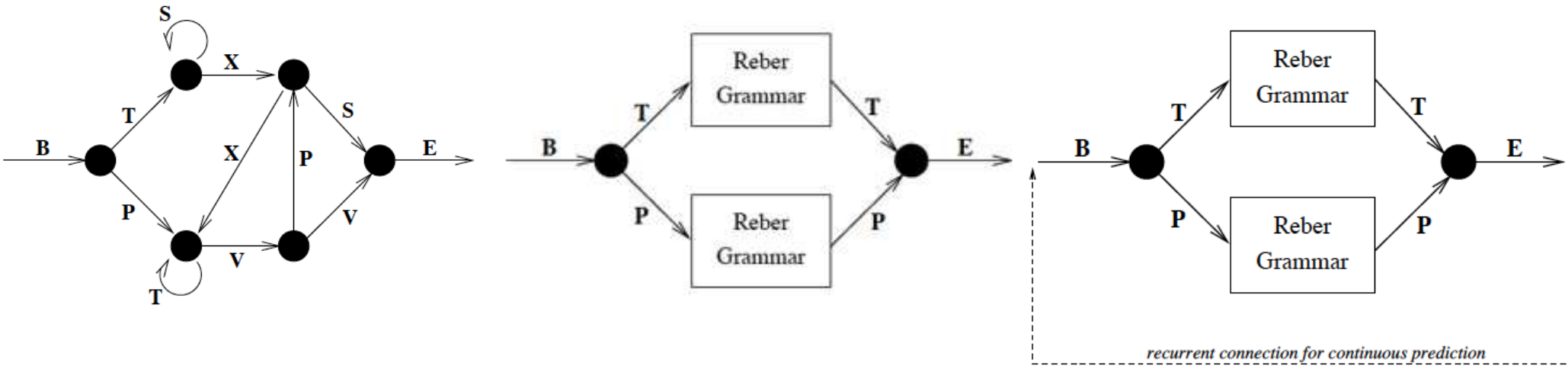

C – Long Short Term Memory (LSTM) approach

Hypothesis: A network using LSTM, a model with internal and explicit representation of time, can develop an implicit representation of the rules hidden in sequences and predict according it

RNN-LSTM

Architecture

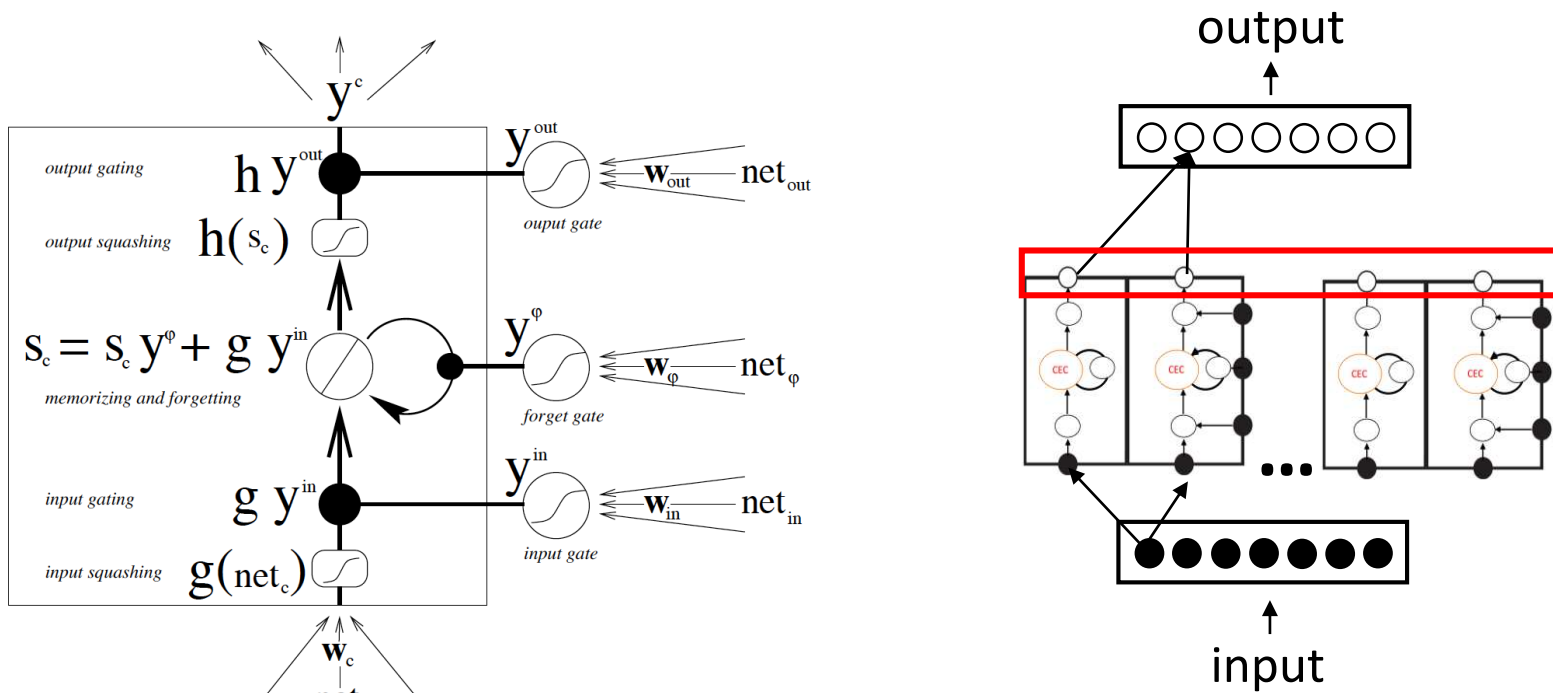

Fig.3: LSTM unit according (Gers, 1999) and its implementation in our network

3 layers:

- An input and output layer of 7 units each
- 1 hidden layer (1) of 4 blocks, of 2 cells each

Parameters : Learning Rate : 0.5 (x 0,99 each 100 time steps)

	RG & ERG	CERG
Learning	200,000 grammatical sequences	1 flow of 100,000 successive symbols
Test	10 data sets of : • 20,000 grammatical sequences • 130,000 non-grammatical sequences	10 flows of 100,000 symbols.
Results	• High recognition (close to 100%) of grammatical sequences as valid • Low recognition (close to 0%) of non-grammatical sequences as valid	100% correct predictions according (Gers, 1999) on 30,000 flows of 100,000 symbols

D – Rules extraction process from RNN-LSTM

1) Quantification using kmeans: k in [6 ; 500] on 5000 hidden patterns (10 simulations)

2) Rules extraction process for each k value:

Time steps	t ₀	t ₁	t ₂	t ₃
Input symbol	B	T	X	S
Index of the hidden pattern (HP)	0	1	2	3
Index of the associated cluster (C)	0	4	2	3

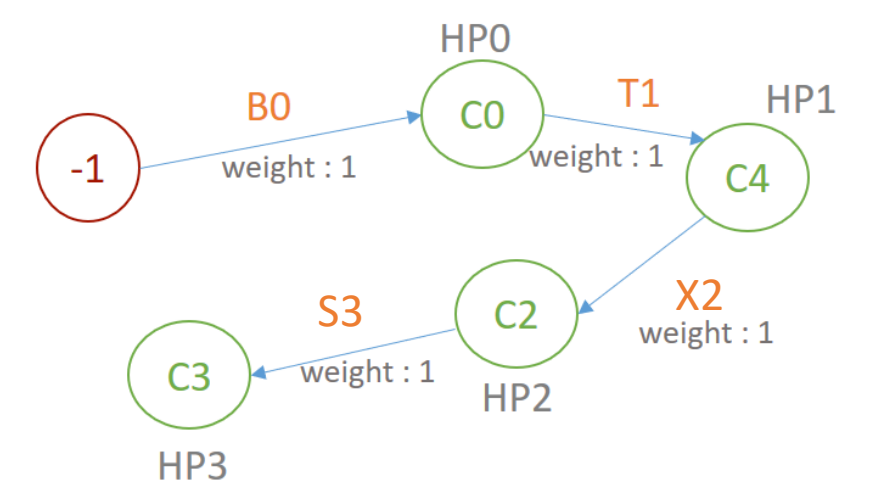

3) Validation of extracted automata

E – Results

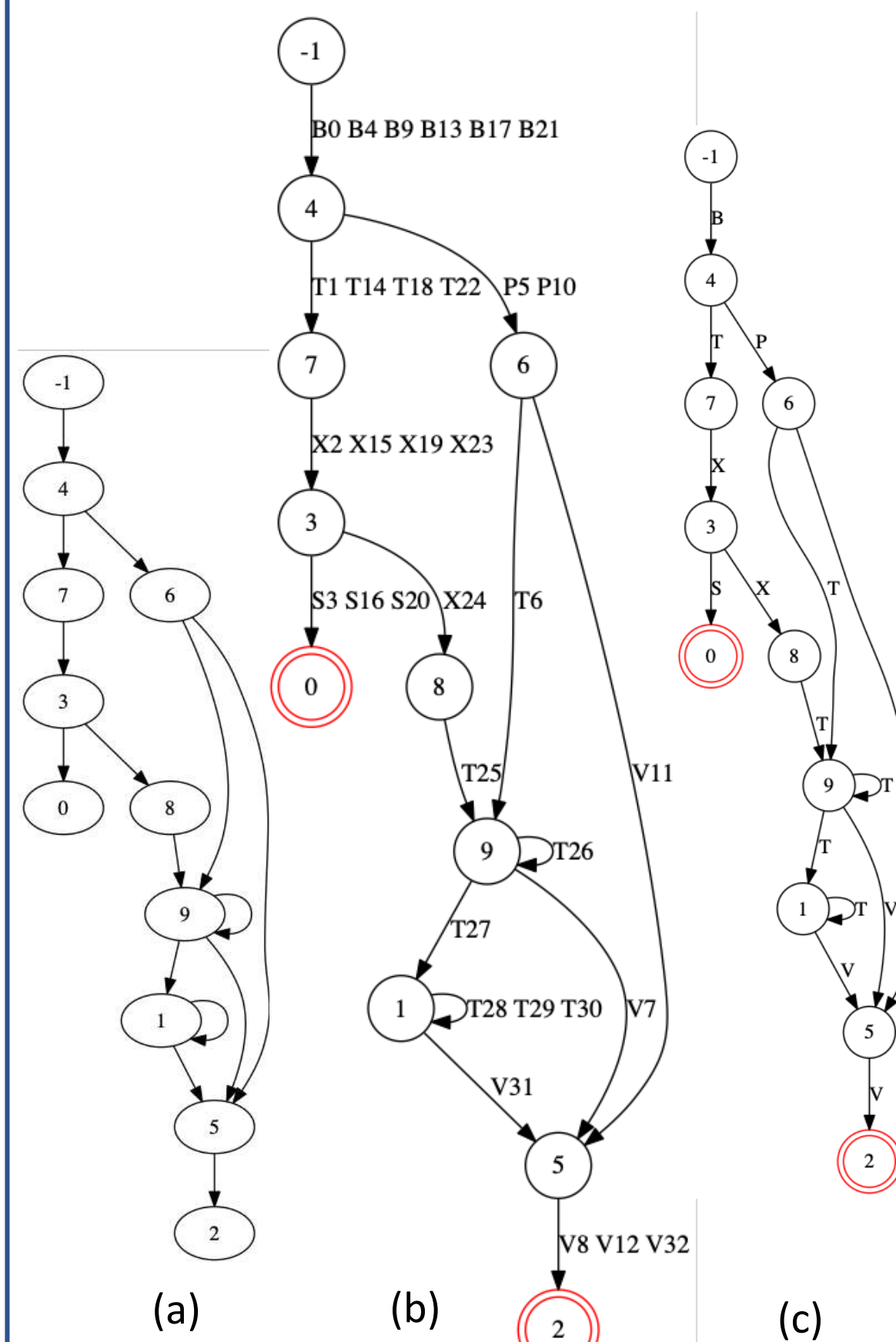

Fig.4: Extraction in RG context with a k-means algorithm (k=10): **a** - Unlabeled automata representing the arrangement of the clusters. **b** - Long-label automata expliciting the temporal routing of patterns and "the behavior" of the network. **c** - Final automata with proposing an explicit representation of the implicit knowledge

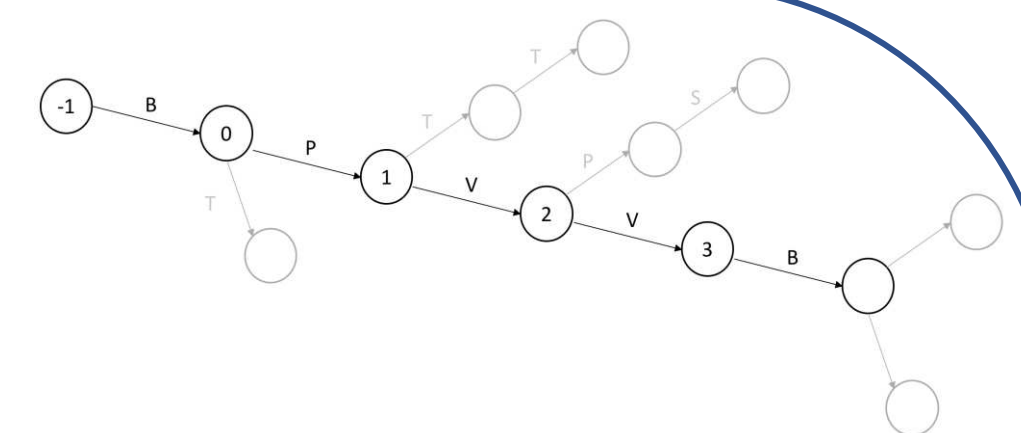

Fig.5: Testing process of the grammatical sequence BPVVE from RG

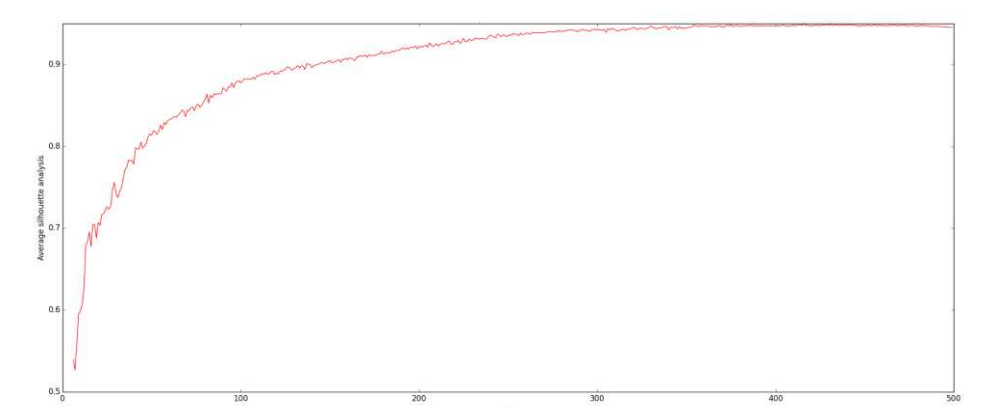

Fig.6: Evolution of the average silhouette score computed on 5000 HD in RG context for k in [6,500] used for generation of automata in fig.4

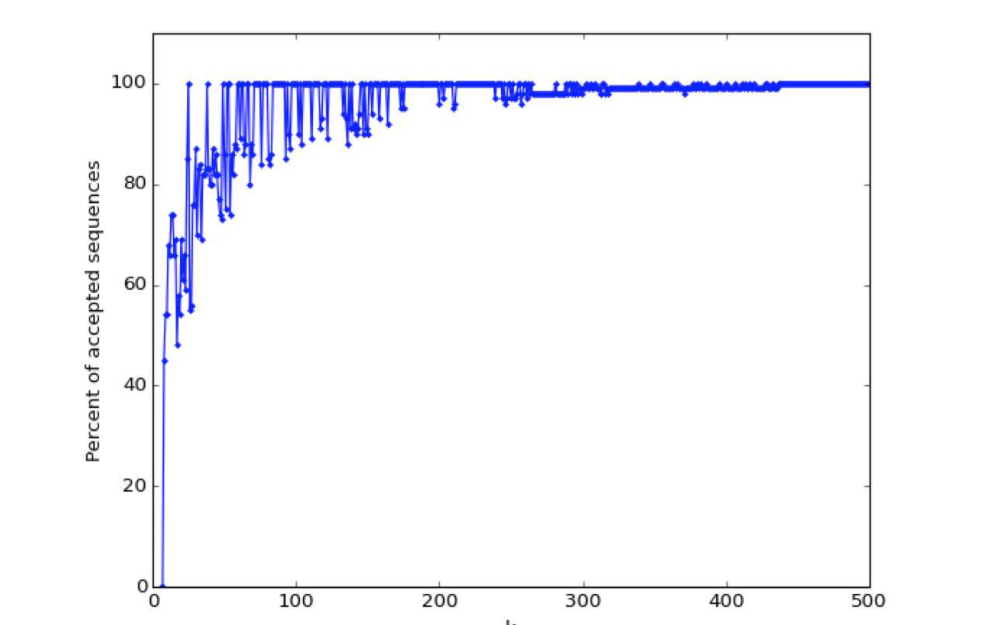

Fig.7: Percent of recognized sequences from RG. Analysis of extracted automata in fig.4

F – Perspectives

- During learning, the **network develops an implicit representation of the regularities**, i.e. rules of the artificial non-binary grammars. During testing, it can **predicts the output according to these implicit rules**. Results were confirmed in RG and ERG context
- Regarding the **question of neural networks interpretability**, it is possible to extract a representation in the form of graphs, with three different notation systems, each carrying **information on the internal functioning of the network** (explaining the prediction and behavior of the network)
- Preliminary results were obtained on real data extracted from electrical diagrams (Chraibi Kaadoud, 2018), and research is still in progress for a solid and general solution: simulations are ongoing on other artificial data, other real data, and different others grammars

References (1) Squire, Larry R et Zola, Stuart M, 1996. Structure and function of declarative and nondeclarative memory systems. Proceedings of the National Academy of Sciences, 93(24) :13515–13522.
(2) Kim, JongW, Ritter, Frank E et Koubek, Richard J, 2013. An integrated theory for improved skill acquisition and retention in the three stages of learning. Theoretical Issues in Ergonomics Science, 14(1) :22–37.
(3) Elman, Jeffrey L, 1990. Finding structure in time. Cognitive science, 14(2) :179–211.
(4) Cleeremans, A., McClelland, J.L.: Learning the structure of event sequences. Journal of Experimental Psychology: General 120(3), 235 (1991)
(5) Reber, Arthur S, 1967. Implicit learning of artificial grammars. Journal of verbal learning and verbal behavior, 6(6) :855–863.
(6) Gers, Felix A, Schmidhuber, Jürgen et Cummins, Fred, 1999. Learning to forget : Continual prediction with lstm.
(7) Chraibi Kaadoud, Ikram, 2018. "Sequence learning and rules extraction from recurrent neural networks : application to the drawing of technical diagrams." Theses. Université de Bordeaux, France