



**HAL**  
open science

## A fiber frequency-shifting loop for RF up-conversion and waveform generation

Haiyang Zhang, Hongzhi Yang, Marc Brunel, Marc Vallet, Changming Zhao,  
Suhui Yang

► **To cite this version:**

Haiyang Zhang, Hongzhi Yang, Marc Brunel, Marc Vallet, Changming Zhao, et al.. A fiber frequency-shifting loop for RF up-conversion and waveform generation. Journée du Club Optique et Micro-ondes (JCOM 2017), 2017, Limoges, France. hal-02470380

**HAL Id: hal-02470380**

**<https://hal.science/hal-02470380v1>**

Submitted on 12 Feb 2020

**HAL** is a multi-disciplinary open access archive for the deposit and dissemination of scientific research documents, whether they are published or not. The documents may come from teaching and research institutions in France or abroad, or from public or private research centers.

L'archive ouverte pluridisciplinaire **HAL**, est destinée au dépôt et à la diffusion de documents scientifiques de niveau recherche, publiés ou non, émanant des établissements d'enseignement et de recherche français ou étrangers, des laboratoires publics ou privés.

## Introduction

- ring interferometer + frequency-shifter + amplifier [1-4]  
=> self-heterodyning, Frequency-Shifted Feedback Laser, real-time Fourier Transform, wavelength scan, etc.
- microwave photonics context (lidar-radar for example) [5-8]  
=> RF up-conversion, waveform generation
- Here high-harmonic RF beats, sub-threshold operation ( $\neq$  FSF laser)  
+ all-fibered experiment @ 1064 nm vs simulation

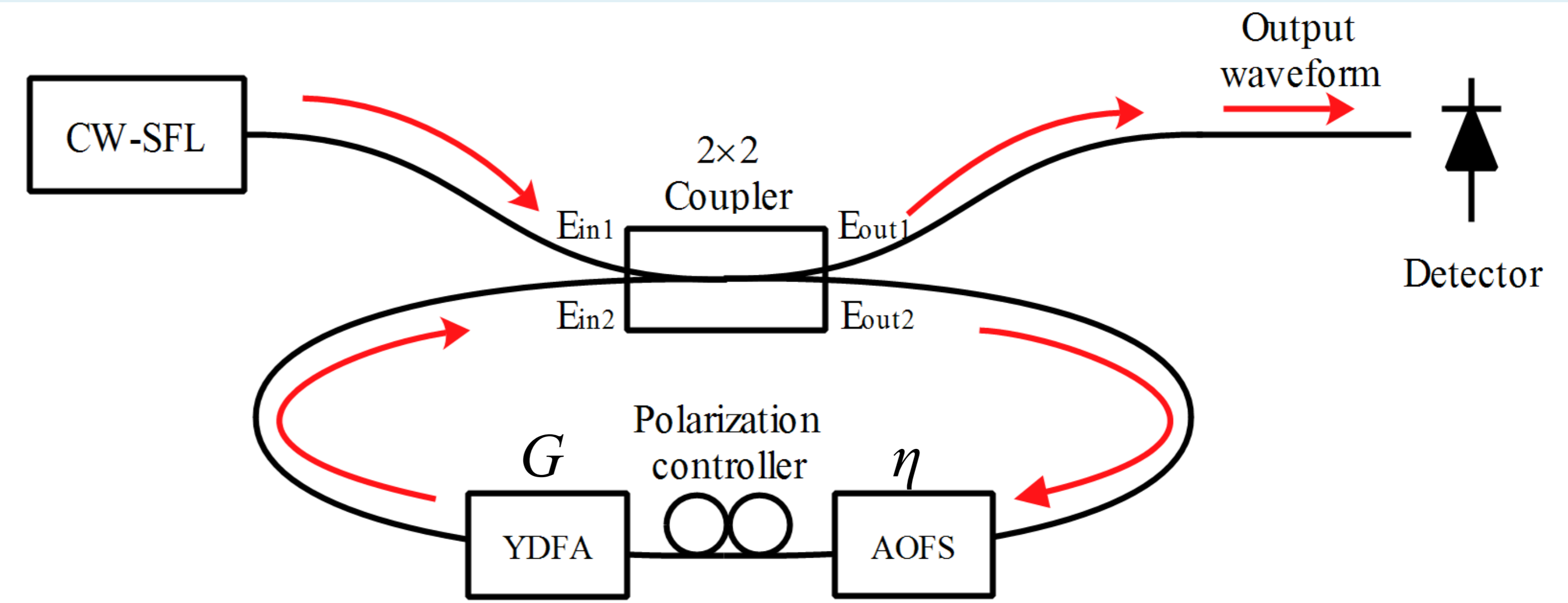

## Model: time delayed interferences

$$\begin{bmatrix} E_{out1} \\ E_{out2} \end{bmatrix} = \begin{bmatrix} t_{11} & t_{12} \\ t_{21} & t_{22} \end{bmatrix} \begin{bmatrix} E_{in1} \\ E_{in2} \end{bmatrix}$$

- $\lambda = 1064$  nm (YDFA with gain  $G$ )
- Acousto-Optic Frequency Shifter  
 $f_{AO} = 200$  MHz  $\pm$  5 MHz,  $\eta = 0,4$
- $\sim 20$  m loop ( $\tau = 5$  ns)

Inside the loop:

$$E_{out2}(t) = t_{21} \sum_{p=0}^{\infty} (t_{22}\gamma)^p E_{in1}(t-p\tau) e^{i2\pi f_{AO}p(t-\tau)} e^{-i\pi f_{AO}p^2\tau} \quad \text{with } \gamma = \sqrt{\eta G} e^{i\phi}$$

Output field:

$$\begin{aligned} E_{out1}(t) &= t_{11}E_{in1}(t) + t_{12}E_{in2}(t) \\ &= t_{11}E_{in1}(t) + t_{12}\gamma E_{out2}(t-\tau) e^{i2\pi f_{AO}(t-\tau)} \\ &= t_{11}E_{in1}(t) + t_{12}\gamma t_{21} \sum_{p=1}^{\infty} (t_{22}\gamma)^{(p-1)} E_{in1}(t-p\tau) e^{-i\pi f_{AO}p\tau} e^{i2\pi f_{AO}pt} e^{-i\pi f_{AO}p^2\tau} \end{aligned}$$

Output power:

$$P_{out}(t) = \left| t_{11} + t_{12}\gamma t_{21} \sum_{p=0}^{\infty} (t_{22}\gamma)^p e^{i2\pi f_{AO}(p+1)t} e^{-i\pi f_{AO}(p+2)(p+1)\tau} \right|^2 P_{in}$$

$$P_{out}(t) = P_0 + \sum_{n=1}^{\infty} \left[ P_n e^{i2\pi n f_{AO} t} + cc \right] \quad \text{with } |P_n| = (\Gamma T_{11})^{n/2} T_{12} \sqrt{\frac{(1-\Gamma)^2 + 4\Gamma \sin^2(n\pi f_{AO}\tau)}{(1-\Gamma T_{11})^2 + 4\Gamma T_{11} \sin^2(n\pi f_{AO}\tau)}} \\ \Gamma = |\gamma|^2$$

## Frequency domain: harmonics vs gain

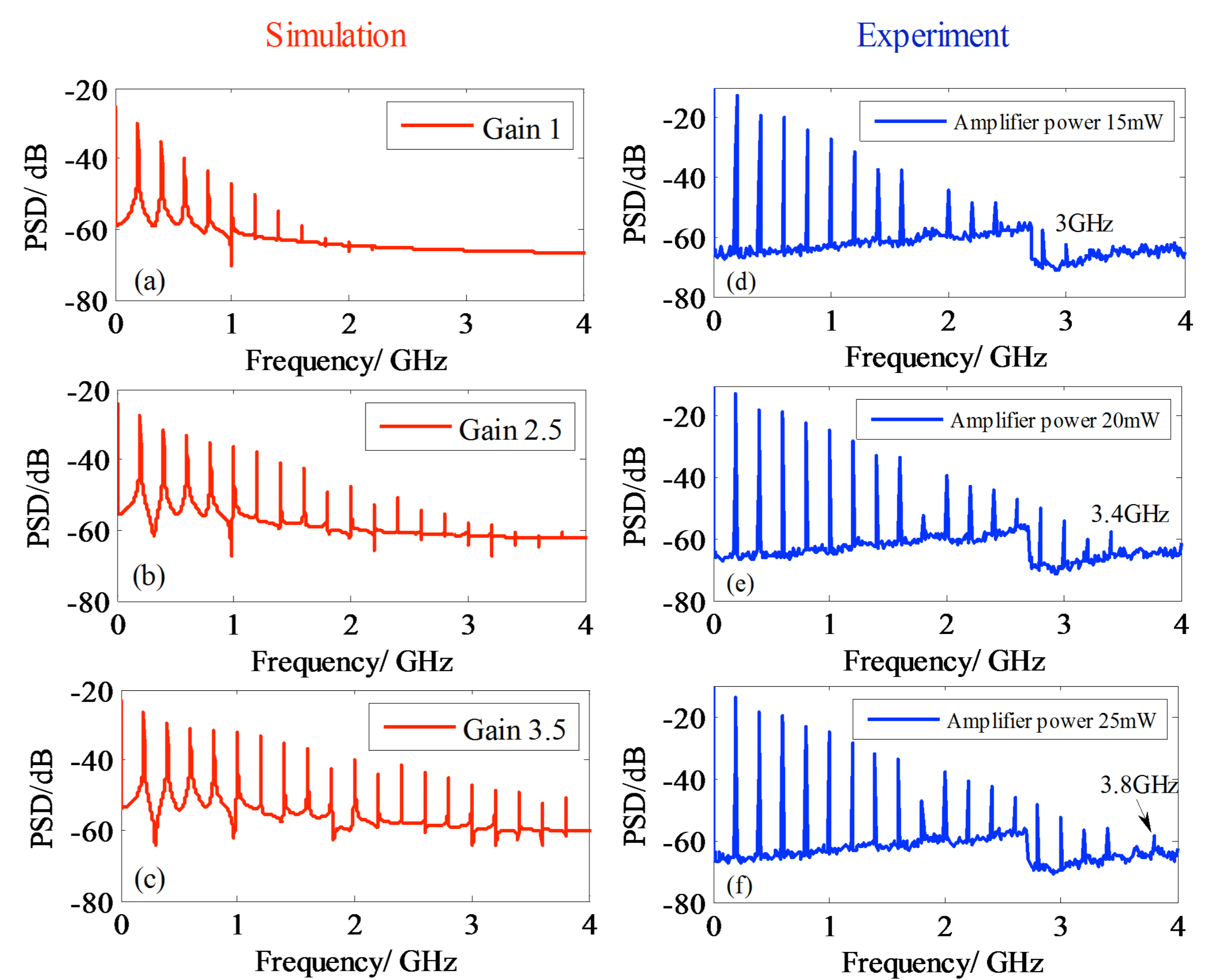

Harmonics  
Linewidth:

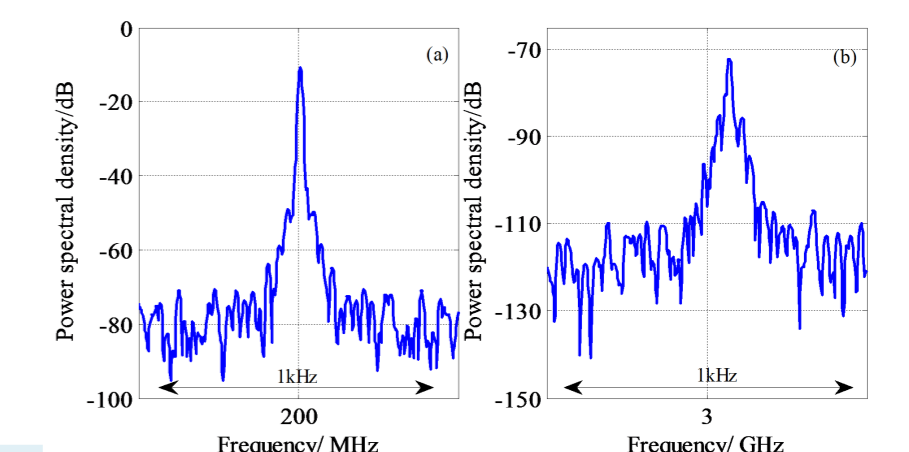

## Time domain: waveform depends on the RF harmonics phases ( $n\pi f_{AO}\tau$ )

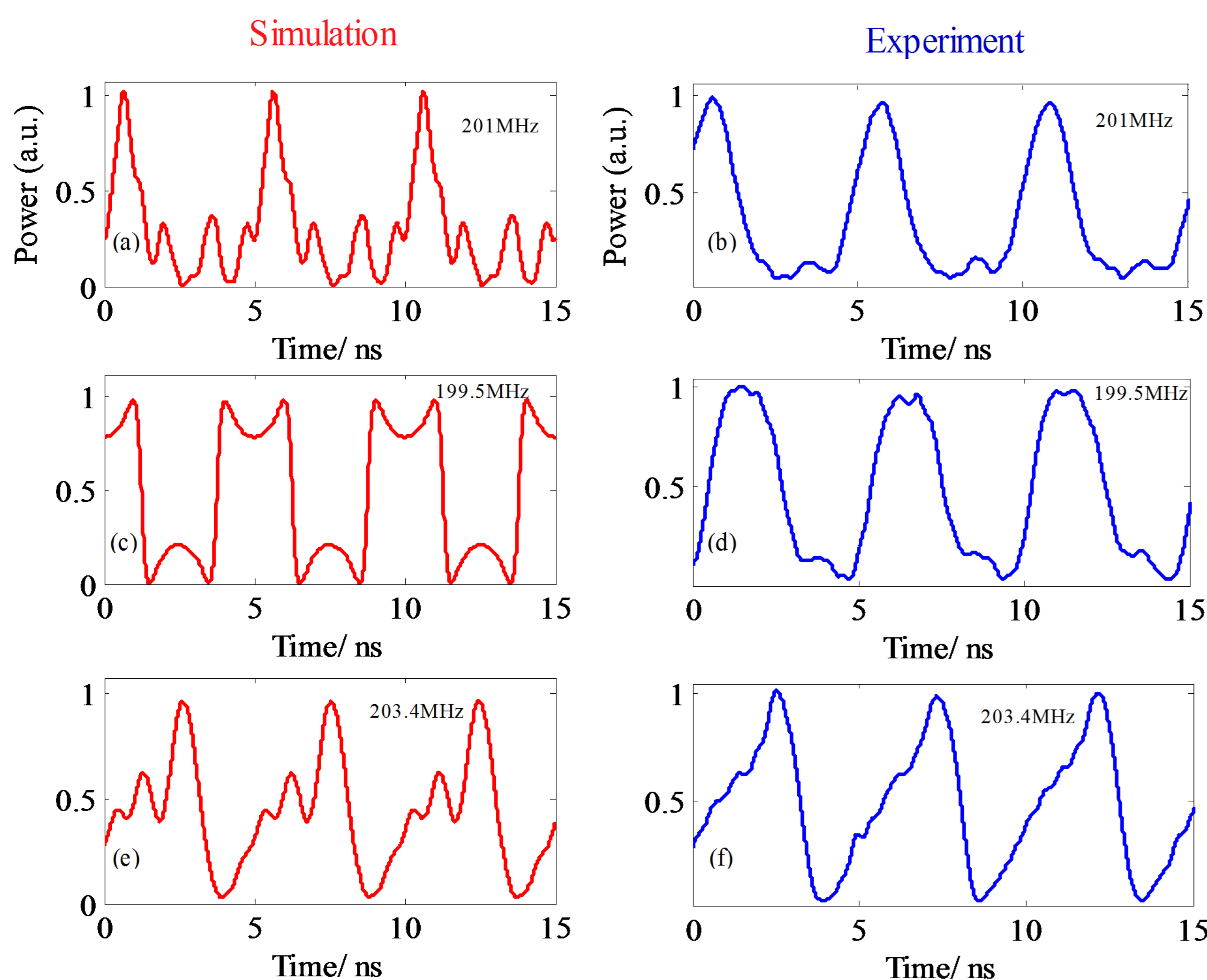

Influence of frequency shift on the waveform

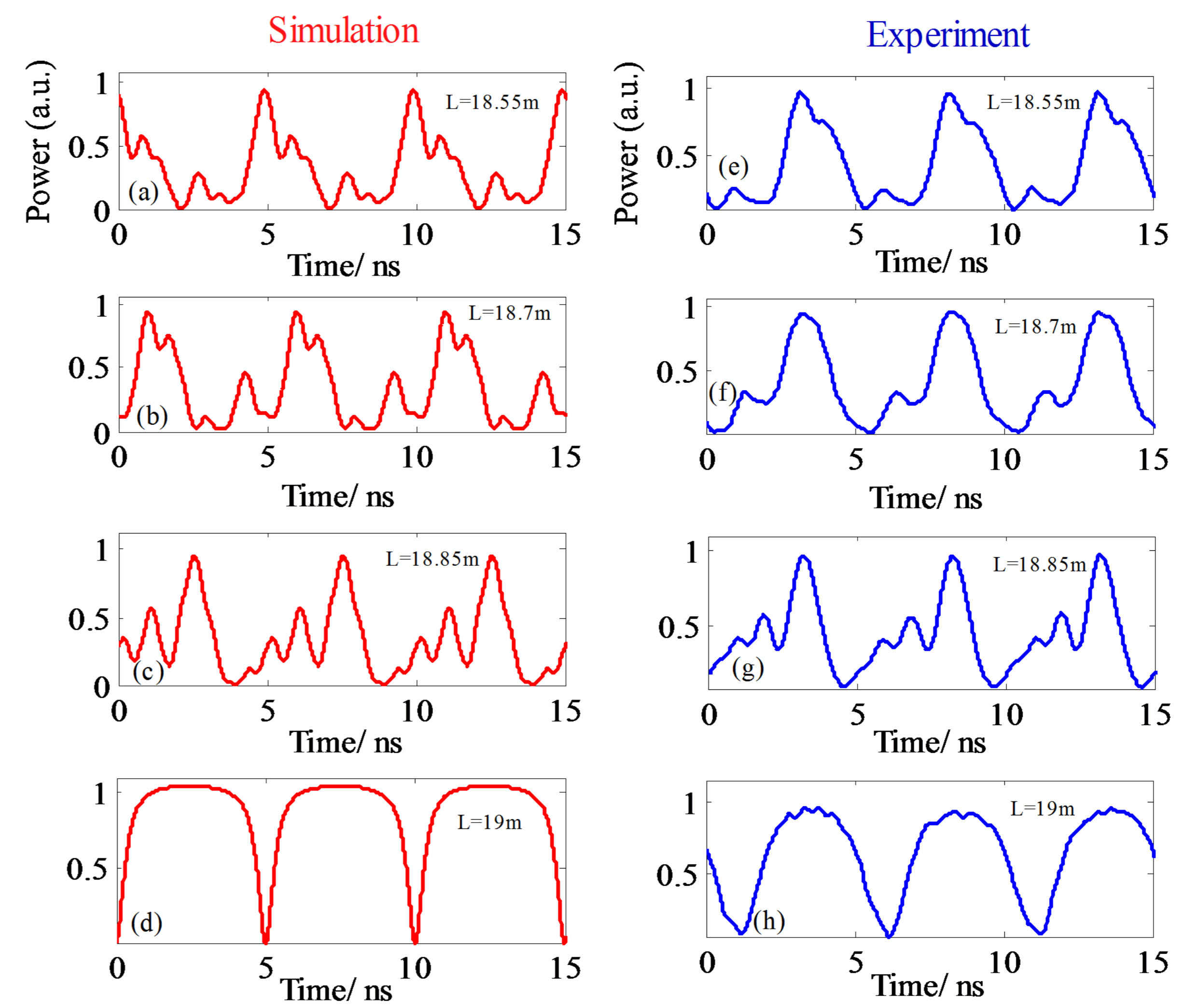

Influence of the loop length on the waveform (steps of 15 cm)

## Conclusion

- RF enhancement x15 (here up to  $\sim 4$  GHz)
- programmable and integrable scheme
- Perspectives*
- + SHG => green source for underwater [5-6]
- Ultra-low Doppler frequency shifts
- All-fibered experiment @ 1550 nm
- Above threshold (solitons, mode-locking, etc)

## References

- [1] J. W. Dawson, N. Park, K. J. Vahala, IEEE Photon. Technol. Lett. **4**, 1063 (1992).
- [2] H. Sabert, E. Brinkmeyer, J. Lightwave Technol. **12**, 1360 (1994).
- [3] H. Guillet de Chatellus, L. R. Cortés, and J. Azaña, Optica **3**, 1 (2016).
- [4] M. Wan *et al.*, Opt. Exp. **24**, 27614 (2016).
- [5] H. Zhang, M. Brunel, M. Romanelli, and M. Vallet, Appl. Opt. **55**, 2467 (2016).
- [6] B. Cochenour, L. Mullen, and J. Muth, Appl. Opt. **50**, 6168 (2011).
- [7] M. Vallet *et al.*, Appl. Opt. **52**, 5402 (2013)
- [8] Z. Zheng *et al.*, Opt. Laser Technol. **80**, 169 (2016)