



HAL
open science

Families of solutions to the CKP equation with multi-parameters

Pierre Gaillard

► **To cite this version:**

Pierre Gaillard. Families of solutions to the CKP equation with multi-parameters. 2020. hal-02427660

HAL Id: hal-02427660

<https://hal.science/hal-02427660v1>

Preprint submitted on 3 Jan 2020

HAL is a multi-disciplinary open access archive for the deposit and dissemination of scientific research documents, whether they are published or not. The documents may come from teaching and research institutions in France or abroad, or from public or private research centers.

L'archive ouverte pluridisciplinaire **HAL**, est destinée au dépôt et à la diffusion de documents scientifiques de niveau recherche, publiés ou non, émanant des établissements d'enseignement et de recherche français ou étrangers, des laboratoires publics ou privés.

Families of solutions to the CKP equation with multi-parameters

Pierre Gaillard

Université de Bourgogne,
Institut de mathématiques de Bourgogne,
9 avenue Alain Savary BP 47870
21078 Dijon Cedex, France :

E-mail: Pierre.Gaillard@u-bourgogne.fr

Abstract. We construct solutions to the CKP (cylindrical Kadomtsev-Petviashvili) equation in terms of Fredholm determinants. We deduce solutions written as a quotient of wronskians of order $2N$. These solutions are called solutions of order N ; they depend on $2N - 1$ parameters. They can be written as a quotient of 2 polynomials of degree $2N(N + 1)$ in x, t and $4N(N + 1)$ in y depending on $2N - 2$ parameters.

We explicitly construct the expressions up to order 5 and we study the patterns of their modulus in plane (x, y) and their evolution according to time and parameters.

Keywords : Fredholm determinants, wronskians, rational solutions, CKP equation.

PACS numbers :

33Q55, 37K10, 47.10A-, 47.35.Fg, 47.54.Bd

1. Introduction

We consider the CKP equation which can be written in the form

$$(u_t + 6uu_x + u_{xxx} + \frac{u}{2t})_x - 3\frac{u_{yy}}{t^2} = 0, \quad (1)$$

subscripts x, y and t denoting partial derivatives.

Johnson [1] first proposed this equation in 1980. That equation is considered to describe wave surfaces in shallow incompressible fluids [2, 3]. This equation was later derived for internal waves in a stratified medium [4]. The CKP equation is a dissipative equation. There is no soliton-like solution with a linear front localized along straight lines in the (x, y) plane.

The first solutions were constructed by Johnson in 1980 [1]. Other types of solutions were found by Golinko, Dryuma, and Stepanyants in 1984 [5]. This equation was solved with a new approach in 1986 [6] by giving a connection between solutions of the Kadomtsev-Petviashvili (KP) [7] and solutions of the CKP equation. The Darboux transformation [8] gave another types of solutions. In 2013, the extension to the elliptic case was considered [9].

In the following, we give the results of the author about the representations of solutions to the CKP equation. We have expressed the solutions in terms of Fredholm determinants of order

$2N$ depending on $2N - 1$ parameters. We have also given another representation in terms of wronskians of order $2N$ with $2N - 1$ parameters. These representations allow to obtain an infinite hierarchy of solutions to the CKP equation, depending on $2N - 1$ real parameters. We have used these results to build rational solutions to the CKP equation, when a parameter tends to 0.

Rational solutions of order N depending on $2N - 2$ parameters without the presence of a limit have been constructed. These families depending on $2N - 2$ parameters for the N -th order can be written as a ratio of two polynomials of degree $2N(N + 1)$ in x, t and $4N(N + 1)$ in y depending on $2N - 2$ parameters.

That provides an effective method to build an infinite hierarchy of rational solutions of order N depending on $2N - 2$ real parameters. We present here the representations of their modulus in the plane of the coordinates (x, y) and their evolution according to time and the $2N - 2$ real parameters a_i and b_i and time t for N an integer such that $1 \leq N \leq 5$.

2. Solutions to the CKP equation expressed in terms of Fredholm determinants

We need to give some notation in the following. We define first real numbers λ_j such that $-1 < \lambda_\nu < 1$, $\nu = 1, \dots, 2N$; they depend on a parameter ϵ and can be written as

$$\lambda_j = 1 - 2\epsilon^2 j^2, \quad \lambda_{N+j} = -\lambda_j, \quad 1 \leq j \leq N, \quad (2)$$

Then, we define $\kappa_\nu, \delta_\nu, \gamma_\nu$ and $x_{r,\nu}$; they are functions of λ_ν , $1 \leq \nu \leq 2N$ and are defined by the following formulas :

$$\begin{aligned} \kappa_j &= 2\sqrt{1 - \lambda_j^2}, & \delta_j &= \kappa_j \lambda_j, & \gamma_j &= \sqrt{\frac{1 - \lambda_j}{1 + \lambda_j}}; \\ x_{r,j} &= (r - 1) \ln \frac{\gamma_j - i}{\gamma_j + i}, & r &= 1, 3, & \tau_j &= -12i\lambda_j^2 \sqrt{1 - \lambda_j^2} - 4i(1 - \lambda_j^2) \sqrt{1 - \lambda_j^2}, \\ \kappa_{N+j} &= \kappa_j, & \delta_{N+j} &= -\delta_j, & \gamma_{N+j} &= \gamma_j^{-1}, \\ x_{r,N+j} &= -x_{r,j}, & \tau_{N+j} &= \tau_j & j &= 1, \dots, N. \end{aligned} \quad (3)$$

e_ν $1 \leq \nu \leq 2N$ are defined by :

$$\begin{aligned} e_j &= 2i \left(\sum_{k=1}^{1/2 M-1} a_k (je)^{2k+1} - i \sum_{k=1}^{1/2 M-1} b_k (je)^{2k+1} \right), \\ e_{N+j} &= 2i \left(\sum_{k=1}^{1/2 M-1} a_k (je)^{2k+1} + i \sum_{k=1}^{1/2 M-1} b_k (je)^{2k+1} \right), \quad 1 \leq j \leq N, \\ a_k, b_k &\in \mathbf{R}, \quad 1 \leq k \leq N. \end{aligned} \quad (4)$$

ϵ_ν , $1 \leq \nu \leq 2N$ are defined by :

$$\epsilon_j = 1, \quad \epsilon_{N+j} = 0 \quad 1 \leq j \leq N. \quad (5)$$

As usual I is the unit matrix and $D_r = (d_{jk})_{1 \leq j, k \leq 2N}$ the matrix defined by :

$$d_{\nu\mu} = (-1)^{\epsilon_\nu} \prod_{\eta \neq \mu} \left(\frac{\gamma_\eta + \gamma_\nu}{\gamma_\eta - \gamma_\mu} \right) \exp(\kappa_\nu x + (\frac{\kappa_\nu y}{12} - 2\delta_\nu)yt + 4i\tau_\nu t + x_{r,\nu} + e_\nu). \quad (6)$$

Then we get :

Theorem 2.1 *The function v defined by*

$$v(x, y, t) = -2 \frac{|n(x, y, t)|^2}{d(x, y, t)^2} \quad (7)$$

where

$$n(x, y, t) = \det(I + D_3(x, y, t)), \quad (8)$$

$$d(x, y, t) = \det(I + D_1(x, y, t)), \quad (9)$$

and $D_r = (d_{jk})_{1 \leq j, k \leq 2N}$ the matrix

$$d_{\nu\mu} = (-1)^{\epsilon_\nu} \prod_{\eta \neq \mu} \left(\frac{\gamma_\eta + \gamma_\nu}{\gamma_\eta - \gamma_\mu} \right) \exp(\kappa_\nu x + (\frac{\kappa_\nu y}{12} - 2\delta_\nu)yt + 4i\tau_\nu t + x_{r,\nu} + e_\nu). \quad (10)$$

is a solution to (1), depending on $2N - 1$ parameters $a_k, b_k, 1 \leq k \leq N - 1$ and ϵ .

A proof of this result is a consequence of previous works of the author [18, 20, 36, 43].

3. Wronskian representation of the solutions to the CKP equation

We define here the following notations :

$$\phi_{r,\nu} = \sin \Theta_{r,\nu}, \quad 1 \leq \nu \leq N, \quad \phi_{r,\nu} = \cos \Theta_{r,\nu}, \quad N + 1 \leq \nu \leq 2N, \quad r = 1, 3, \quad (11)$$

with

$$\Theta_{r,\nu} = \frac{-i\kappa_\nu x}{2} + i(\frac{-\kappa_\nu y}{24} + \delta_\nu)yt - i\frac{x_{r,\nu}}{2} + 2\tau_\nu t + \gamma_\nu w - i\frac{e_\nu}{2}, \quad 1 \leq \nu \leq 2N. \quad (12)$$

$W_r(w)$ is the wronskian of the functions $\phi_{r,1}, \dots, \phi_{r,2N}$ defined by

$$W_r(w) = \det[(\partial_w^{\mu-1} \phi_{r,\nu})_{\nu, \mu \in [1, \dots, 2N]}]. \quad (13)$$

We consider the matrix $D_r = (d_{\nu\mu})_{\nu, \mu \in [1, \dots, 2N]}$ defined in (10).

Then we have the following result

Theorem 3.1

$$\det(I + D_r) = k_r(0) \times W_r(\phi_{r,1}, \dots, \phi_{r,2N})(0), \quad (14)$$

where

$$k_r(y) = \frac{2^{2N} \exp(i \sum_{\nu=1}^{2N} \Theta_{r,\nu})}{\prod_{\nu=2}^{2N} \prod_{\mu=1}^{\nu-1} (\gamma_\nu - \gamma_\mu)}.$$

It is also a consequence of previous works of the author [18, 20, 36, 43].

4. Rational solutions to the CKP equation

From those two preceding results, we can construct rational solutions to the CKP equation as a quotient of two determinants.

We use the following notations :

$$X_\nu = \frac{-i\kappa_\nu x}{2} + i(\frac{-\kappa_\nu y}{24} + \delta_\nu)yt - i\frac{x_{3,\nu}}{2} + 2\tau_\nu t + \gamma_\nu w - i\frac{e_\nu}{2},$$

$$Y_\nu = \frac{-i\kappa_\nu x}{2} + i(\frac{-\kappa_\nu y}{24} + \delta_\nu)yt - i\frac{x_{1,\nu}}{2} + 2\tau_\nu t + \gamma_\nu w - i\frac{e_\nu}{2},$$

for $1 \leq \nu \leq 2N$, with $\kappa_\nu, \delta_\nu, x_{r,\nu}$ defined in (3) and parameters e_ν defined by (4). We define the following functions :

$$\begin{aligned}\varphi_{4j+1,k} &= \gamma_k^{4j-1} \sin X_k, & \varphi_{4j+2,k} &= \gamma_k^{4j} \cos X_k, \\ \varphi_{4j+3,k} &= -\gamma_k^{4j+1} \sin X_k, & \varphi_{4j+4,k} &= -\gamma_k^{4j+2} \cos X_k,\end{aligned}\tag{15}$$

for $1 \leq k \leq N$, and

$$\begin{aligned}\varphi_{4j+1,N+k} &= \gamma_k^{2N-4j-2} \cos X_{N+k}, & \varphi_{4j+2,N+k} &= -\gamma_k^{2N-4j-3} \sin X_{N+k}, \\ \varphi_{4j+3,N+k} &= -\gamma_k^{2N-4j-4} \cos X_{N+k}, & \varphi_{4j+4,N+k} &= \gamma_k^{2N-4j-5} \sin X_{N+k},\end{aligned}\tag{16}$$

for $1 \leq k \leq N$.

We define the functions $\psi_{j,k}$ for $1 \leq j \leq 2N, 1 \leq k \leq 2N$ in the same way, the term X_k is only replaced by Y_k .

$$\begin{aligned}\psi_{4j+1,k} &= \gamma_k^{4j-1} \sin Y_k, & \psi_{4j+2,k} &= \gamma_k^{4j} \cos Y_k, \\ \psi_{4j+3,k} &= -\gamma_k^{4j+1} \sin Y_k, & \psi_{4j+4,k} &= -\gamma_k^{4j+2} \cos Y_k,\end{aligned}\tag{17}$$

for $1 \leq k \leq N$, and

$$\begin{aligned}\psi_{4j+1,N+k} &= \gamma_k^{2N-4j-2} \cos Y_{N+k}, & \psi_{4j+2,N+k} &= -\gamma_k^{2N-4j-3} \sin Y_{N+k}, \\ \psi_{4j+3,N+k} &= -\gamma_k^{2N-4j-4} \cos Y_{N+k}, & \psi_{4j+4,N+k} &= \gamma_k^{2N-4j-5} \sin Y_{N+k},\end{aligned}\tag{18}$$

for $1 \leq k \leq N$.

The following ratio

$$q(x, t) := \frac{W_3(0)}{W_1(0)}$$

can be written as

$$q(x, t) = \frac{\Delta_3}{\Delta_1} = \frac{\det(\varphi_{j,k})_{j,k \in [1,2N]}}{\det(\psi_{j,k})_{j,k \in [1,2N]}}.\tag{19}$$

The terms λ_j depending on ϵ are defined by $\lambda_j = 1 - 2j\epsilon^2$. All the functions $\varphi_{j,k}$ and $\psi_{j,k}$ and their derivatives depend on ϵ . They can all be prolonged by continuity when $\epsilon = 0$.

We use the following expansions

$$\varphi_{j,k}(x, y, t, \epsilon) = \sum_{l=0}^{N-1} \frac{1}{(2l)!} \varphi_{j,1}[l] k^{2l} \epsilon^{2l} + O(\epsilon^{2N}), \quad \varphi_{j,1}[l] = \frac{\partial^{2l} \varphi_{j,1}}{\partial \epsilon^{2l}}(x, y, t, 0),$$

$$\varphi_{j,1}[0] = \varphi_{j,1}(x, y, t, 0), \quad 1 \leq j \leq 2N, \quad 1 \leq k \leq N, \quad 1 \leq l \leq N-1,$$

$$\varphi_{j,N+k}(x, y, t, \epsilon) = \sum_{l=0}^{N-1} \frac{1}{(2l)!} \varphi_{j,N+1}[l] k^{2l} \epsilon^{2l} + O(\epsilon^{2N}), \quad \varphi_{j,N+1}[l] = \frac{\partial^{2l} \varphi_{j,N+1}}{\partial \epsilon^{2l}}(x, y, t, 0),$$

$$\varphi_{j,N+1}[0] = \varphi_{j,N+1}(x, y, t, 0), \quad 1 \leq j \leq 2N, \quad 1 \leq k \leq N, \quad 1 \leq l \leq N-1.$$

We have the same expansions for the functions $\psi_{j,k}$.

$$\psi_{j,k}(x, y, t, \epsilon) = \sum_{l=0}^{N-1} \frac{1}{(2l)!} \psi_{j,1}[l] k^{2l} \epsilon^{2l} + O(\epsilon^{2N}), \quad \psi_{j,1}[l] = \frac{\partial^{2l} \psi_{j,1}}{\partial \epsilon^{2l}}(x, y, t, 0),$$

$$\psi_{j,1}[0] = \psi_{j,1}(x, y, t, 0), \quad 1 \leq j \leq 2N, \quad 1 \leq k \leq N, \quad 1 \leq l \leq N-1,$$

$$\psi_{j,N+k}(x, t, \epsilon) = \sum_{l=0}^{N-1} \frac{1}{(2l)!} \psi_{j,N+1}[l] k^{2l} \epsilon^{2l} + O(\epsilon^{2N}), \quad \psi_{j,N+1}[l] = \frac{\partial^{2l} \psi_{j,N+1}}{\partial \epsilon^{2l}}(x, y, t, 0),$$

$$\psi_{j,N+1}[0] = \psi_{j,N+1}(x, t, 0), \quad 1 \leq j \leq 2N, \quad 1 \leq k \leq N, \quad N+1 \leq k \leq 2N..$$

Then we get the following result :

Theorem 4.1 *The function v defined by*

$$v(x, y, t) = -2 \frac{|\det((n_{jk})_{j,k \in [1,2N]})|^2}{\det((d_{jk})_{j,k \in [1,2N]})^2} \quad (20)$$

is a rational solution to the CKP equation (1), where

$$\begin{aligned} n_{j1} &= \varphi_{j,1}(x, y, t, 0), \quad 1 \leq j \leq 2N & n_{jk} &= \frac{\partial^{2k-2} \varphi_{j,1}}{\partial \epsilon^{2k-2}}(x, y, t, 0), \\ n_{jN+1} &= \varphi_{j,N+1}(x, y, t, 0), \quad 1 \leq j \leq 2N & n_{jN+k} &= \frac{\partial^{2k-2} \varphi_{j,N+1}}{\partial \epsilon^{2k-2}}(x, y, t, 0), \\ d_{j1} &= \psi_{j,1}(x, y, t, 0), \quad 1 \leq j \leq 2N & d_{jk} &= \frac{\partial^{2k-2} \psi_{j,1}}{\partial \epsilon^{2k-2}}(x, y, t, 0), \\ d_{jN+1} &= \psi_{j,N+1}(x, y, t, 0), \quad 1 \leq j \leq 2N & d_{jN+k} &= \frac{\partial^{2k-2} \psi_{j,N+1}}{\partial \epsilon^{2k-2}}(x, y, t, 0), \\ & & & 2 \leq k \leq N, \quad 1 \leq j \leq 2N \end{aligned} \quad (21)$$

The functions φ and ψ are defined in (15), (16), (17), (18).

5. Study of the patterns of the modulus of the rational solutions to the CKP equation in function of parameters and time

We have explicitly constructed rational solutions to the CKP equation of order N depending on $2N-2$ parameters for $1 \leq N \leq 5$.

In the following, we only give patterns of the modulus of the solutions in the plane (x, y) of coordinates in function of the parameters a_i , and b_i , for $1 \leq i \leq N-1$ for $2 \leq N \leq 5$, and time t .

5.1. Case $N = 1$

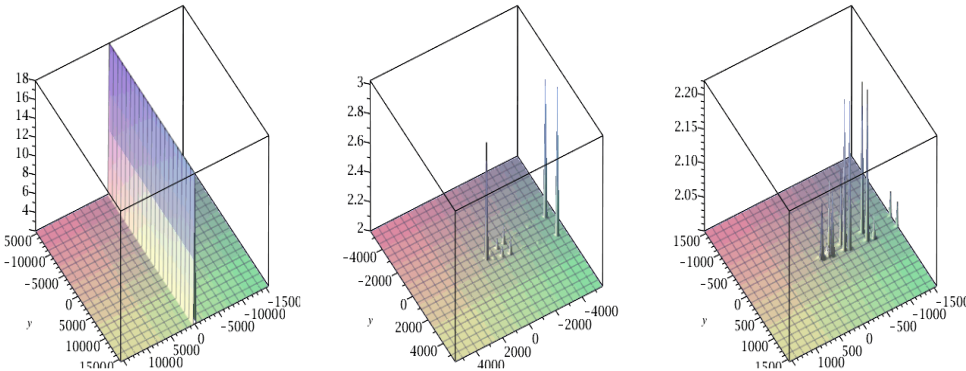

Figure 1. Solution of order 1 to (1), on the left for $t = 0$; in the center for $t = 0$; on the right for $t = 1$.

5.2. Case $N = 2$

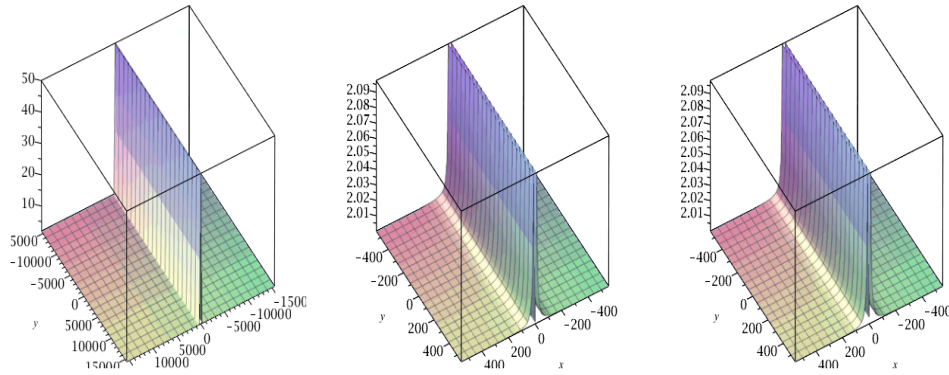

Figure 2. Solution of order 2 to (1) for $t = 0$, on the left $a_1 = 0, b_1 = 0$; in the center $a_1 = 100, b_1 = 0$; on the right $a_1 = 0, b_1 = 100$.

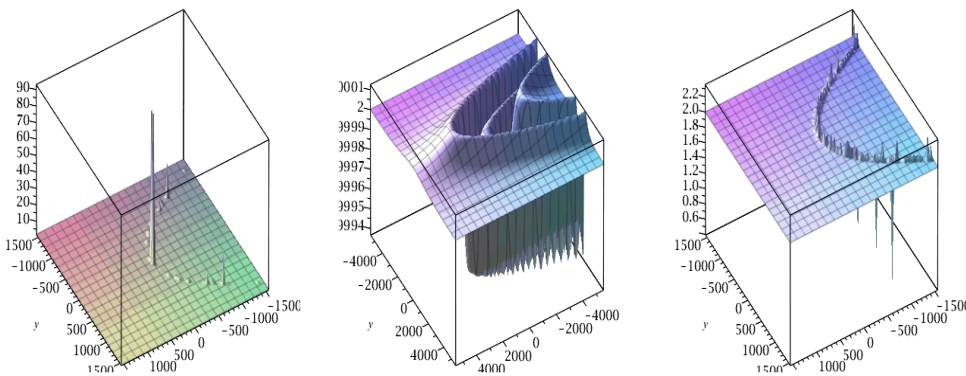

Figure 3. Solution of order 2 to (1) for $t = 0, 0.1$, on the left $a_1 = 0, b_1 = 0$; in the center $a_1 = 10, b_1 = 0$; on the right $a_1 = 10^2, b_1 = 0$.

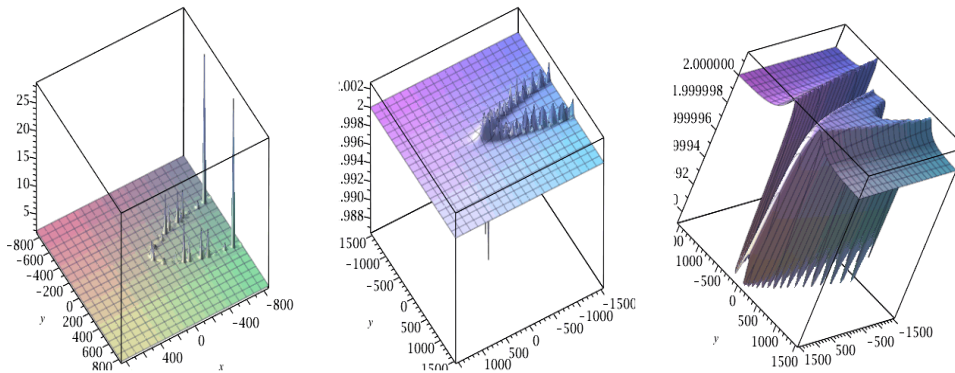

Figure 4. Solution of order 2 to (1) for $t = 0, 1$; on the left $a_1 = 0, b_1 = 0$; in the center $a_1 = 10^3, b_1 = 0$; on the right $a_1 = 10^3, b_1 = 10^3$.

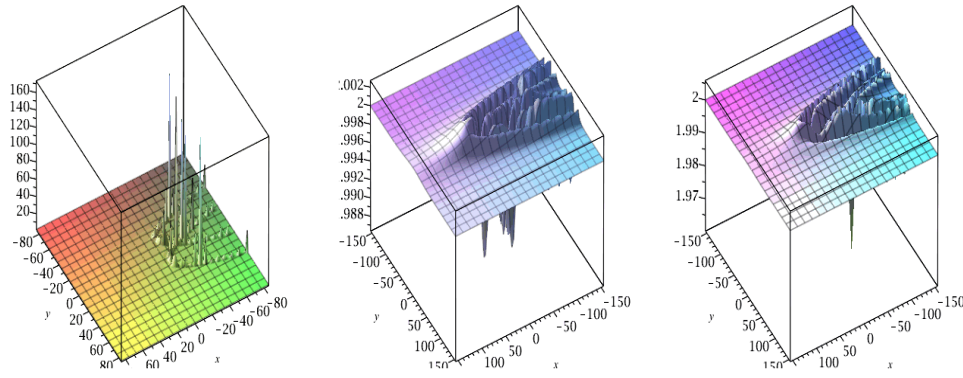

Figure 5. Solution of order 2 to (1) for $t = 1$; on the left $a_1 = 10$, $b_1 = 0$; in the center $a_1 = 10^5$, $b_1 = 0$; on the right $a_1 = 10^5$, $b_1 = 10^5$.

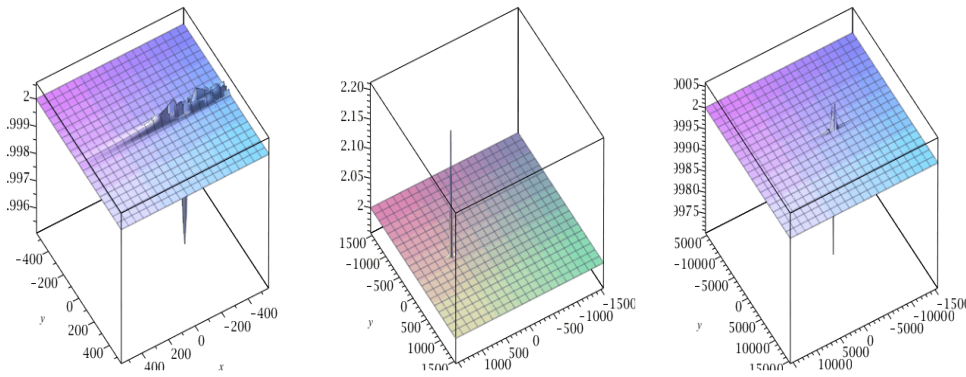

Figure 6. Solution of order 2 to (1); on the left for $t = 10$, $a_1 = 10^2$, $b_1 = 0$; in the center for $t = 100$, $a_1 = 10^3$, $b_1 = 0$; on the right for $t = 100$, $a_1 = 10^3$, $b_1 = 10^3$.

5.3. Case $N = 3$

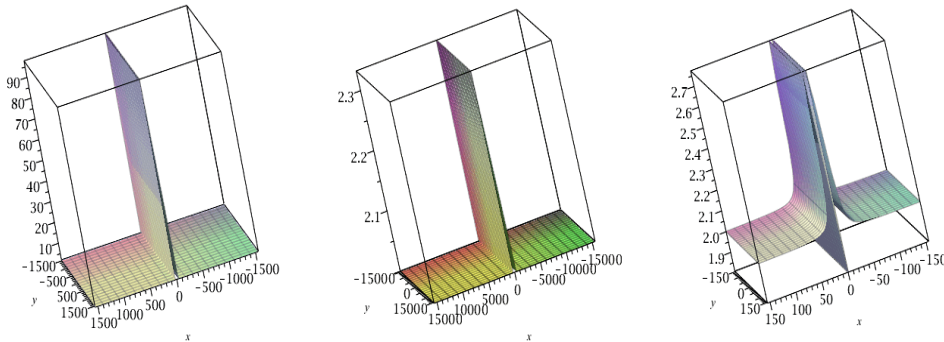

Figure 7. Solution of order 3 to (1), on the left for $t = 0$, $a_1 = 0$, $b_1 = 0$, $a_2 = 0$, $b_2 = 0$; in the center for $t = 0$, $a_1 = 1$, $b_1 = 0$, $a_2 = 0$, $b_2 = 0$; on the right for $t = 0$, $a_1 = 10$, $b_1 = 0$, $a_2 = 0$, $b_2 = 0$.

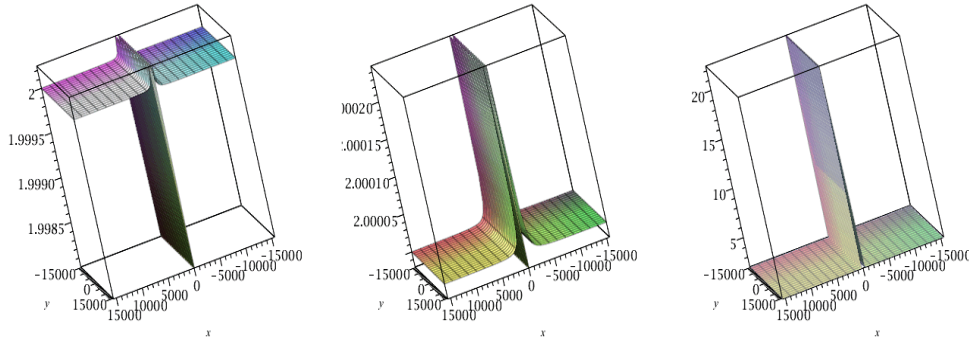

Figure 8. Solution of order 3 to (1), on the left for $t = 0$, $a_1 = 10^2$, $b_1 = 0$, $a_2 = 0$, $b_2 = 0$; in the center for $t = 0$, $a_1 = 10^3$, $b_1 = 0$, $a_2 = 0$, $b_2 = 0$; on the right for for $t = 0$, $a_1 = 10^5$, $b_1 = 0$, $a_2 = 0$, $b_2 = 0$.

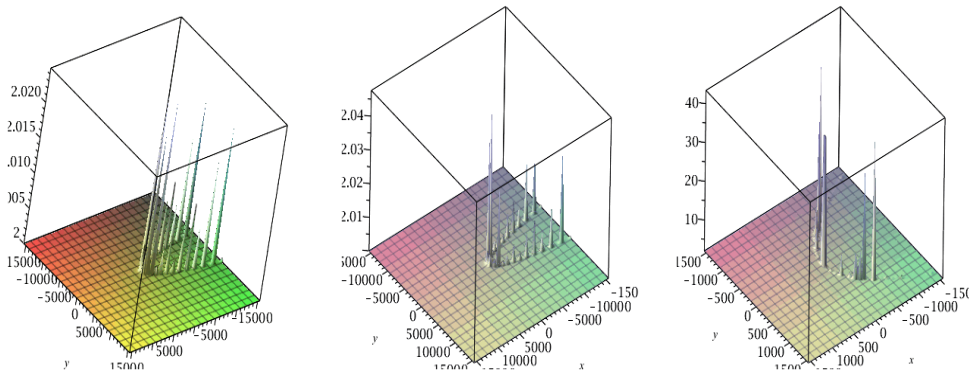

Figure 9. Solution of order 3 to (1), on the left for $t = 0,01$, $a_1 = 10^3$, $b_1 = 0$, $a_2 = 0$, $b_2 = 0$, ; in the center for $t = 0,01$, $a_1 = 0$, $b_1 = 10^3$, $a_2 = 0$, $b_2 = 0$; on the right for for $t = 0,01$, $a_1 = 0$, $b_1 = 0$, $a_2 = 10^8$, $b_2 = 0$.

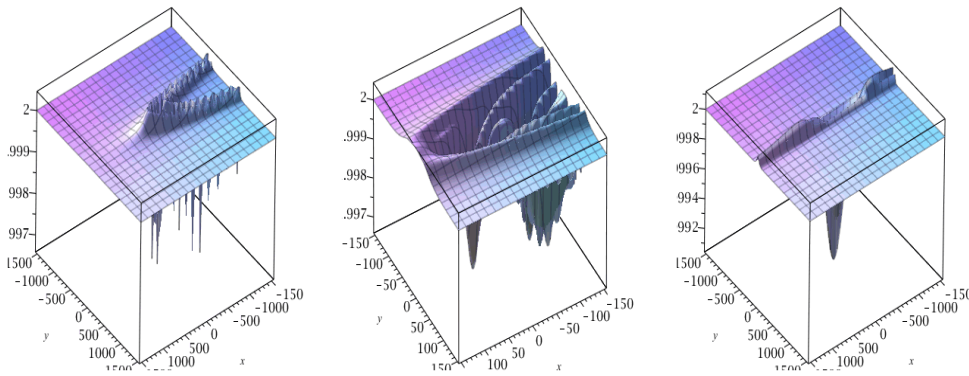

Figure 10. Solution of order 3 to (1), on the left for $t = 0,1$, $a_1 = 0$, $b_1 = 0$, $a_2 = 10^6$, $b_2 = 0$, ; in the center for $t = 1$, $a_1 = 0$, $b_1 = 0$, $a_2 = 10^6$, $b_2 = 0$; on the right for for $t = 10$, $a_1 = 10^3$, $b_1 = 0$, $a_2 = 0$, $b_2 = 0$.

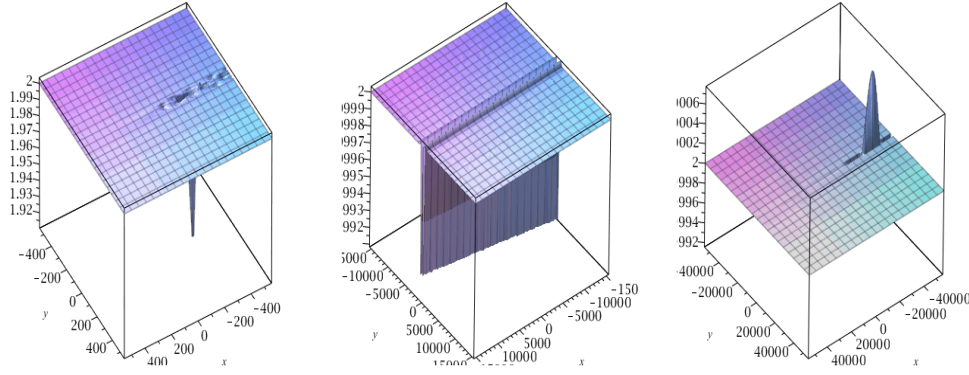

Figure 11. Solution of order 3 to (1), on the left for $t = 10$, $a_1 = 0$, $b_1 = 0$, $a_2 = 10^6$, $b_2 = 0$, ; in the center for $t = 100$, $a_1 = 10^6$, $b_1 = 0$, $a_2 = 0$, $b_2 = 0$; on the right for for $t = 10^3$, $a_1 = 10^5$, $b_1 = 10^3$, $a_2 = 0$, $b_2 = 0$.

The variation of the configuration of the modulus of the solutions is very fast according to time t . When time t grows from 0 to 0,01, one passes from a rectilinear structure with a height of 98 to a horseshoe structure with a maximum height equal to 4. The role played by the parameters a_i and b_i is the same one for same index i .

5.4. Case $N = 4$

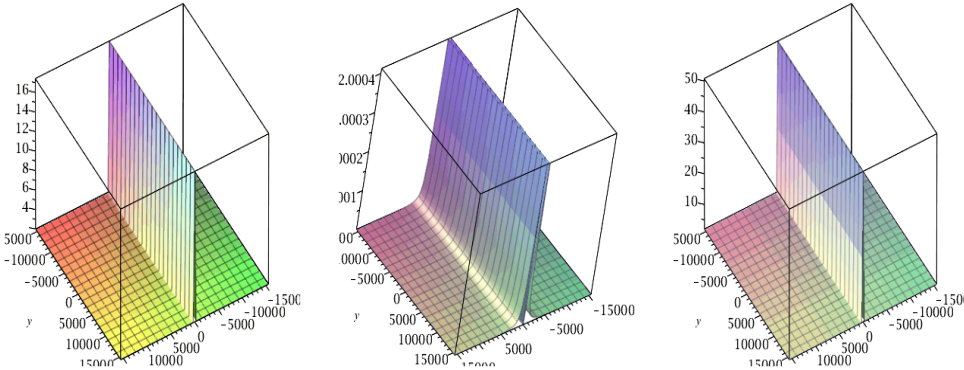

Figure 12. Solution of order 4 to (1), on the left for $t = 0$, $a_1 = 10$; in the center for $t = 0$, $a_2 = 10^4$; on the right for $t = 0$, $a_1 = 10$; all other parameters not mentioned equal to 0.

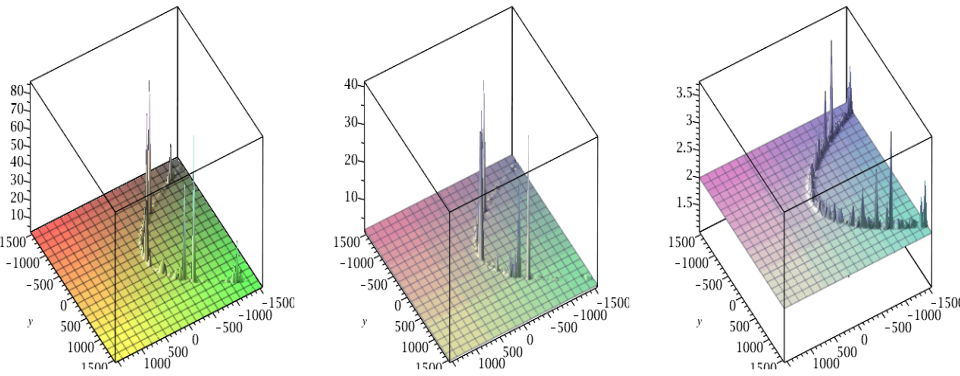

Figure 13. Solution of order 4 to (1), on the left for $t = 0,01$, $a_1 = 10^3$; in the center for $t = 0,01$, $a_1 = 10^5$; on the right for $t = 0,01$, $a_2 = 10^3$; all other parameters not mentioned equal to 0.

In these constructions, we note that the initial rectilinear structure becomes deformed very quickly as time t increases. The heights of the peaks also decrease very quickly according to time t and this for all the various parameters. Because of the structure of the polynomials, one notices that the modulus of these solutions tend towards value 2 when time t and variables x and y tend towards the infinite.

5.5. Case $N = 5$

Not to lengthen the text, in the case of order 5, we do not give the figures of the modulus of the solutions.

Meanwhile, the study of these configurations makes it possible to give the following conclusions. The variation of the configuration of the module of the solutions is very fast according to time t . When time t grows from 0 to 0,01, one passes from a rectilinear structure with a height of 242 to a horseshoe structure with a maximum height equal to 4. The role played by parameters a_i and b_i is the same one for same index i . Because of the structure of the polynomials, one notices that the modulus of these solutions tend towards value 2 when time t and variables x and y tend towards the infinite.

6. Conclusion

From the previous representations of the solutions to the KPI equation given by the author, we succeed to give solutions to the CKP equation in terms of Fredholm determinants of order $2N$ depending on $2N - 1$ real parameters and in terms of wronskians of order $2N$ depending on $2N - 1$ real parameters. We finally obtain rational solutions to the CKP equation depending on $2N - 2$ real parameters. These solutions can be expressed in terms of a ratio of two polynomials of degree $2N(N + 1)$ in x , t and $4N(N + 1)$ in y depending on $2N - 2$ parameters. That gives a new approach to find explicit solutions for higher orders and try to describe the structure of those rational solutions.

In the (x, y) plane of coordinates, different structures appear. But, unlike rational solutions of NLS or KP equations, there is none well defined structure which appears according to parameters a_i or b_i . So, we cannot make a classification of these solutions here, according to parameters by means of their modulus in the (x, y) plane. It would be important to better understand these last structures.

It will be relevant to go on this study for higher orders.

- [1] R.E. Johnson, Water waves and Korteweg de Vries equation, 1980 J. Fluid Mech., V. **97**, N. 4, 701
- [2] R.E. Johnson, 1997 A Modern Introduction to the Mathematical Theory of Water Waves, (Cambridge: Cambridge University Press)
- [3] M.J. Ablowitz, 2011 Nonlinear Dispersive Waves : Asymptotic Analysis and Solitons, (Cambridge: Cambridge University Press)
- [4] V.D. Lipovskii, On the nonlinear internal wave theory in fluid of finite depth, 1985 Izv. Akad. Nauka. V. **21** N. 8 864
- [5] V.I. Golinko, V.S. Dryuma, Y.A. Stepanyants, On the stability of solitary waves in weakly dispersing media, 1984 in Proc. 2nd Int. Workshop on Nonlinear and Turbulent Processes in Physics, (Kiev, Harwood Acad.: Gordon and Breach) 1353
- [6] V.D. Lipovskii, V.B. Matveev, A.O. Smirnov, between the KP equation and the Johnson equation, Connection 1986 Zap. Nau. Sem. V. **150** 70
- [7] B.B. Kadomtsev, V.I. Petviashvili, On the stability of solitary waves in weakly dispersing media, 1970 Sov. Phys. Dokl., V. **15** N. 6 539
- [8] C. Klein, V.B. Matveev, A.O. Smirnov Cylindrical Kadomtsev Petviashvili equation: old and new results, 2007 Theor. Math. Phys. V. **152** N. 2 1132
- [9] K.R. Khusnutdinova, C. Klein, V.B. Matveev, A.O. Smirnov, On the integrable elliptic cylindrical K P equation, 2013 Chaos, V. **23** 013126
- [10] P. Gaillard, Families of quasi-rational solutions of the NLS equation and multi-rogue waves, J. Phys. A : Meth. Theor., V. 44, 1-15, 2010

- [11] P. Gaillard, Degenerate determinant representation of solution of the NLS equation, higher Peregrine breathers and multi-rogue waves, *Jour. Of Math. Phys.*, V. 54, 2013, 013504-1-32
- [12] P. Gaillard, V.B. Matveev, Wronskian addition formula and its applications, *Max-Planck-Institut für Mathematik, MPI 02-31*, V. **161**, 2002
- [13] P. Gaillard, A new family of deformations of Darboux-Pöschl-Teller potentials, *Lett. Math. Phys.*, V. **68**, 77-90, 2004
- [14] P. Gaillard, V.B. Matveev, New formulas for the eigenfunctions of the two-particle Calogero-Moser system, *Lett. Math. Phys.*, V. **89**, 1-12, 2009
- [15] P. Gaillard, V.B. Matveev, Wronskian and Casorai determinant representations for Darboux-Pöschl-Teller potentials and their difference extensions, *RIMS Kyoto*, N. 1653, 1-19, 2009
- [16] P. Gaillard, V.B. Matveev, Wronskian and Casorai determinant representations for Darboux-Pöschl-Teller potentials and their difference extensions, *J. Phys A : Math. Theor.*, V. **42**, 1-16, 2009
- [17] P. Gaillard, From finite-gap solutions of KdV in terms of theta functions to solitons and positons, *halshs-00466159*, 2010
- [18] P. Gaillard, Families of quasi-rational solutions of the NLS equation and multi-rogue waves, *J. Phys. A : Meth. Theor.*, V. **44**, 1-15, 2011
- [19] P. Gaillard, Wronskian representation of solutions of the NLS equation and higher Peregrine breathers, *J. Math. Sciences : Adv. Appl.*, V. **13**, N. 2, 71-153, 2012
- [20] P. Gaillard, Degenerate determinant representation of solution of the NLS equation, higher Peregrine breathers and multi-rogue waves, *J. Math. Phys.*, V. **54**, 013504-1-32, 2013
- [21] P. Gaillard, Wronskian representation of solutions of NLS equation and seventh order rogue waves, *J. Mod. Phys.*, V. **4**, N. 4, 246-266, 2013
- [22] P. Gaillard, V.B. Matveev, Wronskian addition formula and Darboux-Pöschl-Teller potentials, *J. Math.*, V. **2013**, ID 645752, 1-10, 2013
- [23] P. Gaillard, Two parameters deformations of ninth Peregrine breather solution of the NLS equation and multi rogue waves, *J. Math.*, V. **2013**, 1-111, 2013
- [24] P. Gaillard, Two-parameters determinant representation of seventh order rogue waves solutions of the NLS equation, *J. Theor. Appl. Phys.*, V. **7**, N. **45**, 1-6, 2013
- [25] P. Gaillard, Six-parameters deformations of fourth order Peregrine breather solutions of the NLS equation, *J. Math. Phys.*, V. **54**, 073519-1-22, 2013
- [26] P. Gaillard, Deformations of third order Peregrine breather solutions of the NLS equation with four parameters, *Phys. Rev. E*, V. **88**, 042903-1-9, 2013
- [27] P. Gaillard, Ten parameters deformations of the sixth order Peregrine breather solutions of the NLS equation, *Phys. Scripta*, V. **89**, 015004-1-7, 2014
- [28] P. Gaillard, The fifth order Peregrine breather and its eight-parameters deformations solutions of the NLS equation, *Commun. Theor. Phys.*, V. **61**, 365-369, 2014
- [29] P. Gaillard, Higher order Peregrine breathers, their deformations and multi-rogue waves, *J. Of Phys. : Conf. Ser.*, V. **482**, 012016-1-7, 2014
- [30] P. Gaillard, M. Gastineau, Eighteen parameter deformations of the Peregrine breather of order ten solutions of the NLS equation, *Int. J. Mod. Phys. C*, V. **26**, N. 2, 1550016-1-14, 2014
- [31] P. Gaillard, Two parameters wronskian representation of solutions of nonlinear Schrödinger equation, eight Peregrine breather and multi-rogue waves, *J. Math. Phys.*, V. **5**, 093506-1-12, 2014
- [32] P. Gaillard, Hierarchy of solutions to the NLS equation and multi-rogue waves, *J. Phys. : Conf. Ser.*, V. **574**, 012031-1-5, 2015
- [33] P. Gaillard, Tenth Peregrine breather solution of the NLS, *Ann. Phys.*, V. **355**, 293-298, 2015
- [34] P. Gaillard, M. Gastineau, The Peregrine breather of order nine and its deformations with sixteen parameters solutions of the NLS equation, *Phys. Lett. A.*, V. **379**, 13091313, 2015
- [35] P. Gaillard, Other 2N-2 parameters solutions to the NLS equation and 2N+1 highest amplitude of the modulus of the N-th order AP breather, *J. Phys. A: Math. Theor.*, V. **48**, 145203-1-23, 2015
- [36] P. Gaillard, Multi-parametric deformations of the Peregrine breather of order N solutions to the NLS equation and multi-rogue waves, *Adv. Res.*, V. **4**, 346-364, 2015
- [37] P. Gaillard, Higher order Peregrine breathers solutions to the NLS equation, *Jour. Phys. : Conf. Ser.*, V. **633**, 012106-1-6, 2016
- [38] P. Gaillard, M. Gastineau Patterns of deformations of Peregrine breather of order 3 and 4, solutions to the NLS equation with multi-parameters, *Journal of Theoretical and Applied Physics*, V. **10**, 1-7, 2016
- [39] P. Gaillard, M. Gastineau Twenty parameters families of solutions to the NLS equation and the eleventh Peregrine breather, *Commun. Theor. Phys*, V. **65**, 136-144, 2016
- [40] P. Gaillard, Rational solutions to the KPI equation and multi rogue waves, *Annals Of Physics*, V. **367**, 1-5, 2016

- [41] P. Gaillard, M. Gastineau Twenty two parameters deformations of the twelfth Peregrine breather solutions to the NLS equation, *Adv. Res.*, V. , 1-11, 2016
- [42] P. Gaillard, Towards a classification of the quasi rational solutions to the NLS equation, *Theor. And Math. Phys.*, V. **189**, 1440-1449, 2016
- [43] P. Gaillard, Fredholm and Wronskian representations of solutions to the KPI equation and multi-rogue waves, *Jour. of Math. Phys.*, V. **57**, 063505-1-13, doi: 10.1063/1.4953383, 2016
- [44] P. Gaillard, M. Gastineau Families of deformations of the thirteenth Peregrine breather solutions to the NLS equation depending on twenty four parameters, *Jour. Of Bas. And Appl. Res. Int.*, V. **21**, N. 3, 130-139, 2017
- [45] P. Gaillard, From Fredholm and Wronskian representations to rational solutions to the KPI equation depending on $2N^2$ parameters, *Int. Jour. of Appl. Sci. And Math.*, V. **4**, N. 3, 60-70, 2017
- [46] P. Gaillard, Families of Rational Solutions of Order 5 to the KPI Equation Depending on 8 Parameters, *New Hor. in Math. Phys.*, V. 1, N. 1, 26-31, 2017
- [47] P. Gaillard, 6-th order rational solutions to the KPI Equation depending on 10 parameters, *Jour. Of Bas. And Appl. Res. Int.*, V. **21**, N. 2, 92-98, 2017
- [48] P. Gaillard, N -Order rational solutions to the CKP equation depending on $2N - 2$ parameters, *Int. Jour. of Adv. Res. in Phys. Sci.*, V. **4**, N. 9, 19-37, 2017
- [49] P. Gaillard, Families of rational solutions to the KPI equation of order 7 depending on 12 parameters, *Int. Jour. of Adv. Res. in Phys. Sci.*, V. **4**, N. 11, 24-30, 2017
- [50] P. Gaillard, Rational solutions to the CKP equation and rogue waves, *Int. Jour. of Inn. In Sci. and Math.*, V. **6**, N. 1, 14-19, 2018
- [51] P. Gaillard, Multiparametric families of solutions of the KPI equation, the structure of their rational representations and multi-rogue waves, *Theo. And Mat. Phys.*, V. **196**, N. 2, 1174-1199, 2018
- [52] P. Gaillard, The CKP Equation, Fredholm and Wronskian representations of solutions and the case of order three, *Adv. In Math. Phys.*, V. **2018**, 1-18, 2018