



HAL
open science

Simulation-based toolchain for the design of a haptic-based roll axis protection in helicopter

Gemma Prieto-Aguilar, Laurent Binet, Thomas Rakotomamonjy

► **To cite this version:**

Gemma Prieto-Aguilar, Laurent Binet, Thomas Rakotomamonjy. Simulation-based toolchain for the design of a haptic-based roll axis protection in helicopter. ODAS - 19th ONERA-DLR Aerospace Symposium, Jun 2019, Meudon, France. hal-02421349

HAL Id: hal-02421349

<https://hal.science/hal-02421349>

Submitted on 20 Dec 2019

HAL is a multi-disciplinary open access archive for the deposit and dissemination of scientific research documents, whether they are published or not. The documents may come from teaching and research institutions in France or abroad, or from public or private research centers.

L'archive ouverte pluridisciplinaire **HAL**, est destinée au dépôt et à la diffusion de documents scientifiques de niveau recherche, publiés ou non, émanant des établissements d'enseignement et de recherche français ou étrangers, des laboratoires publics ou privés.

SIMULATION-BASED TOOLCHAIN FOR THE DESIGN OF A HAPTIC-BASED ROLL AXIS PROTECTION IN HELICOPTER

Gemma PRIETO-AGUILAR¹, Laurent BINET², Thomas RAKOTOMAMONJY²

¹PhD Student with SAFRAN Electronics & Defense, Massy, and Sorbonne University, Paris, France.

e-mail : gemma.prieto-aguilar@safrangroup.com

²ONERA, Centre de Salon de Provence, Base Aérienne 701, 13661 Salon Air, France

e-mails : Laurent.Binet@onera.fr, Thomas.Rakotomamonjy@onera.fr

Abstract

The latest evolution of pilot controllers, referred to as ASSU (Active Side Sticks Units) provides static and dynamic tactile force (or haptic) feedback to the pilot at the grip. Combined with FBW (fly-by-wire), this promising technology has enhanced safety levels compared to the original mechanical linkage systems they have started to replace, while offering vast improved benefits in terms of carefree handling and pilot situational awareness.

In the framework of a PhD thesis, the Information Processing and Systems Department (DTIS) of ONERA and SAFRAN Electronics & Defense have started a cooperation to evaluate the interest and the different possibilities offered by the ASSU technology to improve safety and handling qualities of rotary wing aircraft.

Up to now, the design and tuning of these functions were essentially performed thanks to numerous simulator sessions or flight tests with pilots. More than just providing a set of values for the required parameters defining the cueing function (hopefully an optimal set of parameters), it is expected that the approach presented here would reduce the number of piloted simulation tests and associated difficulties of the availability of pilots, the significant amount of time and material resources.

The main objective of this work is to develop a design methodology based on the simulation of the entire helicopter control loop (also including the pilot in some form) and enabling the definition and parameterization of cueing functions.

Moreover, some objective criteria will be defined and used to design the force feedback laws, bringing additional means of evaluation and validation than the classical subjective rating scales.

Keywords

helicopter ; side-stick ; haptic feedback ; simulation ; flight envelope protection

Notations and acronyms

| | |
|-----------------|---|
| ACAH | Attitude Command Attitude Hold |
| (A)FCS | (Automatic) Flight Control System |
| ASSU | Active Side-Stick Unit |
| SS | “Soft Stop” |
| RCAH | Rate Command Attitude Hold |
| SAS | Stability Augmentation System |
| TAS | True Air Speed |
| V _x | Longitudinal velocity |
| V _z | Vertical velocity |
| φ, ψ | Resp. bank and yaw angles (in Euler angular coordinates system) |

1. Introduction

In the early days of aviation, aircraft control was based on the use of mechanical linkages between the flight control surfaces (ailerons, rudder for aircrafts, swashplate for helicopters) and the pilot's commands. The development of civil and military aviation, and the emergence of increasingly larger, faster and more agile aircraft, led to greater efforts on commands and the need of assistance systems. This is when hydromechanical controls appear: the mechanical linkages are now connected to actuators to move the different control surfaces. This system represented a cost of maintenance too important for the civil aviation, what made the mechanical linkages to be replaced by electrical wires, and the actuators by servo-motors. Nowadays this technology, known as "fly-by-wire", is used on the most popular commercial transport aircrafts.

Aircraft manufacturers have followed different trends concerning the pilot's commands, offering each one different benefits. SAFRAN Electronics & Defense (E&D) is currently working on the maturation and development of its own Active Side Stick Unit (ASSU). This arising technology offers:

- better ergonomics, offering a clear view to flight displays ;
- an ability to restore static forces, lost with the transition to the "fly-by-wire" commands; and generate dynamically different haptic feedbacks. Combined with a monitoring of different flight variables, these haptic cues can, for example, prevent the approach to the pilot of critical flight situations like entering stall [1] or Vortex-Ring State [2].

A lot of studies have already shown that using ASSUs and dedicated haptic cues are numerous:

- a pilot workload reduction and situational awareness improvement ;
- an improvement of the flight envelope safety ;
- better performances of the aircraft, since the pilot can apply instructions without hesitation ;
- an electronical coupling of the pilot's and copilot's command inputs.

The ASSUs offer the possibility of generating forces in the grip which can be felt by haptic sense of the pilot. These forces can be adjusted to vary with time, angular position of the grip, aircraft state variables, aircraft/helicopter limitations and other parameters that are related to the flight envelope security. This set of forces defines the static characteristics of the ASSU, and can be decomposed by a combination of elementary "feel modules", such as SoftStops (SS), detents, gates, friction, vibrations, all of these in addition to the baseline linear force-displacement law (see Figure 1). The gradient (slope) of this nominal curve will be referred to as the Q-feel (QF) parameter, as denominated by some manufacturers.

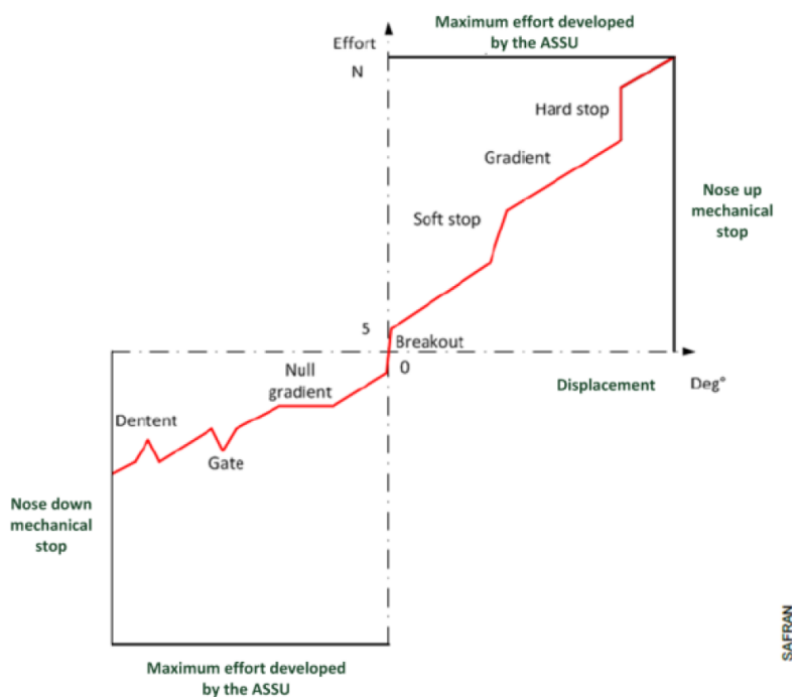

Figure 1 : Static Force/Displacement curve showing different type of force feedbacks

We also use dynamic parameters to refer to the damping ratio and the response frequency of the ASSU (as explained later, the ASSU emulates the behavior of “classical” mechanical sticks or yokes, so its controller drives it to behave as a physical, linear second order system mass-spring-damper).

SAFRAN E&D wishes to highlight the performance of its active stick with the demonstration of the capabilities of this new haptic feedback technology. Thus, in the framework of a PhD thesis, the Information and Systems Processing Department (DTIS) of ONERA-Salon de Provence and SAFRAN E&D have started a cooperation to evaluate the interest and the different possibilities offered by the mini active sticks in order to improve the safety and flying qualities of rotary and fixed wing aircraft.

More specifically we aim to bring focus on the following problematics:

- What are the different fields in which a mini-stick can offer piloting assistance and protection of the flight envelope?
- How to define, ab initio, or in an optimal way, the haptic cues and integrate them in the control loop?

A state of the art has been done to understand the advances made on this subject, and to evaluate the different possibilities to answer these questions. So far, to our knowledge, there is a lack of formal methods for defining haptic cues, other than simulator experimentation with pilots. Thus, we will seek through this thesis to:

1. Develop tools and define criteria that will allow the specification of optimal force feedback laws.
2. Model a complete simulation loop to evaluate the haptic cues defined from these criteria ;

It is expected that this approach will help the development and testing of haptic cues, by reducing the number of simulator trials.

Thus, the following sections will describe the work carried out to develop this simulation/evaluation environment of haptic feedback laws, and more precisely focus on:

- The complete helicopter control loop simulation setup, comprised of Functional blocks: Helicopter flight mechanic code – RCAH augmented control law – Active side-stick model – guidance module – pilot activity model – cueing algorithms);
- The development of a pilot activity model, integrating tactile sensitivity to take into account the cueing function while performing a prescribed piloting task;
- The operational test case setup and cueing function design;
- Preliminary developments of a behavioral logic to apply during a piloting task, depending on the goal of the cueing function (Guidance/Envelope protection function)
- The analysis of the results

2. Overall of the simulation loop

The objective of this thesis is to develop a methodology to design a cueing function for given test cases. This design methodology is based on the simulation of the complete helicopter control loop which can be broken down into different functional blocks as shown in Figure 2.

This haptic evaluation loop should allow, ab initio, the (optimal) specification of the different ASSU's parameters from the definition of performance criteria such as the correct completion of a piloting task or the non-exceedance of flight parameter limits. Thus, a complete helicopter simulation control loop has been developed, integrating a module of the dynamics of each element, namely the flight mechanics of the helicopter, the behavior of the ASSUs, and a pilot activity module (Figure 2).

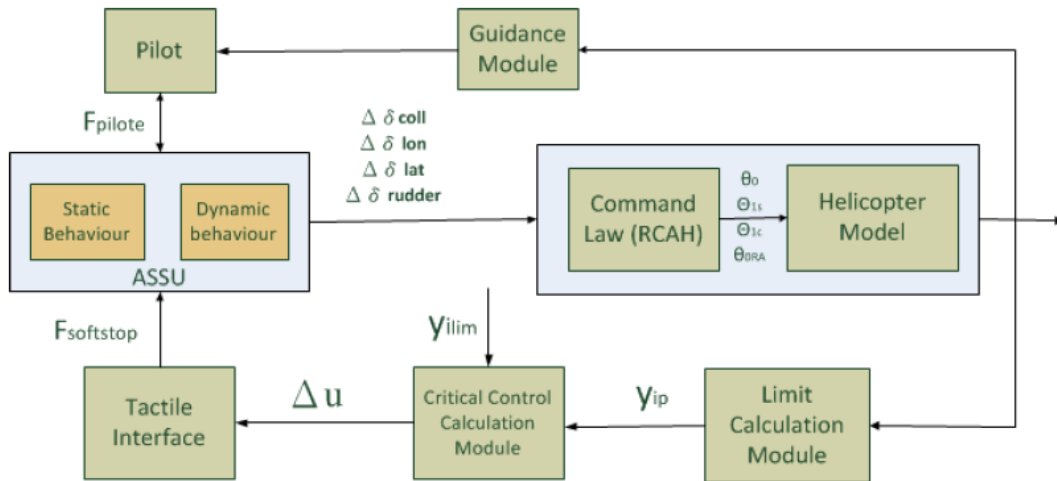

Figure 2 : Complete simulation loop for haptic cueing design, including the following functional blocks: Helicopter flight mechanic code – Augmented control laws (RCAH) – Active side-stick model – guidance module – cueing algorithms - pilot activity model

2.1 Helicopter flight mechanic code

The helicopter dynamics are provided by the full non-linear flight mechanics code FlightLab, developed by Advanced Rotorcraft Technology. The helicopter model used is an OH-6A model [3].

2.1.1 Augmented control laws (RCAH) and AFCS modes

Several FCS modes can be selected on different axis (ATT, SAS, Vx/Vz hold). An augmented RCAH control law has been adapted to the OH-6A helicopter model used in this study.

2.1.2 Active side-stick model

The ASSU model reproduces the behavior of classical sticks (dynamic behavior) and moreover, it offers the possibility of generating a compound force gradient called SoftStop (see Figure 1) on the grip, which can be adjusted to vary with time and aircraft state variables.

The first objective of an active side-stick is to reproduce the behavior of “classical” mechanical sticks or yokes. A mass-spring-damper system is then generally accepted as a model of the ASSU. Therefore, the active stick can be modeled by a force input position-output system of second order for each one of its axes:

$$\frac{x}{F_{\text{pilot}}}(s) = \frac{1}{K} \frac{\omega_n^2}{s^2 + 2\xi\omega_n s + \omega_n^2}$$

where F_{pilot} (N) is the force exerted by the pilot to move the stick, x (deg) is the displacement variable corresponding to the position of the stick¹, ω_n (rad/s) is the model eigenfrequency, K (N/deg) is the spring's stiffness of the system, ξ (no unit) is the damping and s is the Laplace operator. This model is implemented by default on the ASSU controller.

2.1.3 Guidance module

A guidance module, which allows the transmission of pilot instructions in terms of flight parameters (for instance, hold an inclination angle or a forward speed). This module will be improved in future developments, enabling more complex piloting tasks.

2.1.4 Cueing algorithm module

The model includes, in the feedback loop to the stick, a cueing module allowing the computation of the parameter to be limited, and its conversion into flight “desired/prescribed” commands presented to the pilot via the ASSU.

As this will be explained later, the first cueing function chosen for the modeling of the simulation loop was the limitation of the bank angle to cue the pilot to limit φ to a maximum prescribed value. The helicopter model being “augmented” with a RCAH (Rate Command Attitude Hold) control law, the stick positions directly controls the angular speeds a.k.a. roll rate and pitch rate. An automatic turn coordination law (in order to cancel sideslip) has been added.

The Haptic Module provides the force feedback law to be generated on the stick and its definition remains one of the main objectives of this thesis. Among all potential haptic feedbacks, the SoftStop is certainly the most appropriate to indicate such a limitation, because the pilot has to keep the ability to overcome the force cueing if he ever needs to (e.g. for an emergency avoidance or recovery maneuver).

It has been decided to generate a SoftStop on the lateral axis to, at least, warn the pilot of the roll angle limit, and hopefully to prevent any exceedance. The main objective is then to find, through this off-line simulation loop, the characteristics of this SoftStop (amplitude, gradient).

The cueing module has to compute the position of the SoftStop. Thus, the equation below provides the maximum pilot command in lateral axis δDDL_0 before reaching the maximum roll angle value φ_{max} :

$$\delta DDL_0 = \sqrt{\frac{2c\Delta\varphi}{\varphi_{\text{max}}}}$$

where c is the SoftStop return speed to neutral position, and $\Delta\varphi$ the difference between φ_{max} and the current helicopter bank angle φ .

2.2 Pilot Model

The design of a pilot activity model has been undertaken. This pilot model has to be able to follow a prescribed trajectory, or a piloting task, while being acting on the ASSU second order model and potential haptic force feedbacks, as well as controlling a full non-linear helicopter model with augmented control laws.

For the “piloting” task, a precision pilot model, proposed by McRuer [4], has been integrated. It provides a list of some aspects of human behavior, hereby modeled as a transfer function between a piloted output variable and a reference input variable (e.g. a target to follow). This model adds the neuromuscular dynamics of the pilot to the well-known crossover model:

$$Y_p Y_c = \frac{\omega_o e^{-\tau s}}{s}$$

where Y_p and Y_c are respectively the pilot and the aircraft transfer functions, ω_o is the (open loop) crossover frequency, and τ the transport delay time caused by the pilot neuromuscular system.

¹ If x corresponds to an angular deflection of the stick, then it would be more correct to express F_{pilot} as a torque, rather than a linear force. However, most of the manufacturers and publications make the implicit conversion by multiplying/dividing by the grip length (lever arm) when necessary.

3. Sensibility experiment

Since the goal of the study is to determine cueing function parameters based on this complete simulation loop, it is also necessary to provide to the pilot activity model detection criteria so it is able to take into account the presence of a force feedback. It is expected that the shape of the force feedback (amplitude, force gradient, position, etc.) will change the way it is detected, and thus will have an impact on the realization of the piloting task and/or on the limitation of some flight parameters, etc.

An experiment was set up on the PycsHel helicopter prototyping and evaluation simulator at ONERA [5] to assess the force detection thresholds of actual pilots on the ASSU (see Figure 4 and Figure 5). The data obtained were analysed with statistical methods adapted to the study of ASSU's parameters. While only roll-axis was tested, some insight about the effect of ASSU's parameters on the haptic detection has been obtained.



Figure 3: the CAVE configuration of the PycsHel simulator at ONERA Salon de Provence

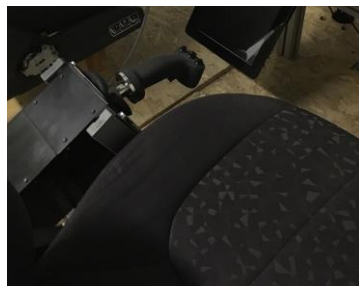

Figure 4: the ASSUs used respectively as collective stick (left) and cyclic stick (right)

3.1 Experimental protocol

The subject was instructed to perform a simple flying task, where he would have to follow the position of a target located at a fixed distance in front of him (i.e. moving at the same forward speed as the helicopter), and moving randomly up and down along a vertical axis. The subject controlled the vertical motion of the helicopter through the collective stick, and a projection of its altitude was given in order to evaluate the relative positioning error. Meanwhile, the subject was also instructed to move the stick laterally from left to right, and back, and to press the stick trigger whenever he encounters a SoftStop during the sweeping motion. Actually, the objective of the vertical tracking task was to ensure that the subject was not too precisely focused on the detection of the SS, similar to how an actual pilot would be engaged in a more or less complex, multi-tasked and cognitively loaded flying activity.

A simplified, linearized model was used to simulate the lateral flight dynamics of the helicopter. The forward speed was kept constant, while the vertical motion was highly damped, in order for non-pilot / non-expert subjects to run the task. A total of 6 sets of SoftStop combinations were tested in which the frequency or damping of the ASSU model is modified (Table 1). A total of 6 subjects performed all the sets, preceded by a familiarization phase. Each one of the sets consists of 144 combinations of SS randomly distributed and repeated 3 times.

| Parameter | Values |
|---------------------------|---|
| Frequency $\omega_n/2\pi$ | [3 ; 5] (Hz) |
| Damping ξ | [0.5 ; 0.75 ; 1.25] |
| QF | [0.5 ; 1 ; 1.25] (N/deg) |
| Motion speed | [slow ; fast] |
| SoftStop amplitude | [3 ; 6 ; 9] (N) |
| SoftStop position | [± 3 ; ± 7 ; ± 10 ; ± 14] (deg) |

Table 1 : Summary of ASSU and SoftStop parameters tested

3.2 Overview of results

A multiple linear regression was attempted in order to predict the force applied by the pilot at the moment of the SS detection, as a function of the different haptic and ASSU's parameters. However, so far no representative regression model based on the force has been obtained, which could led to the conclusion that the force detection as a function of the different ASSU's parameters do not follow a linear law.

On Figure 5 we can observe how the response (deflection) of the stick to a pilot force input differs from the linear static law in the presence of a SoftStop, this dynamic behavior being more significant as the force introduced by the pilot is important. In addition, it can be seen that the stick is unable to stop its motion while traversing the SoftStop.

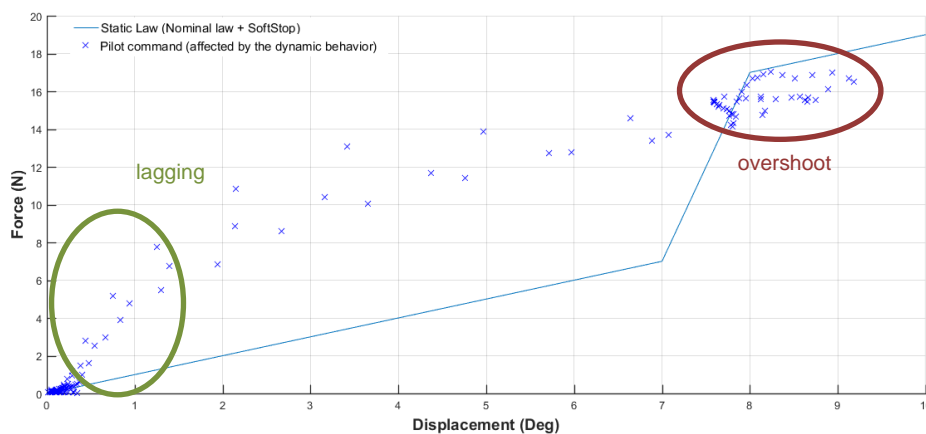

Figure 5: overshoot generated, in comparison with the linear law, in response to a command with the ASSU

This behavior can be easily explained when looking at the indicial (step) response of a 2nd order system for different values of the damping coefficient, as seen on Figure 6 below.

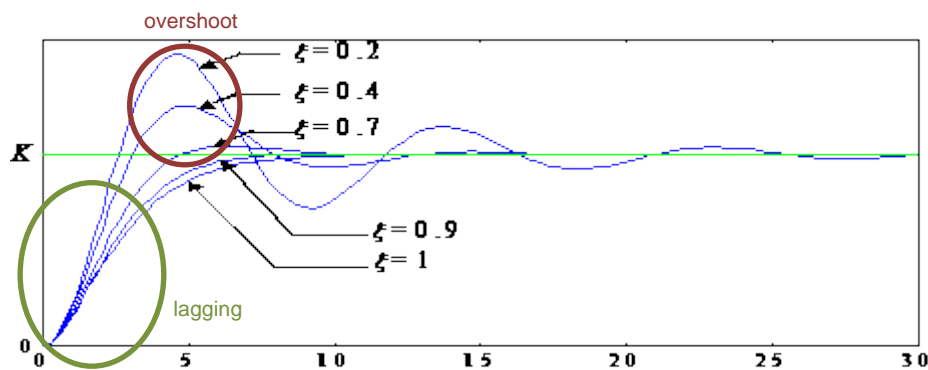

Figure 6: step response of a 2nd order system

This undoubtedly affects haptic detection, since the pilots could detect the force gradient variation at different points, or even “fly over” the SoftStop without noticing it. This behavior is not noticeable with the SAFRAN's ASSU, since it uses control laws which prevent overtaking without generating an important position lag. This control laws regulates the damping and inertia intervals which allow a stable use of the ASSU. Future experiments led with this system should provide more repeatable and consistent results.

The Table 2 summarizes mean force detection for a given set of ASSU's parameters where it can be shown some of the trends:

- Greater overruns on positions close to the neutral ($\pm 3^\circ$) and a tendency to stabilize the detection force average for the other positions.
- Greater efforts with increasing SS amplitude

| Damping= 0.75, Frequency= 3, QF=1, Slow Speed | | | | | | | | |
|---|------|------|------|------|------|------|------|------|
| Amp \ Pos | -14 | -10 | -7 | -3 | 3 | 7 | 10 | 14 |
| 3 | 2.29 | 1.70 | 1.26 | 5.50 | 3.77 | 2.26 | 2.31 | 2.25 |
| 6 | 4.68 | 3.05 | 3.14 | 5.02 | 5.23 | 4.39 | 4.87 | 4.25 |
| 9 | 4.18 | 4.57 | 4.74 | 6.51 | 7.04 | 5.06 | 3.89 | 4.13 |

Table 2: Mean force trends as a function of amplitude and position of the SoftStop for different sets of damping, frequency and static force gradient (QF)

According to these results, it was concluded that:

- 1) Pilots are sensitive to **force gradient variations**, since subjects have shown better detections with little gradients of the nominal law (QF=0.5). Little QF values have also shown to be more sensitive to high speeds, leading to a higher number of overtaking. A good compromise could be a QF value of 1.
- 2) Pilots are sensitive to **ASSU's damping**. Sets tested with high damping values have proven less SS's detection because it implies the arm's muscles to be contracted. On the other hand, higher damping values improve precision during helicopter's command and avoid overtaking the SS during high speeds. A good compromise could be a damping value of 0.75.
- 3) **SoftStop's positions** influence on their detection. SSs positioned outwards have been more detected than SSs placed inwards. This could be explained physiologically by the well-known fact that we are stronger on inward (pronation) movements, and thereby less sensitive. Subjects also avoided confusing furthest SS with the mechanical stop. At furthest positions, the subject needs to apply a highest force, which implies a tension on the arm's muscles and a worse sensibility to force gradients. Additionally, SSs placed near the trim position presented less detection, which can be explained by the second order dynamics of the system. In fact, during rapid force inputs the response of the system deviates from the linear static law. Moreover, a breakout force (to avoid any stick displacement due to small/unintentional applied force) is generally placed at the stick trim position, needing an additional force to initiate the stick.

4. Tactile sensitivity and logics of the pilot activity model

The results of the previous experiments were used to define preliminary detection criteria which were integrated in the pilot activity model.

Figure 7 shows a simulation reproducing the experiment, where the pilot model was instructed to stop moving the stick exactly when the SoftStop was detected.

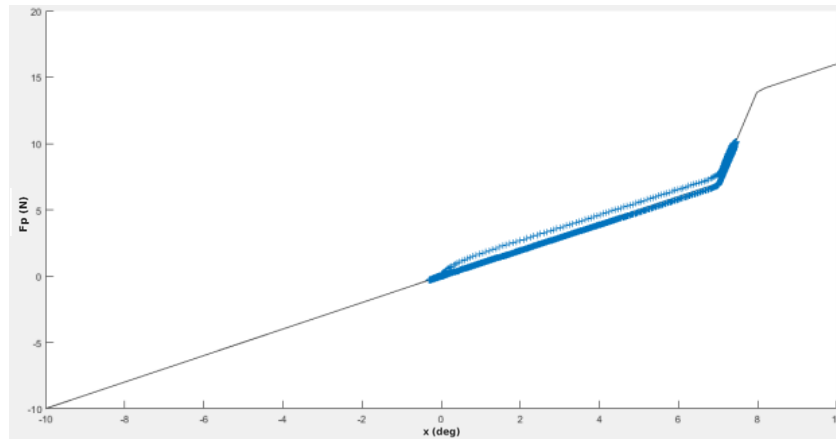

Figure 7 : SoftStop static Force/Displacement curve and detection

The conclusions obtained about pilot haptic detection were used to modify the pilot activity model in order to adapt the pilot model behavior if any SoftStop appeared. More specifically, we used the result 1), according to which pilots would be sensitive to force gradients, defined as the instantaneous derivative of the applied force w.r.t. the stick position: $\frac{\partial F_{\text{pilot}}}{\partial x}$.

As long as the pilot stays on the nominal (pre-SoftStop) law, the value of the above quantity is constant and more or less equal to the QF value (the difference being explained by the dynamical component of the response, as explained in the previous section). However, if the pilot encounters a SoftStop, this gradient value increases. As a consequence, a first attempt to introduce a simplified detection model could take the form of a gradient threshold $\left(\frac{\partial F_{\text{pilot}}}{\partial x}\right)_{\text{thr}}$. The determination of the value of this threshold will be the objective of one of the future experimental evaluations using the ASSU developed by SAFRAN E&D.

As an illustration, Figure 8 shows two different commands, for a rolling instruction, of the pilot activity model. The first one (in red), a 6 Newton SoftStop amplitude, leads to an less important overshoot position of grip, and the second one (in blue), a 3 N SoftStop amplitude, generates a bigger displacement. This example shows that the different haptic parameters do not only affect the pilot detectability, but also the performances of a piloting task.

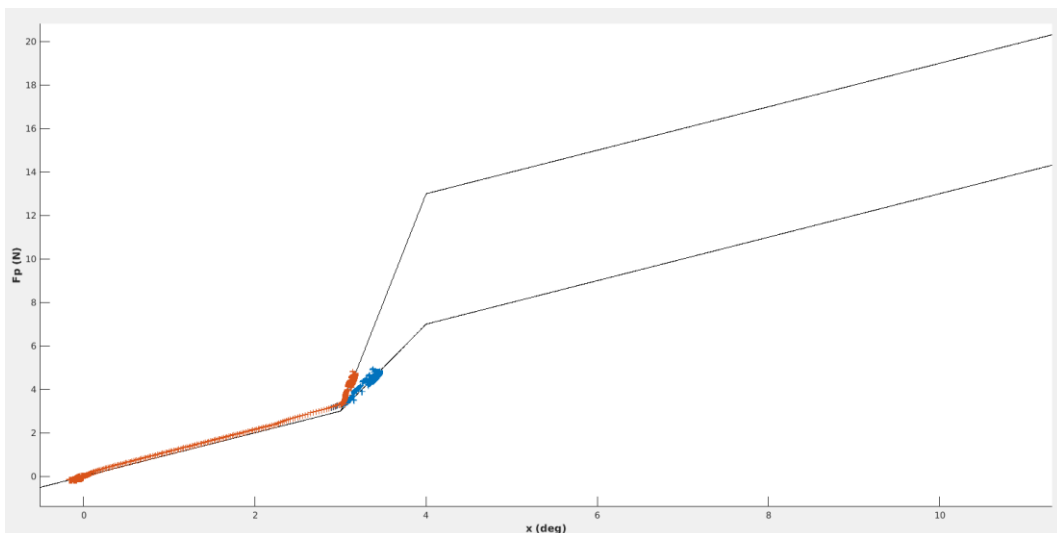

Figure 8 : two nominal laws with two different Amplitude SoftStops, and the pilot's command for each one of them

Once a change in the ASSU feedback has been detected (e.g. the occurrence of a SoftStop), the compromise between the piloting task to achieve and the presence of the haptic cueing has to be considered through an adequate behavioral logic.

This human perception and behavioral logic has to be taken into account into the pilot model if we want to be able to predetermine the haptic cue parameters through a simulation loop. For instance, the variance of the perception implies variance in the applied commands, i.e. depending on stick parameters and SoftStop design:

- first, a pilot will not detect the SoftStop the same way every time, and he will more or less exceed the SoftStop position (so more or less overshooting the reference command value);
- in a second time, in order to follow the SoftStop position, the pilot will continuously try to “feel” it, applying slight (or large variations if the perception is low) excursions around it.

As a consequence, we have decided for initial evaluation purposes to define the simplest logic behavior for our Pilot Model: maintaining the command around the detection point. This will clearly have an impact on the task-related performance criteria; but not only. The piloting law used (RCAH, ACAH, or direct law), the pilot’s behavior (through the gains of the model), or the (static and dynamic) behavior of the ASSU should modify the pilot’s performance as well. On the other side, when the pilot considers to have reached (or exceeded) his piloting instruction, it can move the grip away from the detection point and bring it back to neutral point (or to the opposite side).

These different logics will be developed and adapted by means of the completion of an operational test case as described in the following chapter.

4. Operational test case

In order to validate the developed methodology, a first operational test case has been selected, consisting in a standard rate IFR turn. This task can be described as a 360° turn in 120 ± 4s (= 3°/s turn rate) with constraints on flight parameters as described in [13].

As previously described, a roll angle guidance algorithm has been setup to feed the cueing function, giving the reference roll angle as a function of yaw rate and airspeed. If we want to cancel the sideslip angle, the lateral flight equilibrium equations lead to:

$$\varphi_{\text{command}} = \arctan\left(\psi \frac{\text{TAS}}{g}\right)$$

Following the constraints, the pilot model receives an instruction to decelerate to 60 kts and to adapt accordingly the bank angle in direct control.

Additionally, a vertical speed-hold mode is activated on the collective axis while turn coordination is provided by the Rate Command Attitude Hold (RCAH) law on the yaw axis. Regarding the airspeed (TAS), it is supposed for now that its value is regulated independently of the existing controls.

Figure 9 shows the IFR-turn achieved by the pilot activity model (blue curves) trying to follow the roll angle target (green curve) and by an Automatic Flight Control System (AFCS) command based on the calculated SoftStop position (red curves). Comparing both results in Figure 9, it can be seen that the “optimal” lateral position provided by the SoftStop (if it were used as an AFCS command), leads to a better performance in accomplishing the standard rate IFR-turn in the specified time. Thus, if the pilot could precisely detect and then follow the SoftStop, he would be able to improve its performance.

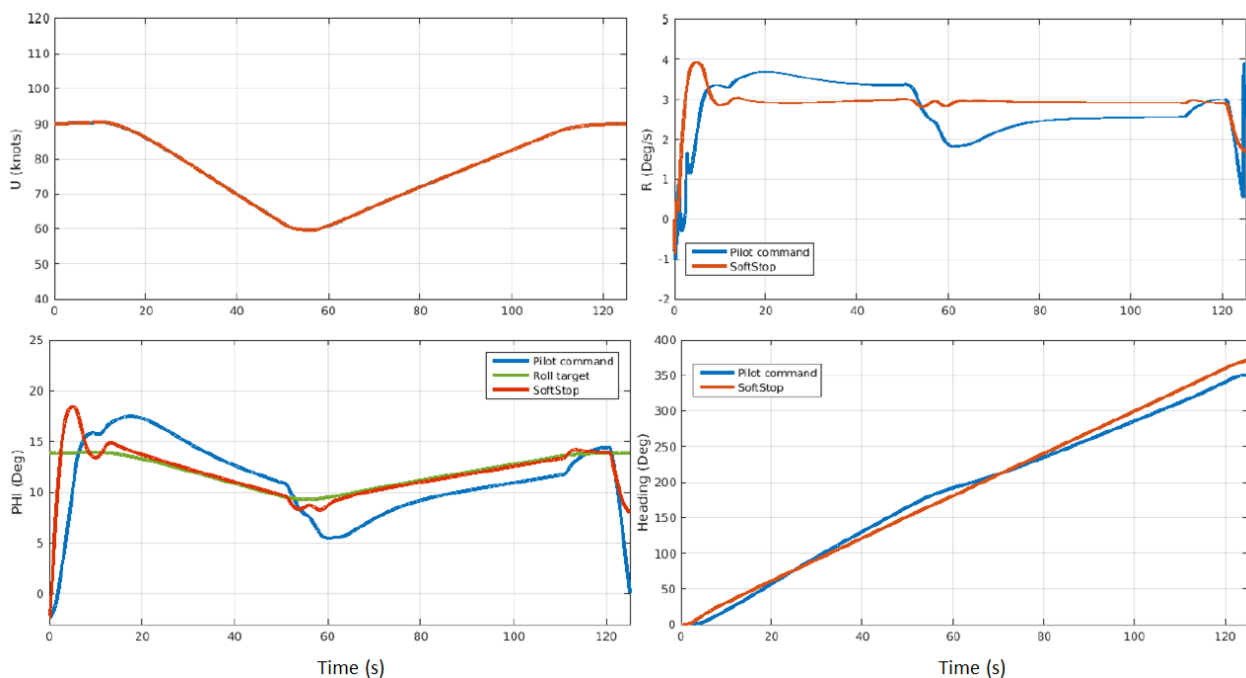

Figure 9 : Comparison of a standard rate turn performed by the pilot activity model and AFCS

Since the current work concerns the definition of the appropriate haptic cue based on the optimization of objective criteria, this means, among other works, finding the haptic cue parameters, such as amplitude and force gradient for a SoftStop, that allow the best detection/recognition and following during a piloting task. For this reason, the pilot activity model capable of detecting SS will be included in the full simulation loop in the next future.

This also implies to include a defined logic for the detection and tracking of the haptic cue. As explained previously, the different logics followed by the pilot model will lead to different performances for the same task.

In the present operational test case (IFR turn), two different applications of the SoftStop can be envisioned:

- the position of the SoftStop acts as an exact indication of the ideal stick deflection to perform the maneuver (guidance);
- or, the position of the SoftStop is an indication of a limit (here, a bank angle) that should not be exceeded in normal flying conditions (but the pilot has still the ability to overpass the SS if he decides to do so).

In the first case, the pilot will have first to find the SoftStop position, then to continually “rest” against it: however, the dynamics of the pilot action in response to a moving SS will have to be modeled, whether the SS is moving towards the pilot input, or away from it. In the second case, the pilot is free to act on the inputs as he wants to accomplish the task, as long as the monitored flight variable stays within the prescribed limits.

Obviously, a pilot model could not be programmed to reproduce a unique, deterministic controlling action (what *any* pilot *will* do), but would rather have a certain variance, so as to reproduce a behavior envelope sufficiently wide (what *some* pilots *may* do). Some preliminary hypothesis will be set in the simulation loop, but will have to be confirmed or invalidated through exploratory simulator tests with pilots.

Figure 10 (pilot and SS command associated with Figure 9) illustrates the problematic of the weighting between following a SoftStop and applying the required commands to perform the piloting task.

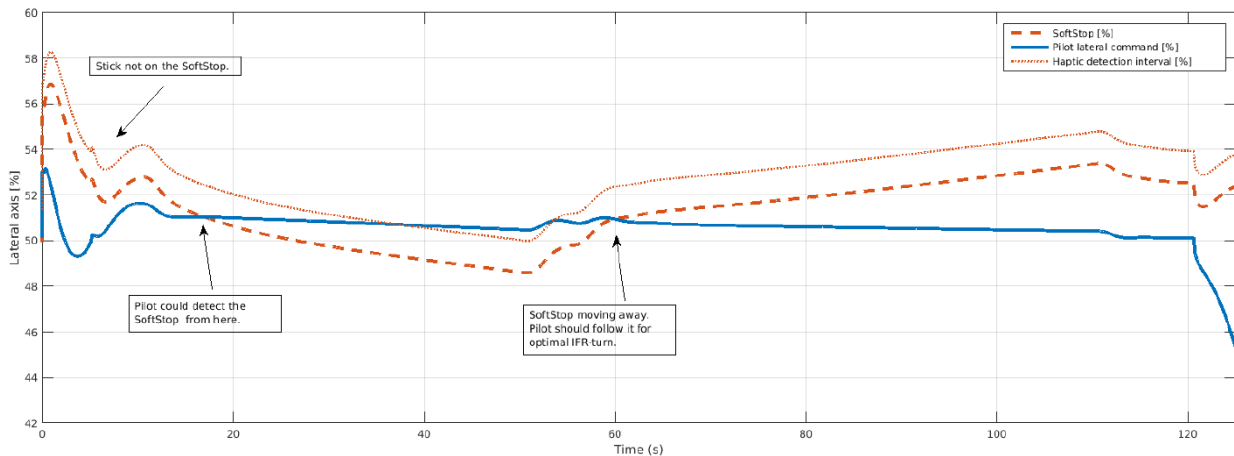

Figure 10 : comparison of pilot and SoftStop command

In order to analyze and compare the influence of the different parameters defining the SoftStop, a first set of criteria can be proposed:

- Simulation domain
 - Performance (task realization), ADS-33 (desired vs adequate)
 - Discrepancies between targets ($\varphi_{command}$) and performed parameter (φ_{pilot})
 - Limit exceedance (φ_{pilot}) compared to (φ_{limit})
 - Stick activity (mechanical energy, time-frequency analysis)
- Piloted evaluation
 - Cognitive workload
 - Situational awareness
 - Pilot acceptance

Using for example the final yaw angle ψ_{end} as a performance criterion, it can be seen on Figure 11 the IFR-turn achieved by the pilot activity model when limited by the SoftStop guidance. The comparison of the task performance (319.9° in 120 s on Figure 11, 340° for the pilot command and 360° for the guidance SoftStop on Figure 9) highlights the fact that the type of force feedback provided, according to goal of the cueing function, needs to be studied. In fact, SoftStops have proved to be the most effective to warn the approach of critical values or limit parameters, but they seem not completely efficient in piloting guidance. Adding a very smooth detent or changing the stick parameters once close to the haptic cue will be studied.

Overall, this operational scenario can be used to show the difference between the logics when SoftStop used as a guiding function, or for a limiting function.

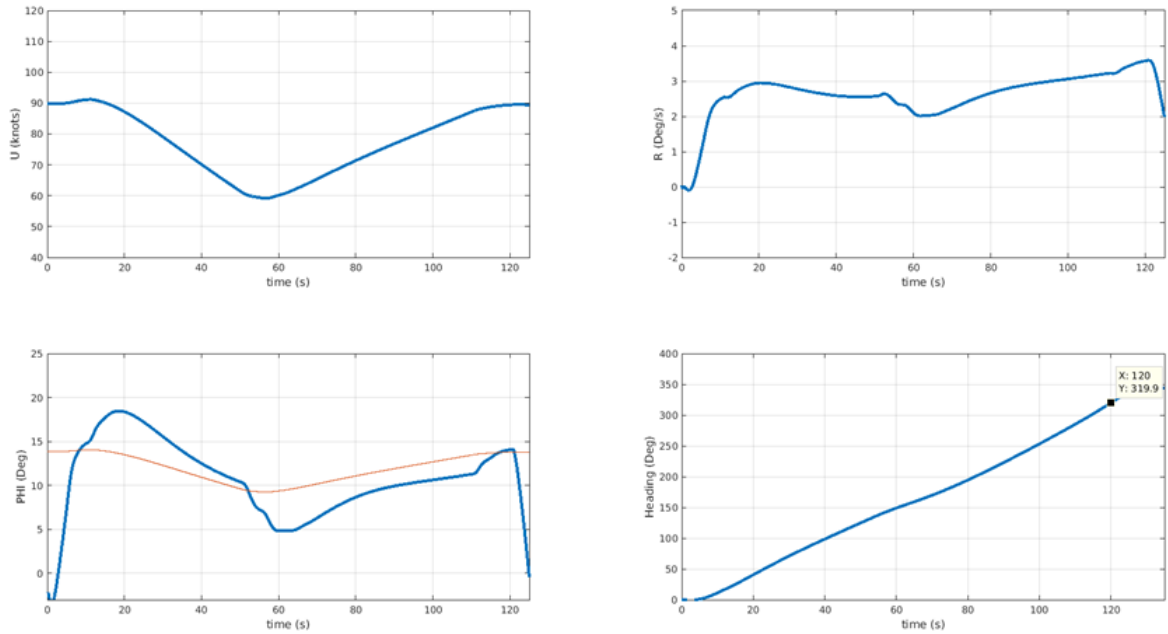

Figure 11 : the IFR-turn achieved by the pilot activity model when limited by the SoftStop guidance

5. Future works

The next steps will focus on:

1. Integrating the detection in the Pilot activity Model within the full simulation loop. This might need another sensibility experiment able to provide detection gradient thresholds.
2. Developing the different logics, adapted to the piloting task and laws, of the pilot activity model during the detection and following of the haptic cues.
3. Establishing the criteria to evaluate the performance of the pilot model (completion of the task, exceeding of the pilot instruction, activity on the grip, etc.)

References

- [1] J. Ellerbroek, M. Rodriguez, T. Lombaerts, M. van Paassen, M. Mulder, *Design and evaluation of a Flight Envelope Protection haptic feedback system*, IFAC-PapersOnLine, 49(19), pp. 171-176, 2016.
- [2] M. Abildgaard, L. Binet, A. Taghizad, W. von Grünhagen. *VRS avoidance as active function on side-sticks*. 65rd Annual Forum of the American Helicopter Society, 2009, Grapevine.
- [3] G. Ouellette, *Modeling the OH-6A using FlightLab and helicopter simulator considerations*, Naval Postgraduate School Thesis, 2002, Monterey.
- [4] D. McRuer, H. Jex, *A review of quasi-linear pilot models*, IEEE Transactions on Human Factors in Electronics, 8(3), pp. 231-249, 1967.
- [5] <https://labsim.github.io/>
- [6] L. Binet, T. Rakotomamonjy, *Using haptic feedbacks for obstacle avoidance in helicopter flight*, 6th European Conference for Aeronautics and Space Sciences (EUCASS), Kraków, juin 2015.
- [7] T. Rakotomamonjy, L. Binet, M. Müllhäuser. French-German joint research on tactile cueing for reactive obstacle avoidance dedicated to low speed helicopter maneuvers. 42nd European Rotorcraft Forum, 2016, Lille.
- [8] S. Cheffi, T. Rakotomamonjy, L. Binet, P. Bidaud, J.-C. Sarrazin. A bi-level optimization approach to get an optimal combination of cost functions for pilot's arm movement: the case of helicopter's flying aid functions with haptic feedback. Digital Human Modeling. Applications in Health, Safety, Ergonomics and Risk Management: Ergonomics and Health, Lecture Notes in Computer Science, 2015, Springer International Publishing.
- [9] M. van Paassen, J. van der Vaart, J. Mulder, Model of the neuromuscular dynamics of the human pilot's arm, Journal of Aircraft, 41, 2004.
- [10] S. Suzuki, K. Furuta, Adaptive impedance control to enhance human skill on a haptic interface system, Journal of Control Science and Engineering, 2012.
- [11] W. von Grünhagen, M. Müllhäuser, M. Abildgaard, R. Lantzsch. Active inceptors in FHS for pilot assistance systems. 36th European Rotorcraft Forum, 2010, Paris.
- [12] M. Müllhäuser, D. Leißling. Development and In-Flight Evaluation of a Haptic Torque Protection Corresponding with the First Limit Indicator Gauge. 69th Annual Forum of the American Helicopter Society, 2013, Phoenix.
- [13] M. Abildgaard, W. von Grünhagen. Demonstration of an Active Sidestick in the DLR Flying Helicopter Simulator (FHS). 34th European Rotorcraft Forum, 2008, Liverpool.
- [14] S. de Stigter, M. Mulder, M. M. van Paassen. Design and evaluation of a haptic flight director. Journal of Guidance, Control and Dynamics, 30(1), 2007.
- [15] J.F. Horn, N. Sahani. Detection and Avoidance of Main Rotor Hub Moment Limits on Rotorcraft. AIAA Atmospheric Flight Mechanics Conference, Montreal Canada, 6 August 2001.
- [16] S. Unnikrishnan. Adaptive Envelope Protection Methods for Aircraft. PhD thesis, Georgia Institute of Technology, 2006.
- [17] D. Miller, P. Einthoven, C. Morse, J. Wood. HACT Flight Control System (HFCS) control law overview. 58th Annual Forum of the American Helicopter Society, 2002, Montreal.
- [18] J.G. Irwin III, B.R. Brown, A.M. Rich, M. Schwerke, E. Kocher. AVMS H-47 Chinook with APAS Tactile Cueing Demonstration Results. 72th Annual Forum of the American Helicopter Society, 2016, West Palm Beach.
- [19] B. Kashawlic, R. Enns, J. Irwin III, R. Moore. Carefree Maneuvering via Tactile Cueing Flight Demonstrations. 72th Annual Forum of the American Helicopter Society, 2016, West Palm Beach.
- [20] B. Kashawlic, R. Enns, B. Brown, R. Moore. Maneuver and Mission Aiding via Tactile Cueing Flight Demonstrations. 72th Annual Forum of the American Helicopter Society, 2016, West Palm Beach.
- [21] V. Sahasrabudhe, R. Spaulding, A. Faynberg, J. Horn, N. Sahani. Simulation Investigation of a Comprehensive Collective-Axis Tactile Cueing System. 58th Annual Forum of the American Helicopter Society, 2002, Montreal, Canada.

- [22] S. Hoelscher, M. Bothwell. 525 Aircraft Zero, The Relentless Advanced Systems Integration Lab. 71th Annual Forum of the American Helicopter Society, 2016, Virginia Beach.
- [23] M.J. Morgan. An Initial Study into the Influence of Control Stick Characteristics on the Handling Qualities of a Fly-By-Wire Helicopter. AGARD-CP-508, 1991.
- [24] J.A. Lusardi, C.L. Blanken, MAJ C.R. Ott, C.A. Malpica, W. Von Grünhagen. In Flight Evaluation of Active Inceptor Force-Feel Characteristics and Handling Qualities. 68th Annual Forum of the American Helicopter Society, 2012, Fort Worth, Texas.
- [25] T. Schönenberg. Development of Rotorcraft Handling Qualities Criteria for Active Sidestick Force-displacement Characteristics. 69th Annual Forum of the American Helicopter Society, 2013, Phoenix, AZ.
- [26] P. Einthoven. Active Controller Performance Requirements. 60th Annual Forum of the American Helicopter Society, 2004, Baltimore, MD.
- [27] C. Malpica, J. Lusardi. Handling Qualities analysis of active inceptor force-feel characteristics. 69th Annual Forum of the American Helicopter Society, 2013, Phoenix.M. Abildgaard. Modeling of a tactile cueing function. DLR.