



**HAL**  
open science

## **Datazero : Designing and operating datacenters powered by renewable energy-based stand-alone microgrids**

Robin Roche, Stéphane Caux, J Lecuivre, Jean-Marc Pierson, Daniel Hissel,  
Jean Nicod

### ► **To cite this version:**

Robin Roche, Stéphane Caux, J Lecuivre, Jean-Marc Pierson, Daniel Hissel, et al.. Datazero : Designing and operating datacenters powered by renewable energy-based stand-alone microgrids. National Scientific Workshop on Micro and Smart Grids, Oct 2017, Chalon sur Marne, France. hal-02392531

**HAL Id: hal-02392531**

**<https://hal.science/hal-02392531>**

Submitted on 4 Dec 2019

**HAL** is a multi-disciplinary open access archive for the deposit and dissemination of scientific research documents, whether they are published or not. The documents may come from teaching and research institutions in France or abroad, or from public or private research centers.

L'archive ouverte pluridisciplinaire **HAL**, est destinée au dépôt et à la diffusion de documents scientifiques de niveau recherche, publiés ou non, émanant des établissements d'enseignement et de recherche français ou étrangers, des laboratoires publics ou privés.

# DATAZERO: DESIGNING AND OPERATING DATACENTERS POWERED BY RENEWABLE ENERGY-BASED STAND-ALONE MICROGRIDS

R. Roche<sup>1</sup>, S. Caux<sup>2</sup>, J. Lecuivre<sup>3</sup>, J.-M. Pierson<sup>4</sup>, D. Hissel<sup>1</sup>, J.-M. Nicod<sup>1</sup>

1. FEMTO-ST, FCLAB, CNRS, Univ. Bourgogne Franche-Comte

2. LAPLACE, Université de Toulouse, INPT, UPS, CNRS

3. EATON Industries France, 38334 St Ismier cedex

4. IRIT, University of Toulouse

e-mail: [robin.roche@utbm.fr](mailto:robin.roche@utbm.fr)

**Abstract** – This paper describes the DATAZERO project, which focuses on the design and operation of datacenters powered by renewable energy and without any emission of greenhouse gas. It describes the selected supply system architecture, in the form of a stand-alone microgrid, as well as the proposed modules for the operation of both power and information technology (IT) sides. The operation philosophy relies on a negotiation between both sides, i.e., between using (and aging) components and reducing the quality of service for IT tasks.

**Keywords** – datacenter, microgrid, renewable energy, degradation, energy management.

## 1. INTRODUCTION

In a context of rising climate change consequences, it has become crucial to facilitate the development of greener datacenters, capable to operate without emission of greenhouse gases [1]. The DATAZERO project, funded by the French National Research Agency from 2015 to 2019, brings together academic (FEMTO-ST, IRIT, LAPLACE) and industry (EATON) partners to help tackle challenges related to the design and operation of MW-scale datacenters solely powered by renewable energy.

## 2. MICROGRID STRUCTURE

The proposed power supply system is a stand-alone microgrid (Fig. 1). It includes renewable energy sources in the form of PV panels and wind turbines, storage units, in the form of supercapacitors, batteries (for short-term storage), and hydrogen storage (combining fuel cells, tanks and an electrolyzer for seasonal storage). This structure enables meeting all datacenter power and energy requirements without any direct emission, and while considering load and generation dynamics.

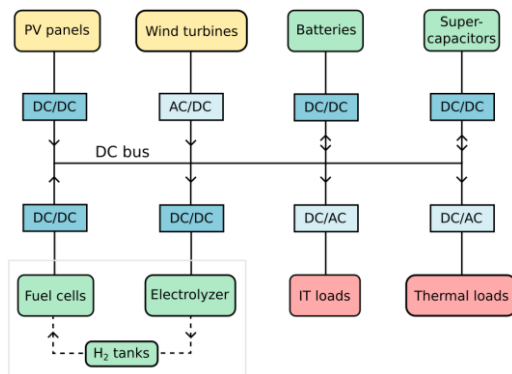

Fig. 1. Datacenter power supply infrastructure.

## 3. SIZING AND ENERGY MANAGEMENT

Models of these different components are established, and include degradation processes which reduce components

performance over time. These models are then used for determining the optimal size of the components, and in the modules described in Fig. 2. For example, the power decision module (PDM) is in charge of scheduling the operation of the components in advance, and of dispatching the power load in real time among the components, accounting for forecasting errors. A similar module (ITDM) exists on the IT side for scheduling IT tasks on servers.

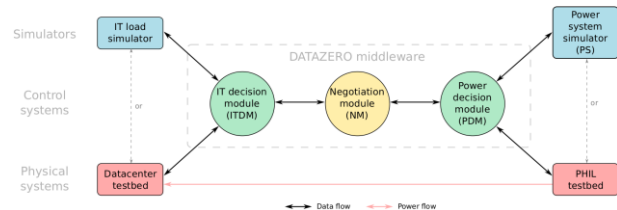

Fig. 2. Overview of the DATAZERO modules.

The negotiation module then handles a negotiation with the IT side to determine the datacenter operation. For example, in the advent of a sudden decrease in PV output, the system can decide to discharge the batteries, or to postpone some IT tasks to be run on the servers.

After simulations will have enabled to verify the correct operation of the designed models and algorithms, a reduced scale power hardware-in-the-loop (PHIL) experiment will be conducted to validate the proposed systems.

## ACKNOWLEDGEMENT

This work was supported by the French Research Agency under the project DATAZERO (ANR-15-CE25-0012).

## REFERENCES

- [1] W. Deng, F. Liu, H. Jin, B. Li and D. Li, "Harnessing renewable energy in cloud datacenters: opportunities and challenges," in IEEE Network, vol. 28, no. 1, pp. 48-55, January-February 2014.