



HAL
open science

Stochastic LQ control under asymptotic tracking for discrete systems over multiple lossy channels

Rongyao Ling, Yu Feng, Fabien Claveau, Philippe Chevrel

► **To cite this version:**

Rongyao Ling, Yu Feng, Fabien Claveau, Philippe Chevrel. Stochastic LQ control under asymptotic tracking for discrete systems over multiple lossy channels. IET Control Theory and Applications, 2019, 13 (18), pp.3107-3116. 10.1049/iet-cta.2018.6234 . hal-02378967

HAL Id: hal-02378967

<https://hal.science/hal-02378967v1>

Submitted on 5 Jan 2023

HAL is a multi-disciplinary open access archive for the deposit and dissemination of scientific research documents, whether they are published or not. The documents may come from teaching and research institutions in France or abroad, or from public or private research centers.

L'archive ouverte pluridisciplinaire **HAL**, est destinée au dépôt et à la diffusion de documents scientifiques de niveau recherche, publiés ou non, émanant des établissements d'enseignement et de recherche français ou étrangers, des laboratoires publics ou privés.

Stochastic LQ Control Under Asymptotic Tracking for Discrete Systems over Multiple Lossy Channels

R. Y. Ling^{1,2}, Y. Feng^{1*}, F. Claveau², Ph. Chevrel²

¹ Information Engineering College, Zhejiang University of Technology, Hangzhou, China.

² Département Automatique, Productique et Informatique, IMT Atlantique, LS2N, UBL, Nantes, France.

* E-mail: yfeng@zjut.edu.cn

Abstract: This paper addresses the asymptotic tracking problem subjected to linear quadratic constraints for linear discrete-time systems, where packet dropout occurs in actuating channels. In order to solve this objective control problem, the controller-coding co-design approach is adopted, i.e., the controller, encoder and decoder are designed for taking full advantage of the network resource collaboratively, thereby achieving better transmission of control signals. A stabilizability condition in the mean square sense that reveals the fundamental limitation among the H_2 norm of the plant, data arrival rates and coding matrices is first derived. Then, a solvability condition is conducted to handle the additional stochastic LQ control objective by a modified discrete-time algebraic Riccati equation, and an iterative algorithm is also given for designing the corresponding state feedback gain and coding matrices. Relied on such design, the asymptotic tracking constraint is further fulfilled through solving a Sylvester equation, and the feedforward gain related to tracking is parameterized. Finally, a simulation with the implementation of the design method on two cooperative robots is included to show the effectiveness of the current results.

1 Introduction

Unlike classical digital control systems, networked control systems (NCSs) are closed-loop systems where the plants, the sensors, the actuators and controllers are coordinated through certain form of communication network. The main features of NCSs are low cost, high reliability, ease of maintenance and expansion [1–3]. Meanwhile numerous special issues on NCSs have been concerned by many researchers, inspired by wide applications of NCSs in cooperative vehicles [4, 5], sensor networks [6, 7], multi-agent systems [8, 9] and so on. In NCSs, the imperfect communication channels can introduce various constraints and uncertainties, for instance, packet dropouts [10, 11], time delays [12, 13], fading [14, 15], limited data rates [16, 17] and quantization [18, 19], etc.

The stabilization of NCSs with networked constraints and uncertainties is a wildly attentional research field and numerous results have been reported in the literatures. For instance, the Lyapunov function approach is applied in [20] to reach the coarsest quantization density required for the stabilization of the single-input discrete-time linear time-invariant system with logarithmic quantized state feedback. Authors in [21] consider a stabilization problem with actuating channel subjecting to packet dropout, and necessary and sufficient conditions are determined in terms of the packet dropout probability and the spectral radius of the system matrix. [22] solves the stabilization problem for single-input system with both packet dropout and logarithmic quantization and the above-mentioned problem for single-input single-output system is solved in [23] by computing two algebraic Riccati equations and an algebraic Riccati inequality, where the tradeoff between the robust stability and the robust performance is revealed. Furthermore, [24] gives the solution for the multi-input multi-output case. The output regulation problem is considered in a cooperative and distributed scheme with constraints as switching network topology in [25]. The regulation problem is alternatively tackled by using input/output weighting filters, and the classical internal model principle is extended to the co-called comprehensive admissibility in [26]. Moreover, in order to find the least total channel capacity achieving stabilization for multi-input NCSs, the technique of channel resource allocation is proposed

in [27] and it is appealed to deal with the constraints as signal-to-noise ratio (SNR), logarithmic quantization and fading [28, 29]. For channel resource allocation, the designers are endowed with the freedom to allocate the capacities among different input channels with the total capacity of the communication network being given. When it comes to the case where sub-channels' capacities are assumed to be fixed static, a coding and controller co-design method is put forward in [30] to obtain the stabilizability condition for multi-input systems under signal-to-noise ratio constraint.

Linear quadratic (LQ) control has been possessing an indispensable role in systems and control theory. Such problem for deterministic systems has been extensively investigated, and reaches a mature state in the 1970s [31]. The optimal control problem for systems subjected to stochastic perturbations and network-induced constraints has equally received considerable attention from the control community. For example, [32] addresses the LQ control problem for networked control systems subjected to data rate constraints, where a state feedback control scheme is employed in order to achieve the minimum data rate for mean square stabilization of the system. To address the LQ problem for **Itô-type** stochastic systems with input delays, Wang and Zhang introduce a forward-backward stochastic differential equation based approach for obtaining the optimal controller [33]. [34] is concerned with the stochastic LQ control for Markovian jumping systems by using the averaging approach to **aggregate states** according to their jump rates. [35] studies the LQ performance of systems where control signals are subject to packet dropout, and both zero-control and hold strategies are discussed. Authors in [36] study the LQ control problem for discrete-time linear systems over single packet-dropping link and a controller-coding co-design method is proposed in order to deal with the lost packet, where estimates are used to replace the missing measurements.

To the best of authors' knowledge, the difficulties in designing NCSs mainly focus on the following aspects. First, analytical solution to controller synthesis of multi-input NCSs turns out to be an essential μ -synthesis problem [24, 28]. Second, controller synthesis problem with multiple coupled factors becomes significantly complicated and harder to cope with [22, 26]. Finally, it is usually a considerable and difficult problem to combine the proposed results with actual application requirements. Motivated by the above

discussion, in this paper, the stochastic LQ control under asymptotic tracking is considered for multi-input-multi-output (MIMO) discrete-time system with packet dropouts. Inspired by [30], a pair of linear encoder and decoder is introduced respectively in the transmitting side and the receiving side of the channels in order to take full advantage of the communication resource and achieve a better signal transmission. The sufficient conditions are deduced for co-designing of the controller and the coding matrices such that the tracking problem is solved and the stochastic LQ performance is guaranteed. Finally, a simulation with the implementation of the design method on two cooperative robots is included to show the effectiveness of the current results. The contributions of this paper are briefly discussed here. In the current tracking problem, multiple constraints as MIMO lossy channels, LQ performance requirement and coding strategy are investigated at same time under a unified framework. As mentioned previously, such multi-objective problem brings considerable difficulties during controller synthesis. This paper presents a complete solution to aforementioned problem. Moreover, different from the resource allocation technique reported in [24, 28, 29] where diagonal coding matrices are adopted, full dimensional coding matrices are applied here to achieve less conservative performance of the closed-loop system.

The remainder of the paper is organized as follows. Section 2 presents the problem formulation. Section 3 presents the main results of the considered control problem. The theoretical result is applied to cooperative robots in Section 4. The notation in this paper is fairly standard. The superscripts H and T are the complex conjugate transpose and transpose, respectively. In a symmetric matrix symbol $*$ denotes the symmetric terms. For a real square matrix P , $P \geq 0$ (respectively $P > 0$) means that P is symmetric positive semidefinite (respectively positive definite). The notation $E\{\cdot\}$, $\text{Tr}\{\cdot\}$, $\rho\{\cdot\}$, \otimes and \odot denote the standard expectation operator, trace of a square matrix, spectral radius, Kronecker product and Hadamard product, respectively. Moreover, $R\mathcal{H}_2$ stands for the space of all strictly proper and real rational stable matrices. For simplicity, a LTI system

$$\begin{cases} x(k+1) = Ax(k) + Bu(k), \\ y(k) = Cx(k) + Du(k), \end{cases}$$

is denoted by $G = (A, B, C, D)$. Given a transfer function $G(z) \in R\mathcal{H}_2$ with dimension $m \times m$, its \mathcal{H}_2 norm is defined as $\|G\|_2 = \sqrt{\frac{1}{2\pi} \int_{-\pi}^{\pi} \text{Tr}\{G(e^{j\omega})G^H(e^{j\omega})\} d\omega}$, and the mixed norm for $G(z)$ is defined as follows $\|G\|_{2,1} = \sqrt{\max_{1 \leq j \leq m} \sum_{i=1}^m \|G_{ij}(z)\|_2^2}$, where, $G_{ij}(z)$ denotes the element of $G(z)$ in i^{th} row and j^{th} column. For $G(z)$, the operator $\phi\{G(z)\}$ is defined as $\phi\{G(z)\} = \begin{bmatrix} \|G_{11}\|_2^2 & \cdots & \|G_{1m}\|_2^2 \\ \vdots & \ddots & \vdots \\ \|G_{m1}\|_2^2 & \cdots & \|G_{mm}\|_2^2 \end{bmatrix}$. The matrix 1-norm for $P \in \mathbb{C}^{m \times n}$ is defined as $\|P\|_1 = \max_{1 \leq j \leq m} \sum_{i=1}^n |P_{ij}|$. For simplicity, sometimes the arguments of a function will be omitted when no confusion can arise.

2 Problem formulation

The overall setup of the control problem is depicted in Fig. 1, where the controller connects to the discrete-time plant through encoder, multiple lossy channels and decoder.

The plant is described by the following discrete-time state-space representation:

$$\begin{cases} x(k+1) = Ax(k) + Bu(k), & x(0) = x_0, \\ z(k) = Cx(k) + Du(k), \end{cases} \quad (1)$$

where $x(k) \in \mathbb{R}^n$ is the state, $u(k) \in \mathbb{R}^m$ the control input, $z(k) \in \mathbb{R}^p$ the controlled output for tracking certain reference. Assume that the matrix pair (A, B) is stabilizable.

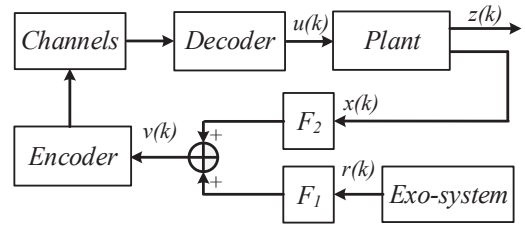

Fig. 1: System setup

The control law $v(k)$ is given by

$$v(k) = F_1 r(k) + F_2 x(k), \quad (2)$$

where $F_1 \in \mathbb{R}^{m \times q}$ is the feedforward gain related to the tracking reference and $F_2 \in \mathbb{R}^{m \times n}$ is the state feedback gain related to the LQ performance defined later, $r(k) \in \mathbb{R}^q$ is the state of the following exo-system:

$$\begin{cases} r(k+1) = A_r r(k), & r(0) = r_0, \\ z_r(k) = C_r r(k), \end{cases} \quad (3)$$

with $z_r(k) \in \mathbb{R}^p$ being the reference. It is known that the exo-system is an autonomous system that generates the reference signal to be tracked and the disturbance to be rejected. More detailed descriptions about exo-systems may be found in [37–39]. Hence, the tracking error can be defined as:

$$e(k) = z(k) - z_r(k). \quad (4)$$

Moreover, l unreliable channels are placed in the path from the controller to the plant. In some existing results, e.g., [28, 29], the number of channels is equal to the number of control signals, and the capacities of each sub-channels subject to certain lower bounds are assumed to be flexible under total capacity constraint. Instead, in this paper the capacity of each sub-channel is fixed a priori with an appropriate coding strategy to improve the efficiency of network resource. Therefore, different from the above works, the lower bounds of sub-channels' capacities are decreased, and relatively less expensive sub-channels may therefore be used. In this case, the number of channels is assumed to be more than the number of control signals, i.e. $l > m$.

Then, a pair of encoder $\mathcal{E} \in \mathbb{R}^{l \times m}$ and decoder $\mathcal{D} \in \mathbb{R}^{m \times l}$ is introduced on each side of the l channels to give a degree of freedom for fully utilizing the resource of all the multiple channels. This transmission process is specified by the input $v(k)$ and output $u(k)$ as

$$u(k) = \mathcal{D}\alpha(k)\mathcal{E}v(k), \quad (5)$$

where $\alpha(k) = \text{diag}[\alpha_1(k), \dots, \alpha_l(k)]$ with $\alpha_i(k)$, $i = 0, 1, \dots, l$ being Bernoulli variables to specify the unreliable transmission process of each channel. Here $\alpha_i(k)$ take value in $\{0, 1\}$ at any time instant k . $\alpha_i(k) = 1$ indicates that the transmission succeeds, otherwise $\alpha_i(k) = 0$. The probability of successful transmission is given as $E\{\alpha_i(k)\} = \beta_i$ with $\beta_i \in (0, 1)$. As known, encoder and decoder are generally viewed as a pair of invertible operators, hence the design requirement on \mathcal{E} and \mathcal{D} is to satisfy the following constraint:

$$\mathcal{D}\Xi\mathcal{E} = I, \quad (6)$$

where $\Xi = \text{diag}[\beta_1, \dots, \beta_l]$.

Combining (1), (3) and (5), the closed-loop system is obtained as:

$$\begin{aligned} x(k+1) &= [A + B\mathcal{D}\alpha(k)\mathcal{E}F_2]x(k) + B\mathcal{D}\alpha(k)\mathcal{E}F_1r(k), \\ e(k) &= [C + D\mathcal{D}\alpha(k)\mathcal{E}F_2]x(k) + [D\mathcal{D}\alpha(k)\mathcal{E}F_1 - C_r]r(k). \end{aligned} \quad (7)$$

Furthermore, we define the cost functional $J(x, u)$:

$$J(x, u) = \lim_{N \rightarrow \infty} \frac{1}{N} \sum_{k=0}^{N-1} \mathbb{E}\{x^T(k)Qx(k) + u^T(k)Ru(k)\}, \quad (8)$$

where the matrices $Q \geq$ and $R > 0$. And the following definition is introduced.

Definition 1. [14] The closed-loop system (7) is said to be mean square (MS) stable if for any bounded initial state $x(0)$ and $r(k) = 0$, $\lim_{k \rightarrow \infty} \mathbb{E}\{x(k)x^T(k)\} = 0$.

Now the problem under consideration is described as follows.

Problem 1. Find the feedforward gain F_1 , the feedback gain F_2 in (2) and a pair of encoder \mathcal{E} and decoder \mathcal{D} in (5) such that the closed-loop system (7) meets the following requirements:

- $\mathcal{R}1$ (MS stability): the closed-loop system (7) is MS stable;
- $\mathcal{R}2$ (LQ performance): the cost functional in (8) is minimized when $r(k) = 0$;
- $\mathcal{R}3$ (Tracking performance): for any bounded initial state $x(0)$, $r(0)$, the tracking error defined in (4) satisfies $\lim_{k \rightarrow \infty} \mathbb{E}\{e(k)\} = 0$.

Problem 1 is defined as a multi-objective control problem with the requirements detailed in $\mathcal{R}1$ - $\mathcal{R}3$. In the next section, corresponding solvability conditions are successively given to fulfill the aforementioned requirements, and based on them, a complete solution to Problem 1 is further presented.

3 Main results

3.1 MS stabilization

In this subsection, we are focused on MS stabilization. In other words, we consider Problem 1 with the requirements $\mathcal{R}2$ and $\mathcal{R}3$ being removed.

Theorem 1. $\mathcal{R}1$ in Problem 1 is satisfied, if there exist $U \in \mathbb{R}^{l \times m}$ with $U^T U = I$, $X > 0$, $W > 0$, and Y such that the following conditions hold

$$\left\{ U W U^T \right\}_{ii} < \frac{1}{\beta_i^{-1} - 1}, \quad (9)$$

$$\begin{bmatrix} W & Y \\ * & X \end{bmatrix} > 0, \quad (10)$$

$$\begin{bmatrix} X & AX + BY & B \\ * & X & 0 \\ * & * & I \end{bmatrix} > 0. \quad (11)$$

Then the state feedback gain F_2 in (2), encoder \mathcal{E} and decoder \mathcal{D} in (5) are constructed respectively as

$$F_2 = Y X^{-1}, \quad (12)$$

$$\mathcal{E} = \Xi^{-1/2} U, \quad \mathcal{D} = U^T \Xi^{-1/2}, \quad (13)$$

with $\Xi = \text{diag}[\beta_1, \dots, \beta_l]$.

The following lemmas are introduced here for the derivation of Theorem 1.

Lemma 1. [14] Given an internally stable system G with dimension $p \times p$ and a structured random process

$$\Delta(k) = \text{diag}[\Delta_1(k), \dots, \Delta_p(k)],$$

such that $\mathbb{E}\{\Delta_i(k)\} = 0$, $\mathbb{E}\{\Delta_i^2(k)\} = \tau_i^2$, $i = 1, 2, \dots, p$, then the feedback interconnection in Fig. 2 is MS stable if and only if the following condition holds $\rho\{\phi\{G\}\Phi\} < 1$, where $\Phi = \text{diag}[\tau_1^2, \dots, \tau_p^2]$.

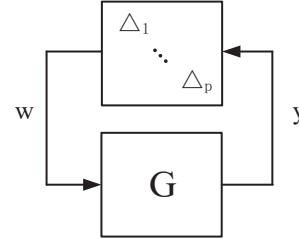

Fig. 2: System with stochastic perturbation

Lemma 2. Given an internally stable system G with dimension $p \times p$, there holds $\rho\{\phi\{G\}\} = \inf_{\mathcal{D}} \|\mathcal{D}^{-1} G \mathcal{D}\|_{2,1}^2$, where \mathcal{D} is a diagonal matrix with all diagonal elements being positive.

Proof: As represented by Lemma 2.2 in [40], for nonnegative matrix M , there holds

$$\rho\{M\} = \inf_{\mathcal{D}} \|\mathcal{D}^{-1} M \mathcal{D}\|_p,$$

for $1 \leq p \leq \infty$. Thus, there holds

$$\rho\{\phi(G)\} = \inf_{\mathcal{D}} \|\mathcal{D}^{-1} \phi(G) \mathcal{D}\|_1,$$

and by the definition of $\|\cdot\|_{2,1}$, there holds

$$\|\mathcal{D}^{-1} \phi(G) \mathcal{D}\|_1 = \|\mathcal{D}^{-1} G \mathcal{D}\|_{2,1}^2.$$

Then it is observed that

$$\rho\{\phi(G)\} = \inf_{\mathcal{D}} \|\mathcal{D}^{-1} G \mathcal{D}\|_{2,1}^2. \quad \square$$

Now, we are in the position to prove Theorem 1.

Proof of Theorem 1:

Note that for the Bernoulli process $\alpha_i(k)$ mentioned in (5), $i = 1, 2, \dots, l$, we have

$$\mathbb{E}\{\alpha_i(k)\} = \beta_i \neq 0, \quad \mathbb{E}\{(\alpha_i(k) - \beta_i)^2\} = \beta_i(1 - \beta_i).$$

Setting new random variables as $\phi_i(k) = [\alpha_i(k) - \beta_i]/\beta_i$, yields

$$\mathbb{E}\{\phi_i(k)\} = 0, \quad \mathbb{E}\{\phi_i^2(k)\} = \beta_i^{-1} - 1,$$

$i = 1, 2, \dots, l$. Then the closed-loop system in (7) is rewritten as

$$x(k+1) = (A + B F_2 + B \mathcal{D} \Xi \Phi(k) \mathcal{E} F_2) x(k),$$

where $\Xi = \text{diag}[\beta_1, \dots, \beta_l]$, $\Phi(k) = \text{diag}[\phi_1(k), \dots, \phi_l(k)]$.

The above closed-loop system can be rewritten as:

$$\begin{aligned} x(k+1) &= (A + BF_2)x(k) + B\mathcal{D}\Xi w(k), \\ y(k) &= \mathcal{E}F_2x(k), \\ w(k) &= \Phi(k)y(k). \end{aligned}$$

Then it can be seen as the interconnection of two parts in Fig. 2 with

$$G = (A + BF_2, B\mathcal{D}\Xi, \mathcal{E}F_2, 0), \Delta(k) = \Phi(k),$$

where the system G is stable with (11) holding.

With the help of Lemma 1, it is easy to indicate that the closed-loop system (7) is MS stable if there exists a feedback gain F_2 , an encoder/decoder pair \mathcal{E} and \mathcal{D} such that

$$\rho\{\tilde{T}\tilde{\beta}^2\} < 1 \quad (14)$$

where $\tilde{T} = \phi(T(z))$, $T(z) = \mathcal{E}F_2(zI - A - BF_2)^{-1}B\mathcal{D}\Xi$, $\tilde{\beta} = \text{diag}[(\beta_1^{-1} - 1)^{\frac{1}{2}}, \dots, (\beta_l^{-1} - 1)^{\frac{1}{2}}]$.

Next, we will show that under the conditions (9)-(11), (14) holds with F_2 , \mathcal{E} and \mathcal{D} given in (12) and (13). To this end, $T(z)$ is first rewritten as

$$T(z) = \Xi^{-1/2}UF_2(zI - A - BF_2)^{-1}BU^T\Xi^{1/2}.$$

Then, it is observed by Lemma 2 that

$$\rho\{\tilde{T}\tilde{\beta}^2\} = \inf_{\mathcal{D}} \left\| \mathcal{D}^{-1}T(z)\tilde{\beta}\mathcal{D} \right\|_{2,1}^2.$$

Next, we will show

$$\rho\{\tilde{T}\tilde{\beta}^2\} \leq \left\| \mathcal{D}^{-1}T(z)\tilde{\beta}\mathcal{D} \right\|_{2,1}^2 < 1,$$

with \mathcal{D} being selected as $\mathcal{D} = \Xi^{-1/2}$.

By the definition, $\left\| \Xi^{1/2}T(z)\tilde{\beta}\Xi^{-1/2} \right\|_{2,1}^2$ can be rewritten as

$$\begin{aligned} & \left\| \Xi^{1/2}T(z)\tilde{\beta}\Xi^{-1/2} \right\|_{2,1}^2 \\ &= \max_i \frac{1}{2\pi} \int_{-\pi}^{\pi} \left\{ \tilde{\beta}\Xi^{-1/2}T^H(e^{jw})\Xi_l T(e^{jw})\Xi_l^{-1/2}\tilde{\beta} \right\}_{ii} dw \\ &= \max_i \left\{ \tilde{\beta}U \left(\frac{1}{2\pi} \int_{-\pi}^{\pi} \tilde{T}^H(e^{jw})\tilde{T}(e^{jw})dw \right) U^T\tilde{\beta} \right\}_{ii}. \end{aligned}$$

where $\tilde{T}(z) = F_2(zI - A - BF_2)B$ satisfying

$$\frac{1}{2\pi} \int_{-\pi}^{\pi} \tilde{T}^H(e^{jw})\tilde{T}(e^{jw})dw = F_2^T W_0 F_2$$

with W_0 being the solution to equation

$$(A + BF_2)^T W_0 (A + BF_2) - W_0 + BB^T = 0. \quad (15)$$

By Schur complement, (11) and (12) indicate that

$$(A + BF_2)^T X (A + BF_2) - X + BB^T < 0,$$

and (10) and (12) indicate that

$$W > F_2^T X F_2.$$

According to III. C in [41], it can be concluded that

$$W > F_2^T X F_2 > F_2^T W_0 F_2 = \frac{1}{2\pi} \int_{-\pi}^{\pi} \tilde{T}^H(e^{jw})\tilde{T}(e^{jw})dw.$$

Therefore, it can be concluded with (9) that

$$\begin{aligned} & \left\| \Xi^{1/2}T(z)\tilde{\beta}\Xi^{-1/2} \right\|_{2,1}^2 \\ &= \max_i \left\{ \tilde{\beta}U \left(\frac{1}{2\pi} \int_{-\pi}^{\pi} \tilde{T}^H(e^{jw})\tilde{T}(e^{jw})dw \right) U^T\tilde{\beta} \right\}_{ii} \\ &< \max_i \left\{ \tilde{\beta}U(W)U^T\tilde{\beta} \right\}_{ii} \\ &< 1. \end{aligned}$$

Then, it is clear that

$$\rho\{\tilde{T}\tilde{\beta}^2\} \leq \left\| \Xi^{1/2}T(z)\tilde{\beta}\Xi^{-1/2} \right\|_{2,1}^2 < 1.$$

Consequently, (14) holds. Therefore, the closed-loop system (7) is MS stable. \square

It can be seen from the proof that the controller synthesis problem of multi-input NCSs with packet dropout turns out to be a μ problem. Compared with the resource allocation technique appeared in [24, 28, 29], where diagonal coding matrices are adopted, full dimensional coding matrices are applied here to achieve less conservative performance. However, the solvability conditions (9)-(11) given in Theorem 1 result in a nonlinear matrix inequality problem. One can of course take a specific U to render the problem convex. However, proceeding with a specific U may lead to a conservative synthesis. Therefore, an iterative algorithm for finding a less conservative solution will be given in the subsection 3. 3.

3.2 Linear quadratic MS stabilization

In this subsection, we are concerned with LQ performance under MS stability, that is, Problem 1 with the requirement $\mathcal{R}3$ being removed.

Before proceeding, we rewrite the closed-loop system (7) with $r(k)$ been removed as

$$x(k+1) = Ax(k) + B\mathcal{D}\Xi[I + \Phi(k)]\mathcal{E}F_2x(k), \quad (16)$$

where $\Phi(k) = \text{diag}[\phi_1(k), \dots, \phi_l(k)]$, $\phi_i(k) = [\alpha_i(k) - \beta_i]/\beta_i$, $i = 1, 2, \dots, l$. And the control law $v(k)$ is rewritten as

$$v(k) = F_2x(k).$$

Theorem 2. $\mathcal{R}1$ and $\mathcal{R}2$ in Problem 1 are satisfied if there exist solution $P > 0$ and $U \in \mathbb{R}^{l \times m}$ with $U^T U = I$ to the following modified discrete-time algebraic Riccati equation (MDARE)

$$P = A^T P A + Q - A^T P B U^T \Xi^{\frac{1}{2}} \bar{\Sigma}^{-1} \Xi^{\frac{1}{2}} U B^T P A, \quad (17)$$

where

$$\bar{\Sigma} = [(\Xi \mathcal{H} \Xi + \Sigma) \odot (R + \Xi^{\frac{1}{2}} U B^T P B U^T \Xi^{\frac{1}{2}})],$$

$$\Sigma = \text{diag}[\beta_1(1 - \beta_1), \dots, \beta_l(1 - \beta_l)],$$

$$\Xi = \text{diag}[\beta_1, \dots, \beta_l],$$

\mathcal{H} denotes a constant matrix with all elements being 1. Then the feedback gain F_2 is given by

$$F_2 = -U^T \Xi^{\frac{1}{2}} \bar{\Sigma}^{-1} \Xi^{\frac{1}{2}} U B^T P A, \quad (18)$$

the encoder and decoder are given as

$$\mathcal{E} = \Xi^{-1/2}U, \quad \mathcal{D} = U^T \Xi^{-1/2}. \quad (19)$$

Proof: First let us consider the MS stability of the closed-loop system (7) with the feedback gain F_2 given in (18), encoder \mathcal{E} and decoder \mathcal{D} given in (19). To this end, we define

$$V[x(k)] = \text{Tr}\{\mathbb{E}\{x(k)x^T(k)\}P\}.$$

For the closed-loop system

$$x(k+1) = Ax(k) + B\mathcal{D}\Xi[I + \Phi(k)]\mathcal{E}F_2x(k),$$

it can be concluded that

$$\begin{aligned} & V[x(k+1)] \\ &= \text{Tr}\{\mathbb{E}\{x(k+1)x^T(k+1)\}P\} \\ &= \text{Tr}\{\mathbb{E}\{x(k)x^T(k)[(A + B\mathcal{D}\Xi\mathcal{E}F_2)^T P(A + B\mathcal{D}\Xi\mathcal{E}F_2)]\} \\ &\quad + \text{Tr}\{\mathbb{E}\{x(k)x^T(k)[(B\mathcal{D}\Xi\Phi(k)\mathcal{E}F_2)^T P(B\mathcal{D}\Xi\Phi(k)\mathcal{E}F_2)]\}\} \\ &= \text{Tr}\{\mathbb{E}\{x(k)x^T(k)\}A^T P A\} \\ &\quad + \text{Tr}\{\mathbb{E}\{x(k)x^T(k)\}[(\mathcal{E}F_2)^T \hat{\Sigma}^{-1}(\mathcal{E}F_2)]\}, \end{aligned}$$

where $\hat{\Sigma} = [(\Xi\mathcal{H}\Xi + \Sigma) \odot (\Xi^{\frac{1}{2}}UB^T PBU^T \Xi^{\frac{1}{2}})]$.

Substituting (17), (18) and (19) into the above formula, yields

$$\begin{aligned} & V[x(k+1)] \\ &= V[x(k)] - \text{Tr}\{\mathbb{E}\{x(k)x^T(k)\}Q\} \\ &\quad - \text{Tr}\{\mathbb{E}\{x(k)x^T(k)\}[(\mathcal{E}F_2)^T [(\Xi\mathcal{H}\Xi + \Sigma) \odot R]^{-1}(\mathcal{E}F_2)]\} \\ &< V[x(k)]. \end{aligned}$$

Therefore, $\lim_{k \rightarrow \infty} \mathbb{E}\{x(k)x^T(k)\} = 0$, which indicates that the closed-loop system (7) is MS stable.

For further considering the functional $J(x, u)$ in (8), we define

$$V_1[x(k)] = x^T(k)Px(k),$$

$$z_1(k) = \begin{bmatrix} Q^{\frac{1}{2}}x(k) \\ R^{\frac{1}{2}}u(k) \end{bmatrix}.$$

Noticing

$$z_1(k) = \begin{bmatrix} Q^{\frac{1}{2}}x(k) \\ R^{\frac{1}{2}}\mathcal{D}\Xi[I + \Phi(k)]\mathcal{E}F_2x(k) \end{bmatrix},$$

there holds

$$\begin{aligned} & \|z_1(k)\|^2 + V_1(k+1) - V_1(k) \\ &= x^T(k)Qx(k) + v^T(k)\mathcal{E}^T \Xi \mathcal{D}^T R \mathcal{D} \Xi \mathcal{E} v(k) \\ &\quad + v^T(k)\Phi(k)\mathcal{E}^T \Xi \mathcal{D}^T R \mathcal{D} \Xi \mathcal{E} \Phi(k)v(k) \\ &\quad + 2v^T(k)\mathcal{E}^T \Xi \mathcal{D}^T R \mathcal{D} \Xi \mathcal{E} \Phi(k)v(k) \\ &\quad + x^T(k)A^T P A x(k) + v^T(k)\mathcal{E}^T \Xi \mathcal{D}^T B^T P B \mathcal{D} \Xi \mathcal{E} v(k) \\ &\quad + v^T(k)\Phi(k)\mathcal{E}^T \Xi \mathcal{D}^T B^T P B \mathcal{D} \Xi \mathcal{E} \Phi(k)v(k) \\ &\quad + 2x^T(k)A^T P B \mathcal{D} \Xi \mathcal{E} v(k) + 2x^T(k)A^T P B \mathcal{D} \Xi \mathcal{E} \Phi(k)v(k) \\ &\quad + 2v^T(k)\mathcal{E}^T \Xi \mathcal{D}^T B^T P B \mathcal{D} \Xi \mathcal{E} \Phi(k)v(k) - x^T(k)Px(k). \end{aligned}$$

Note that the random variable $\Phi(k)$ is independent of the control law $v(k)$, which is a static linear function of the state $x(k)$. Hence,

taking expectations from both sides, together with (17), yields

$$\begin{aligned} & \mathbb{E}\{\|z_1(k)\|^2\} + \mathbb{E}\{V_1(k+1)\} - \mathbb{E}\{V_1(k)\} \\ &= \mathbb{E}\{(\mathcal{E}F_2x(k))^T \bar{\Sigma} \mathcal{E}F_2x(k)\} \\ &\quad + \mathbb{E}\{x^T(k)[A^T P B U^T \Xi^{\frac{1}{2}} \bar{\Sigma}^{-1} \Xi^{\frac{1}{2}} U B^T P A]x(k)\} \\ &\quad + \mathbb{E}\{2x^T(k)[A^T P B U^T \Xi^{\frac{1}{2}}] \mathcal{E}F_2x(k)\}. \end{aligned}$$

where $\bar{\Sigma} = [(\Xi\mathcal{H}\Xi + \Sigma) \odot (R + \Xi^{\frac{1}{2}}UB^T PBU^T \Xi^{\frac{1}{2}})]$. There holds

$$\begin{aligned} & J(x, u) \\ &= \mathbb{E}\{\|z_1(k)\|^2\} \\ &= \lim_{N \rightarrow \infty} \frac{1}{N} \sum_{k=0}^{N-1} \mathbb{E}[x^T(k)Qx(k) + u^T(k)Ru(k)] \\ &= \left\| \bar{\Sigma}^{\frac{1}{2}} [\mathcal{E}F_2 + \bar{\Sigma}^{-1} \Xi^{\frac{1}{2}} U B^T P A] x \right\|_{\epsilon}^2 + x_0^T P x_0. \end{aligned}$$

It is easy to conclude that $J(x, u)$ is minimized if

$$\mathcal{E}F_2 = -\bar{\Sigma}^{-1} \Xi^{\frac{1}{2}} U B^T P A.$$

Noticing that $\mathcal{D}\Xi\mathcal{E} = I$, $\mathcal{E} = \Xi^{-1/2}U$ and $\mathcal{D} = U^T \Xi^{-1/2}$, multiply $\mathcal{D}\Xi$ at both sides of the above equation and the state feedback gain F_2 is given by $F_2 = -U^T \Xi^{\frac{1}{2}} \bar{\Sigma}^{-1} \Xi^{\frac{1}{2}} U B^T P A$. \square

The MDARE (17) in Theorem 2 is solvable, if the closed-loop system (7) is MS stabilizable via state feedback [29, 42]. It is well known that solving modified Riccati equation in the stochastic setting with close-form solution is still an open problem [29, 42]. To be worse, the MDARE (17) also includes the matrix U , which makes the corresponding solvability condition even harder. In Algorithm 1, we propose an iterative method for numerical solution to MDARE (17) with a fixed U matrix.

Algorithm 1

Step 1: give the number of iteration N_1 . Set $k = 0$ and the initial condition $P(0) = 0$.

Step 2: solve conditions (9)-(11) and obtain a feasible matrix U .

Step 3: update $P(k)$ as

$$P(k+1) = A^T P(k)A + Q - A^T P B U^T \Xi^{\frac{1}{2}} \bar{\Sigma}^{-1} \Xi^{\frac{1}{2}} U B^T P A,$$

with $\bar{\Sigma} = [(\Xi\mathcal{H}\Xi + \Sigma) \odot (R + \Xi^{-\frac{1}{2}}UB^T PBU^T \Xi^{\frac{1}{2}})]$.

Step 4: set $k = k + 1$, go to Steps 3. If $\|P_{k+1} - P_k\| < \epsilon$ with ϵ being a small positive number, stop. If $k > N_1$, stop.

3.3 Additional asymptotic tracking

In this subsection, a sufficient condition is given for designing the feedforward gain F_1 in (2) such that the tracking requirement \mathcal{R}_3 defined in Problem 1 is fulfilled.

Theorem 3. $\mathcal{R}3$ in Problem 1 is satisfied if there exist matrices X_r and Y_r such that the following Sylvester equation holds:

$$\begin{aligned} X_r A_r &= A X_r + B Y_r, \\ 0 &= C X_r + D Y_r - C_r. \end{aligned} \quad (20)$$

Moreover, the feedforward gain F_1 is given as:

$$F_1 = Y_r - F_2 X_r, \quad (21)$$

where F_2 is any feedback gain that ensures the MS stability of the closed-loop system (7).

Proof: Substitute (21) into (20), yields

$$\begin{aligned} X_r A_r &= (A + B F_2) X_r + B F_1, \\ 0 &= (C + D F_2) X_r + D F_1 - C_r. \end{aligned} \quad (22)$$

By defining $\bar{x}(k) = x(k) - X_r r(k)$ for the closed-loop system (7), it is observed that

$$\begin{aligned} &x(k+1) - X_r r(k+1) \\ &= A_c x(k) + B_c r(k) - X_r r(k+1) \\ &= (A + B F_2) x(k) + B F_1 r(k) + B \mathcal{D} \Xi \Phi(k) \mathcal{E} F_2 x(k) \\ &\quad + B \mathcal{D} \Xi \Phi(k) \mathcal{E} F_1 r(k) - X_r A_r r(k), \end{aligned}$$

where $A_c = A + B \mathcal{D} \alpha(k) \mathcal{E} F_2$, $B_c = B \mathcal{D} \alpha(k) \mathcal{E} F_1$.

Substituting (21) and (22) into the above formula, yields

$$\begin{aligned} &\bar{x}(k+1) \\ &= x(k+1) - X_r r(k+1) \\ &= (A + B F_2)(x(k) - X_r r(k)) + B \mathcal{D} \Xi \Phi(k) \mathcal{E} F_2 x(k) \\ &\quad + B \mathcal{D} \Xi \Phi(k) \mathcal{E} F_1 r(k) \\ &= (A + B \mathcal{D} \alpha(k) \mathcal{E} F_2) \bar{x}(k) + (B \mathcal{D} \Xi \Phi(k) \mathcal{E} Y_r) r(k). \end{aligned}$$

Note that $\mathbb{E}\{B \mathcal{D} \Xi \Phi(k) \mathcal{E} Y_r\} r(k) = 0$, then $\lim_{k \rightarrow \infty} \mathbb{E}[\bar{x}(k)] = 0$.

According to (6) and $e(k)$ defined in (7)

$$\begin{aligned} &\lim_{k \rightarrow \infty} \mathbb{E}[e(k)] \\ &= \lim_{k \rightarrow \infty} \mathbb{E}[(C + D \mathcal{D} \alpha(k) \mathcal{E} F_2) x(k) + (-C_r + D \mathcal{D} \alpha(k) \mathcal{E} F_1) r(k)] \\ &= \lim_{k \rightarrow \infty} \mathbb{E}[(C + D F_2) x(k) + (-C_r + D F_1) r(k)]. \end{aligned}$$

By defining $\bar{x}(k) = x(k) - X_r r(k)$,

$$\begin{aligned} \lim_{k \rightarrow \infty} \mathbb{E}[e(k)] &= \lim_{k \rightarrow \infty} \mathbb{E}[(C + D F_2) x(k) - (C + D F_2) X_r r(k) \\ &\quad + (C + D F_2) X_r r(k) + (-C_r + D F_1) r(k)] \\ &= \lim_{k \rightarrow \infty} \mathbb{E}[(C + D F_2) \bar{x}(k)] \\ &\quad + \lim_{k \rightarrow \infty} \mathbb{E}[(C X_r + D F_2 X_r + D F_1 - C_r) r(k)]. \end{aligned}$$

Note that $\lim_{k \rightarrow \infty} \mathbb{E}[\bar{x}(k)] = 0$ and

$$C X_r + D F_2 X_r + D F_1 - C_r = 0$$

according to (22). Thus, $\lim_{k \rightarrow \infty} \mathbb{E}[e(k)] = 0$ and the tracking requirement $\mathcal{R}3$ in Problem 1 is satisfied. \square

Theorem 3 presents the condition for satisfying the requirement $\mathcal{R}3$ in Problem 1. The corresponding feedforward gain F_1 given in

(21) is structured with X_r , Y_r and F_2 , among which F_2 is the feedback gain related to MS stability of the closed-loop system (7) and can be previously computed by Theorem 1 or Theorem 2. So far, all the conditions needed to solve the Problem 1 have already been presented. Therefore, the following complete condition is given for solving the Problem 1.

Theorem 4. The Problem 1 is solvable if there exist matrices $U \in \mathbb{R}^{l \times m}$ satisfying $U^T U = I$, $X > 0$, $W > 0$, Y , $P > 0$, X_r , Y_r , such that the conditions (9)-(11), (17) and (20) hold. Then the feedforward gain F_1 is given in (21), the feedback gain F_2 is given in (18), the encoder \mathcal{E} and decoder \mathcal{D} are given in (19).

Proof: The proof can be obviously obtained by combination of Theorem 1, Theorem 2 and Theorem 3. \square

Theorem 4 is a synthesis of Theorem 1-3, which gives a complete solution to Problem 1. In other words, the controller obtained by Theorem 4 can achieve minimum LQ performance under MS stabilization when $r(k) = 0$. At the same time, when $r(k) \neq 0$, it can also fulfill asymptotic tracking for reference generated by $r(k)$.

In the section 3.2, a simple and efficient Algorithm 1 is provided to solve the MDARE (17) provided in Theorem 2. However, the certain solution of MDARE (17) by directly applying a specific U matrix may lead to a conservative synthesis. Therefore, an iterative process taking benefits from Theorems 1 and Theorems 2 is proposed in this subsection to design iteratively the matrix U and feedback gain F_2 in order to reduce the conservatism of the results.

Algorithm 2

Step 1: give the number of iteration N_1 . Set $i = 0$, $k = 0$. Get a feasible U by solving inequalities (9)-(11).

Step 2: compute MDARE (17) with U in Step 1 by Algorithm 1 and structure the feedback gain F_2 as in (18).

Step 3: calculate W_i by solving equation (15) with F_2 in Step 2 and set $W = W_i$.

Step 4: find $U = U(0), U(1), \dots, U(N)$ satisfying (9) with W in Step 3 and set $c = 0$, $j = 0$, $P(0) = 0$. If $N = 0$, stop.

Step 5: update $P(k)$ as Step 3 in Algorithm 1 with $U = U(c)$.

Step 6: set $k = k + 1$, and go to Step 5. If $|P(k+1) - P(k)| < \epsilon$ with ϵ being a small positive number, set $P_j = P(k+1)$, $U_j = U(c)$, $j = j + 1$, $c = c + 1$, $k = 0$ and go to Step 5. If $k > N_1$, set $k = 0$, $c = c + 1$ and go to Step 5. If $c = N$, go to Step 7.

Step 7: find the matrix P_{j^*} that minimizing $x^T(0) P_{j^*} x(0)$, where $j^* = 1, 2, \dots, j$ and set $P_i = P_{j^*}$, $U_i = U_{j^*}$.

Step 8: if $\|x^T(0)(P_i - P_{i-1})x(0)\| < \epsilon$ with ϵ being a small positive number, obtain the feedback gain F_2 with $P = P_i$, $U = U_i$ as in (18), stop.

Step 9: set $i = i + 1$, go to Step 3.

4 Application

In this section, the main results proposed in section 3 is applied to a cooperative control platform with two robots to show the specific co-design process and to verify the effectiveness of the results.

4.1 Platform description

As depicted in Fig. 3, the control platform consists of two cooperative mobile robots, one camera and a supervisor. The objective of this platform is to drive the two cooperative tank-like mobile robots in order to complete tasks such as manipulating a load too cumbersome and heavy for only one of the robots. The supervisor can measure the absolute position and velocity of each robot thanks to cameras without delays and communicate control signals to each robot through a wireless protocol.

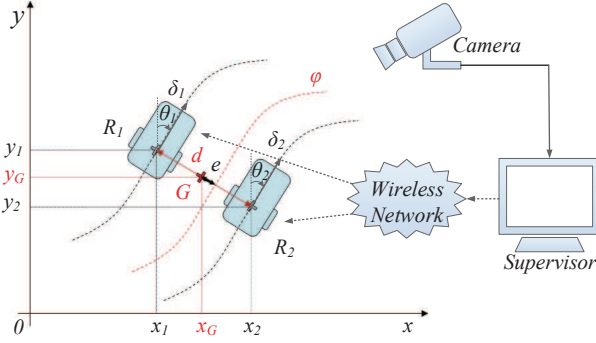

Fig. 3: Setup of the cooperative control platform

The control objectives for the platform depicted in Fig. 3 can be formulated as follows:

- The barycenter $G(x_G; y_G)$ of the two robots must be driven along a pre-defined path.
- A constant interdistance d between the two robots must be ensured. The interdistance d is defined here as the euclidian norm between centers of *robot1* $(x_1; y_1)$ and *robot2* $(x_2; y_2)$ as

$$\begin{cases} x_G = (x_1 + x_2)/2, \\ y_G = (y_1 + y_2)/2, \\ d = \sqrt{(x_1 - x_2)^2 + (y_1 - y_2)^2}. \end{cases} \quad (23)$$

To feet with (23), the control objectives can be defined through the 4 following signals to be controlled

$$\begin{cases} x_G = (x_1 + x_2)/2, \\ y_G = (y_1 + y_2)/2, \\ \Delta_x = x_1 - x_2, \\ \Delta_y = y_1 - y_2. \end{cases}$$

The reference trajectory can be generated directly by a human joystick by using some robotic trajectory generation algorithms, etc. The trajectory generator provides a vector signal \mathcal{X} as:

$$\mathcal{X}(k) = [x_G^{ref}(k) \ y_G^{ref}(k) \ \Delta_x^{ref}(k) \ \Delta_y^{ref}(k)]^T$$

4.2 Control strategy formulation

The whole control implementation is depicted in Fig. 4. The two robots with their local feedback linearization law are set as the plant. The camera send the measured absolute position and velocity of each robot to the supervisor with a sampling period tuned at 0.1s. The controller implemented by the supervisor consists of a static feedback gain F_2 and a static feedforward gain F_1 generating the control signals v_1, v_2, v_3 and v_4 to drive the two robots.

The four control signals v_1, v_2, v_3 and v_4 are firstly encoded and then transmitted via $l = 6$ independent wireless lossy channels. After transmission, the signals are decoded and sent to the two robots, respectively. The encoder (static matrix $\mathcal{E} \in \mathbb{R}^{6 \times 4}$) can

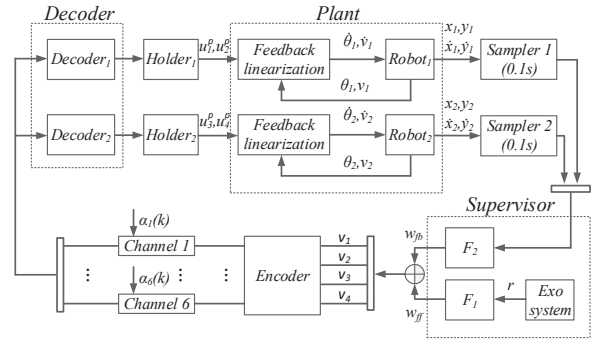

Fig. 4: Control implementation for the robots platform

be implemented directly in the supervisor, or locally in the hardware transmitter. The decoder (static matrix $\mathcal{D} \in \mathbb{R}^{4 \times 6}$) should be implemented separately in the two robots as following eq. (24).

$$\mathcal{D} = \begin{bmatrix} \mathcal{D}_1 \\ \mathcal{D}_2 \end{bmatrix}, \mathcal{D}_1 \in \mathbb{R}^{2 \times 6}, \mathcal{D}_2 \in \mathbb{R}^{2 \times 6}. \quad (24)$$

Each robot can be modeled by a classic kinematic unicycle model

$$\begin{cases} \dot{x}_i = \delta_i \cos(\theta_i), \\ \dot{y}_i = \delta_i \sin(\theta_i), \\ \dot{\theta}_i = \eta_i, \\ \dot{\delta}_i = \gamma_i. \end{cases}$$

where $(x_i; y_i)$ are the position of the *robot_i*, δ_i and θ_i its velocity and its angular orientation, $(\dot{x}_i; \dot{y}_i)$ its velocity on (O_x) and (O_y) axle in the frame (O, x, y) , $\dot{\theta}_i$ its angular velocity, η_i, γ_i the plant input of the robot $i, i = 1, 2$. In each robot a classical linearizing feedback control law is implemented [43], leading to a new input-output mapping (see Fig. 3) based on two decoupled integrator chains.

$$Rob_i^{lin} = \begin{cases} x_i/a_i^x = 1/s^2, \\ y_i/a_i^y = 1/s^2. \end{cases}$$

The two new control inputs for each robots $(a_i^x; a_i^y)$ are homogeneous to the acceleration of the robot. Finally, without taking into consideration the decoder \mathcal{D}_i embedded in each robot, the plant model, after exact discretization at $T_{samp} = 0.1s$, is given by

$$\dot{x}_p = A_p x_p + B_p u_p, \quad (25)$$

with

$$\begin{aligned} x_p^T &= [x_1 \ \dot{x}_1 \ y_1 \ \dot{y}_1 \ x_2 \ \dot{x}_2 \ y_2 \ \dot{y}_2]^T, \\ u_p^T &= [u_1^p \ u_2^p \ u_3^p \ u_4^p]^T = [a_1^x \ a_1^y \ a_2^x \ a_2^y]^T, \\ A_p &= \text{diag}[A_1, \dots, A_4], \ B_p = \text{diag}[b_1, \dots, b_4], \\ A_i &= \begin{bmatrix} 1 & 0.1 \\ 0 & 1 \end{bmatrix}, \ b_i = \begin{bmatrix} 0.005 \\ 0.100 \end{bmatrix}, \ i = 1, 2, 3, 4. \end{aligned}$$

Such sampling period T_{samp} leads to a good compromise between the dynamic of the robots, and the capacities of the supervisor (video tracking algorithm in particular) and of the wireless protocol (e.g. Zigbee or Bluetooth).

The standard model defined in (1) is linked to the discretize plant model (25), and the matrices for the output regulation problem are

defined as

$$A = A_p, B = B_p,$$

$$C = \begin{bmatrix} 0.5 & 0 & 0 & 0 & 0.5 & 0 & 0 & 0 \\ 0 & 0 & 0.5 & 0 & 0 & 0 & 0.5 & 0 \\ 1 & 0 & 0 & 0 & -1 & 0 & 0 & 0 \\ 0 & 0 & 1 & 0 & 0 & 0 & -1 & 0 \end{bmatrix}, D = 0.$$

4.3 Trajectory tracking problem formulation

The trajectory tracking problem is considered here and it is reformulated to fit with the theoretical results proposed in this paper.

In this simulation, the reference trajectory $z_r(k)$ for the gravity center G is a circle with radius 10 meters, and the robots should travel around this trajectory with a fixed interdistance of 2m, at a fixed velocity of 1m/s. The travel period is thus around 62.8s. This leads in discrete-time to

$$z_r(k) = C_r r(k) = \begin{cases} x_G^r(k) = 10\sin(0.1\pi k/20), \\ y_G^r(k) = 10\cos(0.1\pi k/20), \\ \Delta_x^r(k) = 2\sin(0.1\pi k/20), \\ \Delta_y^r(k) = 2\cos(0.1\pi k/20). \end{cases} \quad (26)$$

The 4 reference signals are clearly coupled, thus a discrete-time state-space representation based on (3) can be designed with parameters

$$A_r = \begin{bmatrix} 0.99995 & -0.00800 \\ 0.01250 & 0.99995 \end{bmatrix}, C_r = \begin{bmatrix} 0 & 10 & 0 & 2 \\ 8 & 0 & -1.6 & 0 \end{bmatrix}^T.$$

4.4 Numerical results

In this subsection, some Matlab simulations are considered for the above mentioned platform. The robots with their local feedback linearization are modeled according to (25). The MIMO channels is modeled with data arrival rates $\beta_1 = 0.9, \beta_2 = 0.7, \beta_3 = 0.5, \beta_4 = 0.5, \beta_5 = 0.3, \beta_6 = 0.1$.

To feet with the theoretical results proposed in section 3, three different control strategies are considered for the robots platform in this subsection:

- 1. the controller set ($F_2 = F_2^{MS}, U = U^{MS}, F_1 = F_1^{MS}$) is obtained thanks to Theorem 1 and Theorem 3 without considering the LQ performance requirement $\mathcal{R}2$;
- 2. the set ($F_2 = F_2^{LQ1}, U = U^{LQ1}, F_1 = F_1^{LQ1}$) and ($F_2 = F_2^{LQ2}, U = U^{LQ2}, F_1 = F_1^{LQ2}$) corresponding to two different weighting parameters for LQ functional (8) are obtained by Theorem 4 with a specific U ;
- 3. the sets ($F_2 = F_2^{IT1}, U = U^{IT1}, F_1 = F_1^{IT1}$), ($F_2 = F_2^{IT2}, U = U^{IT2}, F_1 = F_1^{IT2}$) are obtained by solving Theorem 4 with different weighting parameters for LQ functional (8), and the iterative design method proposed in Algorithm 2 is adopted to reduce the conservatism of the results.

MS stabilization

In this part, the MS stabilization feedback gain $F_2 = F_2^{MS}$ is designed for the cooperative robots platform by Theorem 1 without considering the LQ performance, and the corresponding feedforward gain $F_1 = F_1^{MS}$ is computed by Theorem 3. With F_2^{MS} and F_1^{MS} , a simulation is introduced to show the tracking performance of the cooperative robots.

For Theorem 1, the matrix U^{MS} is given as:

$$U^{MS} = \begin{bmatrix} -0.2823 & -0.4024 & -0.5113 & -0.2098 \\ -0.4515 & -0.1390 & 0.5950 & 0.3477 \\ -0.6033 & -0.0440 & 0.2043 & -0.0217 \\ -0.3672 & 0.7786 & -0.3976 & 0.2797 \\ -0.4164 & -0.3496 & -0.3614 & -0.0106 \\ -0.2103 & 0.2973 & 0.2327 & -0.8696 \end{bmatrix}.$$

Then the feedback gain F_2^{MS} associated to the matrix U^{MS} is obtained by solving (9)-(11) as:

$$F_2^{MS} = \text{diag}[f_1, \dots, f_4],$$

with

$$f_1 = f_2 = f_3 = f_4 = [-0.3397 \quad -1.1151].$$

The feedforward gain F_1^{MS} corresponding to F_2^{MS} and U^{MS} is obtained by Theorem 3 as:

$$F_1^{MS} = \begin{bmatrix} 1.2341 & 2.9099 \\ 3.6374 & -0.9873 \\ 1.0097 & 2.3808 \\ 2.9761 & -0.8078 \end{bmatrix}.$$

For the simulation, a unit step signal $w(t)$ is added to the position of robot 1 (state x_1 in (25)) from time 30s to 42s to simulate some kind of disturbance factors. The initial positions of robot 1 and robot 2 are (0, 11) and (0, 9) respectively, and the two robots are asked to follow a circular trajectory with diameter 10m, a inter-distance of 2 meters and a fixed velocity 1m/s.

Based on F_2^{MS}, U^{MS} and F_1^{MS} , Fig. 5 shows the tracking performance and the evolution of the tracking error.

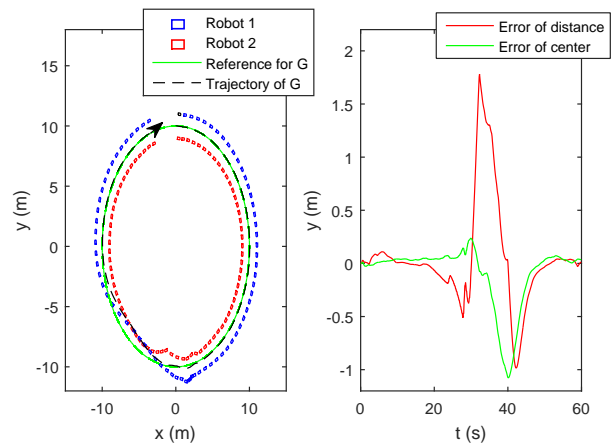

Fig. 5: Tracking performance without LQ performance

As depicted in Fig. 5, the set ($F_2^{MS}, U^{MS}, F_1^{MS}$) can ensure an acceptable tracking performance. However, the two robots are decoupled due to the diagonal feedback gain F_2^{MS} . Therefore, when the robot 1 affected by the disturbance, the robot 2 will not respond accordingly as shown in Fig. 5. This problem will be solved in the next part by further considering the LQ performance $\mathcal{R}2$.

Linear quadratic MS stabilization

In this part, Theorem 4 is adopted to solve the tracking problem for the cooperative robots platform and the LQ performance is considered. To this end, two different sets of parameters are defined for the cost functional (8) as:

1. Case 1: more weighting on center error as:

$$Q_1 = C^T \text{diag} [100, 100, 1, 1] C, R_1 = I.$$

2. Case 2: more weighting on distance error as:

$$Q_2 = C^T \text{diag} [1, 1, 100, 100] C, R_2 = I.$$

For the specific U matrix given as $U^{LQ1} = U^{LQ2} = U^{MS}$, the set $(F_2^{LQ1}, U^{LQ1}, K_1^{LQ1})$ associated to weighting matrices (Q_1, R_1) as well as the set $(F_2^{LQ2}, U^{LQ2}, K_1^{LQ2})$ associated to weighting matrices (Q_2, R_2) are obtained by solving Theorem 4:

$$F_2^{LQ1} = \begin{bmatrix} -2.7396 & 0.0344 & -1.6725 & 0.0975 \\ -2.0847 & 0.1264 & -0.6345 & 0.1643 \\ 0.2188 & -3.1688 & -0.1692 & -1.2658 \\ 0.1356 & -2.4344 & 0.0313 & -0.6619 \\ -1.6302 & 0.0840 & -2.8591 & -0.2314 \\ -0.6324 & 0.0440 & -2.1721 & -0.1826 \\ 0.3509 & -2.1336 & -0.4160 & -1.6617 \\ 0.1770 & -0.7053 & -0.1918 & -1.3351 \end{bmatrix}^T,$$

$$F_1^{LQ1} = \begin{bmatrix} -2.7036 & 36.0047 \\ 53.7705 & -3.5574 \\ 8.2581 & 35.1215 \\ 28.7722 & -0.7348 \end{bmatrix},$$

$$F_2^{LQ2} = \begin{bmatrix} -1.8522 & -0.1214 & 1.2829 & 0.5351 \\ -1.6998 & -0.1218 & 0.6285 & 0.2763 \\ -0.2653 & -1.5930 & 0.3348 & 0.0889 \\ -0.1290 & -1.5037 & 0.1945 & 0.0404 \\ 1.2526 & 0.1468 & -1.9160 & -0.5503 \\ 0.6270 & 0.1852 & -1.7560 & -0.2897 \\ 0.3319 & 0.8771 & -0.3924 & -0.5732 \\ 0.2661 & 0.0798 & -0.2818 & -1.0543 \end{bmatrix}^T,$$

$$F_1^{LQ2} = \begin{bmatrix} 1.2361 & 7.2705 \\ 9.4861 & -1.2535 \\ 0.7370 & 2.4018 \\ 4.0478 & -1.4697 \end{bmatrix}.$$

The Fig. 6 and Fig. 7 show the tracking performance and the evolution of the tracking error for the simulation with $(F_2^{LQ1}, U^{LQ1}, F_1^{LQ1})$ and $(F_2^{LQ2}, U^{LQ2}, F_1^{LQ2})$, respectively.

Compared with Fig. 5, we can see in Fig. 6 that the two robots cooperate to minimize the error between the center of robots and the reference trajectory. Therefore, when robot 1 moves outward, robot 2 moves inward correspondingly to reduce the center error. On the contrary, we can see in Fig. 7 that the two robots cooperate to minimize the distance error. Therefore, when robot 1 moves outward, robot 2 moves outward correspondingly. For both simulations, we can see that a better cooperation can be achieved by taking the LQ performance into consideration, and the impact of different weighting can be clearly seen.

Less conservative solution

In this part, Algorithm 2 is applied to reduce the conservatism of the results obtained by Theorem 4. The less conservative solutions U^{IT1} and U^{IT2} are computed by the Algorithm 2. By solving Theorem

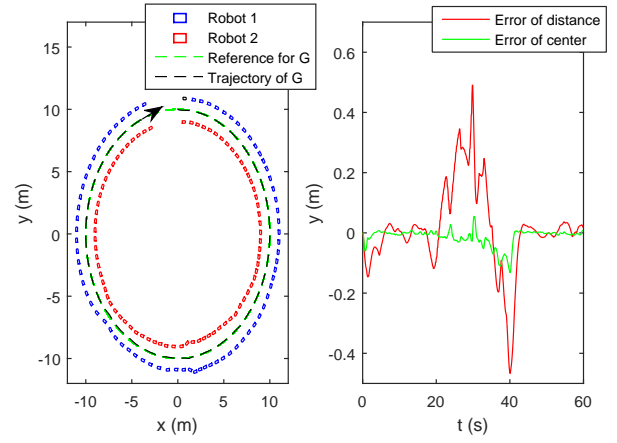

Fig. 6: Tracking performance with LQ performance to Case 1

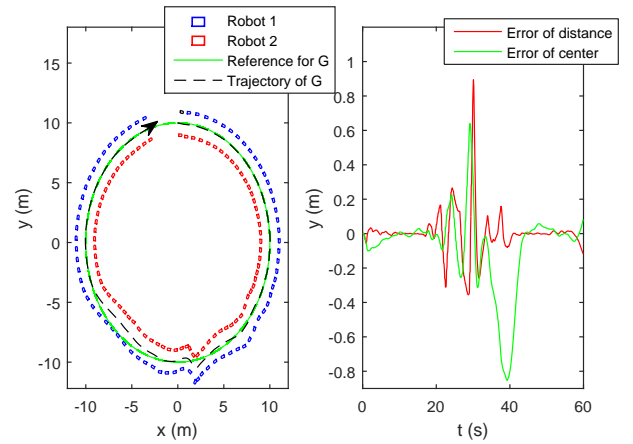

Fig. 7: Tracking performance with LQ performance to Case 2

4, $(F_2^{IT1}, U^{IT1}, F_1^{IT1})$ for Case1 and $(F_2^{IT2}, U^{IT2}, F_1^{IT2})$ for Case2 are obtained as:

$$F_2^{IT1} = \begin{bmatrix} -2.9862 & 0.0577 & -2.2707 & 0.3126 \\ -2.0796 & 0.0544 & -1.0517 & 0.2310 \\ 0.2290 & -3.2311 & -0.0816 & -2.1212 \\ 0.0630 & -2.3418 & -0.0654 & -0.8447 \\ -2.2135 & -0.0252 & -3.1356 & 0.0977 \\ -1.0488 & -0.0626 & -2.2072 & -0.0391 \\ 0.3696 & -2.0695 & -0.0726 & -3.3194 \\ 0.2338 & -0.8421 & -0.0476 & -2.3821 \end{bmatrix}^T,$$

$$U^{IT1} = \begin{bmatrix} -0.4756 & 0.3525 & -0.2949 & 0.7469 \\ -0.3994 & -0.5220 & -0.6550 & -0.2430 \\ -0.2469 & -0.6592 & 0.3571 & 0.2601 \\ -0.4012 & 0.3929 & -0.1263 & -0.5330 \\ -0.4326 & 0.1196 & 0.4352 & -0.0938 \\ -0.4530 & -0.0127 & 0.3887 & -0.1501 \end{bmatrix},$$

$$F_1^{IT1} = \begin{bmatrix} -2.6140 & 42.3516 \\ 54.0542 & -2.9927 \\ 4.6939 & 42.3949 \\ 52.8992 & -5.9123 \end{bmatrix},$$

$$F_2^{IT2} = \begin{bmatrix} -1.8739 & 0.0791 & 1.6055 & -0.0467 \\ -1.6072 & 0.0644 & 0.8574 & -0.0240 \\ 0.0890 & -2.0718 & -0.0244 & 1.4986 \\ 0.0649 & -1.8398 & 0.0015 & 0.7777 \\ 1.4554 & -0.0433 & -2.1979 & 0.0333 \\ 0.8499 & 0.0006 & -1.9238 & -0.0018 \\ -0.0667 & 1.4724 & 0.0247 & -2.1361 \\ -0.0250 & 0.7764 & -0.0022 & -1.9095 \end{bmatrix}^T,$$

$$U^{IT2} = \begin{bmatrix} -0.3321 & 0.4088 & 0.7094 & -0.4485 \\ -0.3162 & -0.4452 & 0.5267 & 0.6500 \\ -0.3013 & 0.6568 & -0.1845 & 0.4510 \\ -0.4313 & -0.4338 & -0.1275 & -0.4144 \\ -0.5817 & 0.0651 & -0.2971 & -0.0319 \\ -0.4178 & -0.1044 & -0.2841 & 0.0116 \end{bmatrix},$$

$$F_1^{IT2} = \begin{bmatrix} 0.6232 & 5.9630 \\ 9.3562 & -1.4436 \\ 0.8339 & 1.6239 \\ 2.6789 & -0.5191 \end{bmatrix}.$$

The average tracking errors of one hundred sets of stochastic simulation with different choice of (F_1, U, F_2) are given in Table 1. It can be seen in Table 1 that compared with the given matrix U^{LQ1} , the iterative solution U^{IT1} by solving Algorithm 2 greatly reduces the center error by 63.9% and also reduces the distance error by 13.6%. And compared with the given matrix U^{LQ2} , the iterative solution U^{IT2} reduces the center error and distance error by 17.2% and 22%, respectively. Therefore, it is clear that Algorithm 2 can reduce the conservatism of the results by iterative computation of coding matrix U . It is observed from Table 1 that the controller synthesis and coding design (equivalently channel design) are of equal importance for such network-based systems, which indeed reveals that the fusion of control theory (cybernetics) [44] and information theory [45] takes a crucial role in the analysis and synthesis of NCSs.

Table 1 Tracking errors

Strategy	$x_0^T P x_0$	Average error of center (m)	Average error of distance (m)
MS stabilization	-	1.9934	3.9880
Case 1 (with U^{LQ1})	65488	0.8344	2.0884
Case 1 (with U^{IT1})	42341	0.3014	1.8041
Case 2 (with U^{LQ2})	59172	1.4403	0.5545
Case 2 (with U^{IT2})	35277	1.1918	0.4323

For comparisons, The MS stabilization results in [30] is extended to the tracking problem by the design method proposed in this paper. In other words, a MS stabilizing feedback gain F_2 is obtained by the design method appealed in [30] and the corresponding feedforward gain F_1 is computed by Theorem 3. Fig. 8 shows the tracking performance and the evolution of the tracking error. As depicted in Fig. 8, the two robots are decoupled and the tracking performance is not as satisfied as the iterative solutions given by Theorem 4 in this paper.

5 Conclusion

In this paper, stochastic LQ control problem under asymptotic tracking for linear discrete-time systems with lossy channels. In order to solve this problem, the co-design approach of controller, encoder and decoder is adopted. A theorem that reveals the fundamental limitation among the H_2 norm of the plant, data arrival rates and coding matrices is first derived such that the closed-loop system is

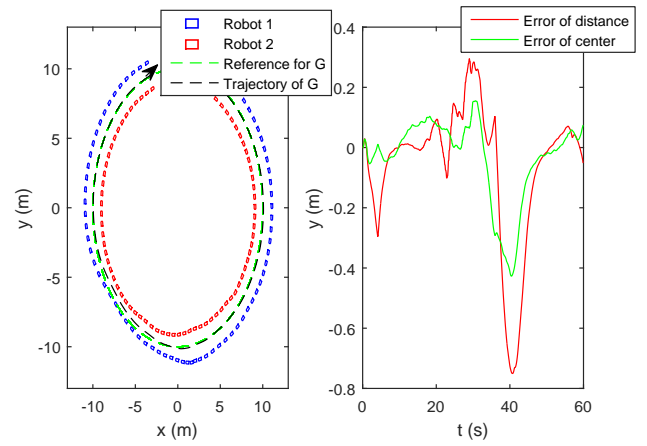

Fig. 8: Tracking performance of extended results in [30]

MS stable. To further consider the LQ performance objective, a new condition is proposed that gives a way for the controller synthesis for minimizing the stochastic LQ criterion under the MS stability constraint. Finally, a Sylvester equation is appealed for the asymptotic tracking issue and the resulting feedforward gain is structured. To verify the effectiveness of the proposed method, an example of two cooperative robots is included. It is worth noting that the time delay is of great importance in analysis and design of NCSs and one of our future research topics is to include network-induced delay in the present framework.

6 References

- 1 J. Baillieul and P. J. Antsaklis. Control and communication challenges in networked real-time systems. *Proceedings of the IEEE*, 95(1):9–28, 2007.
- 2 L. X. Zhang, H. J. Gao, and O. Kaynak. Network-induced constraints in networked control systems - A survey. *IEEE Transactions on Industrial Informatics*, 9(1):403–416, 2013.
- 3 L. D. Xu, W. He, and S. C. Li. Internet of things in industries: a survey. *IEEE Transactions on Industrial Informatics*, 10(4):2233–2243, 2014.
- 4 Y. C. Cao, W. W. Yu, W. Ren, and G. R. Chen. An overview of recent progress in the study of distributed multi-agent coordination. *IEEE Transactions on Industrial Informatics*, 9(1):427–438, 2013.
- 5 X. Chen, F. Hao, and B. L. Ma. Periodic event-triggered cooperative control of multiple non-holonomic wheeled mobile robots. *IET Control Theory and Applications*, 11(6):890–899, 2017.
- 6 D. Zhang, G. Li, K. Zheng, X. Ming, and Z. H. Pan. An energy-balanced routing method based on forward-aware factor for wireless sensor networks. *IEEE Transactions on Industrial Informatics*, 10(1):766–773, 2014.
- 7 D. R. Ding, Z. D. Wang, B. Shen, and H. L. Dong. Event-triggered distributed h-infinity state estimation with packet dropouts through sensor networks. *IET Control Theory and Applications*, 9(13):1948–1955, 2015.
- 8 W. Zhu and Z. P. Jiang. Event-based leader-following consensus of multi-agent systems with input time delay. *IEEE Transactions on Automatic Control*, 60(5):1362–1367, 2015.
- 9 S. B. Li, G. Feng, J. Wang, X. Y. Luo, and X. P. Guan. Adaptive control for cooperative linear output regulation of heterogeneous multi-agent systems with periodic switching topology. *IET Control Theory and Applications*, 9(1):34–41, 2015.
- 10 B. Sinopoli, L. Schenato, M. Franceschetti, K. Poolla, M. Jordan, and S. Sastry. Kalman filtering with intermittent observations. *IEEE Transactions on Automatic Control*, 49(9):1453–1464, 2004.
- 11 Z. W. Wang, X. D. Wang, and L. H. Liu. Stochastic optimal linear control of wireless networked control systems with delays and packet losses. *IET Control Theory and Applications*, 10(7):742–751, 2016.
- 12 H. J. Gao, T. W. Chen, and J. Lam. A new delay system approach to network-based control. *Automatica*, 44(1):39–52, 2008.
- 13 X. Q. Lu, N. K. Chen, Y. N. Wang, L. Qu, and J. G. Lai. Distributed impulsive control for islanded microgrids with variable communication delays. *IET Control Theory and Applications*, 10(14):1732–1739, 2016.
- 14 N. Elia. Remote stabilization over fading channels. *Systems and Control Letters*, 54(3):237–249, 2005.
- 15 A. I. Maass and E. I. Silva. Performance limits in the control of single-input linear time-invariant plants over fading channels. *IET Control Theory and Applications*, 8(14):1384–1395, 2014.
- 16 G. Nair and R. Evans. Stabilizability of stochastic linear systems with finite feedback data rate. *SIAM Journal on Control and Optimization*, 43(2):413–436, 2004.
- 17 A. Bartoszewicz and P. Lesniewski. Reaching law-based sliding mode congestion control for communication networks. *IET Control Theory and Applications*,

- 8(17):1914–1920, 2014.
- 18 M. Y. Fu and L. H. Xie. The sector bound approach to quantized feedback control. *IEEE Transactions on Automatic Control*, 50(11):1698–1711, 2005.
 - 19 E. Tian, D. Yue, and X. Zhao. Quantised control design for networked control systems. *IET Control Theory and Applications*, 1(6):1693–1699, 2007.
 - 20 N. Elia and S. K. Mitter. Stabilization of linear systems with limited information. *IEEE Transactions on Automatic Control*, 46(9):1384–1400, 2001.
 - 21 V. Gupta and N. C. Martins. On stability in the presence of analog erasure channel between the controller and the actuator. *IEEE Transactions on Automatic Control*, 55(1):175–179, 2010.
 - 22 K. Tsumura, H. Ishii, and H. Hoshina. Tradeoffs between quantization and packet loss in networked control of linear systems. *Automatica*, 45(12):2963–2970, 2009.
 - 23 Y. Feng, X. Chen, and G. X. Gu. Observer-based stabilizing controllers for discrete-time systems with quantized signal and multiplicative random noise. *SIAM Journal on Control and Optimization*, 54(1):251–265, 2016.
 - 24 Y. Feng, X. Chen, and G. X. Gu. Output feedback stabilization for discrete-time systems under limited communication. *IEEE Transactions on Automatic Control*, 62(4):1927–1932, 2017.
 - 25 Y. F. Su and J. Huang. Cooperative output regulation with application to multi-agent consensus under switching network. *IEEE Transactions on Systems, Man, and Cybernetics*, 42(3):864–875, 2012.
 - 26 Y. Feng and M. Yagoubi. Comprehensive admissibility for descriptor systems. *Automatica*, 66(C):271–275, 2016.
 - 27 G. X. Gu and L. Qiu. Stabilization of networked multi-input systems with channel resource allocation. *IFAC World Congress*, 41(2):625–630, 2008.
 - 28 L. Qiu, G. X. Gu, and W. Chen. Stabilization of networked multi-input systems with channel resource allocation. *IEEE Transactions on Automatic Control*, 58(3):59–63, 2013.
 - 29 N. Xiao, L. H. Xie, and L. Qiu. Feedback stabilization of discrete-time networked systems over fading channels. *IEEE Transactions on Automatic Control*, 57(9):2176–2189, 2012.
 - 30 W. Chen, S. B. Wang, and L. Qiu. MIMO control using MIMO communication: A majorization condition for networked stabilizability. *American Control Conference*, pages 2205–2210, July 2015.
 - 31 B. D. O. Anderson and J. B. Moore. *Linear optimal control*. Prentice-Hall, Englewood Cliffs, 1971.
 - 32 Q. Q. Liu and F. Jin. LQG control of networked control systems with limited information. *Mathematical Problems in Engineering*, 206391:1–12, 2014.
 - 33 H. X. Wang and H. S. Zhang. LQ control for Itô-type stochastic systems with input delays. *Automatica*, 49(12):3538–3549, 2013.
 - 34 Q. Zhang and G. Yin. On nearly optimal controls of hybrid LQG problems. *IEEE Transactions on Automatic Control*, 44(12):2271–2282, 1999.
 - 35 L. Schenato. To zero or to hold control inputs with lossy links?. *IEEE Transactions on Automatic Control*, 54(5):1093–1099, 2009.
 - 36 V. Gupta, B. Hassibi, and R. M. Murray. Optimal LQG control across packet-dropping links. *Systems and Control Letters*, 56(6):439–446, 2007.
 - 37 A. A. Stoorvogel, A. Saberi, and P. Sannuti. Performance with regulation constraints. *Automatica*, 36(10):1443–1456, 2000.
 - 38 A. A. Stoorvogel, A. Saberi, and P. Sannuti. *Control of linear systems with regulation and input constraints*. Springer, London, 2000.
 - 39 J. Huang. *Nonlinear output regulation: theory and applications*. SIAM, Philadelphia, 2004.
 - 40 S. M. Rump. Optimal scaling for p-norms and componentwise distance to singularity. *IMA Journal of Numerical Analysis*, 23(1):1–9, 2003.
 - 41 C. Scherer, P. Gahinet, and M. Chilali. Multiobjective output-feedback control via LMI optimization. *IEEE Transactions on Automatic Control*, 42(7):896–911, 1997.
 - 42 J. M. Zhou, G. X. Gu, and X. Chen. Distributed Kalman filtering over wireless sensor networks in the presence of data packet drops. *IEEE Transactions on Automatic Control*, DOI:10.1109/TAC.2018.2854644, accepted.
 - 43 G. Conte, C.H. Moog, and A.M. Perdon. *Algebraic methods for nonlinear control system*. Springer, London, 2007.
 - 44 Norbert Wiener. *Cybernetics: or control and communication in the animal and the machine*. Hermann & Cie, Paris, 1948.
 - 45 Claude E Shannon. A mathematical theory of communication. *Bell System Technical Journal*, 27(3):379–423, 1948.