

Blade pitch optimization for an offshore vertical axis wind turbine model

Hubert Branger, Sukanta Roy, Christopher Luneau,
Denis Bourras and Benoit Paillard



branger@irphe.univ-mrs.fr

Support:



Outline

- Introduction
- IRPHE/Pyhtéas wind-wave facility
- Wind turbine physical model
- Tests and Results on pitching optimization
- Conclusions - Perspectives

Introduction:

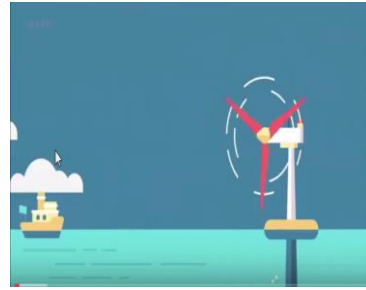

All the large offshore wind turbines in the world are Horizontal Axis Wind Turbines

There is no Large **Offshore Vertical Axis Wind Turbine (VAWT)**



- No real background on the large ones
- Not able to self-start → need a motor to start
- Not able to self-stop → need a brake system to stop
- Vibrations, torque oscillations
- **No Financial support**

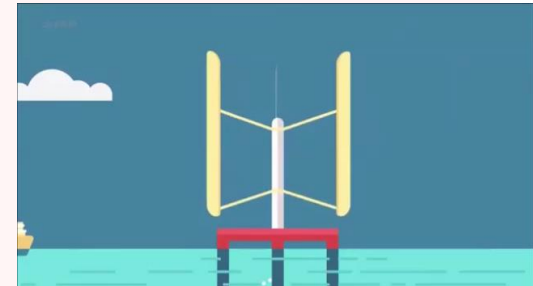

But there might be some good points :

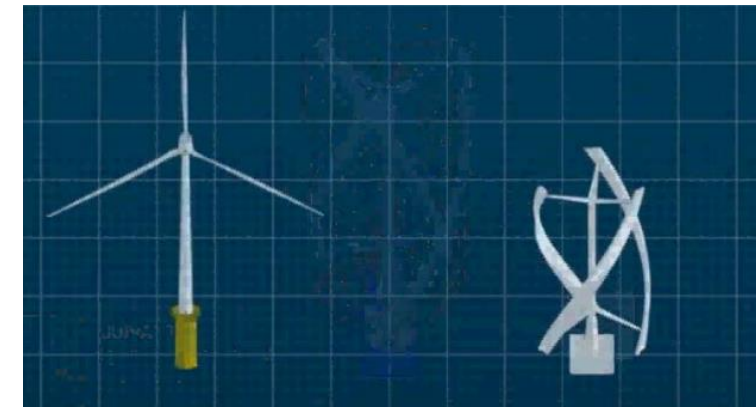

1) No need to have a Yaw system if the wind direction change

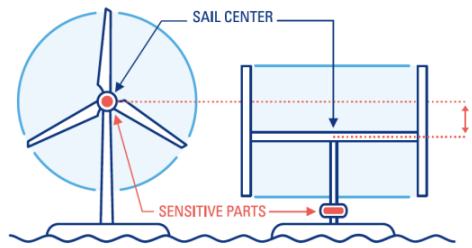

2) → gravity center is lower → floater 20% smaller
Guo et al. (2018), Huijs et al (2018)

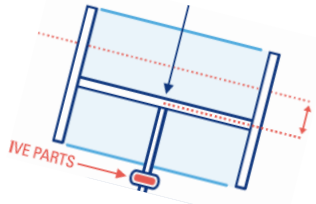

3) → the turbine still works even at large inclination
good for floating platforms
Chowdhury et al (2016)

4) → Wind Farms: more turbines/km² → more Power/km²
Cp is better if turbines work 2x2 or 3x3
Arab et al (2017), Douak et al (2018)

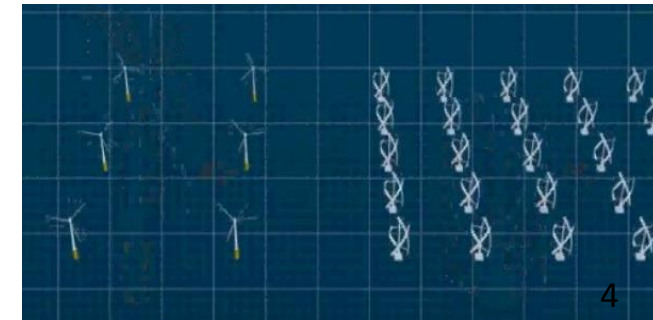

Three years ago: **Eolfi had the SpinFloat project:**

→ to design 6 MW Vertical Axis Wind Turbine with **pitching blades**

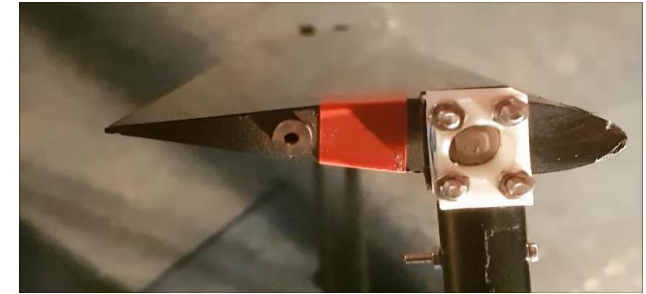

Irphe had French support

in order to :

- build a small experimental model
- make experiments in IRPHE facility
- find good pitching laws



Why pitching the blades ?

1) → For a better driving force

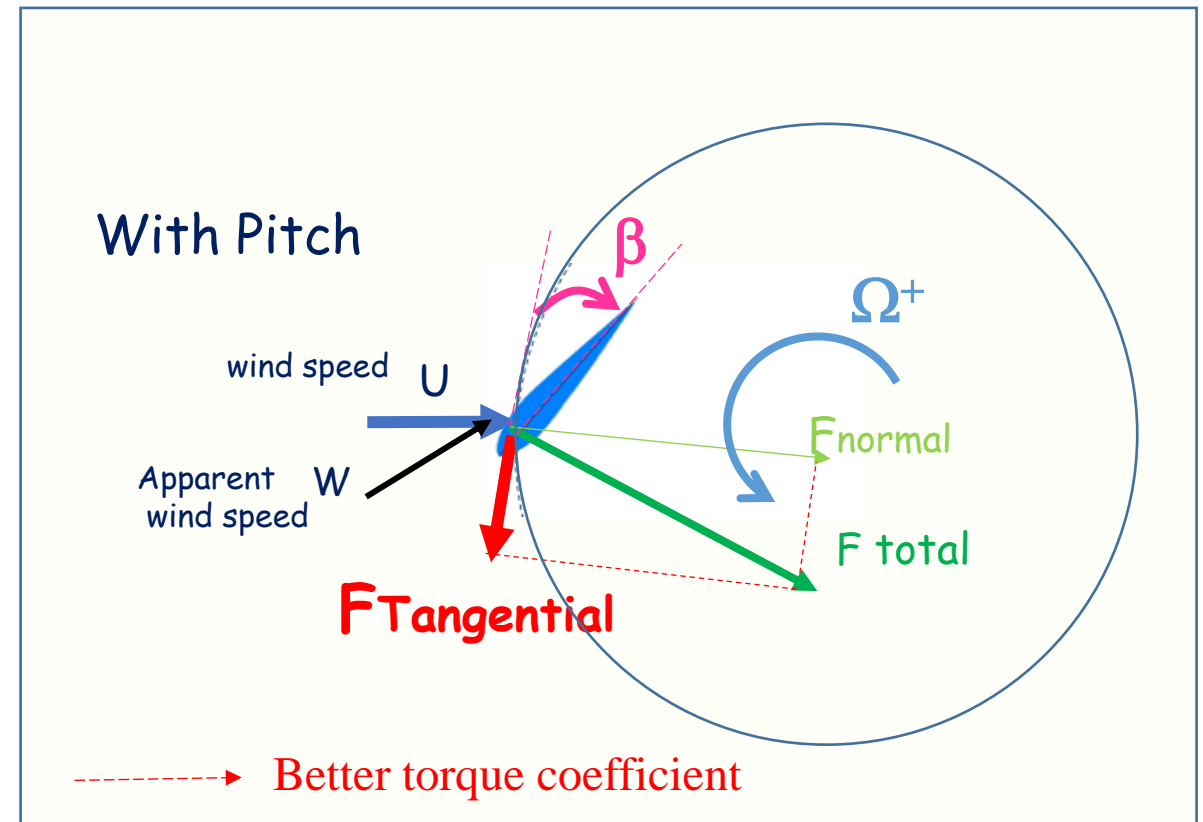
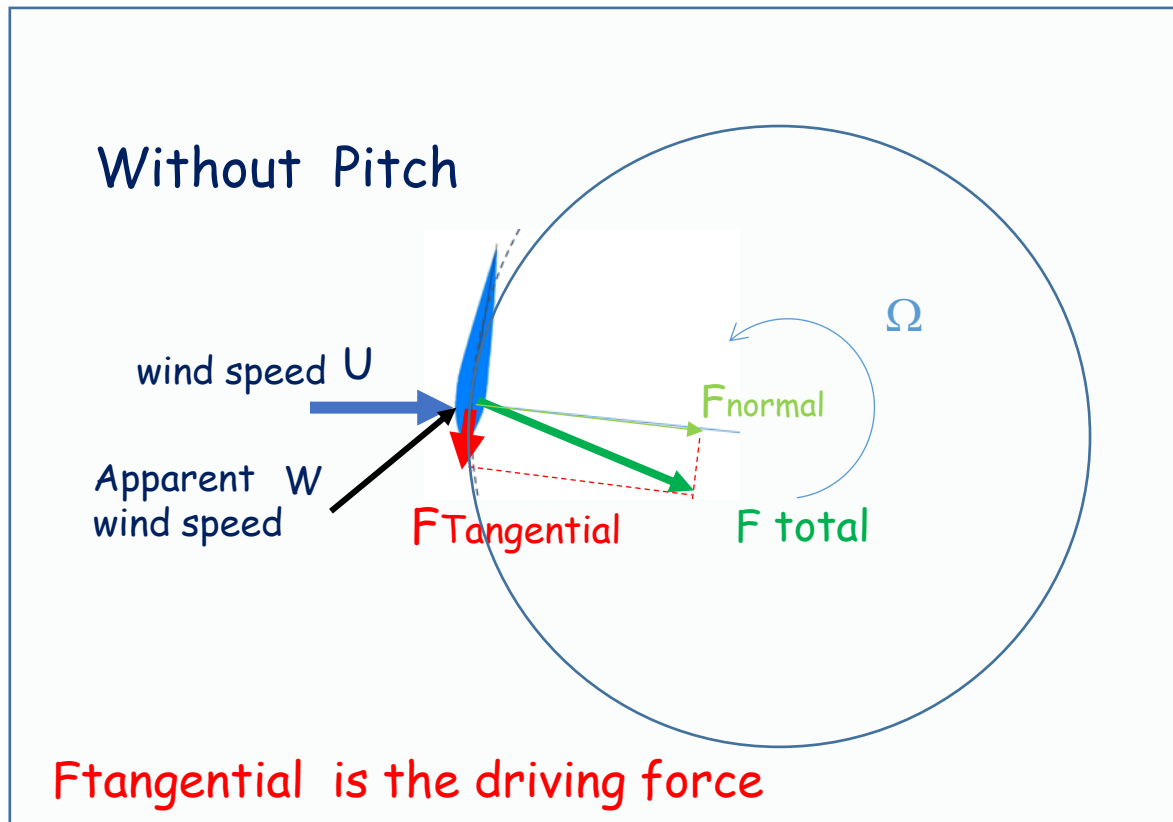

Why pitching the blades ?

2) Good for self starting :

Incoming
Wind speed
 U



No pitch \rightarrow No movement
 \rightarrow equilibrium position

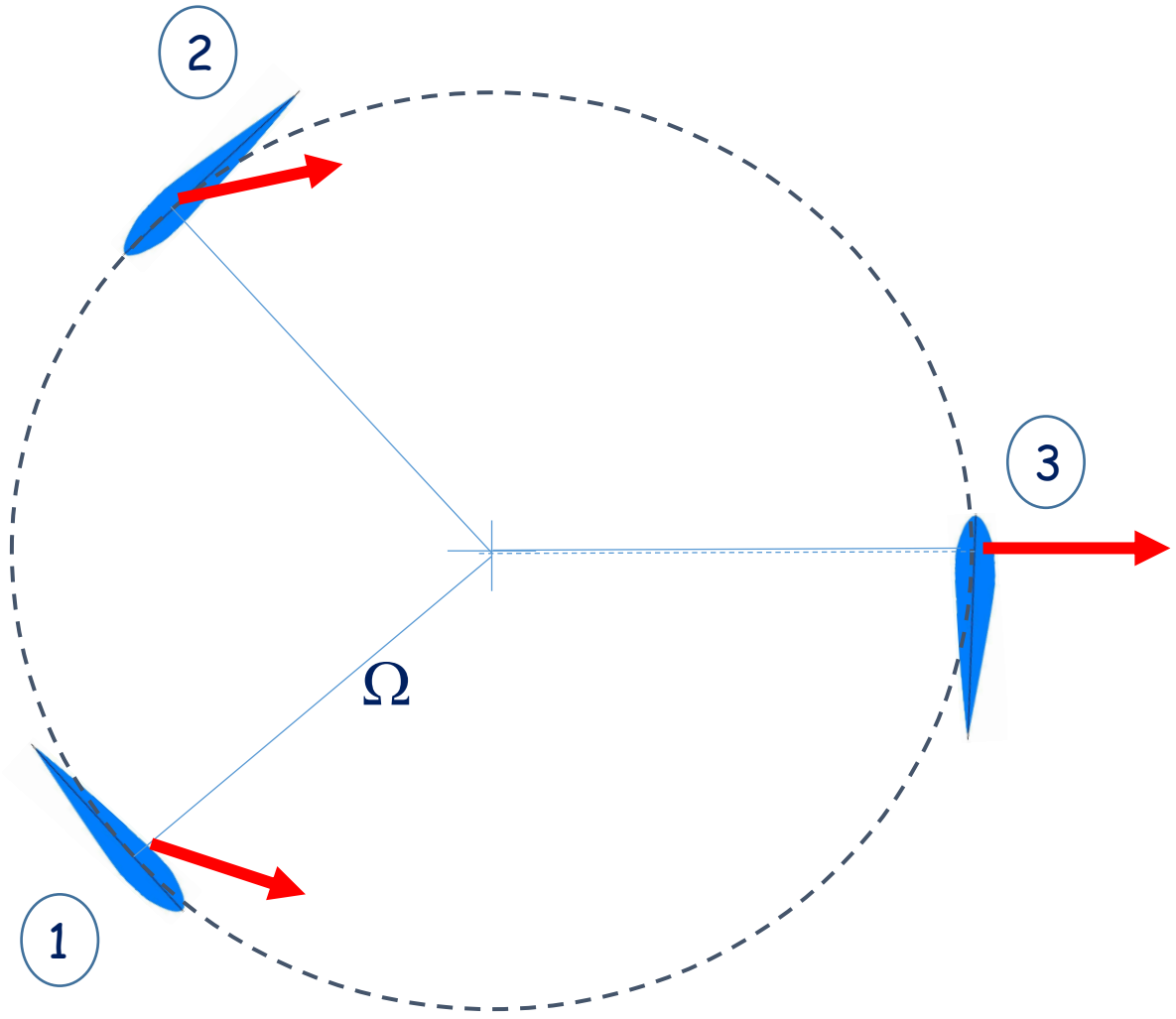

Why pitching the blades ?

2) Good for self starting :

Incoming
Wind speed
 U



With pitch \rightarrow rotation starts

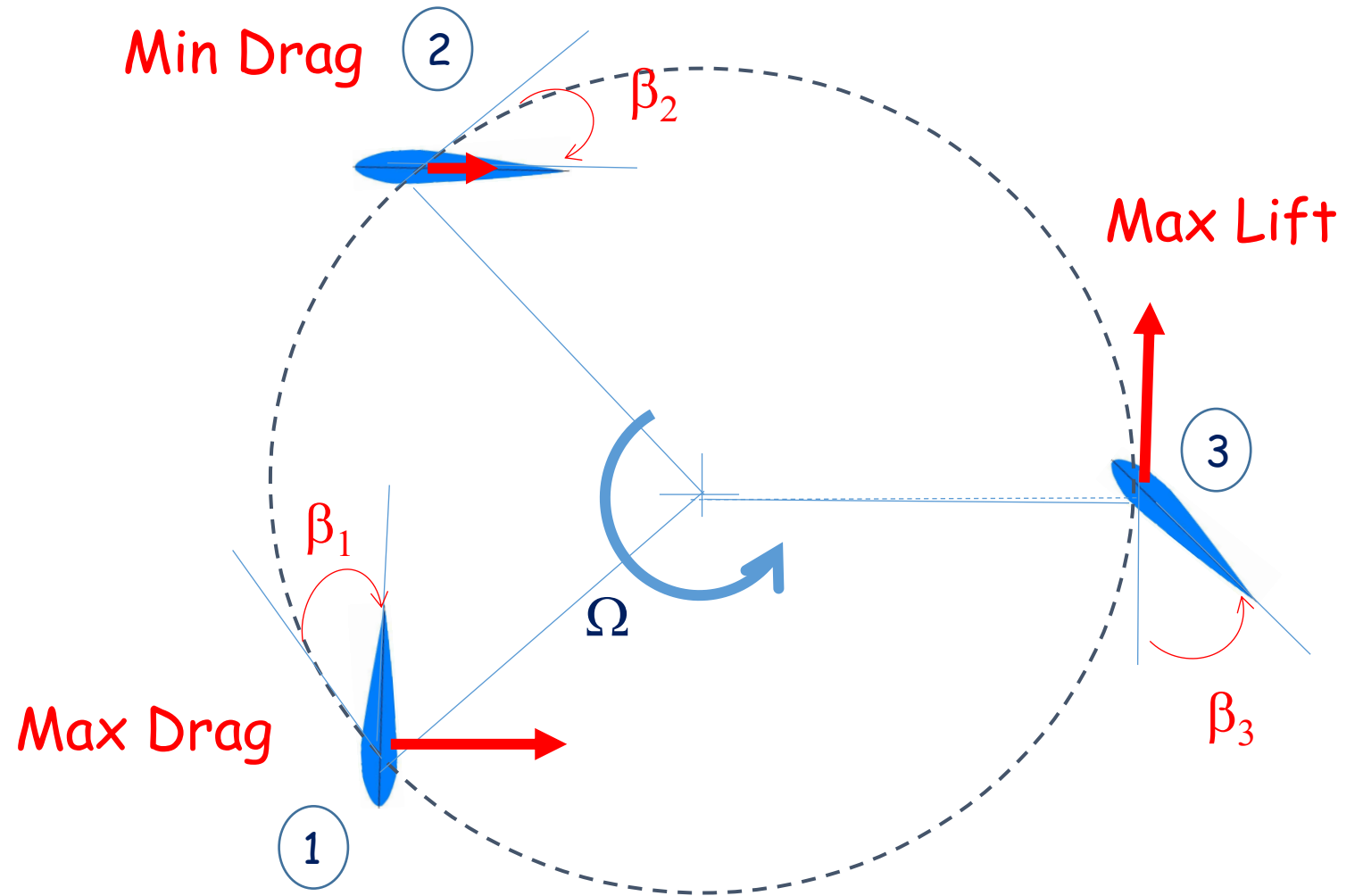

Why pitching the blades ?

3) To slow down or stop:

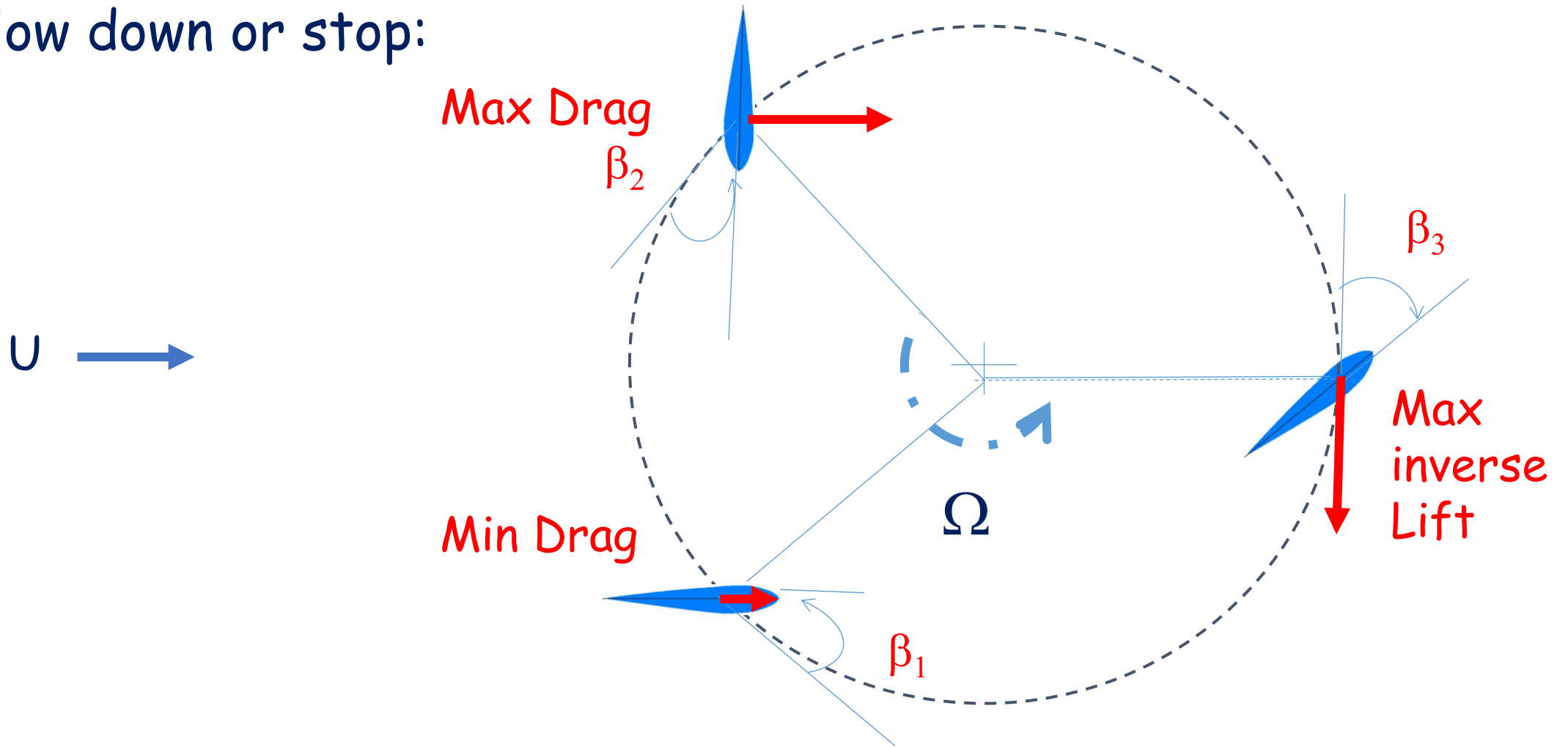

Pitching the blades for Vertical Axis Wind Turbines is not new:

There have been many published papers on Vertical wind turbine pitching

Very Recent papers:

- Douak et al (2018) → pitching efficient for self starting
- Chen et al (2018) : → pitching is efficient with a simple sinus function $\beta = \beta_{\max} \sin(\theta)$
- Zhao et al (2018) : → efficient pitching $\beta(\theta, TSR) = \beta_{\max} \sin(\theta) - \beta_2 (TSR) \sin^2(\theta)$
- Bayati et al 2018, Battisti et al 2018, Li et al 2018 → pitching is efficient: → 20% on Power Coefficient
- Xu et al 2019: → more complex pitching law: $\beta = \sum_{j=1}^3 (\sum_{k=1}^3 a_{jk} TSR^{k-1} \sin(j\theta))$

BUT , they mainly concern:

- relatively small turbines,
- or blades with large chords,
- or turbine with high solidity ratio,
- or rod crank or cycloid systems

(center of rotation of the blades \neq center rotation of turbine)

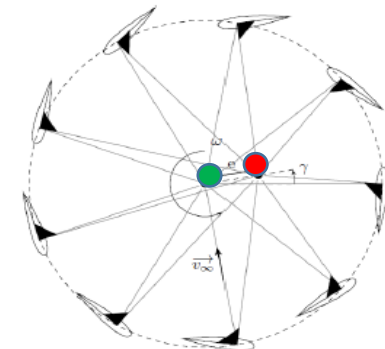

Only a few papers are related to large vertical axis wind turbines

IRPHE/Pythéas Large air sea interaction facility in Marseille

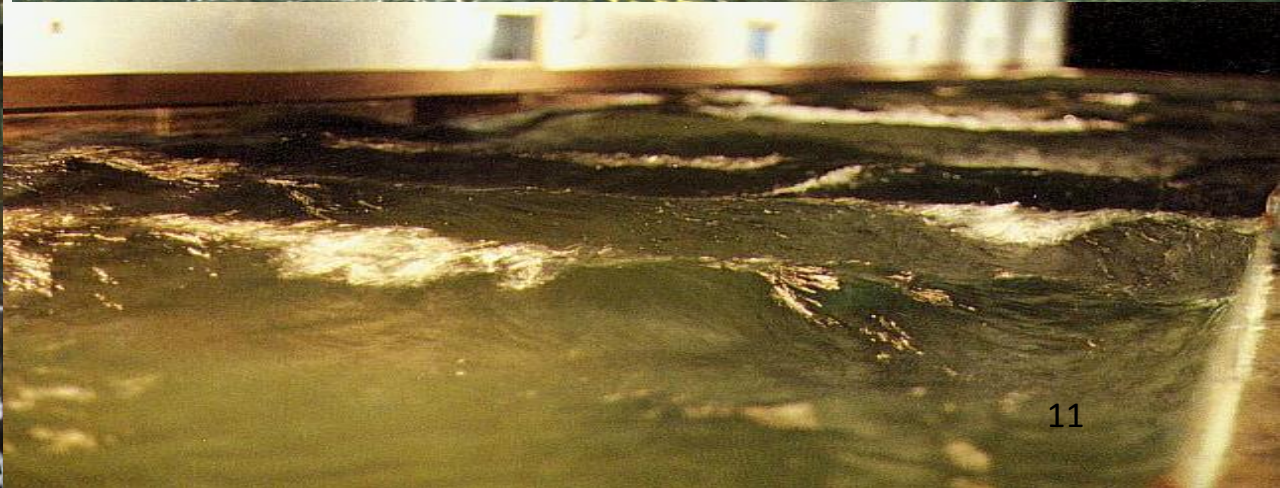
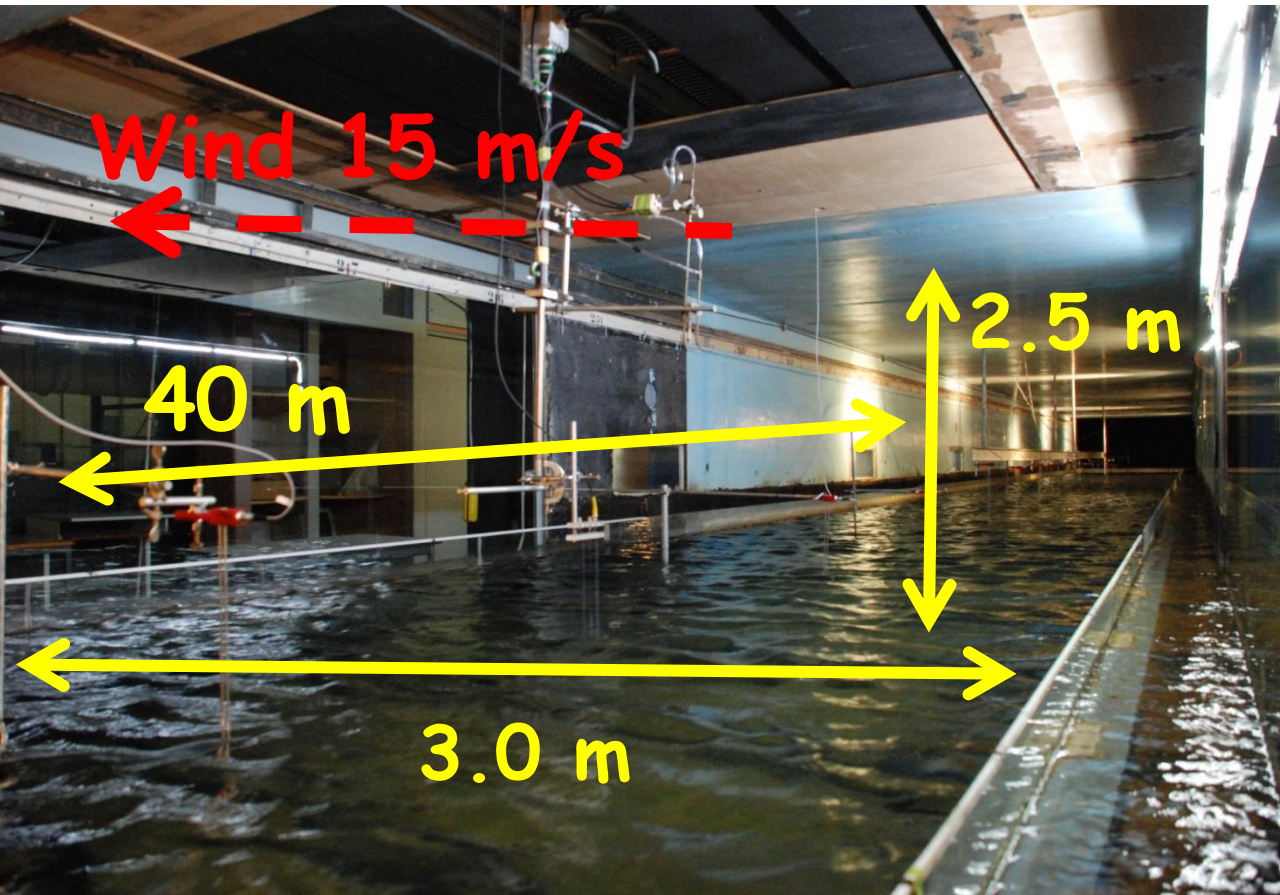
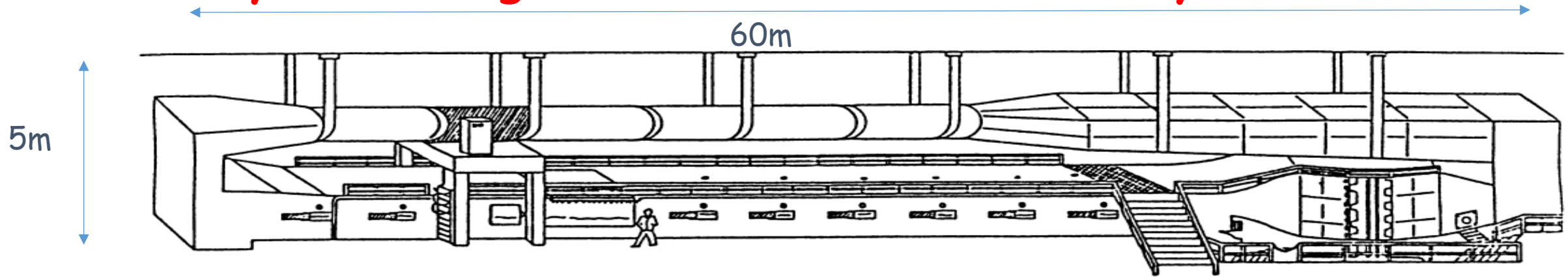

We previously made research works on floating wind turbines in this facility



Semi-sub Tension Leg Platform (TLP)



Oscillating column



Tri-floater Vertical axis
Branger et al, WESC, Cork, June 17-19, 2019



Tri-floater, Horizontal axis

To design the wind turbine physical model in relation with the **EOLFI** requirements for the **WINDFLOAT** project, we made preliminary studies using open source software **XFOIL** and **QBLADE** (Double Multi Stream Tube model + Lift Line Theory + some 3D effects)

Studies on aspect ratio : $a_R = (\text{blade length} / \text{diameter})$

+

Studies on solidity ratio: $s_R = (\text{number of blades} * \text{Chord} / \text{Diameter})$

+

Studies on different blade profiles

Finally for the physical model, we end to :

- 3 Selig 1046 blades,
- Height: 90 cm ,
- Chord: 9 cm,
- Radius: 80 cm

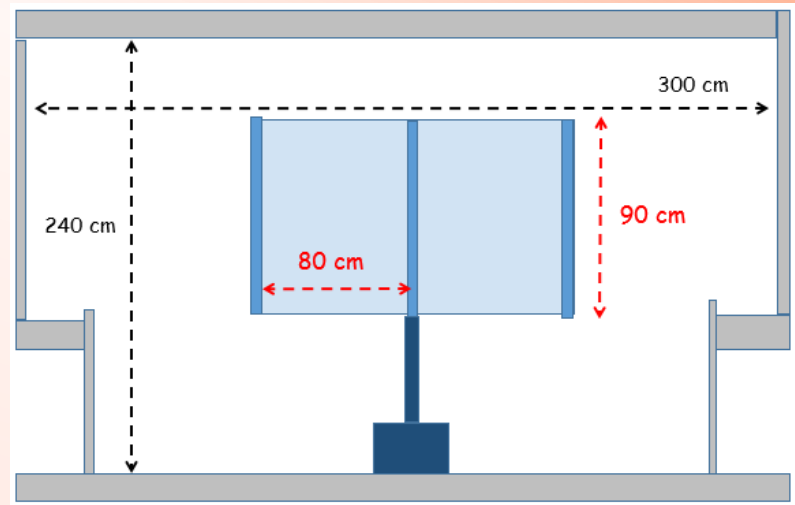
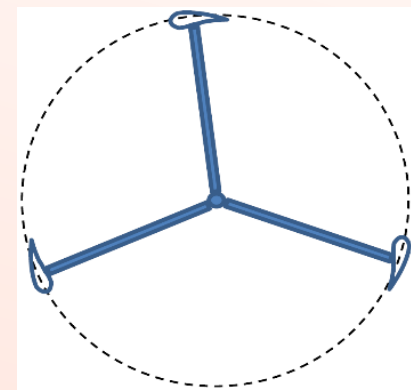

Cross section of the facility

Solidity Ratio=0.17

Blocage factor=0.18

There is nothing on literature about Selig 1046 blades.

→ We measured Lift and Drag Coefficients for all possible incidence angles (-180° to $+180^\circ$)

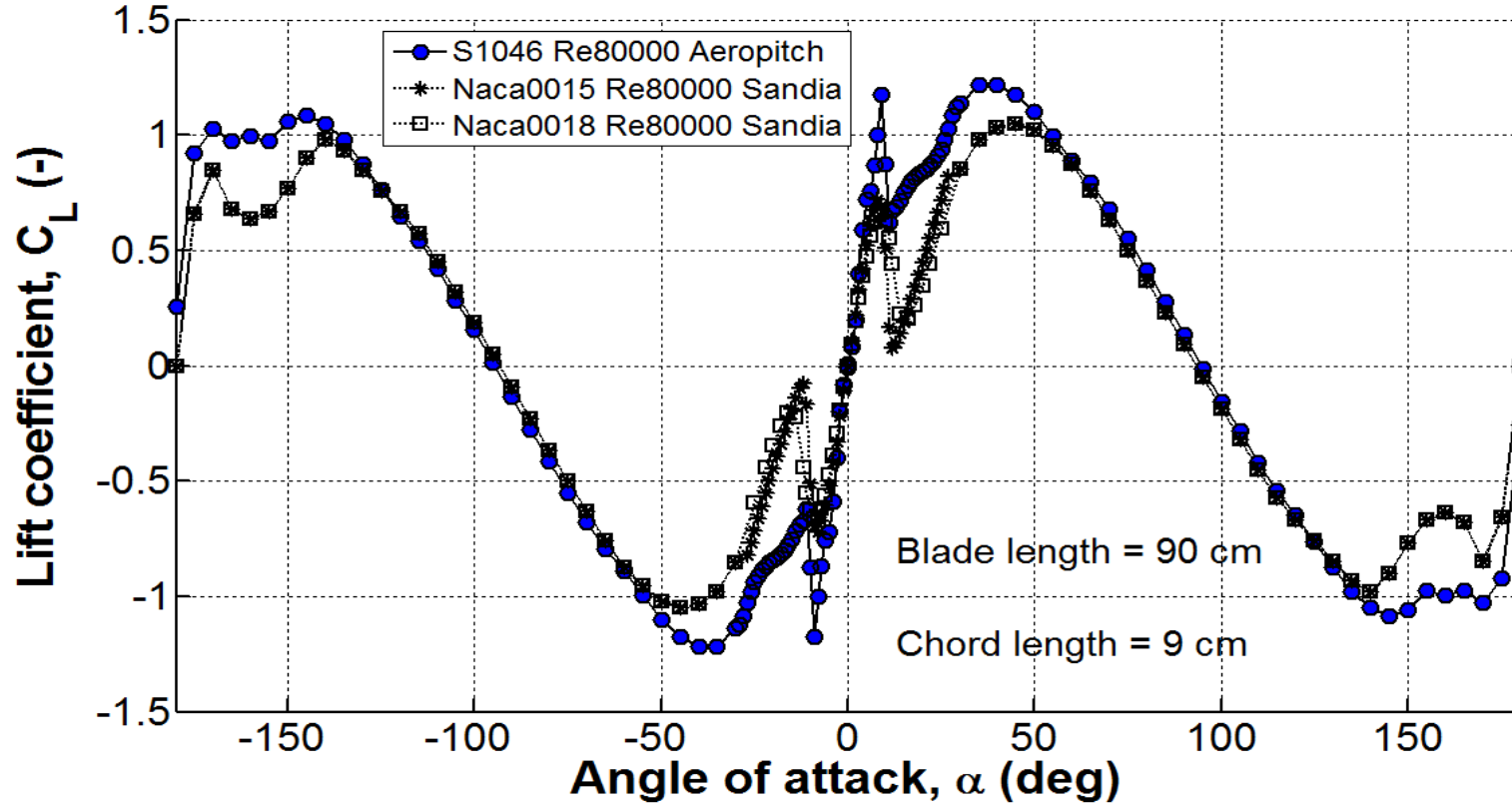

Lift coefficient : comparisons with Naca profiles

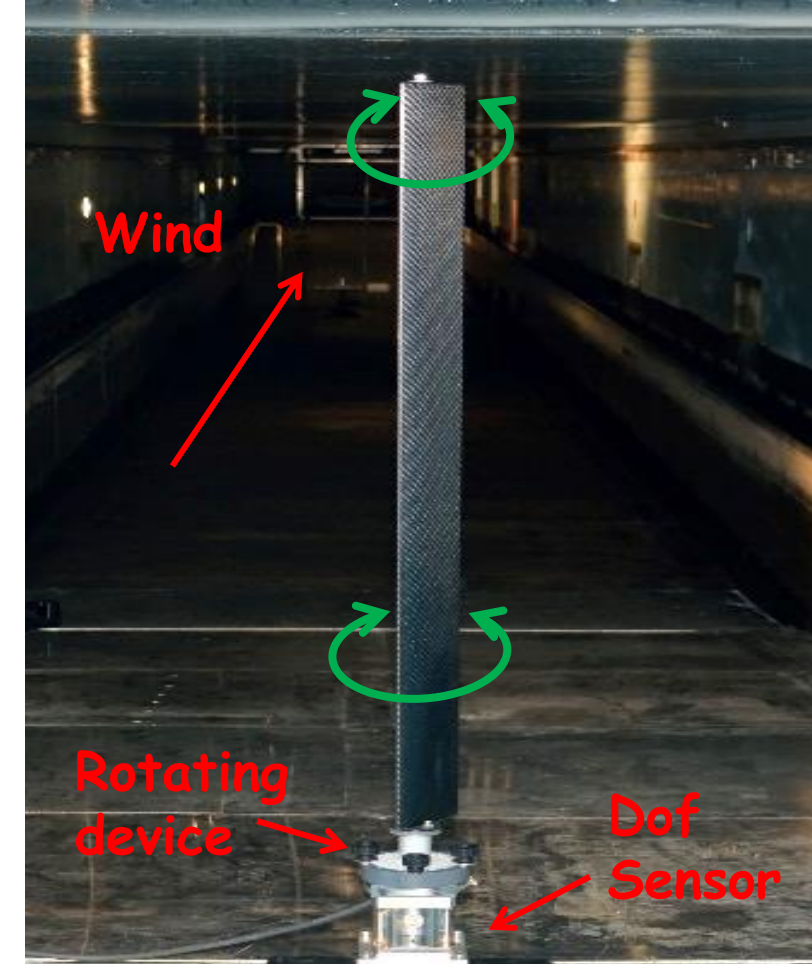

Selig 1046 blade

We built almost everything
(connections, bases, caps, electronics, ...)

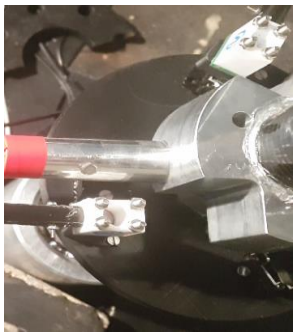
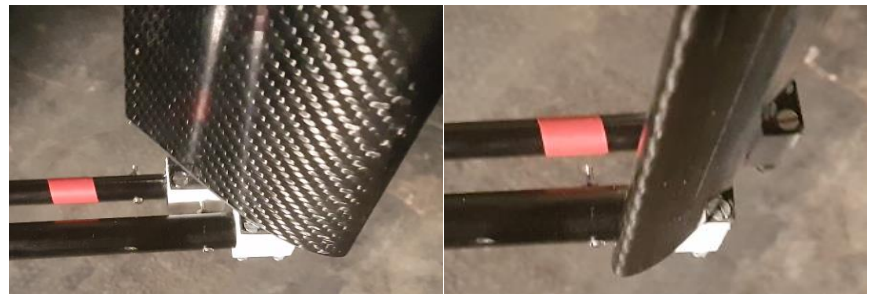
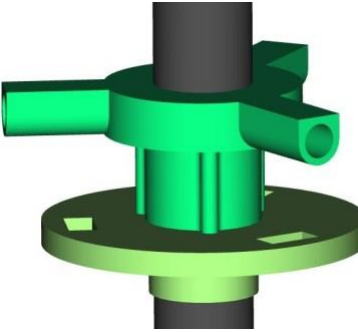

Cap Design

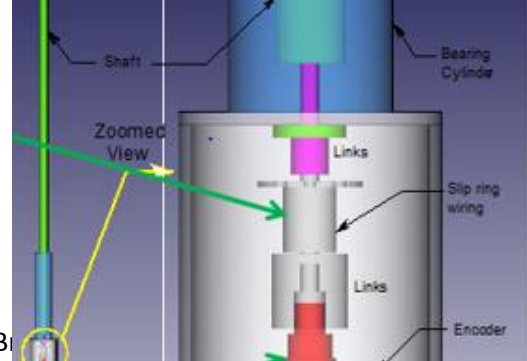
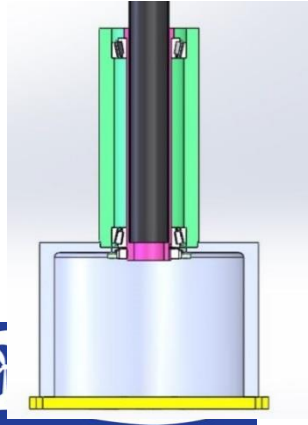
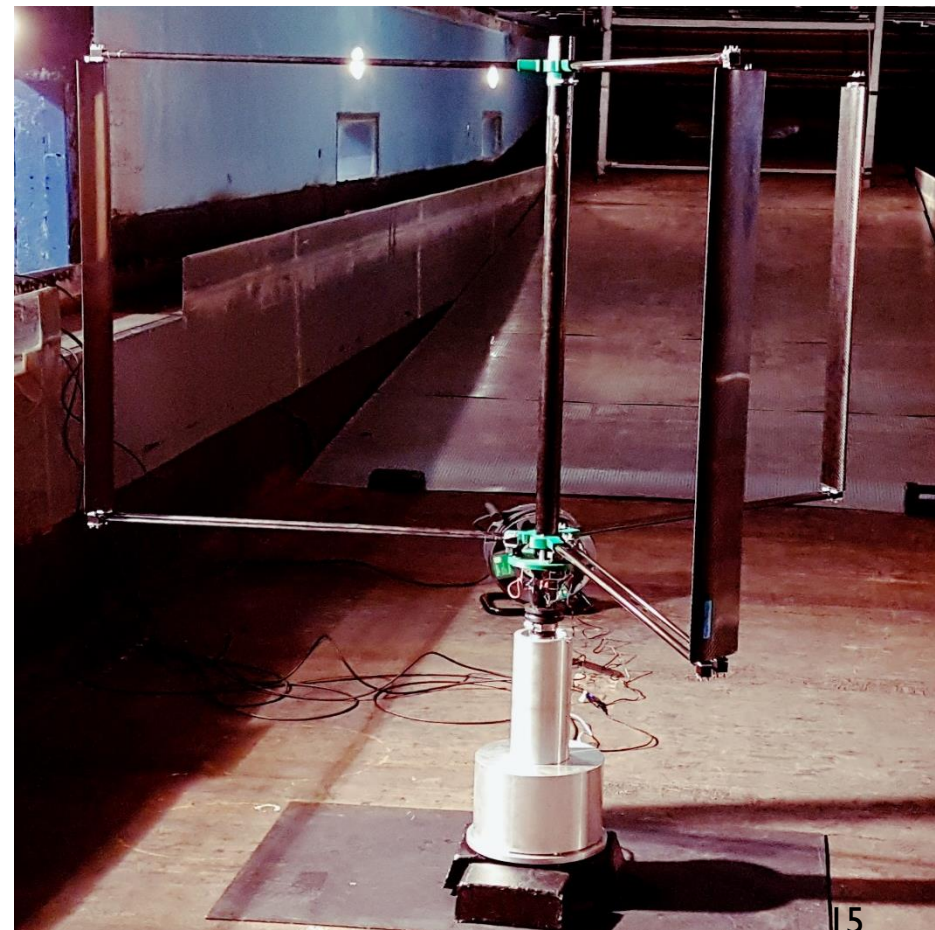
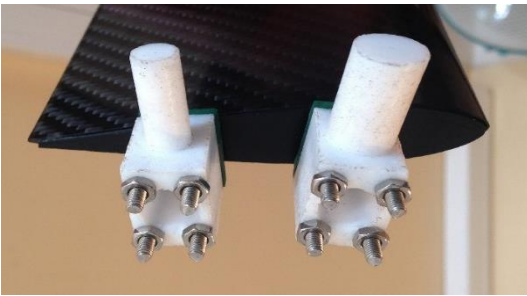
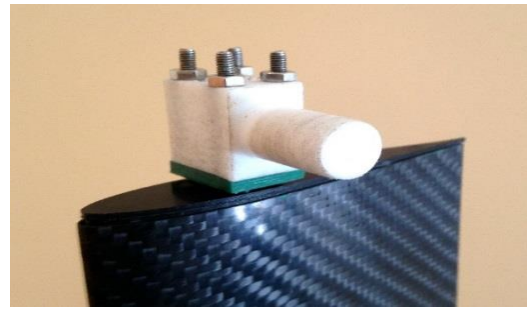
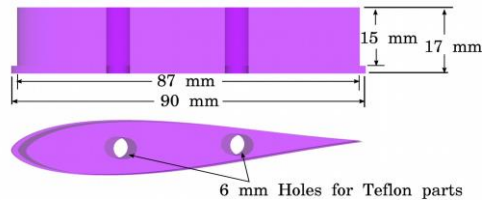

To pitch the blades, we used 3 servomotors

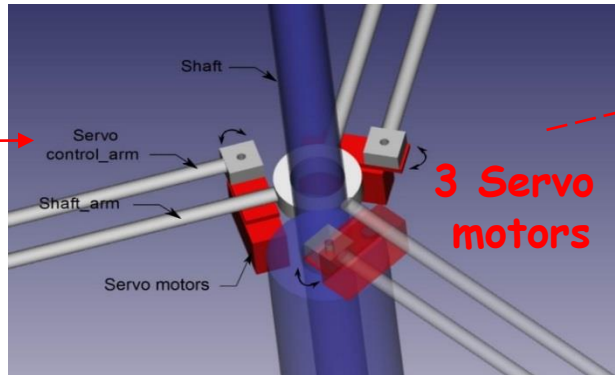
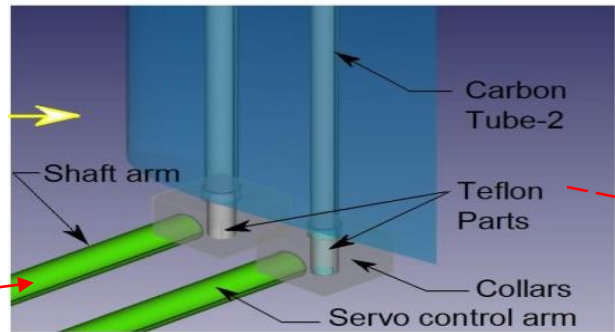
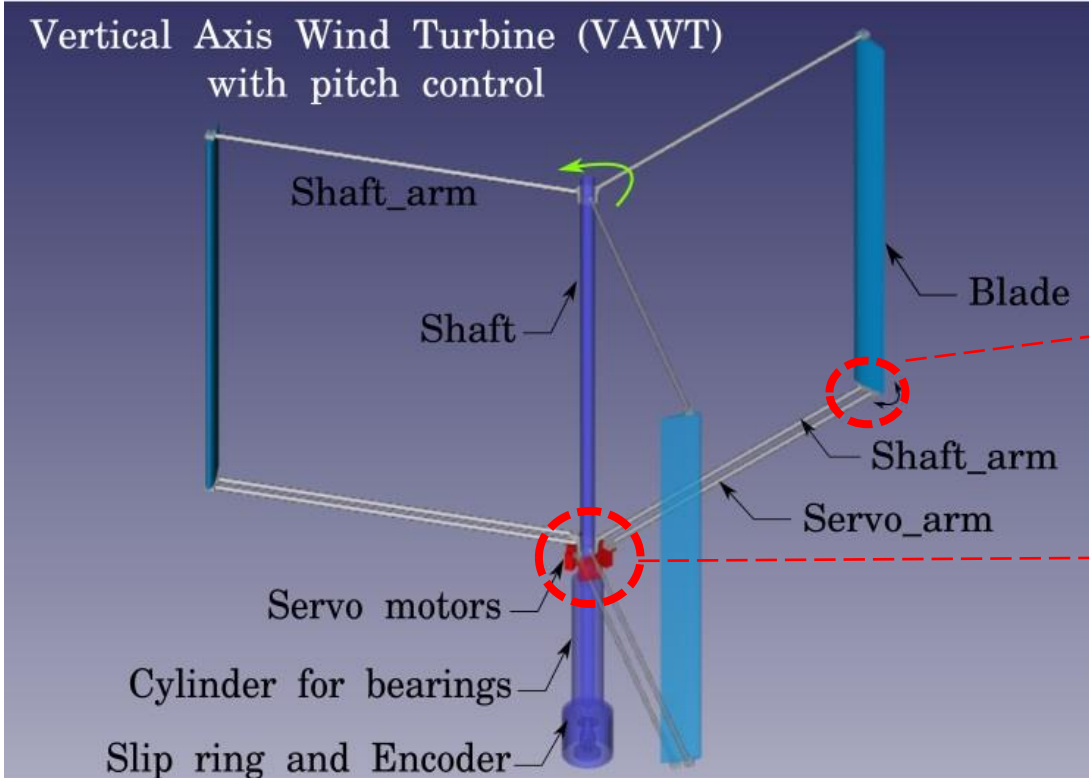

Servo motors very efficient: Able to pitch 60° in 1/10 s

How it works: Control-command loop for the pitch

Computer with Python program



We have a pitch command:

$$\begin{aligned} \text{pitch}_{blade1} &= f(U, TSR, \theta) \\ \text{pitch}_{blade2} &= f(U, TSR, \theta + \pi/3) \\ \text{pitch}_{blade3} &= f(U, TSR, \theta + 2\pi/3) \end{aligned}$$

U : wind speed

TSR : Tip Speed Ratio= $R \Omega / U$

θ : blade azimuthal position

Wind speed U



Pitch updating

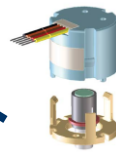

Rotational encoder
to measure
 Ω , TSR and θ

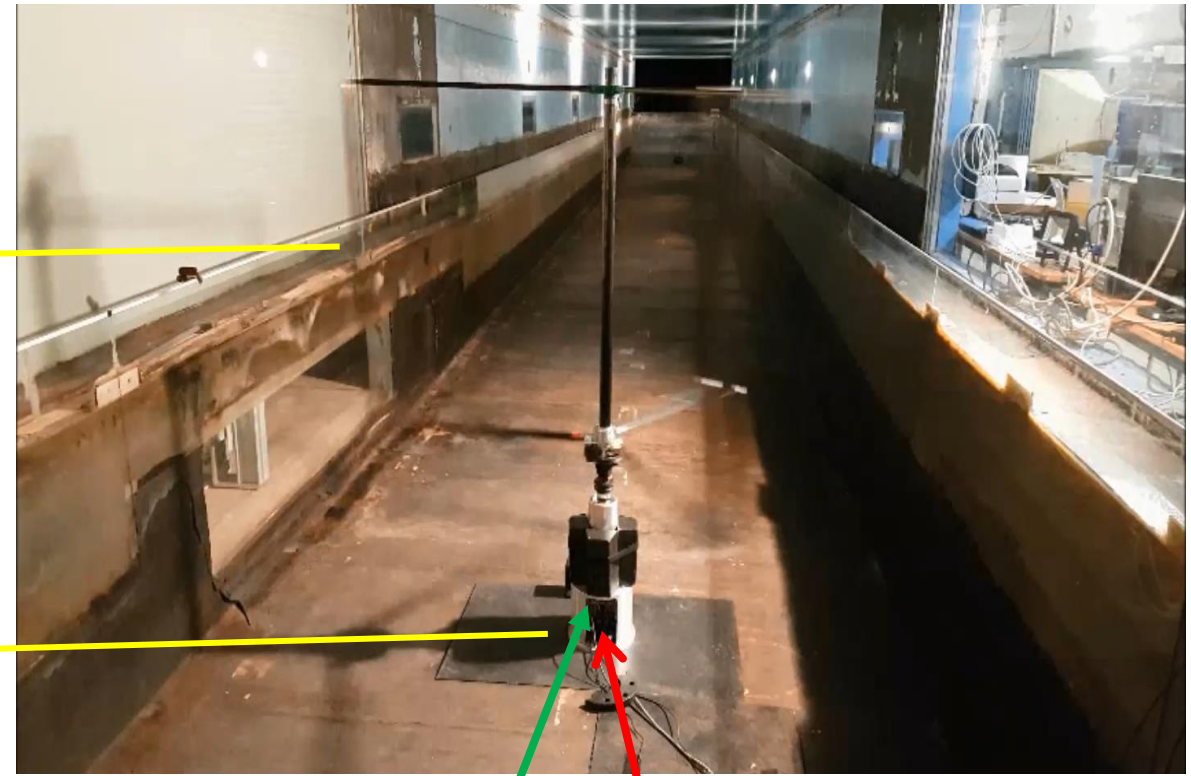

Teensy card
with an ARDUINO
Software coding



Control

Another Teensy Card
controls the servomotor
movements

Command

Results:

With a very simple **sinus command**

$$\begin{cases} pitch1 = a0 + a1 \sin(\theta1) \\ pitch2 = a0 + a1 \sin(\theta1 + \pi/3) \\ pitch3 = a0 + a1 \sin(\theta1 + 2\pi/3) \end{cases}$$

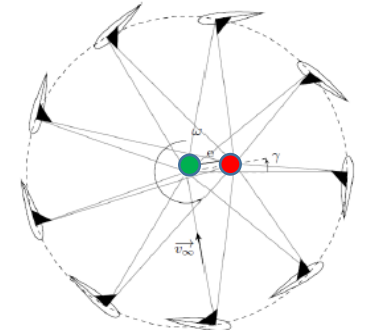

(equivalent to a mechanical rod-crank or cycloid systems)

Wind turbine rotational velocity increased by a factor 4 !

Ω : Rotational speed

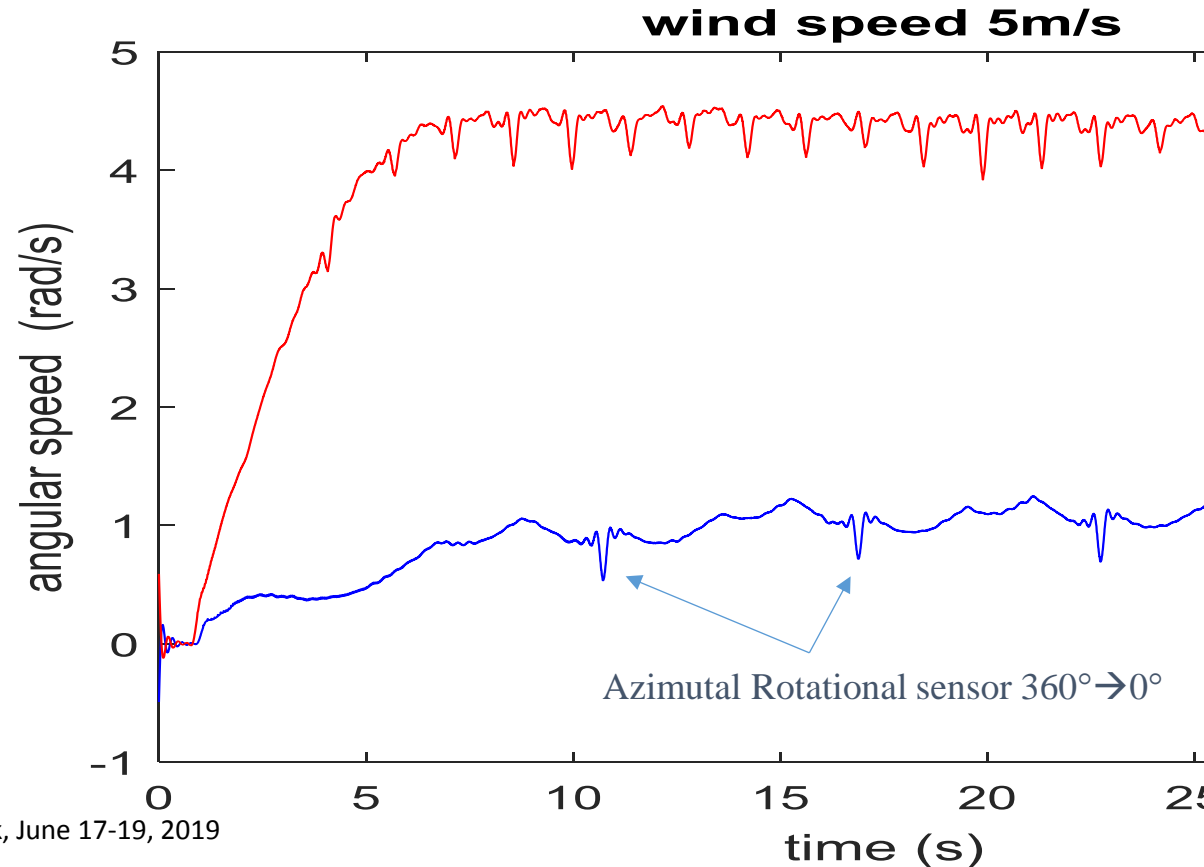

With pitch

Without pitch

Results: Self-starting :

U= 4m/s , no pitch:
turbine does not start

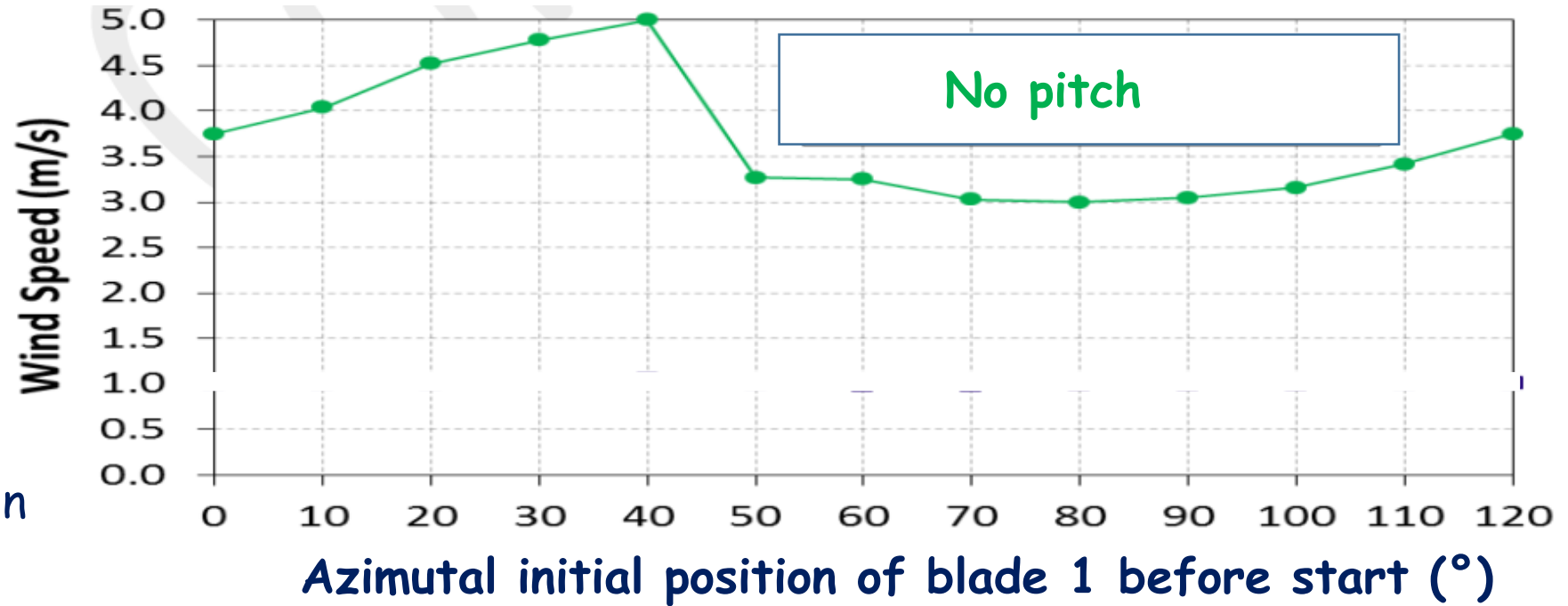

Minimum
wind speed
to start rotation

Results: Self-starting :

U= 4m/s , no pitch:
turbine does not start

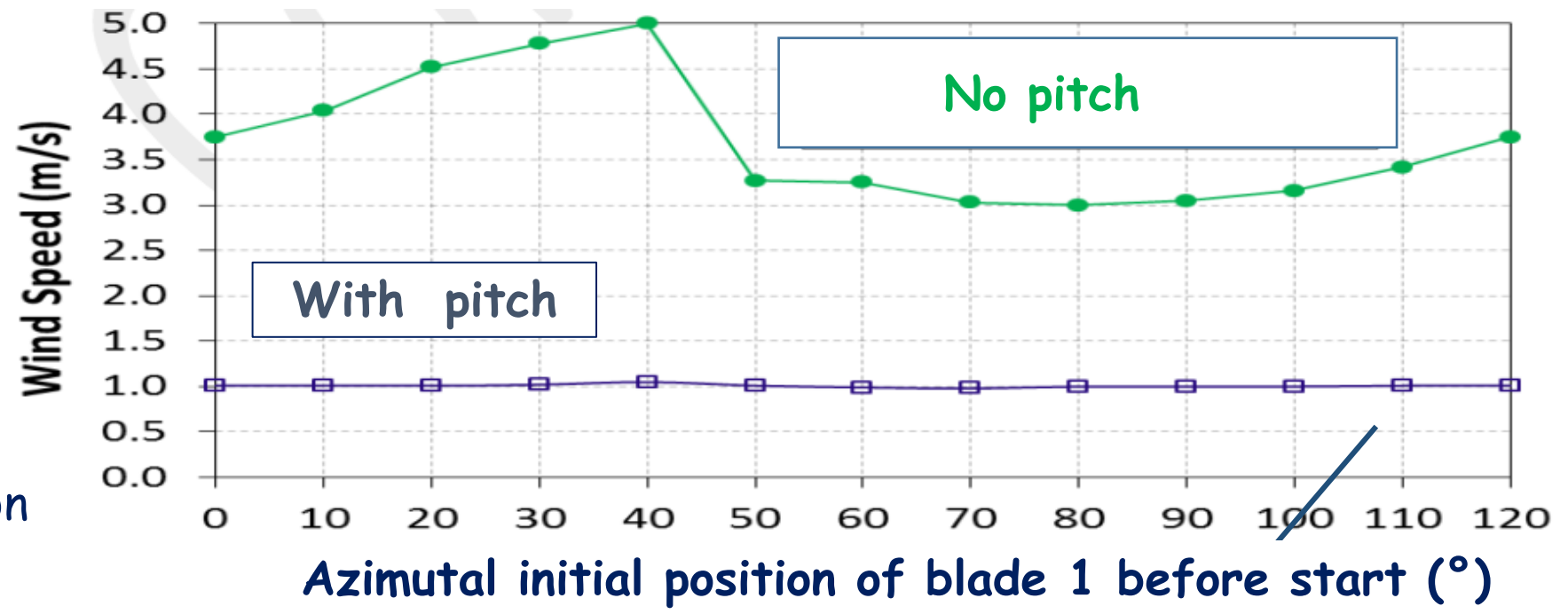

Minimum wind speed to start rotation

U= 1m/s : pitch on turbine starts



Results: Self-stop :

If you change β in $-\beta$, the turbine slows down and stops.

β to stop = $-\beta$ to start

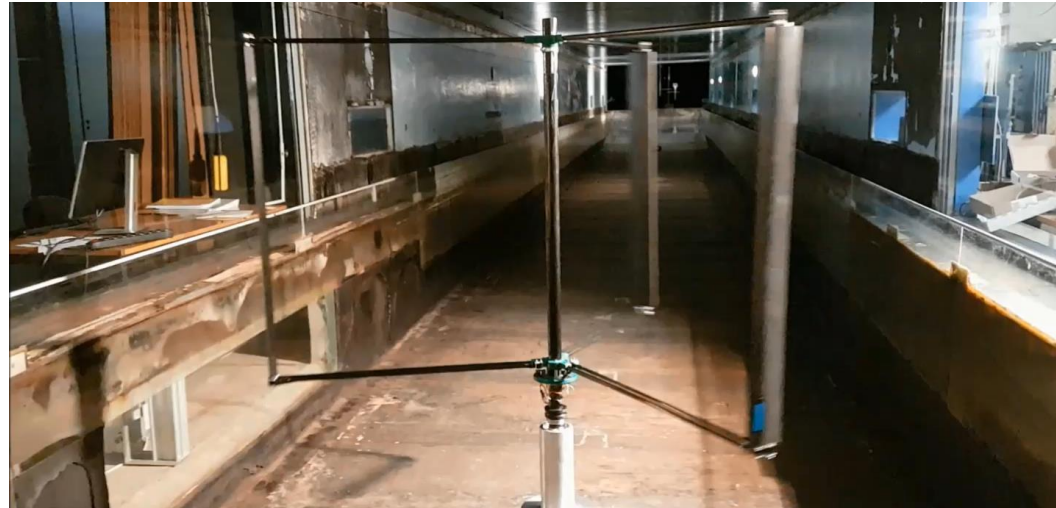

How to find better pitch laws ?

$\theta = \text{Blade Azimut}$

- 1) Pitch laws: not only $\sin(\theta)$ but also the harmonics: $\sin(2\theta)$, ...
- 2) Pitch laws: not only $\sin(\theta)$ but also phase shift $\sin(\theta + \varphi)$
- 3) Pitch laws: not only $\sin(\theta)$ but also the quadrature $\cos(\theta)$
- 4) Pitch laws: coefficients should depend on TSR

→ 12 parameters to find

How to find « optimal » coefficients a_1, a_2, \dots, a_{12} ? → Genetic algorithm « Dakota »

(Open source Optimization toolbox)

Dakota routines are based on Bayesian statistics, hybrid optimization

Goal: **TSR maximum**

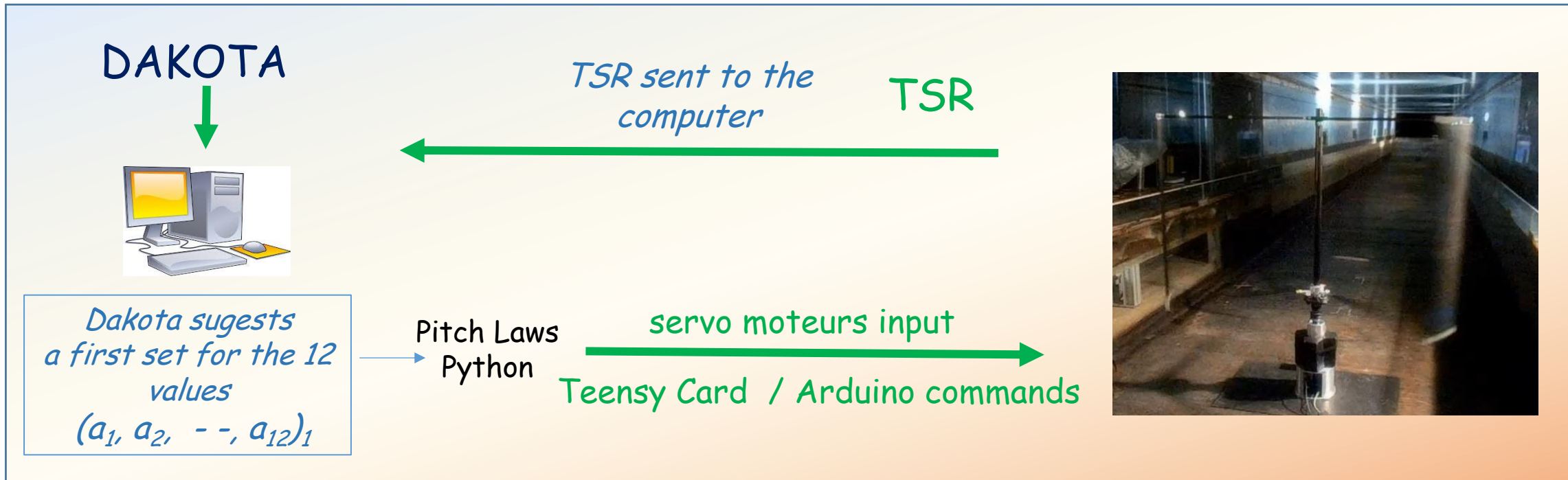

How to find « optimal » coefficients a_1, a_2, \dots, a_{12} ? → Genetic algorithm « Dakota »

(Open source Optimization toolbox)

Dakota routines are based on Bayesian statistics, hybrid optimization

Goal: TSR maximum

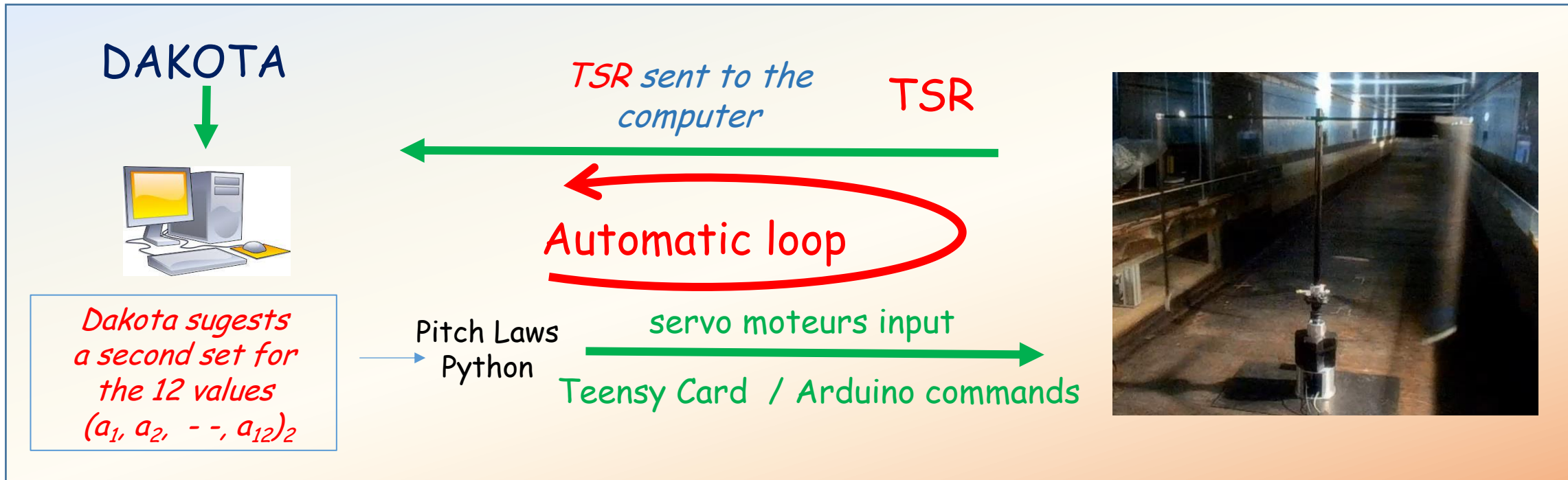

How to find « optimal » coefficients a_1, a_2, \dots, a_{12} ? → Genetic algorithm « Dakota »

(Open source Optimization toolbox)

Dakota routines are based on Bayesian statistics, hybrid optimization

Goal: **TSR maximum**

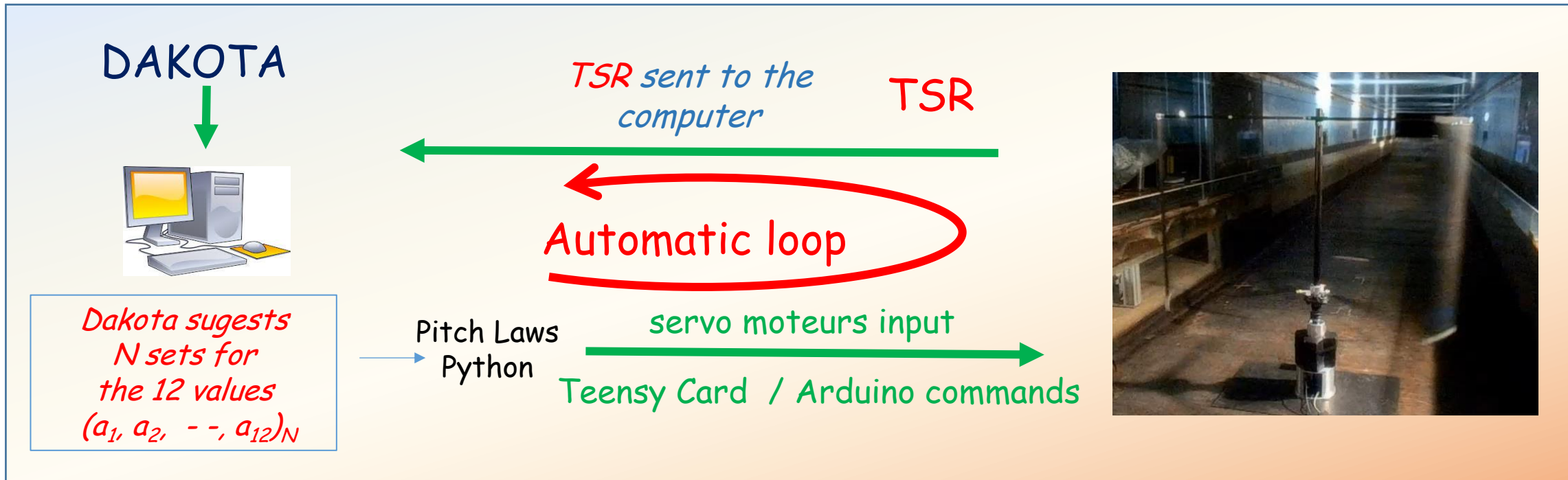

The procedure is automatic (no hand control)

1 run = 2 min ; 1 hour → 30 runs ; 24 hours → 720 runs without interruptions

We made Thousands of non stop runs.

→ **Dakota** find the best parameters (a_1, \dots, a_{12}) to maximize TSR

Main Result :

Video:
 $U=4 \text{ m/s}$

Pitch Off
Then
Pitch On



TSR multiply par 20 with Pitch on !!!!

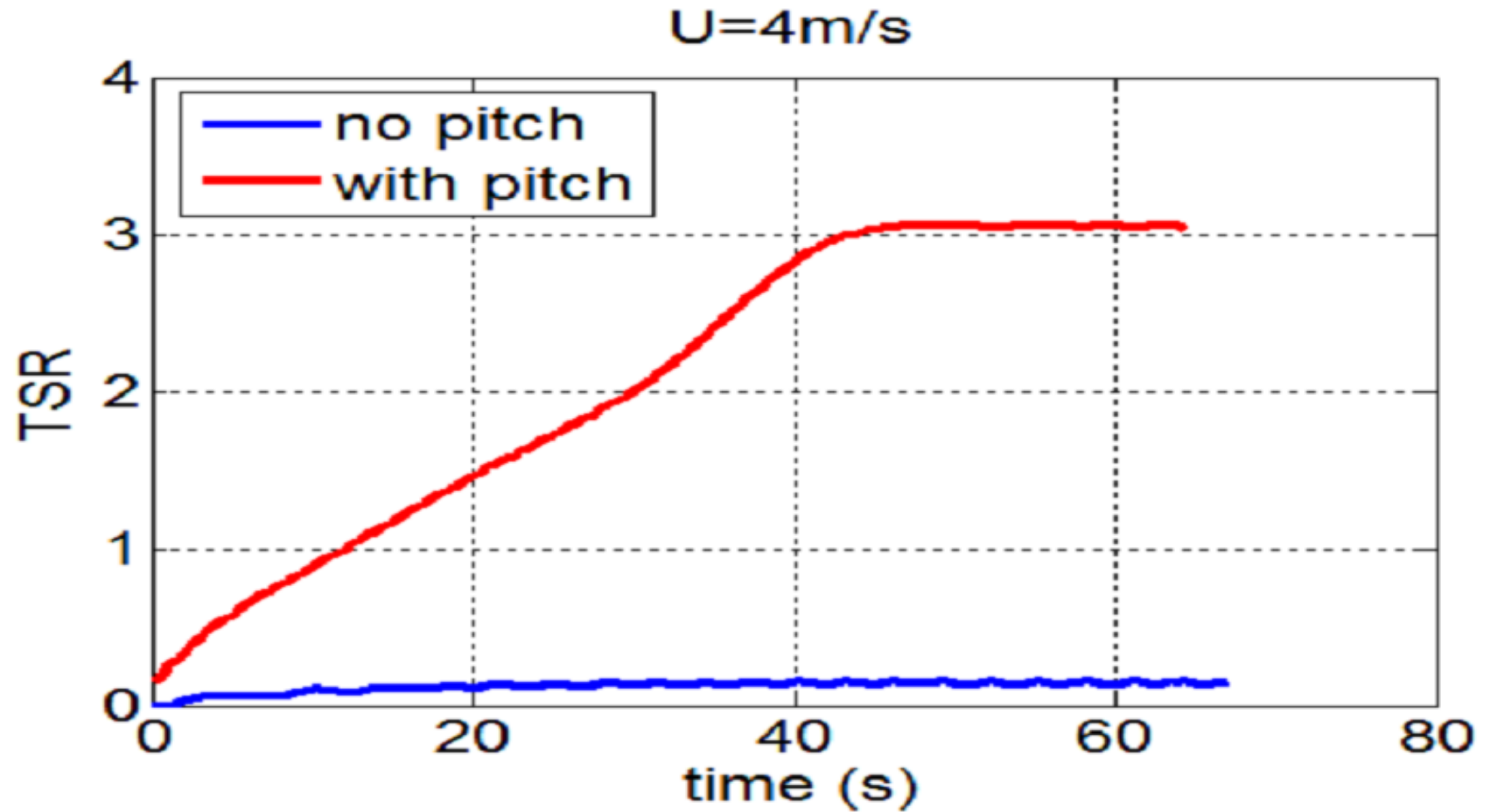

We made PIV measurements to measure the flow around the blades

Air flow is seeded with a lot of particles

camera

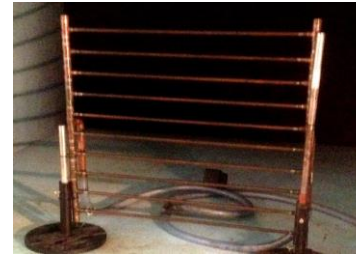

Airbus Helicopter seeding system

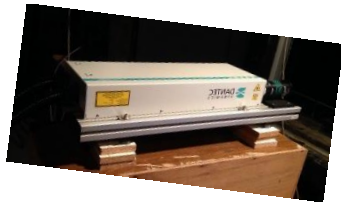

Twin Laser Yag



DANTEC software

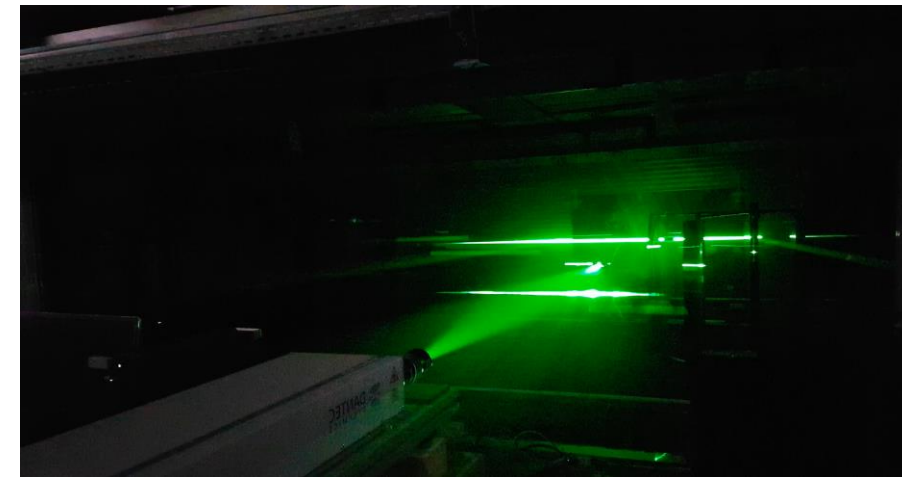
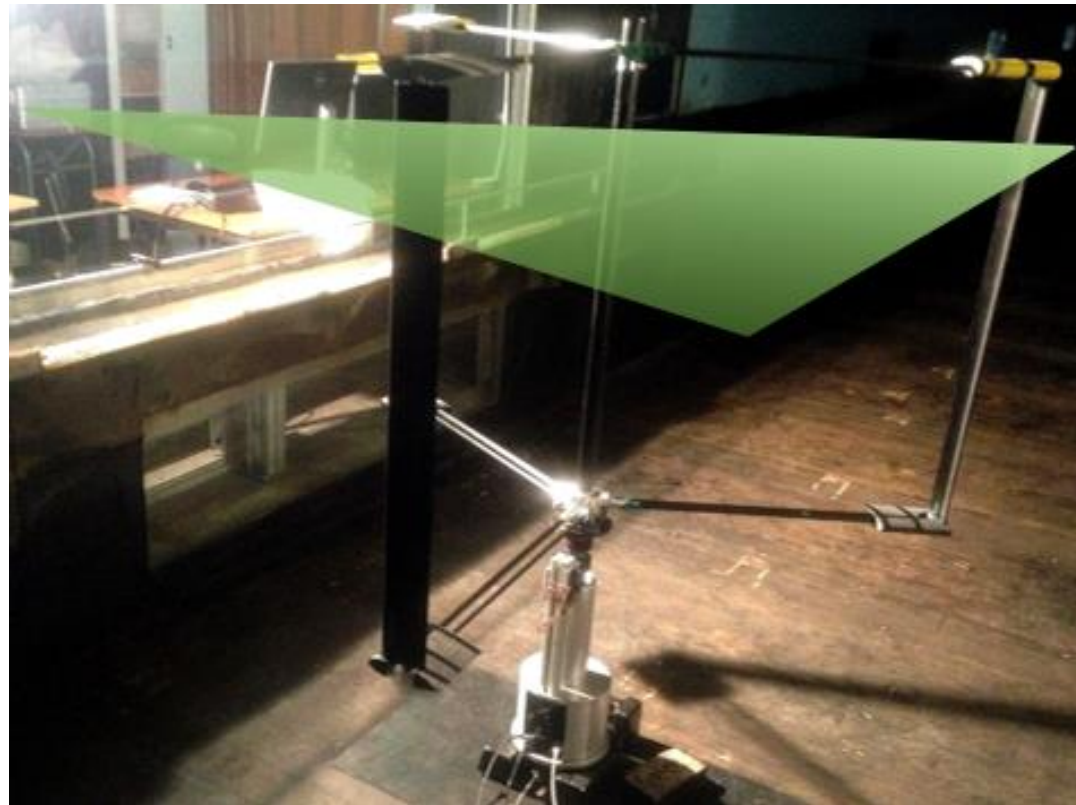

Branger et al, WESC, Cork, June 17-19, 2019

Velocity

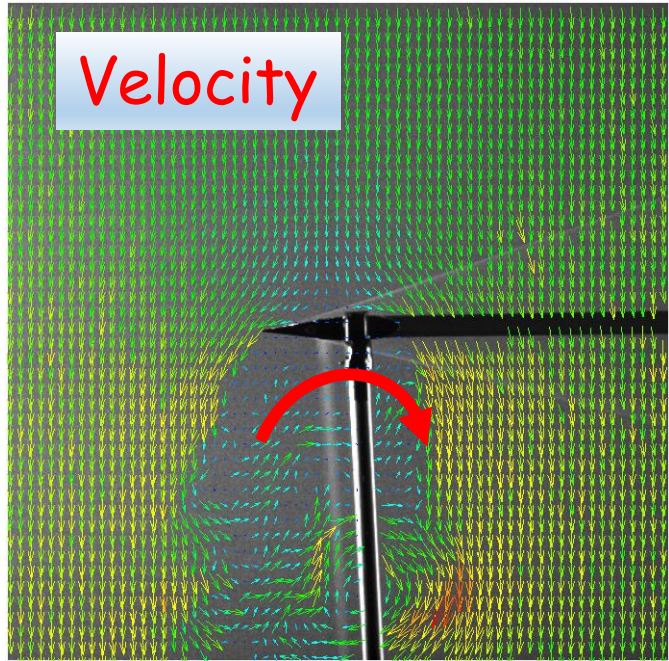

Stream Lines

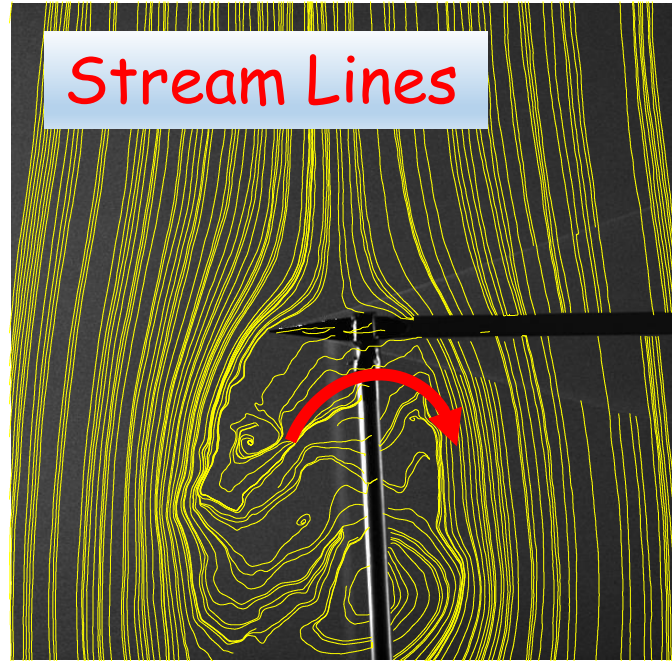

Vorticity

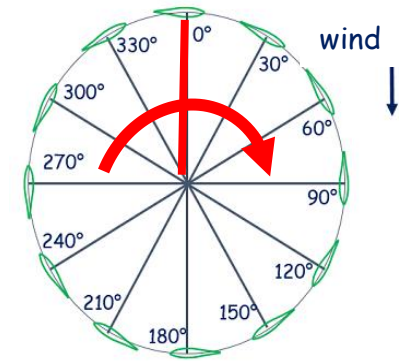
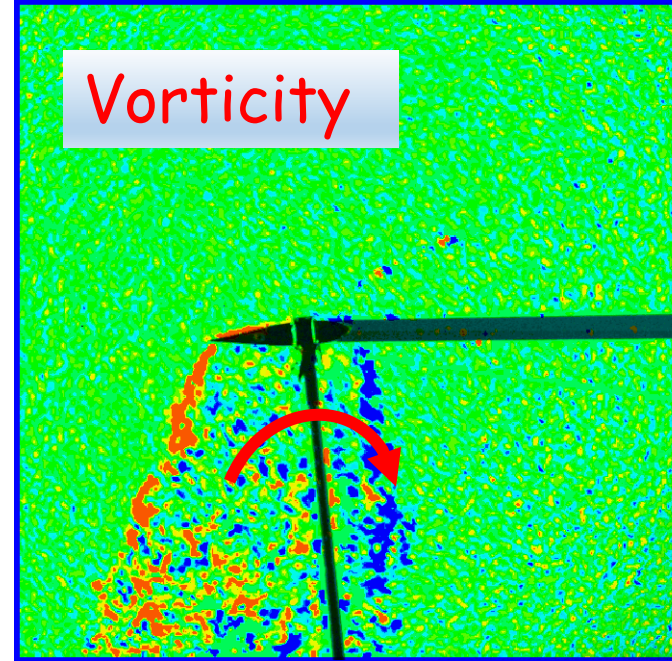

No Pitch

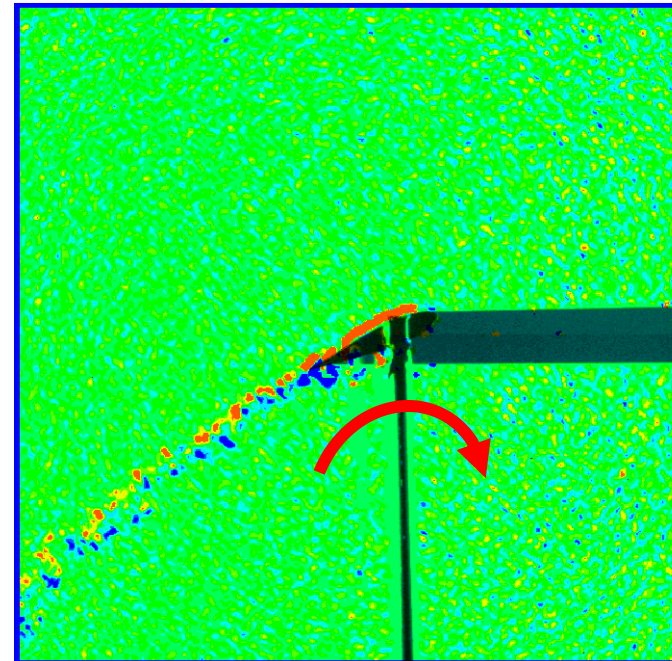
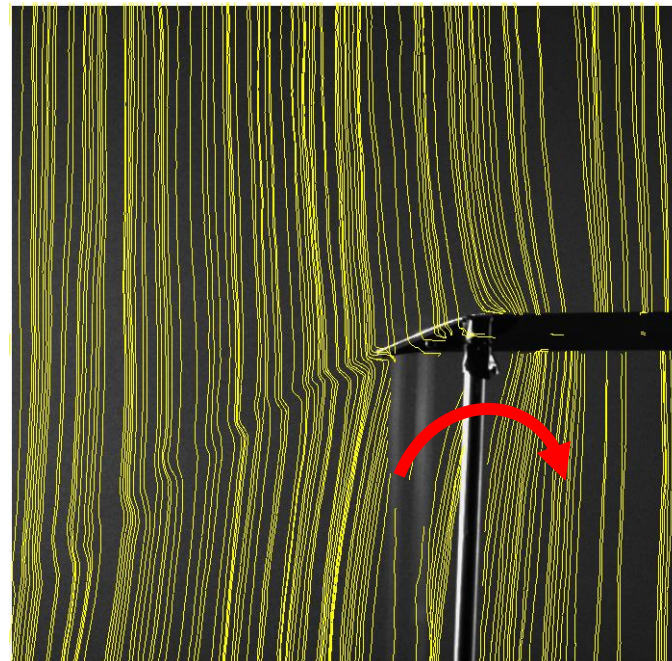
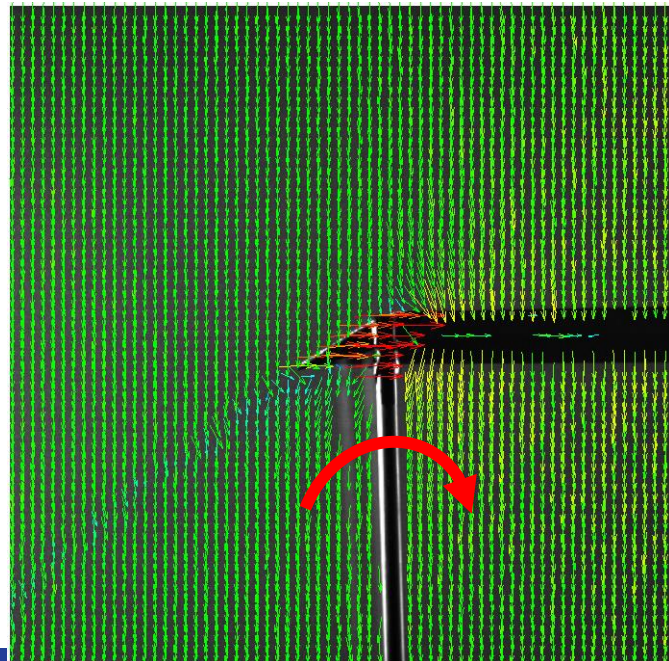

With Pitch

PIV
measurements

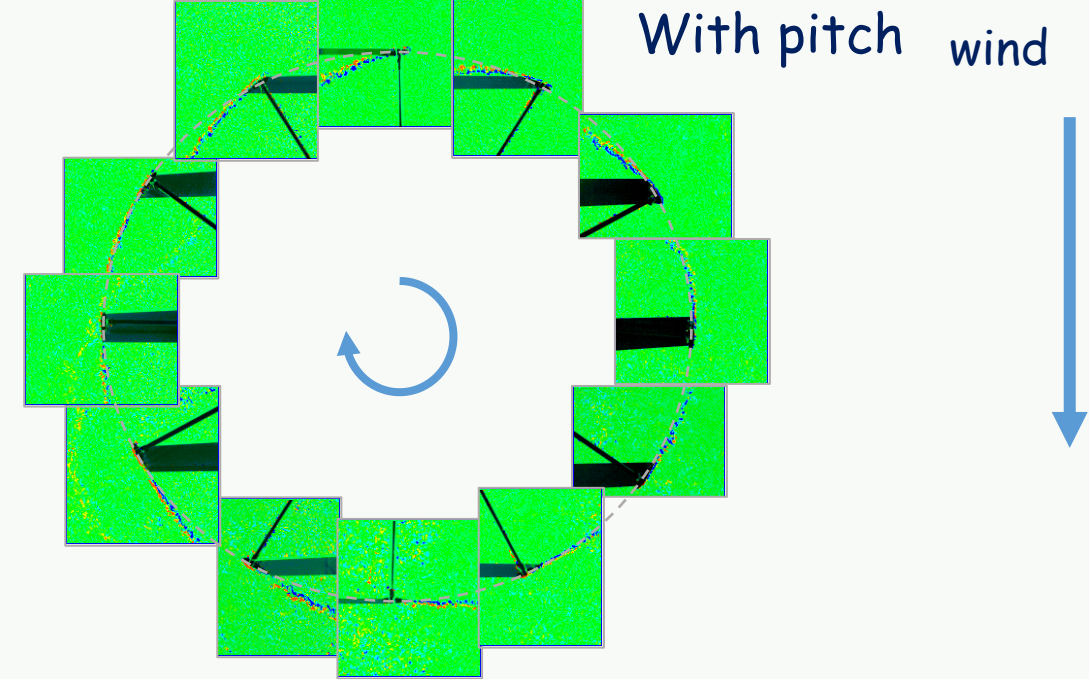
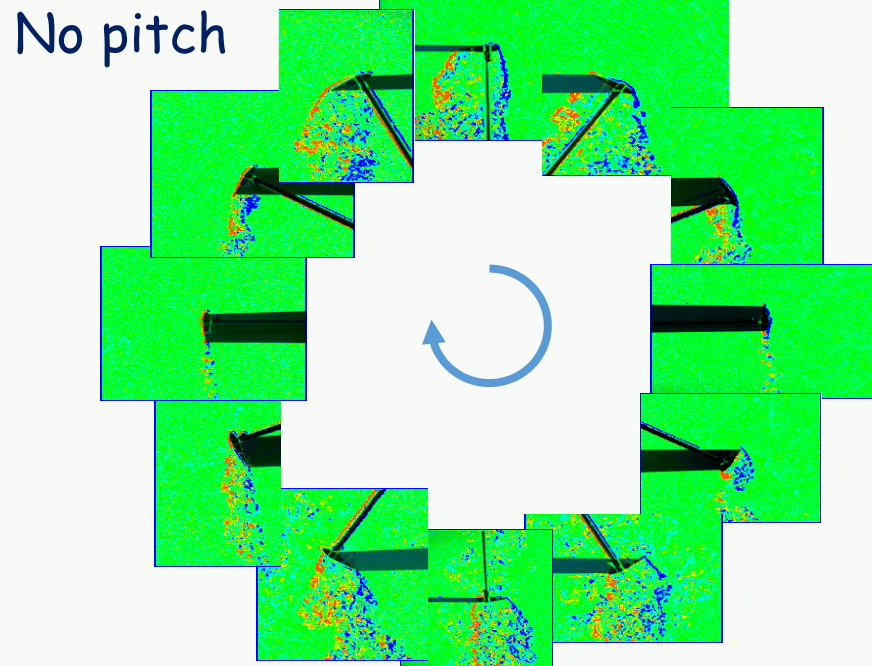

OPEN FOAM
Simulations

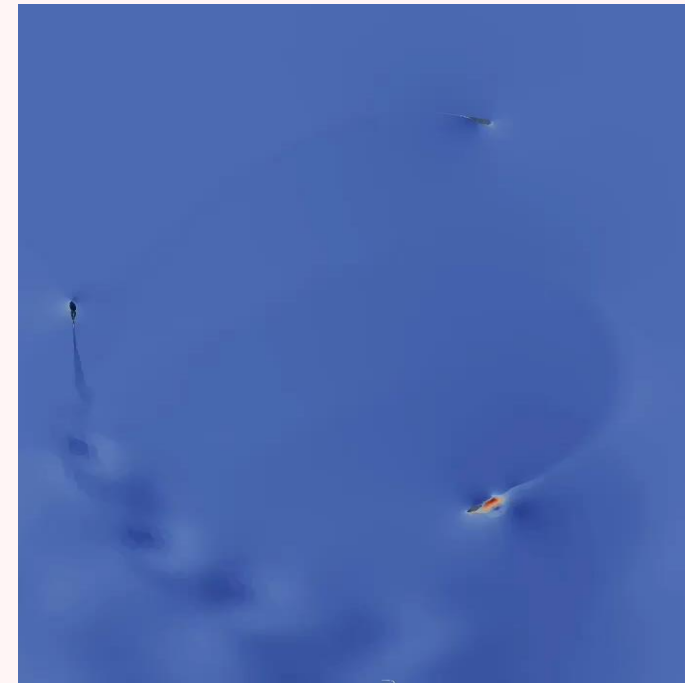

Branger et al, WESC,

Conclusions:

- We build models, conducted experiments, found quite optimized pitching laws
- Pitch:
 - allows self-starting at low wind speed
 - possibility to slow down and stop the turbine
 - increases a lot the rotational velocity (more particularly at low wind speed)
 - increase the Power by 20 % with water turbine

Next: Unfortunately, the two French VAWT projects are canceled 😞

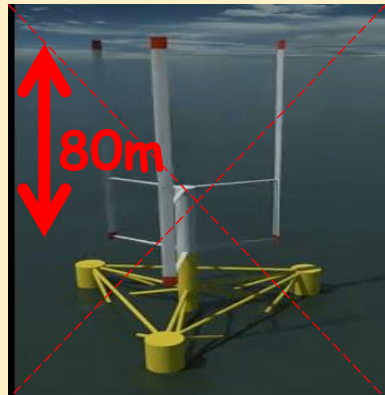

Nenuphar
Vertiwind



Eolfi
Spinfloater

→ New experiments are planned with a Water Turbine with blades completely under the water

Thank You