



**HAL**  
open science

## Dispersed phase structure and micro-explosion behavior under different schemes of water-fuel droplets heating

Dmitry Antonov, Maxim Piskunov, Pavel Strizhak, Dominique Tarlet, Jérôme Bellettre

► **To cite this version:**

Dmitry Antonov, Maxim Piskunov, Pavel Strizhak, Dominique Tarlet, Jérôme Bellettre. Dispersed phase structure and micro-explosion behavior under different schemes of water-fuel droplets heating. *Fuel*, 2020, 259, pp.116241. 10.1016/j.fuel.2019.116241 . hal-02372704

**HAL Id: hal-02372704**

**<https://hal.science/hal-02372704v1>**

Submitted on 26 Feb 2021

**HAL** is a multi-disciplinary open access archive for the deposit and dissemination of scientific research documents, whether they are published or not. The documents may come from teaching and research institutions in France or abroad, or from public or private research centers.

L'archive ouverte pluridisciplinaire **HAL**, est destinée au dépôt et à la diffusion de documents scientifiques de niveau recherche, publiés ou non, émanant des établissements d'enseignement et de recherche français ou étrangers, des laboratoires publics ou privés.

# Dispersed phase structure and micro-explosion behavior under different schemes of water-fuel droplets heating

*Dmitry Antonov<sup>1</sup>, Maxim Piskunov<sup>1</sup>, Pavel Strizhak<sup>1</sup>, Dominique Tarlet<sup>2\*</sup>, Jérôme Bellettre<sup>2</sup>*

<sup>1</sup>*National Research Tomsk Polytechnic University, Heat Mass Transfer Simulation Laboratory, Russia, 30, Lenin Avenue, Tomsk, 634050, Russia. +7(3822)701-777, ex. 1910*

<sup>2</sup>*Laboratoire de Thermique et Énergie de Nantes (LTeN), CNRS UMR 6607, Université de Nantes, Rue Christian Pauc, BP 50609, 44306 Nantes cedex 3, France.*

*\*E-mail: dominique.tarlet@univ-nantes.fr*

## Abstract

One of the known and still unsolved problems of internal combustion engines and liquid fuel power plants is the complexity of efficient (i.e. with minimal cost of basic resources: time, energy and raw materials) ignition of fuels issued from valorization of waste. A promising way to improve the efficiency of ignition of liquid fuels is a secondary atomization using the micro-explosion of water-fuel droplets. This phenomenon is called micro-explosion when concerning an individual water-in-oil emulsion drop among the combusting spray. This process dramatically accelerates fuel heating and ignition, since fuel droplets issued from the secondary atomization are smaller and faster, increasing interfacial area. To investigate the atomization efficiency and its causes, the present work quantifies the occurrence of successful micro-explosion under large samples of experimental data. The behavior of water-fuel drops in the form of fine, middle-size emulsions or two immiscible liquids is observed using schemes with conductive, convective or radiative heat transfer provided at the same range of temperature.

**Keywords:** emulsion drop, alternative fuels, two-component droplets, water, micro-explosion.

## Nomenclature and Units

$D_{in}$  – mean average diameter of the inside water phase, m;

$D_d$  – initial diameter of the emulsion drop, m;

$nb$  - number of reproduced experiments;

$q_{cond}$  – conductive heat flux, kW/m<sup>2</sup>;

$q_{conv}$  – convective heat flux, kW/m<sup>2</sup>;

$q_{rad}$  – radiative heat flux, kW/m<sup>2</sup>;

$R_d$  – initial radius of the droplet, mm;

$S$  – total area of evaporation surface, mm<sup>2</sup>;

$S_0$  – initial area of the evaporating drop, mm<sup>2</sup>;

$t$  – time, s;

$T_a$  – air flow temperature, °C;

$T_s$  – surface temperature of the droplet, °C;  
 $T_{\text{sub}}$  – copper substrate surface temperature, °C;  
 $U_a$  – air flow velocity, m/s;  
 $V_d$  – initial drop volume,  $\mu\text{l}$ .

## Greek

$\alpha$  – heat transfer coefficient,  $\text{W}/(\text{m}^2 \cdot ^\circ\text{C})$ ;  
 $\varepsilon_d$  – emissivity factor of water droplet;  
 $\varepsilon_a$  – emissivity factor of air;  
 $\lambda$  – thermal conductivity,  $\text{W}/(\text{m} \cdot ^\circ\text{C})$ ;  
 $\gamma$  – volume concentration of water in the fuel drop, %;  
 $\nu$  – kinematic viscosity,  $\text{m}^2/\text{s}$ ;  
 $\rho$  – density,  $\text{kg}/\text{m}^3$ ;  
 $\sigma$  – Stefan-Boltzmann constant,  $\text{W}/(\text{m}^2 \cdot ^\circ\text{C}^4)$ .

## 1. Introduction

The main problems of utilization of a liquid fuel in such industries as transport, heat power engineering, chemical and petrochemical industries and others are stable flaming and ecologically efficient burning [1]. Solving these problems, it is possible to attain more rational use of energy and to decrease the negative effect on the environment significantly. These environmental issues have drawn attention to the combustion of emulsified fuels as an efficient way to improve the combustion process [2], and to reduce pollutant emissions as well [3]. There is a group of studies about igniting and burning of hydrocarbon [4], organic coal-water [5], and oil-water [6] fuels. A decrease in the concentration of the sulfur and nitrogen oxides can be reached due to their interaction with the water vapor. Coal or fuel oil have surely a higher combustion heat as compared to the mentioned alternative fuels. Nevertheless, if we need to decrease anthropogenic emissions considerably, then one of the most efficient ways is to add water to the fuel. The phenomenon of micro-explosion [7] that happens in a drop of emulsified fuel is related to the secondary atomization [8] noticed in a spray of such emulsion drops, significantly improving its combustion characteristics [9]. The controlled breakup of fuel droplets containing water will promote to enhance spraying in combustion chambers. Thus, the igniting and burning of fuel emulsions and suspensions will occur more efficiently, with less risk of incomplete burning of fuel and at lower atmospheric emissions of pollutants.

To study micro-explosion at the scale of a unique fuel drop, efforts have been made [10] to identify both the external and internal parameters, i.e. water phase structure, heating temperature etc. that guarantee an optimal disintegration [11]. Such an optimal disintegration is illustrated in Fig. 1. It is first defined by its short duration (less than 1 ms. Mura *et al.* [12]) and by a maximum number of produced

secondary droplets. Watanabe *et al.* [11] distinguish between micro-explosion that fragments the whole emulsion drop, and puffing that is only a partial disintegration. The characteristics of an optimal micro-explosion have been further explored in [13].

Experimental campaigns focusing on the behavior of a heated water-fuel emulsion drop [11, 13–15] together with in-depth numerical investigations [16] are exploring small scales of space and time to identify and explain the phenomena resulting in a reproducible, optimal micro-explosion. Studies [13–16] discuss that aggregation and coalescence of dispersed water droplets considerably influence heating, evaporation, and explosive disintegration of the emulsion droplets. Thus, it allows a significant change of the limit heating temperature and the threshold oil concentration in the emulsion to attain the required breakup mode.

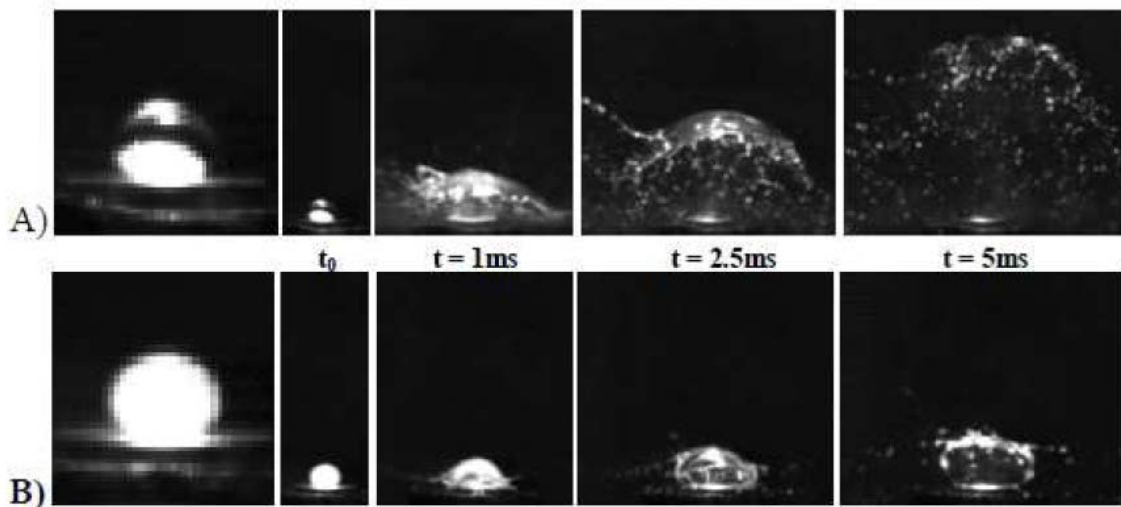

**Fig. 1.** Micro-explosion of an water-in-oil emulsion drop [12] - A : Optimal micro-explosion, B: Non-optimal disintegration.

We can conclude that an experimental database on the conditions of the explosive breakup, its quantitative and temporal characteristics is needed to develop physical and mathematical models to apply in designing and adjusting the heat and mass transfer equipment. Research [17] explains the reasons for the creation of such models.

The present study gathers a large amount of experimental data concerning heated individual water-fuel emulsion drops. Their lifetime is recorded by a camera, enabling to distinguish successful micro-explosion -or not. The drops undergo one scheme of heating (conductive, convective and radiative) provided at the same temperature range. It is easy to set up an experimental test bench using conductive heating, whereas convective and radiative heating are dominant in industrial-scale spray combustion. These emulsion drops have different structures of their internal phase: a fine emulsion that is already

known to prevent coalescence [12,14], a larger emulsion that is known as promoting an inside coalescence [12,14], and two-component emulsion drop where coalescence is already achieved.

To sum up, the purpose of this work is to experimentally determine the occurrence and efficiency of explosive disintegration of the heated water-fuel droplets when adding water, as a result of its internal parameters and heat transfer conditions.

## **2. Experimental setup and procedure**

The present experimental study aims at testing separately different water-fuel droplets that are more or less favorable to coalescence of inside water under each of the three heating schemes. This is important since water coalescence is regarded as essential among the physical processes resulting in an optimal micro-explosion [13,15,16]. Since many thermal and physical processes are interacting together in the heated water-fuel drop, reproducibility of experiments is also taken into account. Thus, each configuration is tested 10 times minimum on the experimental bench.

These emulsion drops have different structures of their internal phase. First, Fig. 2 depicts a fine and rather homogeneous emulsion (mean diameter of 1.2  $\mu\text{m}$ ) that is already known to prevent coalescence [12,14]. This is due to the difficult aggregation of small ( $\sim 1 \mu\text{m}$ ) water droplets with a high Laplace pressure, into another one being the same diameter. Second, a larger and more heterogeneous emulsion (4 to 8  $\mu\text{m}$ , mean diameter 6  $\mu\text{m}$ ) is tested under conductive heating. This emulsion is more likely to promote water coalescence, since a difference in diameter generates a difference in Laplace pressure, pushing the high-pressure small droplet into the bigger one. For this reason, this range of mean diameter of water inclusions has been tested a large number of times, and called the optimal emulsion for micro-explosion [12,14]. Third, two-component water-fuel drops are also tested, where the water inclusion is a unique droplet generated by a pipette. In this third kind of water-fuel drop, inside water coalescence is already achieved from the beginning. This two-component configuration with a big, unique inside water droplet has been tested before in another experimental facility [15] to investigate water coalescence.

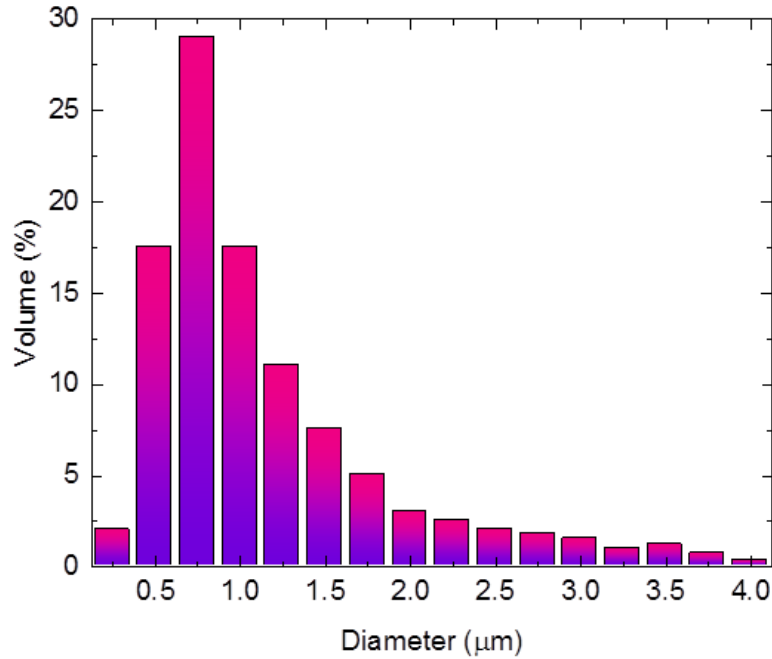

**Fig. 2.** Sub-droplets diameter distribution within the fine emulsion based on three repeated measurements.

### 2.1. Producing the tested emulsion droplets

Distilled water (density  $\rho \approx 997 \text{ kg/m}^3$  and viscosity  $\nu \approx 0.96 \cdot 10^{-6} \text{ m}^2/\text{s}$ ) was used in the experiments. The main studied substance was fuels and flammable liquids (Table 1): tetradecane; rapeseed oil; diesel. The  $6 \mu\text{m}$ -emulsion with 5% wt. of water was produced as documented in [12,14].

**Table 1.** Typical properties of the considered fuels and flammable liquids.

Liquid	Density at 20°C, $\text{kg/m}^3$	Kinematic viscosity at 25°C, Cst	Flash point, °C	Ignition temperature, °C	Heat of combustion, MJ/kg	Boiling temperature, °C	Heat of evaporation, MJ/kg
tetradecane	762	2.8	100	202	47.5	254	0.36
rapeseed oil	920	75	107	260	42.1	204	0.209
diesel	820	15	57–67	300	42.4	240–347	0.210

The volume concentration of water ( $\gamma$ ) in the investigated inhomogeneous (two-liquid) drops is 10% in accordance with three main applications [17–20]: gasification of water fuel emulsions; thermal purification of liquids from unspecified impurities; creation of fuel emulsions with the use of waste oils, oil sludge, industrial effluents, etc.

The two-component drop was placed in the quartz cylinder using a motorized linear actuator. Three holes with a diameter of 10 mm were made in the measuring area for introducing the drop into the quartz hollow cylinder, illuminating and video recording its heating and evaporation processes. Video recording of the inhomogeneous droplet heating began at reaching the last axis of symmetry of cylindrical

quartz channel 10. The process of the droplet movement from the moment of entering in channel 10 (the wall of the quartz cylinder) to its symmetry axis was about 1 s. The initial time ( $t=0$  s) is understood as a moment when the drop has reached the centre (the symmetry axis) of the quartz channel.

To generate droplets of the desired diameters, two dispensers, Finnpiptette Novus Pipettes, were used (variation step of the generated volume of 0.1  $\mu\text{l}$ ). The initial volume of the two-component drop in the experiments varied within  $V_d=10\text{--}25$   $\mu\text{l}$ . This corresponded to the variation range of the radius  $R_d=1.3\text{--}1.8$  mm. A drop of liquid fuel component was suspended on the holder. Further, a drop of water was placed on this drop by means of the second dispenser.

## 2.2. Test benches for the three heating schemes

Two experimental facilities are used in this study (Fig. 3). The emulsion drop is maintained on a heated plate using the Leidenfrost effect [14]. This phenomenon results on the rapid vaporization of the bottom layer of a droplet, creating a thin vapor film, thermally insulating the droplet. The hot plate illustrated in the Fig. 3b can achieve a temperature between 450 °C and 500 °C, which is higher than the Leidenfrost temperature [12]. It is made of aluminum, and its diameter is 0.6 cm. Temperature is measured by an 80  $\mu\text{m}$  K-type thermocouple with a measurement error of  $\pm 1.5^\circ\text{C}$ . The 6  $\mu\text{m}$ -emulsion with 5% wt. water in tetradecane is tested on this Leidenfrost test bench shown on Fig. 3b. Whereas two-component and 1.2  $\mu\text{m}$ -emulsions are tested on the conductive heated substrate fully documented in [18-20] that is also maintained at 450°C. The experimental stand with convective or radiative heating schemes shown on Fig. 3a. A hollow metal rod with an inner and outer diameter of 0.5 mm and 0.8 mm, respectively, was used as a drop holder in the experiments. In [18], the feasibility of such holder application in comparison with wires and other rods was substantiated (the latter had a significant effect on the rate of heating and evaporation of droplets of homogeneous and multicomponent fluids).

The heat fluxes have been calculated as follows: convective –  $q_{\text{conv}} = \alpha \cdot (T_a - T_s)$ , conductive heat flux in the case of the droplet being heated on a substrate –  $q_{\text{cond}} = \frac{\lambda(T_{\text{sub}} - T_s)}{R_d}$ , radiative –  $q_{\text{rad}} = (\varepsilon_d \cdot \sigma \cdot (T_a^4 - T_s^4) + \varepsilon_a \cdot \sigma \cdot T_a^4)$ . The quantitative values of heat fluxes might vary within the corresponding limits at  $T=450\text{--}500$  °C:  $q_{\text{conv}}=60\text{--}70$  kW/m<sup>2</sup>;  $q_{\text{cond}}=70\text{--}200$  kW/m<sup>2</sup>;  $q_{\text{rad}}=15\text{--}20$  kW/m<sup>2</sup>. In each heating scheme, three heat fluxes existed but only one dominated. During computation, the assumptions concerning the optical properties of the drops and the gaseous environment were admitted according to [19]. The heat fluxes values can change following to the findings discussed in [21] but their trends will remain unchanged. At the wavelengths for temperatures of the micro-explosion phenomenon, an index of absorption corresponds to the values of the order of  $10^4$  m<sup>-1</sup>. The index of absorption was calculated by using a dimensionless absorption coefficient provided in [22]. Water absorbs the external

radiation partially and, consequently, the transmitted part accumulates at the interfaces inside the tested droplets [23].

The research methods are similar to those used in studies [18–20]. The main difference of this work from experiments [18–20] is the focus on the effect of adding water to fuel on the conditions and characteristics of heating and evaporation of two-component (two-liquid) drops. It is important to establish the necessary water concentration, as well as the temperature at which the explosive disintegration of a two-component drop can be stable.

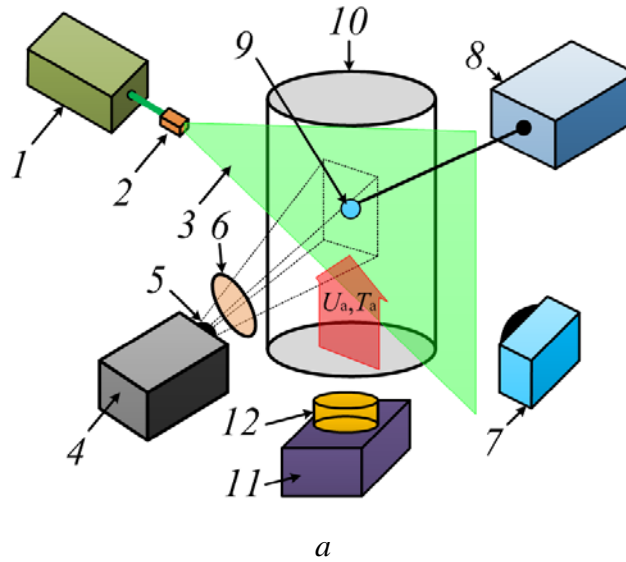

*a*

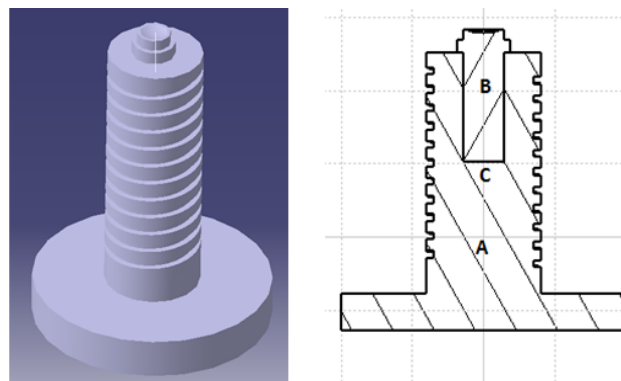

*b*

**Fig. 3.** (a) The scheme of the facility with convective or radiative heating schemes [20]: 1 – pulse laser; 2 – a lens for forming a laser sheet; 3 – laser sheet; 4 – cross-correlation video camera; 5 – macro-lens; 6 – light filter; 7 – high-speed video camera; 8 – motorized linear actuator; 9 – drop; 10 – transparent quartz cylinder; 11 – blower; 12 – heater. (b) The scheme of the Leidenfrost facility [10]: A: Threaded support for the hot wire; B: Droplet holder; C: Position of the 80- $\mu\text{m}$  type-K thermocouple

A system consisting of a blower, a heater, and a hollow transparent cylinder (inner diameter of 0.1 m) of heat-resistant quartz glass was used to generate a flow of heated air with controlled parameters (temperature  $T_a$  and velocity  $U_a$ ). Temperature  $T_a$  was registered by a measuring complex consisting of a high-speed analog input board and a chromel-aluminum fast-response thermocouple. The latter was



placed in the air flow before the drop injection. The motorized linear actuator was used. The velocity of its moving part was 0.5 m/s. The velocity of the air flow  $U_a$  in the quartz cylinder was controlled using the optical *PIV* method [18]. Additional experiments were carried out to blow the tracing particles of titanium dioxide (average size of 5  $\mu\text{m}$ ) into the heated air flow and to register the flow velocity fields of the latter based on the velocities of the dispersed phase elements. The processes of disintegration of two-component drops were studied when they were heated in the air flow with a temperature of 20–1000  $^{\circ}\text{C}$  and a velocity of 0.1–5 m/s.

### 3. Results and discussion

The images recorded by the camera during heating of the emulsion drops enable to discriminate between a successful micro-explosion [10] defined as a sudden and total atomization, and a series of partial puffing phenomena.

#### 3.1. Influence of the emulsion structure

Table 2 shows the obtained results that are very clear under the different heating modes. Two-component water-fuel drops surely undergo a real micro-explosion, whereas the fine and rather homogeneous emulsion, known to prevent water coalescence [12,14] goes into puffing events. However, the 10% vol. water-in-diesel fine emulsion exhibits 40% of micro-explosion. This result shows that the ~80% lower viscosity of diesel fuel compared with rapeseed oil (see Table 1) can enhance micro-explosion in some cases. More generally, the presence of water as a dispersed phase always enables the possibility of a micro-explosion, with a 40% recorded probability in the present case.

The results from Table 2 are shown in Fig. 4, in the form of a graph describing the influence of the initial structure of the emulsion ( $D_{in}/D_d$ ) onto the micro-explosion success rate. A large number of repeated experiments (160 experiments) results in a clearly increasing tendency. The fine emulsion is limited to puffing phenomena, whereas the two-component drops always undergo a successful micro-explosion. The optimal emulsion [12,14], with nearly 80% of micro-explosion over the 50 experiments, shows that the ability to coalescence of the dispersed phase is an essential parameter in the emulsified fuel process, even with different thermo-physical properties of the oil shell (Diesel, Rapeseed oil, Tetradecane). This global tendency is observed under each of the three heating schemes at the present temperature range, between 450 and 470 $^{\circ}\text{C}$ .

**Table 2.** Experimental results. All the configurations were tested 10 times. The 6  $\mu\text{m}$ -emulsion was tested 50 times. Percentages are in volume, unless otherwise indicated.

Heating scheme	Conductive	Convective	Radiative
<i>Micro-explosion success rate</i>			

6 $\mu\text{m}$ -emulsion	5% wt. water in Tetradecane	0.796		
Two-component	10% water in Diesel	1	1	1
	10% water in Rapeseed	1	1	1
1.2 $\mu\text{m}$ -emulsion	10% water in Diesel	0.4	0	0
	10% water in Rapeseed	0	0	0
<i>Emulsion Structure: <math>D_{\text{in}}/D_{\text{d}}</math></i>				
6 $\mu\text{m}$ -emulsion	5% wt. water- Tetradecane	0.05		
Two-component	10% water in Diesel	0.4615	0.4615	0.4615
	10% water in Rapeseed	0.4615	0.4615	0.4615
1.2 $\mu\text{m}$ -emulsion	10% water in Diesel	$4.6 \cdot 10^{-4}$	$4.6 \cdot 10^{-4}$	$4.6 \cdot 10^{-4}$
	10% water in Rapeseed	$4.6 \cdot 10^{-4}$	$4.6 \cdot 10^{-4}$	$4.6 \cdot 10^{-4}$

It should be noted that ( $D_{\text{in}}/D_{\text{d}}$ ) is in a logarithmic scale. The present results (Fig. 4) show that the micro-explosion success rate (M.E.) is actually not a linear function of the initial ratio ( $D_{\text{in}}/D_{\text{d}}$ ), but rather a linear function of its logarithm:  $\ln(D_{\text{in}}/D_{\text{d}})$ . Too small water droplets ( $D_{\text{in}}/D_{\text{d}} \rightarrow 0$ ) cannot undergo all these successive events in the heating duration, leading to a drastically decreasing value of the success rate (M.E.). In this case, the emulsion is too stable to activate coalescence. Two-component drops have already achieved their coalescence events, which results in the maximum value of the success rate (M.E.). At this point, it should be noted that logarithmic behavior was also observed in a previous work [14] concerning the fragmentation of parent emulsion into secondary droplets, leading to a log-normal distribution of their thermal energy. The mathematical meaning of logarithmic behavior is the power applied to a number, in other words successive multiplications of a number. Here, the behavior as a function of  $\ln(D_{\text{in}} / D_{\text{d}})$  suggests that successive multiplications of the diameters of inside water droplets, for example through a series of successive events of coalescence, plays a key role for the successful micro-explosion.

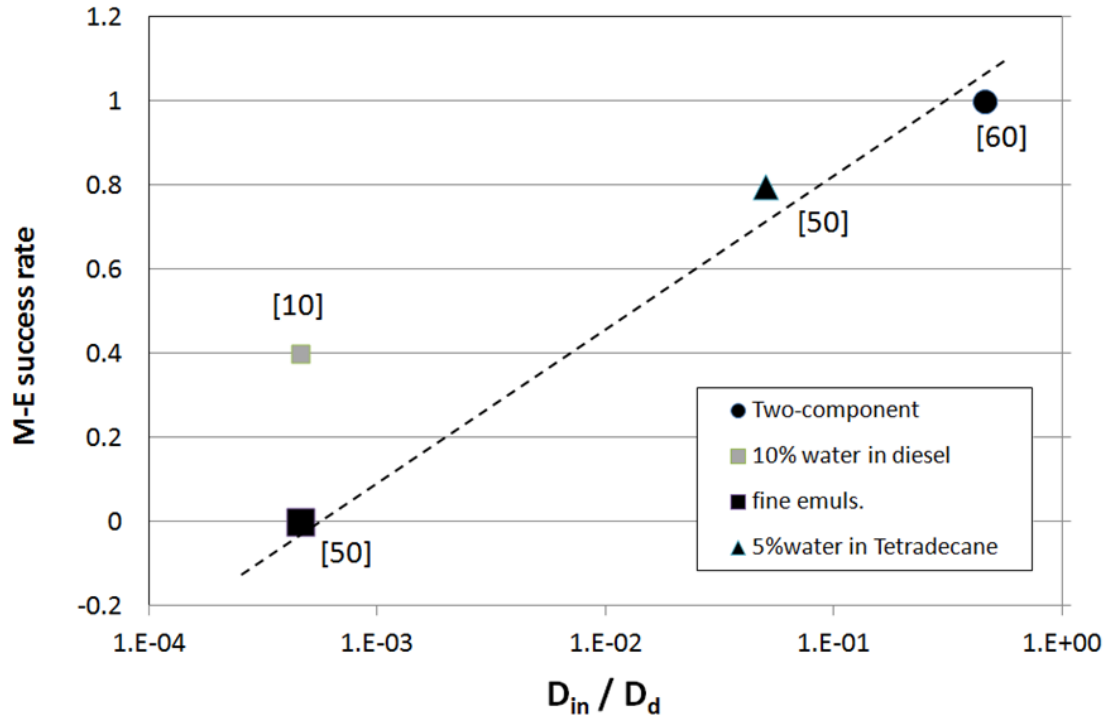

**Fig. 4.** Micro-explosion success rate, as a function of the initial structure of the emulsion. The number of reproduced experiments [nb] is indicated.

### 3.2. Comparison of the lifetimes during heating

Table 3 shows the lifetimes of the heated water-fuel drops until their complete evaporation. Concerning convective or radiative heating schemes, micro-explosion delays are in the same order of magnitude whether micro-explosion is successful (two-component drop) or not (fine emulsion). In these cases with more distant heating modes less powerful than the conductive surface, drops last for some seconds until complete evaporation. Whereas conductive, fast heating enables us to observe a real difference between a succeeded micro-explosion that happens quickly, in less than a second concerning the optimal 6  $\mu\text{m}$ -emulsion and the Two-component. Under conductive heating, the non-optimal puffing sequence reaches an order of magnitude longer, since it lasts for some seconds.

**Table 3.** Lifetimes during heating of water-fuel drops until complete evaporation. All the configurations were tested 10 times. The 6  $\mu\text{m}$ -emulsion was tested 50 times.

Heating scheme		Conductive	Convective	Radiative
<i>Average lifetime [s]</i>				
6 $\mu\text{m}$ -emulsion	5% wt. water-Tetradecane	0.53		
Two-component	10% water in Diesel	0.5466	5.8704	7.0914
	10% water in Rapeseed	0.2333	6.4977	6.8252

1.2 $\mu\text{m}$ -emulsion	10% water in Diesel	3.305	7.185	8.702
	10% water in Rapeseed	5.3374	4.376	7.617

These recorded lifetimes indicate that a conductive test bench for micro-explosion enables to quickly trigger and observe a successful micro-explosion. Although its powerful and fast heating significantly differs from the distant convective and radiative heating that are dominant within industrial spray combustion where temperatures are as high as 2000 K.

### 3.3. Efficiency of the obtained atomization

At the atomization, a sample of child-droplets is visualized using the optical camera (see Section 2.2). The number of child-droplets in the sample is between 9 and 19. Their diameter distribution is taken into account to calculate the sum of the surfaces and the volumes of the child-droplets in the sample (typical frames have been presented in Fig. 5). Then, the increase in the interfacial area ( $S/S_0$ ) is calculated, supposing that this recorded distribution of diameters is the same among all the child-droplets. Table 4 shows the obtained increase in interfacial area ( $S/S_0$ ) in the present cases. It is nearly one order of magnitude higher in all cases, even when puffing is observed. These results illustrate the significant improvement of water-fuel spray combustion, based on 120 repeated experiments under the different heating modes.

**Table 4.** The increase in interfacial area ( $S/S_0$ ). All the configurations were tested 10 times.

Heating scheme		Conductive	Convective	Radiative
$(S/S_0)$				
Two-component	10% water in Diesel	10.72	8.40	15.49
	10% water in Rapeseed	11.90	11.43	6.86
1.2 $\mu\text{m}$ -emulsion	10% water in Diesel	9.66	20.44	11.38
	10% water in Rapeseed	12.51	9.60	7.03

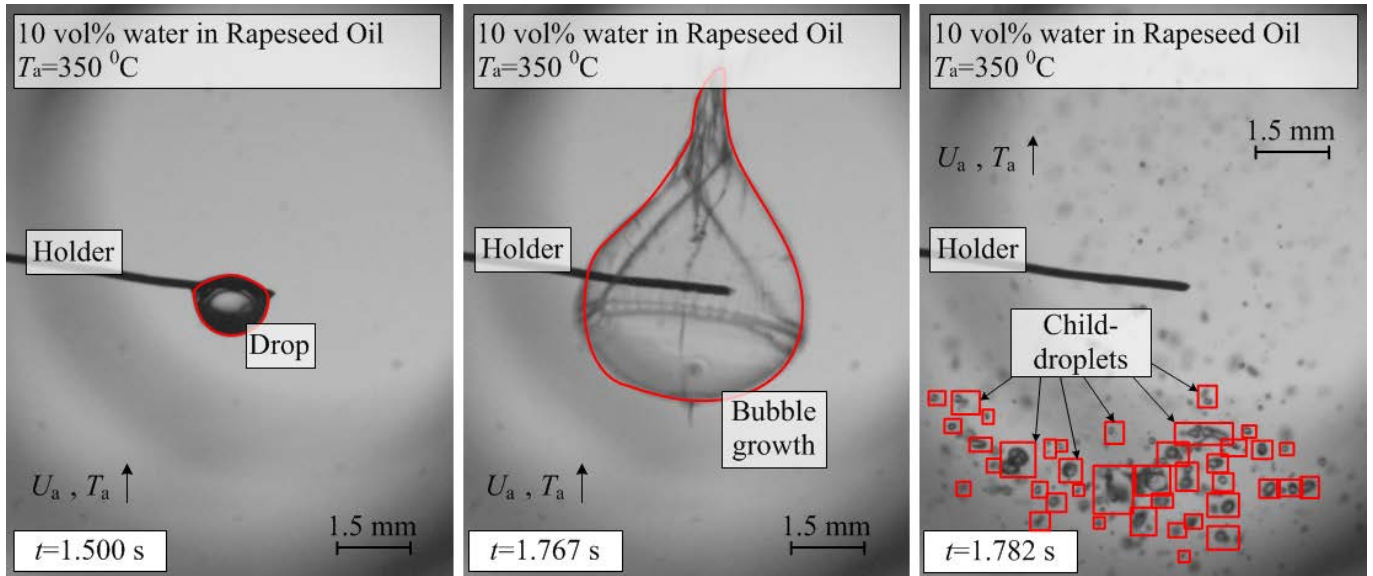

**Fig. 5.** Typical frames with child-droplets.

#### 4. Conclusions

The present experimental campaign was conducted using chosen alternative fuels and range of temperature under the different modes of heating. These experiments were successfully reproducible in the present range of heating parameters and intrinsic properties.

(i) The conducted experiments allowed us to establish the influence of  $\ln(D_{in}/D_d)$  upon the occurrence of micro-explosion under all heating modes. It confirms the principle of successive events of coalescence [10–14] leading to a successful micro-explosion.

(ii) The increase in interfacial area ( $S/S_0$ ) is nearly one order of magnitude, even when a sequence of puffing is observed. A remarkable fact is that it does not depend on the heating scheme. This is important for spray combustion, since convective and radiative heat transfers are dominant in this situation.

(iii) The lifetime of the heated water-fuel drop differs between successful micro-explosion and puffing only on the conductive heat bench. At the present temperature range, convective and radiative heat transfers are promoting a more distant, slower heating that does not cause a significant difference between the lifetimes when micro-explosion or puffing are observed.

#### Acknowledgments

Work on this paper was supported by National Research Tomsk Polytechnic University (project VIU–ISHFVP–60/2019) (contributions by Pavel Strizhak, Maxim Piskunov, Dmitry Antonov). It was also supported by the Région Pays de la Loire (Chaire Connect Talent ODE) concerning contributions by Dominique Tarlet and Jérôme Bellettre.

#### References

- [1] N. Lior, Energy resources and use: The present situation and possible paths to the future, *Energy* 33 (2015) 842–857.
- [2] M.A. Ismael, M.R. Heikal, A.R. Aziz, C. Crua, M. El-Adawy, Z. Nissar, M.B. Baharom, E.Z. Zainal, Firmansyah, Investigation of Puffing and Micro-Explosion of Water-in-Diesel Emulsion Spray Using Shadow Imaging, *Energies* 11 (2018) 2281.
- [3] M. Senthil Kumar, A. Kerihuel, J. Bellettre, M. Tazerout, Ethanol animal fat emulsions as a diesel engine fuel – Part 2: Engine test analysis, *Fuel* 85 (17–18) (2006) 2646–2652.
- [4] V. Syrodoy, G. Kuznetsov, A. Zhakharevich, N. Gutareva, S. Salomatov, The influence of the structure heterogeneity on the characteristics and conditions of the coal–water fuel particles ignition in high temperature environment, *Combustion and Flame* 180 (2017) 196–206.
- [5] M.A. Dmitrienko, P.A. Strizhak, Coal-water slurries containing petrochemicals to solve problems of air pollution by coal thermal power stations and boiler plants: An introductory review, *Science of the Total Environment* (613–614) (2018) 1117–1129.
- [6] B. Kichatov, A. Korshunov, K. Son, E. Son, Combustion of emulsion-based foam, *Combustion and Flame* 172 (2016) 162–172.
- [7] T. Kadota, H. Yamasaki, Recent advances in the combustion of water fuel emulsion, *Progress in Energy and Combustion Science* 28 (5) (2002) 385–404.
- [8] J. Ballester, C. Dopazo, P. Vidal, L. Ojeda, Large-scale laboratory experiments on pollutant emissions in heavy oil combustion 2 (1995).
- [9] H. Watanabe, Y. Shoji, T. Yamagaki, J. Hayashi, F. akamatsu, K. Okazaki, Observation of droplet behavior of emulsified fuel in secondary atomization in flame, *Journal of Thermal Science and Technology* 9 (2) (2014).
- [10] O. Moussa, D. Tarlet, P. Massoli, J. Bellettre, Parametric study of the micro-explosion occurrence of W/O emulsions, *International Journal of Thermal Sciences* 133 (2018) 90–97.
- [11] H. Watanabe, T. Harada, Y. Matsushita, H. Aoki, T. Miura, The characteristics of puffing of the carbonated emulsified fuel, *International Journal of Heat and Mass Transfer* 52 (2009) 3676–3684.
- [12] E. Mura, C. Josset, K. Loubar, G. Huchet, J. Bellettre, Effect of dispersed water droplet size in microexplosion phenomenon for water in oil emulsion, *Atomization and Sprays* 20 (9) (2010) 791–799.
- [13] Y. Suzuki, T. Harada, H. Watanabe, M. Shoji, Y. Matsushita, H. Aoki, T. Miura, Visualization of aggregation process of dispersed water droplets and the effect of aggregation on secondary atomization of emulsified fuel droplets, *Proceedings of the Combustion Institute* 33 (2) (2011) 2063–2070.
- [14] D. Tarlet, E. Mura, C. Josset, J. Bellettre, C. Allouis, P. Massoli, Distribution of thermal energy of child-droplets issued from an optimal micro-explosion, *International Journal of Heat and Mass Transfer* 77 (2014) 1043–1054.
- [15] D. Tarlet, C. Josset, J. Bellettre, Comparison between unique and coalesced water drops in micro-explosions scanned by differential calorimetry, *International Journal of Heat and Mass Transfer* 95 (2016)

689–692.

- [16] J. Shinjo, J. Xia, L. C. Ganippa, A. Megaritis, Physics of puffing and microexplosion of emulsion fuel droplets, *Physics of Fluids* 26 (10) (2014).
- [17] S.S. Sazhin, Modelling of fuel droplet heating and evaporation: Recent results and unsolved problems, *Fuel* 196 (2017) 69–101.
- [18] R.S. Volkov, P.A. Strizhak, Using Planar Laser Induced Fluorescence to explore the mechanism of the explosive disintegration of water emulsion droplets exposed to intense heating, *International Journal of Thermal Sciences* 127 (2018) 126–141.
- [19] P.A. Strizhak, M.V. Piskunov, R.S. Volkov, J.C. Legros, Evaporation, boiling and explosive breakup of oil-water emulsion drops under intense radiant heating, *Chemical Engineering Research and Design* 127 (2017) 72–80.
- [20] R.S. Volkov, P.A. Strizhak, Planar laser-induced fluorescence diagnostics of water droplets heating and evaporation at high-temperature, *Applied Thermal Engineering* 127 (2017) 141–156.
- [21] Sazhin S. *Droplets and sprays*. London: Springer-Verlag; 2014.
- [22] G.M. Hale, M.P. Querry, Optical constants of water in the 200-nm to 200- $\mu\text{m}$  wavelength region, *Applied Optics* 12 (3) (1973) 555–563.
- [23] G.V. Kuznetsov, K.Y. Osipov, M.V. Piskunov, R.S. Volkov, Experimental research of radiative heat transfer in a water film, *International Journal of Heat and Mass Transfer* 117 (2018) 1075–1082.