



HAL
open science

Hybridating vertex and face normals to design torsion-free gridshells: application to the X-Mesh pavilion

Xavier Tellier, Sonia Zerhouni, Guillaume Jami, Alexandre Le Pavec, Thibault Lenart, Mathieu Lerouge, Nicolas Leduc, Cyril Douthe, Laurent Hauswirth, Olivier Baverel

► To cite this version:

Xavier Tellier, Sonia Zerhouni, Guillaume Jami, Alexandre Le Pavec, Thibault Lenart, et al.. Hybridating vertex and face normals to design torsion-free gridshells: application to the X-Mesh pavilion. FORM and FORCE - Proceedings of the IASS 2019 Symposium, 2019, 978-84-121101-0-4. hal-02368564

HAL Id: hal-02368564

<https://hal.science/hal-02368564v1>

Submitted on 18 Nov 2019

HAL is a multi-disciplinary open access archive for the deposit and dissemination of scientific research documents, whether they are published or not. The documents may come from teaching and research institutions in France or abroad, or from public or private research centers.

L'archive ouverte pluridisciplinaire **HAL**, est destinée au dépôt et à la diffusion de documents scientifiques de niveau recherche, publiés ou non, émanant des établissements d'enseignement et de recherche français ou étrangers, des laboratoires publics ou privés.

Hybridizing vertex and face normals to design torsion free structures: application to the X-mesh pavilion

Xavier TELLIER^{a,b}, Sonia ZERHOUNI^{c,*}, Guillaume JAMI^c, Alexandre LE PAVEC^c, Thibault LENART^c, Mathieu LEROUGE^a, Nicolas LEDUC^{a,c}, Cyril DOUTHE^a, Laurent HAUSWIRTH^b, Olivier BAVEREL^{a,d}

*^c ENS Architecture Paris Malaquais
sonia.zerhouni@paris-malaquais.archi.fr

^a Laboratoire Navier UMR8205, Ecole des Ponts, IFSTTAR, CNRS

^b Université Paris-Est, Laboratoire d'Analyse et de Mathématiques Appliquées

^d GSA / ENS Architecture Grenoble

Abstract

The fabrication of a freeform structural envelope is usually a highly complex task. The costliest aspect is often the connections between the constitutive parts. X-Mesh is a pavilion that demonstrates a new rationalization strategy. Its structure, composed of a hexagonal grid of beams and cladding panels, is based on a geometry that rationalizes connections at two levels: firstly, nodes are repetitive, only two types of nodes are used. Secondly, panels can easily be connected to the support beams as they are orthogonal to each other. We prove that the proposed geometrical configuration can be asymptotically built on a smooth surface. We generate the meshes by numerical optimization from a smooth target surface, with an initialization derived from the asymptotic case. This pavilion shows another way of rationalizing a gridshell beyond the popular planar-quad meshes and circular/conical meshes. It also demonstrates a way to generate hexagonal gridshells which are not necessarily synclastic, this limitation being typically imposed to achieve planarity of cladding panels.

Keywords: Architectural geometry, gridshell, hexagonal mesh, free-form surface, rationalization, pavilion

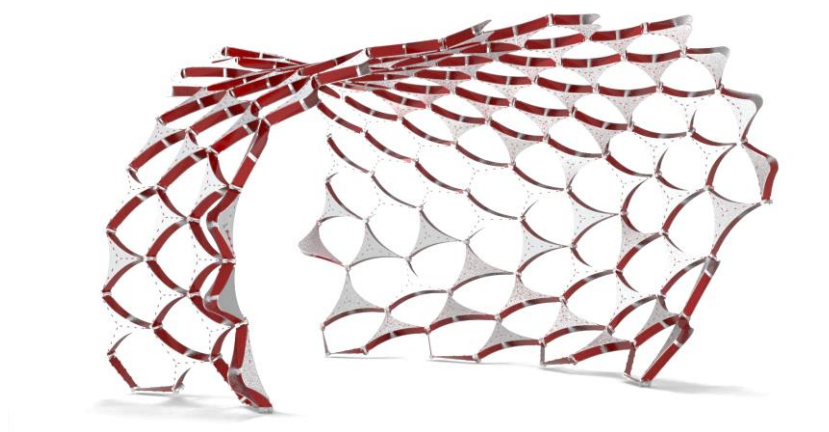

Figure 1: Rendering of the X-Mesh pavilion

1. Introduction

Free-form architectural structural envelopes have become increasingly popular in the past decades. The cost of these projects is usually strongly impacted by the fabrication of the nodes, which often need to be all unique. The connection between beams and panels is also problematic, as the kink angles between adjacent panels often vary significantly.

Two main geometrical strategies have been studied and used to simplify node fabrications in order to reduce their cost. The first one is to use a geometry that allows for torsion-free nodes. In such nodes, all the median planes of the incoming beams meet on a common axis. For example, the nodes shown in Figure 2 are torsion-free. This property can be achieved by having all beams in a vertical plane or by using circular or conical meshes ([1], [2]). Planar hexagonal meshes also have torsion-free nodes, but the hexagons are necessarily non-convex (shaped like a bow-tie) in anti-elastic surfaces [3].

The second one is node repetition. As detailed by Eike Schling in [4], node repetition can be achieved by two means. The first one is to have the exact same geometry for each node, or for some groups of nodes. For example, this can be achieved with meshes of revolution, or with isogonal molding surfaces [5]. The second one is to use construction tolerances or adjustable nodes to allow one or more degrees of angle variation with a same physical connector. This last option was for example used in the Neckarsulm swimming pool dome [6].

Regarding the beam-panel connection, the variation of the kink angle between the panel and the top surface of the beams renders impossible to make the connection structural, and thus to use the cladding system as a structural element. Furthermore, complex joining systems are needed if the kink angle is too high. Solutions were studied in [7].

In this article, we propose a new geometric configuration, based on a hexagonal mesh, that solves both of these problems. In section 2, we detail this geometric structure, discuss its potential applications, and prove its existence. A generation method is then presented in section 3. Finally, in section 4, we present how this process has been applied to design and rationalize the X-Mesh pavilion.

2. A new torsion free geometrical configuration

The proposed geometrical configuration is a continuation of the work presented in [7], and is shown in Figure 2. The configuration is based on a hexagonal mesh with non-planar faces. Each of its nodes is assigned with an axis. The configuration satisfies the following properties:

- (a) The axes of two adjacent nodes are coplanar and their common plane corresponds to the median plane of the beam;
- (b) Every other node is flat: the incoming edges are coplanar. These nodes are referred to as 2D nodes, the other nodes are named 3D nodes;
- (c) For 2D nodes, the axis is perpendicular to the plane of the node;
- (d) For 3D nodes, the beam planes intersect at 120° .

This mesh can be used to design a hexagonal gridshell covered by tri-folded hexagonal panels. In that case, the properties that we just described can significantly simplify the fabrication, in particular with respect to the connections between the structural elements, as shown in Figure 3. Firstly, the contact between panels and beams top surface is perfect and the angle between beam webs and panels is 90° . Thanks to these properties, standard low-cost connections can be used to structurally connect beams to panels. Secondly each node is torsion-free: medial axes of beams meet on a common axis. As a result, structural depth can easily be given to the grid. Thirdly, one half of the nodes are planar, and for the other half, beam planes intersect at 120° , thus allowing a standardization of all beam connections.

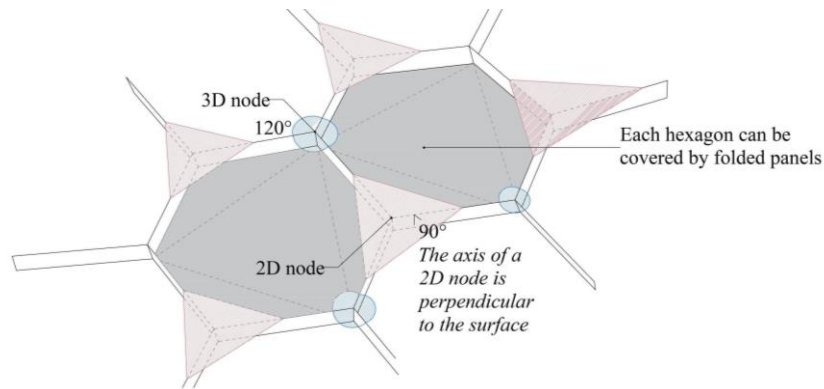

Figure 2: Geometrical configuration

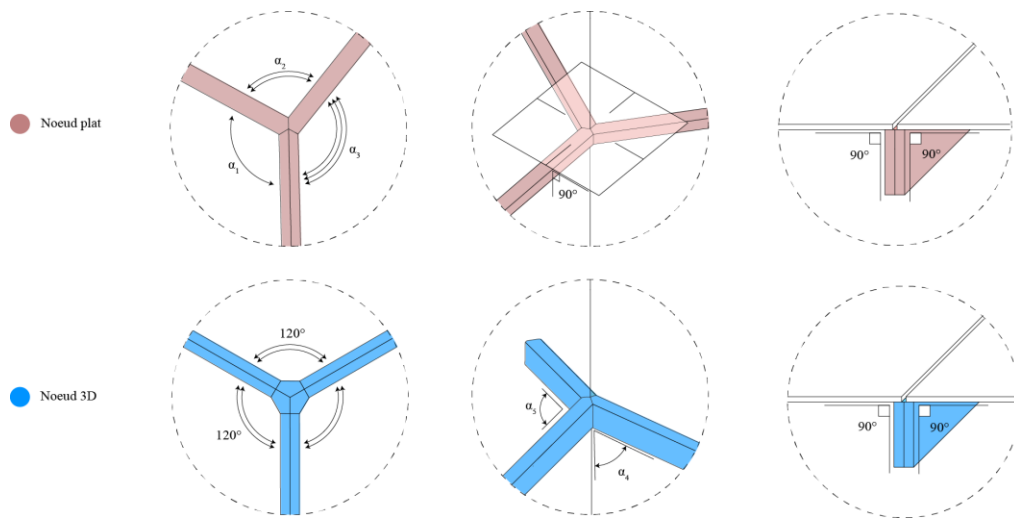

Figure 3: Geometry of connections structural elements

The thus formed gridshell is a clad honeycomb structure. We note that Jiang *et al.* [8] proposed a method to design this type of structure without torsion on an arbitrary target surface. However, they do not constrain the node axes to be normal to the surface. This is major difference with our configuration, which is therefore much more constrained geometrically.

The proposed properties (a), (b) and (c) form a new type of geometrical structure, based on a mesh in which face normals and vertex normals are coplanar. The proposed application is based on a hexagonal pattern, but many other types of patterns and structural applications are possible [7]. For clarity, we propose to name this type of mesh a *Caravel mesh*, an acronym standing for *meshes with CoplanAR face and VERtex normaLs*.

3. Smooth surface approximation

In this part, we prove by construction the existence of the geometric structure described in the previous sections in the asymptotic case, i.e. in the case where a mesh approximates a surface with smaller and smaller face size. In this case, properties can then be described in the setting of smooth differential geometry. We will show that it is asymptotically possible to construct our geometry from a planar hexagonal mesh approximating a smooth surface S without umbilics and such that one family of hexagon edges is aligned with curvature directions.

Let us start by introducing a classical local approximation model of a surface. A surface S can be locally approximated at any point P at the second order by a paraboloid. This paraboloid is elliptic if the Gaussian

curvature K is positive (i.e. the surface is synclastic), cylindrical if $K=0$, and hyperbolic if $K<0$ (i.e. the surface is anticlastic). The equation of this paraboloid is, in the tangent plane at P :

$$z = \frac{1}{2}(k_1x^2 + k_2y^2)$$

Where k_1 and k_2 are the principal curvatures. The unit normal of the paraboloid at a point (x,y,z) neighboring P is given by :

$$\vec{n}(x,y) = n(x,y)(-k_1x; -k_2y; 1)$$

The application $(x,y) \mapsto \vec{n}(x,y)$ is referred to as the surface Gauss map. The value of the real factor $n(x,y)$ will not be important here. Considering a neighborhood such that $|x| \ll 1/k_1$ and $|y| \ll 1/k_2$, $\vec{n}(x,y)$ belongs at the first order to a horizontal plane, and is then an orthotropic dilatation in the directions x and y . The ratios of the dilatation in the x and y directions are k_1 and k_2 , up to an homothety (the scaling of the Gauss map is not important in our construction).

After this preliminary considerations, we are now going to construct a mesh and its vertex normals satisfying the properties described in the previous sections. We will use a capital N to describe the mesh normals, as they often differ from the surface normals n .

Let us first consider a series of planar hexagonal meshes with decreasing faces sizes approximating S , and with one family of edges aligned with a principal curvature direction. As mesh size tends towards zero, each hexagon tends to have central symmetry and to be inscribed in a homothetic copy of the Dupin indicatrix, as explained in [9] – the Dupin indicatrix being the conic resulting from the intersection between the paraboloid and the plane $z=1$. As shown in Figure 3 (left), the surface Gauss map of the Dupin indicatrix is also a conic, with equation $\frac{x^2}{k_1} + \frac{y^2}{k_2} = 1$ (up to a homothety).

Let us pick three vertices on an hexagon $ABCDEF$ to form a triangle ACE . We build the Fermat center P of ACE , i.e. the point such that $(\vec{PA}, \vec{PC}) = (\vec{PC}, \vec{PE}) = (\vec{PE}, \vec{PA}) = 120^\circ$. P will be a flat node of the mesh, and A, C and E will be 3D nodes. This construction yields properties (b) and (d).

In order to fulfill property (b), the mesh normal at P , N_P , must be the normal of triangle ACE . This normal is, in the space of normals, the center of the Gauss map of the Dupin indicatrix. As we want no torsion along PA , PB and PC (property (a)), the mesh normal at A , N_A , must lie on a line l_A parallel to (AP) passing through N_P . In the general case, this line does not include the surface Gauss map at A , therefore $N_A \neq n_a$ (this is a second order difference, as the normals are equal at the limit).

Now, considering adjacent hexagons Figure 3 (middle), we observe that the lines previously built intersect on one point with the same lines from the neighboring hexagons if and only if edges AB and DE are aligned with a principal direction (i.e. parallel to an axis of the conic). These intersections points N_{Q1}, N_{Q2}, \dots are the normals of the 3D nodes.

The hexagonal network (in red) along with the attached normals described by the hexagonal mesh on the Gauss map (also in red) verify all the geometrical properties described in the previous sections.

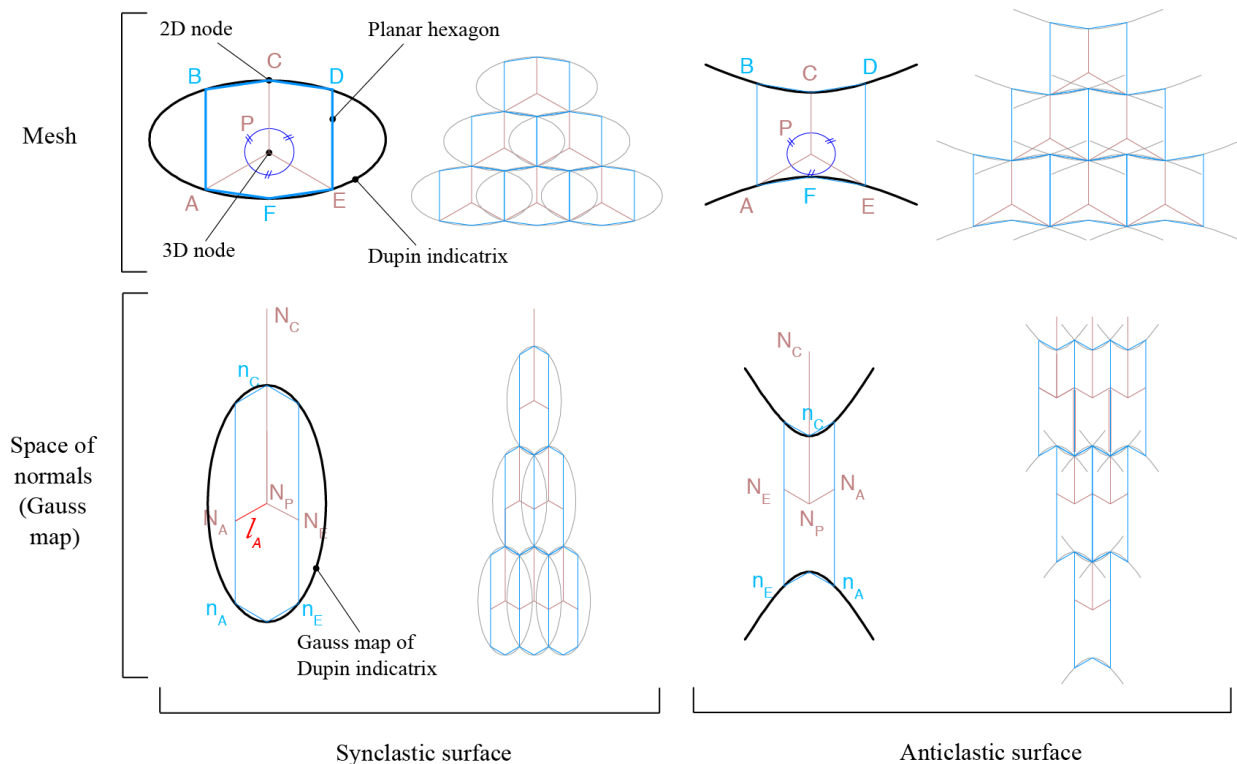

Figure 3: Asymptotic construction

3. Generation method

We now give a method to generate the geometrical configuration described in section 2. In a first step, we compute an initial mesh close to this configuration. In a second step, we optimize node position and normals orientation such that properties (a) to (d) are satisfied within given tolerances.

The initial mesh is constituted of hexagons where all edges are aligned with principal curvature directions. Each hexagon has two 180° corners, so the mesh looks like a brick wall. Wang *et al.* showed in [9] that this type of mesh can converge efficiently towards a planar-hexagons mesh. Since we showed in section 2 that our geometric configuration can be built on a planar-hexagons mesh, this initialization is also effective for our geometry.

The mesh resulting from the initialization is then used as the input of a non-linear optimization defined within the framework of RhinocerosTM's plugin Kangaroo2. The optimization problem is made of multiple geometrical criteria. Each criterion is expressed as a projection. Every node is assigned with a normal. A first criterion forces every node of valence three to be torsion-free (property (a)), by requiring the normals of the three neighboring nodes to be such that the median planes of the beams coming to the node meet on a common line corresponding to its normal. A second criterion makes the 2D nodes and their respective neighboring nodes coplanar (property (b)). A third one constraints the normals of the 2D nodes to be respectively aligned with the normals of the planes defined by their three neighboring nodes (property (c)). Finally, a fourth one forces 3D nodes to be, when projected on the triangles defined by their three neighboring nodes, the Fermat points of these triangles (property (d)). Complementary criteria are also set for smoothing purposes, such as proximity to the target surface, and to treat the boundaries.

This optimization problem is highly non-linear and non-convex. Hence, there is no theoretical guarantee that the mesh obtained after iterations of the optimization algorithm perfectly meet all the criteria or reach a global minimum of the problem. However, empirically, the resulting mesh tends to satisfy all the

geometrical properties within very low tolerances as shown in Figure 4. Thus, this two-step method allows in practice to generate a geometrical configuration as described in section 2 within acceptable tolerances.

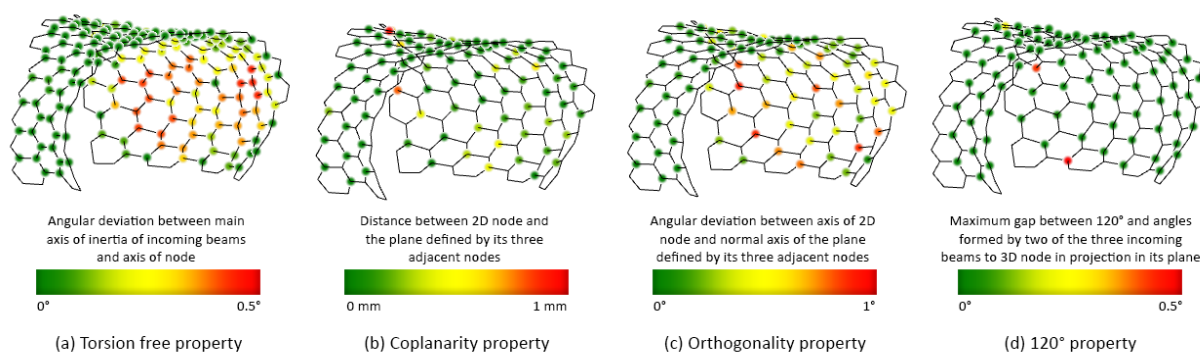

Figure 4: Convergence of algorithm regarding properties (a) to (d)

4. The X-Mesh pavilion

In order to demonstrate the innovation and the adaptability of the workflow hereby presented, it was applied to the design and realization of a pavilion for the IASS 2019 Pavilion contest.

4.1. Design

The shape of the pavilion is a doubly curved envelope, of which transversal sections are horseshoe arches. The shape has both synclastic and anticlastic portions, and demonstrates the ability of our method to generate structures on a broad class of forms. The pavilion is high enough to walk under, so it is possible to enjoy the view from the inside as well as from the outside.

The starting point of the design is a surface, which was discretized by a hexagonal mesh aligned with curvature lines. There are two ways to align a hexagonal mesh with curvature directions. The alignment with the horizontal curvature lines is chosen in order to create the graphic impression of an ascending movement, as the triangular panels are pointing upwards diagonally.

The concept of this pavilion focuses on highlighting the geometrical properties through the architectural treatment of the elements, especially the connections. The conception of each type of node is entirely based on the geometrical rationalization that simplifies its fabrication. We took advantage of each geometrical strategy to define the technology of the pavilion.

The pavilion is made of laser-cut aluminum plates. There are two main components: beams and cladding panels, as shown in Figure 6.

4.2. Structure

The torsion free nodes allowed us to conceive the main hexagonal grid as a beam structure. Indeed, since adjacent node axes are coplanar, their common plane defines the median planes of beams. This allowed us to build all of our elements out of sheet materials.

We took advantage of the node repetition to design two standards types of connections, one for each type of geometrical node (2D and 3D). These nodes are showed in Figure 6. 2D nodes offered us the possibility to create a structural connection through the common plane of the three incoming beams. This connection was realized by two aluminum panels on the superior and inferior edge of the three beams.

Structurally, the height of the beams can be adjusted to have sufficient vertical inertia. The horizontal inertia is guaranteed by the cladding panels. Panels are fixed to the edges of the three beams thanks to

locking tabs in which the carved panels are pushed into. As beams are orthogonal to panels, all the cuts are orthogonal to the sheet planes, and can thus be realized by 2D laser cutting.

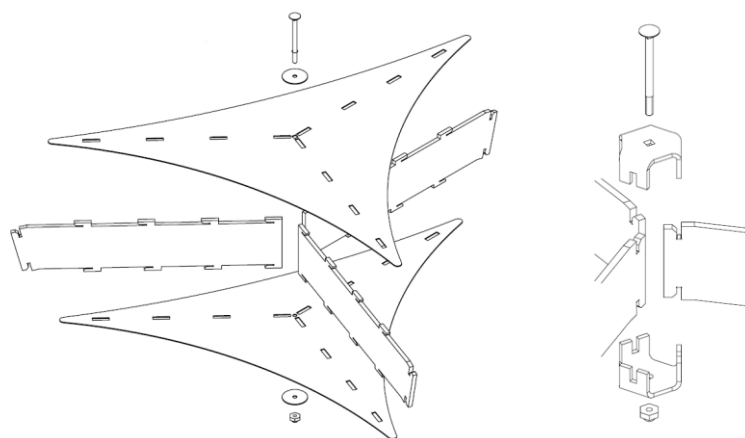

Figure 6: Technological solution for the 2D and 3D nodes

The technological treatment of the 3D nodes is based on the existence of an axis assigned to each node and on the fact that beam planes always intersect at 120° . For 3D nodes, a hinged connection is built from two pieces, cut out from thicker aluminum sheets and swagged in a stamping press. These formed parts are all identical and guaranty the 120° angle between each beam plane of the 3D node. They are maintained in place thanks to a single screw, materializing the direction of the normal axis of the node.

The two types of junctions are adapted on the free edges of the pavilion; thus it is unnecessary to develop an entirely different solution for the nodes on the boundary. Only two beams are joined on 3D nodes on naked edges, so in order to keep the same technological solution, we add a short stub that closes the node. 2D nodes with only two beams can work the same way on naked edges than on interior edges, as long as the panel is designed accordingly. This degree of freedom offers the opportunity to adapt the general design of the edge.

4.3. Mesh alignment with ground level

For aesthetic and fabrication reasons, it was desirable to align the mesh with the the ground. Since the mesh follows curvature directions, we modified the target surface so that its bottom boundaries (verifying $z=0$) are curvature lines. By the Joachimsthal theorem, this property is achieved if the surface has a constant slope along the lines $z=0$. As our target surface is a B-spline, the slope at the ground boundary is given by the bottom two rows of control points. We therefore optimized the position of these control points so that the slope of the surface is constant at the ground level.

4.4. Structural check

To ensure the safety and structural behavior of the pavilion, we implemented a finite element model of the structure and verified its behaviour under dead load and accidental load. Stress concentrations around the cuts were verified by local models using 2D plate elements.

5. Conclusion

In this article, we demonstrated the potential of the so-called Caravel meshes for structural applications by designing a full scale pavilion which is to be exhibited at the 60th IASS Symposium in October 2019. The geometry is further rationalized so that only two types of nodes are used throughout the whole structure.

Acknowledgements

Pavilion costs were covered by the I-Site Impulsion grant “Games”. We thank Viry for providing steel cladding panels, and ENSA Paris Malaquais for its financial support. The first author is financially supported by LABEX MMCD (<http://mmcd.univ-paris-est.fr/>). We would like to thank Eike Schling and Daniel Piker for fruitful discussions.

References

- [1] Y. Liu, H. Pottmann, J. Wallner, Y.-L. Yang, and W. Wang, “Geometric modeling with conical meshes and developable surfaces,” *ACM Trans. Graph.*, vol. 25, no. 3, p. 681, 2006.
- [2] H. Pottmann and J. Wallner, “The focal geometry of circular and conical meshes,” *Adv. Comput. Math.*, vol. 29, no. 3, pp. 249–268, 2008.
- [3] W. Wang, “Hexagonal Meshes with Planar Faces,” no. January, 2008.
- [4] E. Schling, “Repetitive Structures,” TUM, 2018.
- [5] R. Mesnil, C. Douthe, O. Baverel, B. Léger, and J. F. Caron, “Isogonal moulding surfaces: A family of shapes for high node congruence in free-form structures,” *Autom. Constr.*, vol. 59, pp. 38–47, 2015.
- [6] Schalich Bergermann und Partners, “Freizeitbad aquatoll neckarsulm.” [Online]. Available: <https://www.sbp.de/projekt/freizeitbad-aquatoll-neckarsulm/>. [Accessed: 13-May-2019].
- [7] X. Tellier, O. Baverel, C. Douthe, and L. Hauswirth, “Gridshells without kink angle between beams and cladding panels,” *Proc. IASS Symp. 2018 Creat. Struct. Des. Boston, USA*, 2018.
- [8] C. Jiang, J. Wang, J. Wallner, and H. Pottmann, “Freeform honeycomb structures,” in *Computer Graphics Forum*, 2014, vol. 33, no. 5, pp. 185–194.
- [9] W. Wang and Y. Liu, “A Note on Planar Hexagonal Meshes,” in *Nonlinear Computational Geometry*, Springer,., 2009, pp. 221–233.